

6062A

SYNTHESIZED RF SIGNAL GENERATOR

Instruction Manual

P/N 794842

MAY 1987 Rev.1, 3/88

©1988, John Fluke Mfg. Co., Inc. All rights reserved. Litho in U.S.A.



WARRANTY

Notwithstanding any provision of any agreement the following warranty is exclusive:

The JOHN FLUKE MFG. CO., INC., warrants each instrument it manufactures to be free from defects in material and workmanship under normal use and service for the period of 1-year from date of purchase. This warranty extends only to the original purchaser. This warranty shall not apply to fuses, disposable batteries (rechargeable type batteries are warranted for 90-days), or any product or parts which have been subject to misuse, neglect, accident, or abnormal conditions of operations.

In the event of failure of a product covered by this warranty, John Fluke Mfg. Co., Inc., will repair and calibrate an instrument returned to an authorized Service Facility within 1 year of the original purchase; provided the warrantor's examination discloses to its satisfaction that the product was defective. The warrantor may, at its option, replace the product in lieu of repair. With regard to any instrument returned within 1 year of the original purchase, said repairs or replacement will be made without charge. If the failure has been caused by misuse, neglect, accident, or abnormal conditions of operations, repairs will be billed at a nominal cost. In such case, an estimate will be submitted before work is started, if requested.

THE FOREGOING WARRANTY IS IN LIEU OF ALL OTHER WARRANTIES, EXPRESS OR IMPLIED, INCLUDING BUT NOT LIMITED TO ANY IMPLIED WARRANTY OF MERCHANTABILITY, FITNESS, OR ADEQUACY FOR ANY PARTICULAR PURPOSE OR USE. JOHN FLUKE MFG. CO., INC., SHALL NOT BE LIABLE FOR ANY SPECIAL, INCIDENTAL, OR CONSEQUENTIAL DAMAGES, WHETHER IN CONTRACT, TORT, OR OTHERWISE.

If any failure occurs, the following steps should be taken:

1. Notify the JOHN FLUKE MFG. CO., INC., or nearest Service facility, giving full details of the difficulty, and include the model number, type number, and serial number. On receipt of this information, service data, or shipping instructions will be forwarded to you.
2. On receipt of the shipping instructions, forward the instrument, transportation prepaid. Repairs will be made at the Service Facility and the instrument returned, transportation prepaid.

SHIPPING TO MANUFACTURER FOR REPAIR OR ADJUSTMENT

All shipments of JOHN FLUKE MFG. CO., INC., instruments should be made via United Parcel Service or "Best Way" prepaid. The instrument should be shipped in the original packing carton; or if it is not available, use any suitable container that is rigid and of adequate size. If a substitute container is used, the instrument should be wrapped in paper and surrounded with at least four inches of excelsior or similar shock-absorbing material.

CLAIM FOR DAMAGE IN SHIPMENT TO ORIGINAL PURCHASER

The instrument should be thoroughly inspected immediately upon original delivery to purchaser. All material in the container should be checked against the enclosed packing list. The manufacturer will not be responsible for shortages against the packing sheet unless notified immediately. If the instrument is damaged in any way, a claim should be filed with the carrier immediately. (To obtain a quotation to repair shipment damage, contact the nearest Fluke Technical Center.) Final claim and negotiations with the carrier must be completed by the customer.

The JOHN FLUKE MFG. CO., INC. will be happy to answer all applications or use questions, which will enhance your use of this instrument. Please address your requests or correspondence to: JOHN FLUKE MFG. CO., INC., P.O. BOX C9090, EVERETT, WASHINGTON 98206, ATTN: Sales Dept. For European Customers: Fluke (Holland) B.V., P.O. Box 5053, 5004 EB, Tilburg, The Netherlands.

*For European customers, Air Freight prepaid.

John Fluke Mfg. Co., Inc., P.O. Box C9090, Everett, Washington 98206

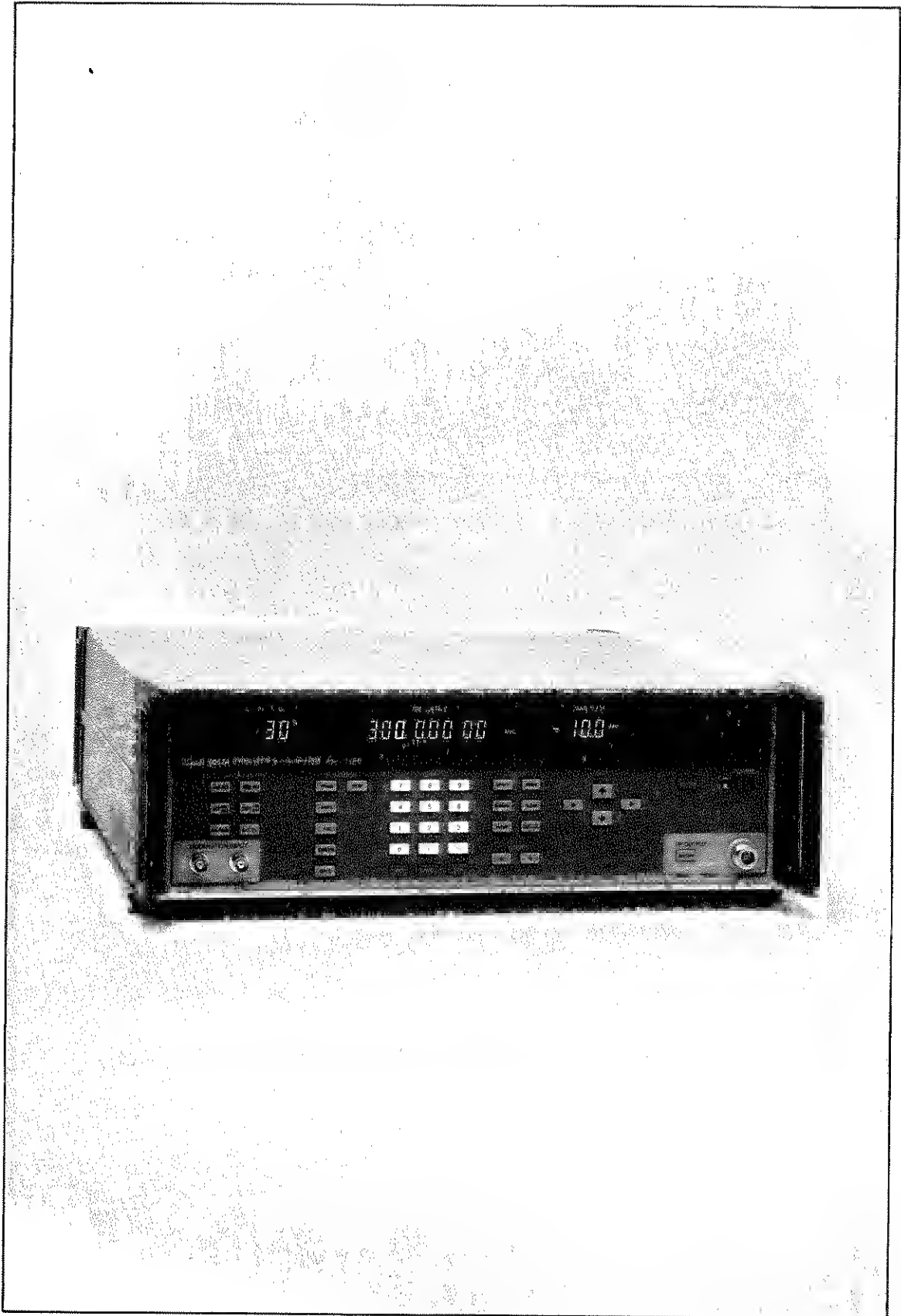

6062A Synthesized RF Signal Generator

Section 1

Introduction and Specifications

1-1. INTRODUCTION

The 6062A Synthesized RF Signal Generator (referred to as the Generator or instrument) is a fully-programmable, precision, synthesized signal generator. The Generator is designed for applications that require good modulation, frequency accuracy, and output level performance with moderate spectral purity. It is well suited for testing a wide variety of RF components and systems including filters, amplifiers, mixers, and radios, particularly on-channel radio testing.

1-2. UNPACKING THE GENERATOR

The shipping container should include a 6062A Synthesized RF Signal Generator, an Operator Information Card, a Getting Started Manual, an Instruction Manual, a line power cord and two BNC dust caps. Any accessories ordered for the Generator are shipped in a separate container.

Section 2, Installation and Operation, gives instructions on inspecting the new Generator and explains what to do if the instrument arrives with shipping damage. Reshipment information is also included.

1-3. SAFETY

This instruction manual contains information, warnings, and cautions that should be followed to ensure safe operation and to maintain the Generator in a safe condition.

The Generator is designed primarily for indoor use, and it may be operated in temperatures from 0 to 50°C without degradation of its safety.

WARNING

TO AVOID ELECTRIC SHOCK, USE A POWER CORD THAT HAS A THREE-PRONG PLUG. IF A PROPER POWER CORD IS NOT USED, THE 6062A CASE CAN DEVELOP AN ELECTRICAL POTENTIAL ABOVE EARTH GROUND.

CAUTION

To avoid damage to the 6062A, check that the rear panel line voltage selection card and fuse are correct for the line voltage in your area. The correct line voltage and fuse combinations are:

LINE VOLTAGE	FUSE
100/120V ac, $\pm 10\%$, 47 to 63 Hz	1.5 amp
220/240V ac, $\pm 10\%$, 47 to 63 Hz	.75 amp

1-4. OPERATOR INFORMATION CARD

The Operator Information Card has an adhesive backing so it can be affixed to the top of the Generator in bench applications or to the operator console in remote applications. A copy of the card is located at the end of Section 8 of this manual as a convenient reference or for duplication.

1-5. GENERATOR DESCRIPTION

Fundamental features of the Generator are as follows:

- 0.10- to 1050-MHz frequency range in 10-Hz steps
- 1050- to 2100-MHz frequency range in 20-Hz steps
- +16 to -137-dBm level range in 0.1-dB steps from 0.10 to 1050 MHz
- +13 to -137-dBm level range in 0.1-dB steps from 1050 to 2100 MHz
- AM, FM, ϕ M, and Pulse, internal or external
- Internal 400- and 1000-Hz modulation oscillator
- Relative frequency and amplitude
- Volts/dBm conversion
- Store/recall memory
- Instrument (or controller) prompted software compensation
- Master/slave for frequency, amplitude, and modulation functions (IEEE-488 Interface controlled.)
- Fluorescent display
- 5¼-inches high, rack mountable

1-6. Controller Functions

The Generator's microprocessor controls all operator interface functions, performs background operations such as status checks, and updates (strokes) the front panel displays. Whether the operator is using local control with the front panel, or remote control with the IEEE-488 Interface, the microprocessor provides self test and diagnostic capability. Economical instrument performance is achieved by using software compensation and accuracy-enhancement circuitry.

1-7. LOCAL CONTROL

The value of the basic output parameters of the Generator (i.e., amplitude, frequency, or modulation) can be controlled in three ways:

- Direct numeric entry
- Incrementing or decrementing the bright digit
- Step-up or step-down entry where the operator can program the step size via the front panel

Other controls provide selection of the modulation control, internal/external frequency reference, instrument status, and special function modes. Refer to Tables 2-1 and 2-2 for a more complete discussion.

1-8. DISPLAY FIELD

The programmed values of modulation, frequency, and amplitude are displayed in the three display fields. In addition, when the operator presses the [STATUS] key, uncal and reject entry codes are displayed. The display also prompts the operator during the software compensation procedures.

1-9. REMOTE-CONTROL PROGRAMMING

The IEEE-488 Interface allows the Generator to be remotely controlled with any IEEE-488 bus controller. The operator can also use the instrument on the IEEE-488 bus without a controller in a listen-only or talk-only mode by selecting the appropriate Generator rear panel IEEE-488 switch settings.

All instrument controls can be controlled remotely except the POWER ON/OFF and the rear panel REF INT/EXT switches. The IEEE-488 Interface provides additional commands not available with local control, such as data transfer and individual control of internal I/O control bits.

The IEEE-488 Interface allows two Generators to track amplitude, frequency, or modulation in a master/slave configuration when the operator uses the front panel step-up and step-down entries on one of the instruments. For instance, frequency tracking is convenient for tests involving mixers, and amplitude tracking is useful for two-tone intermodulation testing.

1-10. Frequency

The specified frequency range is 0.10 to 2100 MHz. The frequency is synthesized from a 10-MHz reference and provides an output resolution of 10 Hz from 0.10 to 1050 MHz, and 20 Hz from 1050 to 2100 MHz. The relative frequency mode allows the operator to program the frequency in relation to a center frequency or an offset frequency. This is convenient for testing filters and mixers. The output frequency stability and accuracy depends on the reference, whether that reference is internal or external.

1-11. Reference

The internal frequency reference is a 10-MHz ambient crystal oscillator. If Option -130 High Stability Reference or Option -132 Medium Stability Reference is installed, the internal oscillator is locked to the option oscillator.

With the REF INT/EXT switch set to EXT, the Generator can be operated from an external 1-, 2-, 2.5-, 5-, or 10-MHz, 0.3 to 4V peak-to-peak sine or square-wave reference applied to the REF IN connector. In either position of the REF INT/EXT switch, the selected reference is available as a 10-MHz signal at the rear panel 10 MHz OUT connector.

1-12. Amplitude

The Generator has two specified signal level ranges:

- +16 to -137 dBm (1.41V to 0.1 μ V) over a frequency range of 0.10 to 1050 MHz
- +13 to -137 dBm (1V to 0.033 μ V) over a frequency range of 1050 to 2100 MHz.

The programming limits are +17 and -147.4 dBm, which correspond to limits of 1.58V to 0.01 μ V. The level entry can be in dBm or volts, or it can be converted from one to the other. The

INTRODUCTION AND SPECIFICATIONS

relative amplitude mode allows the operator to account for cascaded gain or loss by displaying the level relative to the initial setting.

1-13. Modulation

The Generator has internal and external amplitude, frequency, phase, and pulse modulation capabilities. The internal modulation oscillator is selectable between 400 and 1000 Hz. AM depths of 0 to 99% are available in 1% steps. FM deviation ranges of 1, 10, 100, and 400 kHz are available in steps of 1, 10, 100 Hz, and 1 kHz, respectively. ϕ M deviation ranges of 0.10, 1.0, 10.0, and 40.0 radians (rad) are available in steps of 0.001, 0.01, 0.1, and 0.1 radians, respectively. The internal Pulse duty cycle is approximately 50%. External Pulse allows rates from dc up to 16 MHz, and duty cycles from 0 to 100%.

1-14. OPTIONS AND ACCESSORIES

The following options are available for the Generator:

- Option -130 High-Stability (Ovened) Reference
- Option -132 Medium-Stability Reference
- Option -651 Low-Rate FM (External only)
- Option -830 Rear Panel RF Output, MOD Input, and Pulse MOD Input

Section 6 provides more detailed information on the options.

The following accessories are included with each Generator:

DESCRIPTION	PART NUMBER	QUANTITY
Operator Information Card	797928	1
Getting Started Manual	794859	1
Instruction Manual	794842	1
Line Power Cord	284174	1
BNC Dust Cap	478982	2

The following accessories are available for the Generator:

DESCRIPTION	ACCESSORY NO.
Rack Mount Kit. Includes M05-205-600 (5¼-inch Rack Mount Ears) and M00-280-610 (24-inch Rack Slides)	Y6001
IEEE-488 Shielded Cable, 1 meter	Y8021
IEEE-488 Shielded Cable, 2 meters	Y8022
IEEE-488 Shielded Cable, 4 meters	Y8023
Coaxial Cable, 50 ohms, 3 feet, BNC (m) both ends	Y9111
Coaxial Cable, 50 ohms, 6 feet, BNC (m) both ends	Y9112

1-15. RECOMMENDED TEST EQUIPMENT

The test equipment recommended for the performance tests, calibration adjustments, and troubleshooting are listed in Table 4A-1. This equipment is assumed to be calibrated to the manufacturer's specifications. If the recommended test equipment is not available, equivalent test equipment can be substituted.

1-16. MNEMONICS

The mnemonics used in the schematics, block diagrams, wiring diagrams, truth tables, and the text are listed in Figure 8-1.

1-17. SIGNAL GENERATOR SPECIFICATIONS

Unless otherwise noted, the following performance is guaranteed over the specified environmental and ac power line conditions 20 minutes after turn-on. Table 1-1 lists the Generator specifications.

Table 1-1. 6062A Synthesized RF Signal Generator Specifications

Warranted performance, 20 minutes after power-on within operating temperature range.	
FREQUENCY (9 1/2-Digit Display)	
RANGE	0.1 to 2100.0 MHz in 4 bands; 0.1 to 244.99999 MHz, 245 to 511.99999 MHz, 512 to 1049.99999 MHz, 1050 to 2100.0 MHz.
RESOLUTION	10 Hz from 0.1 to 1050 MHz, 20 Hz from 1050 to 2100 MHz.
ACCURACY	Same as reference (See REFERENCE).
REFERENCE (Internal)	The unit operates on an internal free-air 10-MHz crystal oscillator with an ageing rate of $< \pm 0.5$ ppm/month and $< \pm 5$ ppm for 25°C , $\pm 25^{\circ}\text{C}$. Internal reference signal (10-MHz) available at rear connector, level > 0 dBm, terminated in 50-ohms.
REFERENCE (External)	Accepts 1-, 2-, 2.5-, 5-, or 10-MHz signal. Level of 0.3 to 4.0 Vpp into 50-ohms termination.
AMPLITUDE (3 1/2-Digit Display)	
RANGE (Indicated)	+16 (+16 peak with AM enabled) to -137 dBm, from 0.1 to 1049.99999 MHz. +13 (+13 peak with AM enabled) to -137 dBm, from 1050 to 2100 MHz. (Autoranging 6-dB step attenuator).
RESOLUTION	0.1 dB ($< 1\%$ or 1 nV in volts). Annunciators for dB, dBm, V, mV, uV, dB mV, and dB uV.
ACCURACY	± 1 dB from +16 to -127 dBm from 1 to 1049.99999 MHz. * ± 1.5 dB from +13 to -127 dBm from 1050 to 2100 MHz. ± 2.0 dB from +16 to -127 dBm from 0.1 to .99999 MHz.
	* ± 1.5 dB at temperatures other than $23^{\circ}\text{C} \pm 5^{\circ}\text{C}$

Table 1-1. 6062A Synthesized RF Signal Generator Specifications (cont)

SOURCE VSWR	<1.5:1 below +1 dBm, <2.0:1 elsewhere.
SPECTRAL PURITY (CW ONLY)	
SPURIOUS	<-60 dBc for offsets greater than 10 kHz and frequencies from 0.1 to 1049.99999 MHz. <-54 dBc for offsets greater than 10 kHz and frequencies from 1050 to 2100 MHz.
NOTE	
Fixed frequency spurs are <-60 dBc or <-140 dBm whichever is larger.	
NOTE	
dBc refers to decibels relative to the carrier frequency, or in this case, relative to the signal level.	
HARMONICS	<-30 dBc for levels \leq +13 dBm and frequencies \geq 1 MHz, <-25 dBc elsewhere.
SUBHARMONICS	<-50 dBc for output frequencies from 1050 to 2100 MHz.
RESIDUAL FM (rms in 0.3- to 3-kHz band)	<12 Hz for 0.1 to 244.99999 MHz, <6 Hz for 245 to 511.99999 MHz, <12 Hz for 512 to 1049.99999 MHz, <24 Hz for 1050 to 2100 MHz.
RESIDUAL FM (rms in 0.05- to 15-kHz band)	<18 Hz for 0.1 to 244.99999 MHz, <9 Hz for 245 to 511.99999 MHz, <18 Hz for 512 to 1049.99999 MHz, <36 Hz for 1050 to 2100 MHz.
RESIDUAL AM (in 0.05- to 15-kHz Band)	<-60 dBc.
AMPLITUDE MODULATION (2-Digit Display)	
DEPTH RANGE	0 to 99%.
RESOLUTION	1%.
ACCURACY	$\pm(2\% + 4\%$ of setting) to peak amplitude of +13 dBm for frequencies to 2100 MHz. $\pm(3\% + 5\%$ of setting) to peak amplitude of +13 dBm for frequencies of 0.1 to .99999 MHz.

Table 1-1. 6062A Synthesized RF Signal Generator Specifications (cont)

DISTORTION	<p><1.5% total harmonic distortion (THD) to 30% AM, <3% THD to 70% AM, <5% THD to 90% AM for frequencies of 1 to 1049.99999 MHz and peak amplitude < +13 dBm.</p> <p><3% THD to 70% AM, and <5% THD to 90% AM for frequencies of 1050 to 2100 MHz and peak amplitude < +13 dBm.</p> <p><3% THD to 30% AM, <5% THD to 70% AM, and <7% THD to 90% AM for frequencies of 0.1 to .99999 MHz and peak amplitude < +13 dBm.</p>		
BANDWIDTH (3 dB)	<p>20 Hz to 50 kHz. DC to 50 kHz by special function. (Note-- valid for RF frequency - Mod frequency \geq150 kHz)</p>		
INCIDENTAL FM	<p><0.3 fm for internal rates, 30% or less AM, and frequencies from 0.1 to 1049.99999 MHz. <0.6 fm for internal rates, 30% or less AM, and frequencies from 1050 to 2100 MHz.</p>		
FREQUENCY MODULATION (3-Digit Display)			
DEVIATION RANGES	<p>0 to 999 Hz, 1 to 9.99 kHz, 10 to 99.9 kHz, and 100 to 400 kHz.</p>		
MAXIMUM DEVIATION			
	Mod Rate	Max Dev	RF Frequency
	fm \geq .2 kHz	400 kHz	1050 to 2100 Mhz
		200 kHz	512 to 1049.99999 MHz
		100 kHz	245 to 511.99999 Mhz
		200 kHz	0.1 to 244.99999 Mhz
	fm <.2 kHz	Lower of above or:	
		2 fm fo	245 to 2100 MHz
		2 fm(fo+800)	0.1 to 244.99999 MHz
	Where: fm = mod frequency in kHz		
	fo = RF frequency in MHz Deviation is in kHz		
	Specs apply where: RF Frequency - Dev \geq 150 kHz RF Frequency - Mod Rate \geq 150 kHz		
RESOLUTION	3 digits.		
ACCURACY	\pm (7% + 10 Hz) for rates of 0.3 to 20 kHz. Does not include effects of Residual FM.		

INTRODUCTION AND SPECIFICATIONS

Table 1-1. 6062A Synthesized RF Signal Generator Specifications (cont)

DISTORTION	<1% THD for rates of 0.3 to 20 kHz. Does not include effects of Residual FM.
BANDWIDTH (3 dB).....	20 Hz to 100 kHz. (Note-- valid for RF Frequency - Mod Frequency \geq 150 kHz)
INCIDENTAL AM	<1% AM at 1 kHz rate, for the maximum deviation or 50 kHz, whichever is less. Valid for RF Frequency \geq 1 MHz.
PHASE MODULATION (3 digit display)	
DEVIATION RANGES	0 to .099 rad, .100 to .999 rad, 1.00 to 9.99 rad, and 10.0 to 40.0 rad.
MAXIMUM DEVIATION	20 rad from 0.1 to 244.99999 MHz. 10 rad from 245 to 511.99999 MHz. 20 rad from 512 to 1049.99999 MHz. 40 rad from 1050 to 2100 MHz.
RESOLUTION	3 digits
ACCURACY	\pm (7% + .01 rad) at 1 kHz rate. Does not include effects of Residual FM.
DISTORTION	<1% THD for 1 kHz rate. Does not include effects of Residual FM.
BANDWIDTH (3 dB)	20 Hz to 10 kHz. (Note-- valid for RF Frequency - Mod Frequency \geq 150 kHz)
INCIDENTAL AM	<1% AM at 1 kHz rate.
PULSE MODULATION (RF Frequencies from 10 to 2100 MHz)	
ON/OFF RATIO	80 dB minimum
RISE & FALL TIMES	<15 nsec
LEVEL ERROR.....	for pulse widths \geq 50 nsec, power in the pulse within \pm 0.5 dB of measured CW level.
DUTY CYCLE (ext mod).....	0-100%
REP RATE (ext mod).....	DC-16 MHz
INTERNAL MODULATION	internal rates, approx 50% duty cycle.
EXTERNAL PULSE MODULATION	The pulse input is TTL compatible and 50 ohm terminated with an internal active pull-up. It can be modeled as 1.2 V in series with 50 ohms at the pulse modulation input connector. The instrument senses input terminal voltage and turns the RF off when the terminal voltage drops below $1 \pm$ 0.1 V. Max allowable applied voltage, \pm 10V.
PULSE MODULATION (RF Frequencies <10 MHz)	
RISE & FALL TIMES.....	\leq 2 X period of RF Frequency.

Table 1-1. 6062A Synthesized RF Signal Generator Specifications (cont)

LEVEL ERROR.....	for pulse widths ≥ 10 X period of RF Frequency, power in the pulse will be within ± 0.5 dB of the measured CW level.
Other specifications are the same as for the 10 to 2100 MHz range.	
NON-VOLATILE MEMORY	
50 instrument states are retained for typically 2 years, even with the power mains disconnected.	
REVERSE POWER PROTECTION	
PROTECTION LEVEL	up to 25 watts from a 50 ohm source. up to 25 VDC. Instrument output is AC coupled.
TRIP/RESET	Flashing RF OFF annunciator indicates a tripped condition. Pushing RF ON/OFF button will reset instrument. Protection is provided when instrument is off.
IEEE-488	
INTERFACE FUNCTIONS	SH1, AH1, T5, TE0, L3, LE0, SR1, RL1, PPO, DC1, DT1, CO, and E1.
MODULATION SOURCE	
INTERNAL	0.4 or 1 kHz, $\pm 3\%$ for 20 to 30°C; add $\pm 0.1\%/^{\circ}\text{C}$ outside this range.
EXTERNAL	$\pm 5\text{V}$ max.; 1V peak provides indicated modulation index. Nominal input impedance is 600 ohms.
MODES	Any combination of AM and FM or $\emptyset\text{M}$, internal or external, may be used. If external AM and FM or $\emptyset\text{M}$ are enabled, the modulation input Z will drop to approximately 560 ohms. Pulse modulation is completely independent and can be used in conjunction with any other form(s) of modulation.
GENERAL	
TEMPERATURE	
Operating	0 to 50°C (32 to 122°F).
Non-Operating	-40 to 75°C (-40 to 167°F).
HUMIDITY RANGE	
Operating	95% to 30°C, 75% to 40°C, 45% to 50°C.
ALTITUDE	
Operating	Up to 10,000 ft.
VIBRATION	
Non-Operating	5 to 15 Hz at 0.06 inch, 15 to 25 Hz at 0.04 inch, and 25 to 55 Hz at 0.02 inch, double amplitude (DA).

Table 1-1. 6062A Synthesized RF Signal Generator Specifications (cont)

SHOCK			
Non-Operating	Bench handling per MIL T 28800C Class 5, Style E.		
ELECTROMAGNETIC			
COMPATIBILITY	The radiated emissions induce <3 uV (<1 uV of the Generator's output signal) into a 1-inch diameter, 2-turn loop, 1-inch from any surface as measured into a 50-ohm receiver.		
Also complies with the following standards:			
CE03 of MIL-STD-461B (Power and interconnecting leads), 0.015 to 50 MHz.			
RE02 of MIL-STD-461B (14 kHz to 10 GHz).			
FCC Part 15 (j), class A.			
CISPR 11.			
SIZE	Width	Height	Depth
	43 cm	13.3 cm	50.8 cm
	17 in	5.25 in	20 in
POWER	100, 120, 220, 240V ac $\pm 10\%$, 47 to 63 Hz, <180 VA (<15 VA, with Option -130 installed, and the Generator turned off (standby)).		
WEIGHT	<15.7 kg (35 lbs).		
OPTION -130 HIGH-STABILITY REFERENCE			
AGING RATE	< 5×10^{-10} /day, after 21 days continuous operation.		
TEMPERATURE STABILITY	< $2 \times 10^{-10}/^{\circ}\text{C}$ (Oven remains powered in standby).		
OPTION -132 MEDIUM-STABILITY REFERENCE			
AGING RATE	< 1×10^{-7} /month after 5 days continuous operation.		
TEMPERATURE STABILITY	< $1 \times 10^{-7}/^{\circ}\text{C}$ (0 to 50 $^{\circ}\text{C}$) (no powered standby).		
OPTION -651 LOW-RATE EXTERNAL FM			
MAXIMUM DEVIATION	9.99 kHz.		
DROOP	<15% on a 10-Hz square wave.		
BANDWIDTH (3dB)	0.5 Hz to 100 kHz (typical).		
MAX DC INPUT	± 10 mV.		
INCIDENTAL AM	<1% AM at 1-kHz rate and deviation <10 kHz.		

Table 1-1. 6062A Synthesized RF Signal Generator Specifications (cont)

SUPPLEMENTAL CHARACTERISTICS

The following characteristics are provided to assist in the application of the Generator and to describe the typical performance that can be expected.

- FREQUENCY SWITCHING SPEED <100 ms to be within 100 Hz.
- AMPLITUDE SWITCHING SPEED <100 ms to be within 0.1 dB.
- AMPLITUDE RANGE Programmable from +17 to -147.4 dBm. Fixed-range, selected by special function, allows for more than 12 dB of vernier without switching the attenuator.
- AMPLITUDE ACCURACY..... ±2.0 dB from -127.1 to -137 dBm from 0.1 to 2100 MHz.
- NOISE (at 20-kHz offset) <-116 dBc/Hz from 0.10 to 244.99999 MHz.
<-122 dBc/Hz from 245 to 511.99999 MHz.
<-116 dBc/Hz from 512 to 1049.99999 MHz.
<-110 dBc/Hz from 1050 to 2100 MHz.

RESIDUAL FM (typical)

Freq Range	.3 - 3 kHz	.05 - 15 kHz	CCIT
0.1 - 244.99999 MHz	8 Hz	12 Hz	7 Hz
245 - 511.99999 MHz	4 Hz	6 Hz	3.5 Hz
512 - 1049.99999 MHz	8 Hz	12 Hz	7 Hz
1050 - 2100 MHz	16 Hz	24 Hz	14 Hz

EXTERNAL MODULATION Annunciators indicate when a 1V peak signal is applied, ±2%, over a 0.02- to 100-kHz band.

IEEE All controls except the power switch and the internal/external reference switch are remotely programmable via IEEE-488 Interface (Std 488-1978). All status including the option complement are available remotely. The Store/Recall memory data may be transferred via an external controller. In talk-only, the appropriate commands are generated when the front panel step-up and step-down entries are made to control another 6062A, 6060A, 6060B, 6070A, or 6071A. (6070/71A only have FREQUENCY STEP.)

FREQUENCY DRIFT <1 ppm/hr after 1 hour warmup at constant ambient temperature using internal free-air crystal.

PULSE MODULATION

PULSE DELAY..... OFF/ON 80 nsec typ
ON/OFF 65 nsec typ



Section 2

Installation and Operation

2-1. INTRODUCTION

This section describes how to install and operate the Generator. This section contains information for an initial inspection, setting up the instrument, general operating information, and local and remote operation.

2-2. INITIAL INSPECTION

The Generator is shipped in a special protective container that should prevent damage during shipment. Check the shipping order against the contents of the container, and report any damage or short shipment to the place of purchase or the nearest Fluke Technical Service Center. Instructions for inspection and claims are included on the shipping container.

If reshipment of the Generator is necessary, please use the original shipping container. If the original container is not available, use a container that provides adequate protection during shipment. It is recommended that the Generator be protected by at least three inches of shock-absorbing material on all sides of the container. Do not use loose fill to pad the shipping container. Loose fill allows the Generator to settle to one corner of the shipping container, which could result in the Generator being damaged during shipment.

2-3. SETTING UP THE GENERATOR

The following paragraphs describe how to set up the Generator for operation. This information includes: line power requirements, line voltage selection procedures, fuse replacement procedures, and rack mounting instructions.

2-4. Line Power Requirements

The Generator uses a line voltage of 100 or 120V ac rms ($\pm 10\%$) with a 1.5A fuse; or 220V or 240V ac ($\pm 10\%$) with a 0.75A fuse. The line frequency must be between 48 to 63 Hz. The power consumption of the instrument is <180 VA with a full option complement.

2-5. Line Voltage and Fuse Selection

CAUTION

Verify that the intended line power source matches the line voltage setting of the Generator before plugging in the line power cord.

Refer to Figure 2-1 to set the line voltage of the Generator to match the available source. Figure 2-1 also shows how to replace the line fuse of the Generator. The correct fuse value for each of the four line voltages is listed on a plate attached to the rear panel of the Generator.

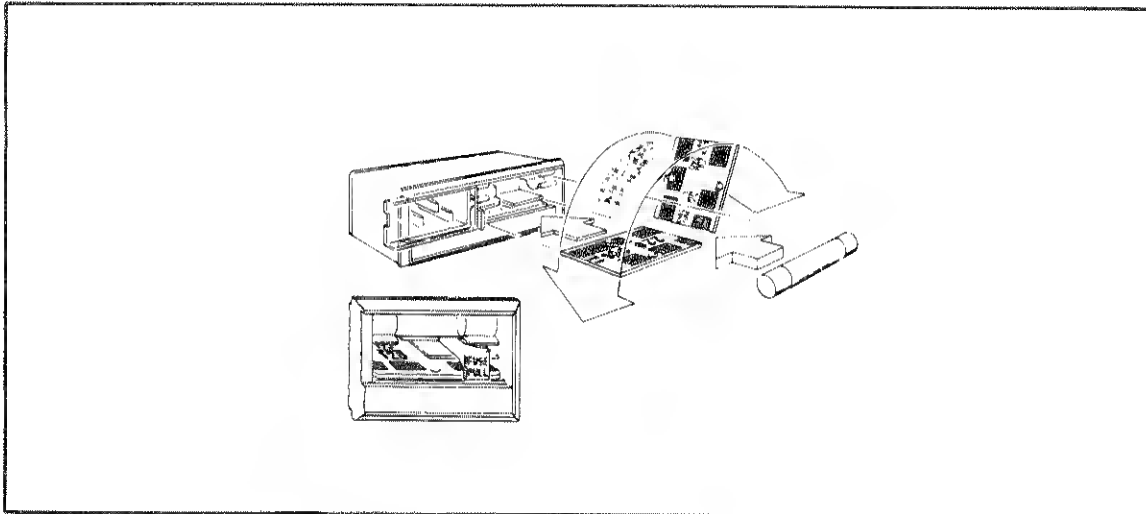

Figure 2-1. Fuse/Filter/Line Voltage Selection Assembly

2-6. IEEE-488 Address

The IEEE-488 address can be selected using the switches located next to the IEEE-488 connector on the rear panel. Talk-only and listen-only modes can also be selected on this switch.

NOTE

To meet the specified radiated emissions, the IEEE-488 connector must be terminated with a shielded IEEE-488 cable, such as a Fluke Y8021.

2-7. RACK OR BENCH MOUNTING THE GENERATOR

CAUTION

Allow at least 3 inches of clearance behind and on each side of the Generator to ensure proper air circulation.

The Generator may be placed directly on a work bench or mounted in a standard (24-inch deep) equipment rack. Use the Fluke Y6001 Rack Mount Kit for mounting the Generator on an equipment rack. Instructions for installing the Generator with the Rack Mount Kit are provided in the kit. The outside dimensions of the Generator are shown in Figure 2-2. The Rack Mount Kit is composed of the following parts:

- 5¼-inch Rack Adapter, P/N M05-205-600
- 24-inch Rack Slides, P/N M00-280-610

2-8. GENERAL OPERATING INFORMATION

The following paragraphs contain general information on the operation of the Generator. This includes all the information required to familiarize the operator with the instrument and the differences between local and remote operation.

2-9. Familiarization

The Generator normally operates on an internal reference oscillator. However, if desired, the Generator can be operated on an external reference by setting the rear panel REF INT/EXT switch to EXT and connecting the external reference to the REE IN connector.

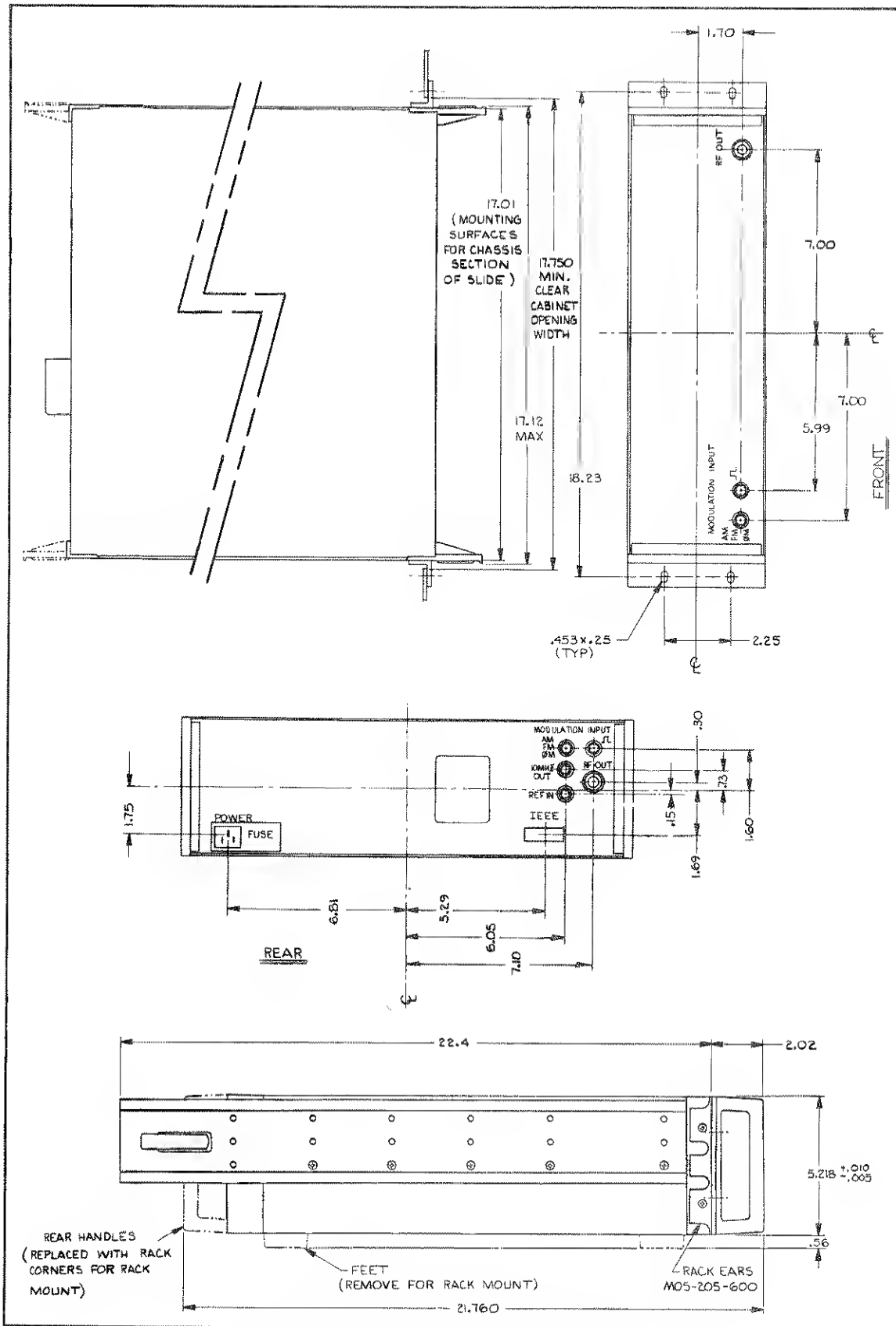

Figure 2-2. 6062A Outside Dimensions

CAUTION

When the Generator is operating on the internal reference, a 10-MHz signal is present at the 10 MHz OUT connector on the rear panel. To meet the specified radiated emissions, this connector must be terminated with a BNC non-shorting dust cap. A dust cap, JF 478982, is supplied with the Generator. If a cable is connected, it must be a double-shielded coaxial cable such as RG-223 terminated in a 50-ohm load.

CAUTION

Output spectral degradation occurs if the Generator is operated on internal reference with an external reference signal applied.

Figure 2-3 shows the front panel controls, indicator, and connectors and Table 2-1 describes the features.

Figure 2-4 shows the rear panel controls, connectors, and switches and Table 2-2 describes the features.

2-10. Local Versus Remote Operation

Two modes of controlling the output of the Generator are local operation and remote operation. In the local operation mode, the operator uses the keys on the front panel to control the Generator. The remote operation mode uses an IEEE-488 controller to control the Generator through the IEEE-488 Interface. An overview of local operation is presented under the heading Local and Remote Control Operations. The local and remote control operations that have similar entry methods are also described under Local and Remote Control Operations. The paragraphs under the heading Remote Operation contain information on commands or descriptions that pertain only to remote operations.

2-11. Power-On Sequence

When the Generator is turned on, a power-on sequence starts. During the power-on sequence, the microprocessor tests the analog circuitry, the program ROM, the scratch-pad RAM, the compensation memory, and the front panel displays. The front panel displays are tested by lighting all segments for a brief period at the same time the rest of the self tests are performed.

If any of the self tests fail, an error code is displayed. If the operator initiates any front panel entry before the power-on sequence is completed, the self test is aborted, and the Generator is set to the state it was in when turned off. Table 2-3 lists the Instrument Preset State. Power-on instrument settings that relate to the IEEE-488 Interface are described in the Remote Operation paragraphs in this section. More detail on the power-on self tests are explained in Section 4D.

2-12. Changing Output Parameters

The six parameters of the Generator (i.e., frequency, amplitude, amplitude modulation (AM), frequency modulation (FM), phase modulation (ϕ M), and pulse modulation) may be individually changed by at least one of three methods:

- Function Entry
- Bright-Digit Edit Entry
- Step Entry

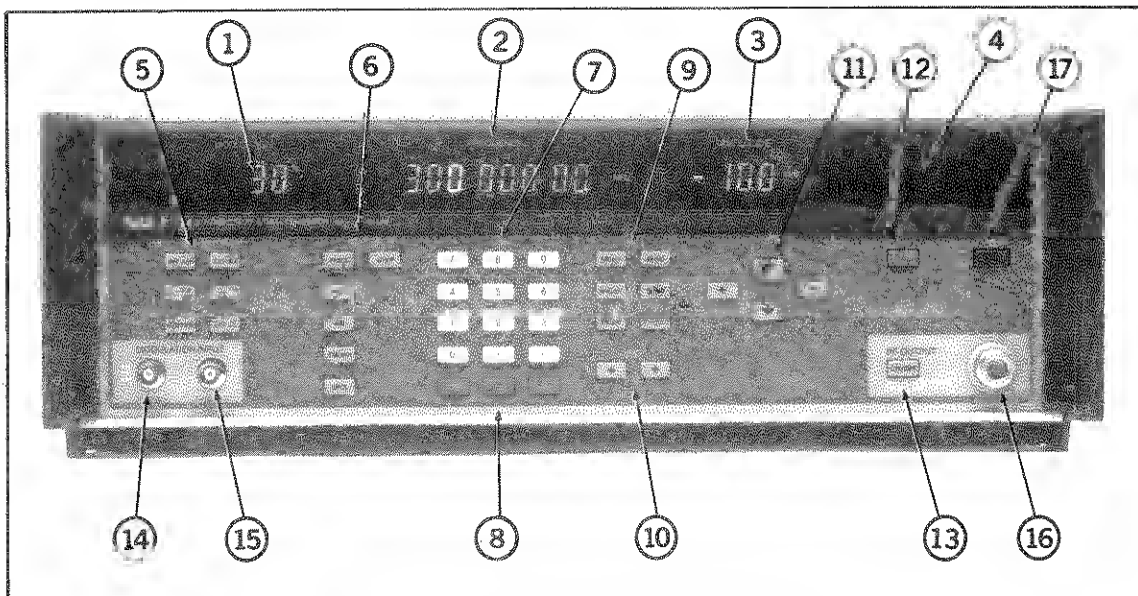

Figure 2-3. Front Panel Controls, Indicators, and Connectors

Table 2-1. Front Panel Controls, Indicators, and Connectors



①	MODULATION DISPLAY FIELD	A three-digit display, with associated indicators used to display the AM depth, FM deviation, source of modulation signal, and modulation frequency.
	INT AM	Indicates that the internal modulation oscillator signal is amplitude modulating the Generator.
	EXT AM	Indicates that the Generator is amplitude modulated by the signal connected to the MOD INPUT connector.
	INT FM	Indicates that the internal modulation oscillator signal is frequency modulating the Generator.
	EXT FM	Indicates that the Generator is frequency modulated by the signal connected to the MOD INPUT connector.
	INT \emptyset M	Indicates that the internal modulation oscillator signal is phase modulating the Generator.
	EXT \emptyset M	Indicates that the Generator is phase modulated by the signal connected to the MOD INPUT connector.
	INT 	Indicates that the internal modulation oscillator signal is pulse modulating the Generator.
	EXT 	Indicates that the Generator is pulse modulated by the signal connected to the PULSE MODULATION INPUT connector.
	STEP	Indicates that the Step [^] or [v] keys (Step Entry) affect the current Modulation display value.
	%	Indicates that the value displayed is the AM Depth in percent.
	kHz DEV	Indicates that the value displayed is the FM Deviation in kHz.
	rad	Indicates that the value displayed is the Phase Modulation Deviation in radians.

Table 2-1. Front Panel Controls, Indicators, and Connectors (cont)

	dBm	Indicates that the value displayed is the target level in dBm when performing a level compensation procedure.
	400 Hz	Indicates that the internal modulating frequency is 400 Hz.
	1000 Hz	Indicates that the internal modulating frequency is 1000 Hz.
	EXT HI	Indicates that the external modulation signal is more than 2% above the nominal 1V peak requirement for calibrated operation.
	EXT LO	Indicates that the external modulation signal is more than 2% below the nominal 1V peak input requirement.
②	FREQUENCY DISPLAY FIELD	A 9-digit display, with six indicators used to display the output frequency of the Generator. Also used to display the special function code, status error codes, or the memory location being stored or recalled, as well as relative and actual frequency, when REL is lit, and step frequency.
	STEP	Indicates that the STEP [^] or [v] keys (Step Entry) affect the output frequency.
	REL	Indicates that the displayed frequency is relative to a reference frequency.
	COMP	Indicates that the compensation memory protection switch on the A2 Controller PCA is set to the enabled position.
	FM	Indicates that an FM compensation procedure is in progress
	OUT	Indicates that an Output compensation procedure is in progress
	ATT	Indicates that an Attenuator compensation procedure is in progress.
③	AMPLITUDE DISPLAY FIELD	A 3 1/2- (and sign) digit display, with six indicators, used to display the output amplitude of the Generator into a 50-ohm load.
	STEP	Indicates that the STEP [^] or [v] keys (Step Entry) affect the output amplitude.
	REL	Indicates that the displayed amplitude is relative to a reference amplitude.
	dBm	Indicates that the output amplitude is in decibels relative to one milliwatt.
	V	Indicates that the output amplitude is in volts.
	uV	Indicates that the output amplitude is in microvolts.
	mV	Indicates that the output amplitude is in millivolts.
④	STATUS DISPLAY FIELD	The status display field is composed of 11 indicators used to denote the current status of the Generator or instrument entry.
	EXT REF	Indicates that the rear panel REF switch is in the EXT (external) position.

Table 2-1. Front Panel Controls, Indicators, and Connectors (cont)

REJ ENTRY	Lights when an invalid entry is made.
UNCAL	Lights when a parameter entry is outside its specified range. This indicator flashes when any of the internal DAC's are over or under-flow or when any abnormal operation is detected.
RF OFF	Lights when the RF OUTPUT is disabled.
REMOTE	Lights when the Generator is in the remote (IEEE-488 Interface) mode of operation.
ADDR	Lights when the Generator is addressed to listen or talk.
SRQ	Lights when the Generator has asserted the IEEE-488 SRQ signal.
5 MODULATION ON/OFF	Used to select type, source, and frequency of modulation. With the exception of the [400/1000] key, these keys operate as independent push-on/push-off switches for the given function. Any combination is allowed.
INT AM	Enables internal amplitude modulation at the frequency annunciated by the 400/1000 Hz indicator.
INT FM ØM	Enables internal frequency modulation at the frequency annunciated by the 400/1000 Hz indicator.
EXT AM	Enables external amplitude modulation using the signal applied to the MOD INPUT connector.
EXT FM ØM	Enables external frequency modulation using the signal applied to the MOD INPUT connector.
EXT 	Enables external pulse modulation using the signal applied to the PULSE MODULATION INPUT connector.
400/1000	Alternately sets the internal modulation oscillator's frequency to 400 or 1000 Hz. Selected frequency is displayed only when INT AM, FM, ØM, or internal pulse is enabled.
6 FUNCTION	With the exception of the [STEP] and [SPCL] keys, these keys operate as interlocked switches that select the parameter to be entered or edited. For the [FREQ], [AMPL], [AM], and [FM] FUNCTION keys, the bright digit appears in the corresponding display of the selected function.
FREQ	Selects the frequency parameter of the Generator to be programmed by using the DATA, EDIT, or STEP entry keys.
AMPL	Selects the amplitude parameter of the Generator to be programmed by using the DATA, EDIT, or STEP entry keys.
AM	Selects the amplitude modulation (AM) parameter of the Generator to be programmed by using the DATA, EDIT, or STEP entry keys.
FM ØM	Selects the frequency modulation (FM), or phase modulation (ØM) parameter of the Generator to be programmed by using the DATA, EDIT, or STEP entry keys.

Table 2-1. Front Panel Controls, Indicators, and Connectors (cont)

SPCL	Enables the special function mode. Special functions are called up by a two-digit code, that is entered by using the DATA keys. Refer to the paragraphs on Special Function in this section for a detailed description and a list of the special functions.
STEP	After one of the four parameter functions has been selected for programming, pressing this key allows you to program a step-wise change to that parameter. The step increase or decrease is then performed every time the STEP [^] or [v] keys are pressed.
⑦ DATA	A ten-digit (plus sign and decimal key) keypad used for entering a parameter's value, the special function code, or a memory recall/store location.
⑧ Memory	
STO	Used with the DATA keys to store the current instrument state in a memory location. Memory locations 01 through 50 are available.
RCL	Used with the DATA keys to recall an instrument state from a memory location. Memory locations 01 through 50 are available for operator-stored states; memory location 98 contains the Instrument Preset State (see Table 2-3.)
SEQ	Sequentially recalls, in increasing location order, the instrument states stored in memory. While the [SEQ] key is pressed, successive memory locations are displayed. When the key is released, the location last displayed is recalled.
⑨ UNITS	These keys, with the exception of [CLR/LCL], serve as the terminating keystroke of a function entry, thereby causing the Generator to be programmed. The amplitude units keys are also used during Amplitude Units Conversion entries.
MHz V	Used with the [FREQ], [FM], and [AMPL] function keys to program the numerical DATA entries in terms of megahertz (frequency or frequency modulation) or volts (amplitude).
dB(m)	Used with the [AMPL] function key to program the numerical DATA entries in terms of decibels per milliwatt.
kHz mV	Used with the [FREQ], [FM], and [AMPL] function keys to program the numerical DATA in terms of kilohertz (frequency or frequency modulation) or millivolts (amplitude).
% rad	Used with the [AM] function key to program the numerical DATA entries in terms of percentage AM depth. Also used with the [FM θM] function key to program the numerical DATA entries in terms of radians.
Hz uV	Used with the [FREQ], [FM], and [AMPL] function keys to program the numerical DATA in terms of hertz (frequency or frequency modulation) or microvolts (amplitude).
CLR LCL	When the Generator is in local operation, this key is used to clear the current entry and returns the Generator to the previous state. When the instrument is in remote operation, this key is used to return local control.

Table 2-1. Front Panel Controls, Indicators, and Connectors (cont)

⑩	STEP	These two keys work in conjunction with the STEP Function key. These keys repeat while they remain pressed.
	[^]	After a parameter is set to the step function mode, and the STEP indicator appears in the display field, this key increments the parameter by the step value previously programmed.
	[v]	After a parameter is set to the step function mode, and the STEP indicator appears in the display field, this key decrements the parameter by the step value previously programmed.
⑪	EDIT	These keys are used to position the bright digit within a display field and to increase or decrease the bright digit value. All four keys repeat while they remain pressed. The function keys are used to move the bright digit to the desired display field.
	[^]	Increases the bright-digit value.
	[<]	Moves the bright digit one digit to the left.
	[v]	Decreases the bright-digit value.
	[>]	Moves the bright digit one digit to the right.
⑫	STATUS	A push and hold key that displays the Uncal and Reject Entry status codes in the MODULATION, FREQUENCY, and AMPLITUDE display fields.
⑬	ON/OFF	A push-on/push-off key (with a corresponding RF OFF indicator in the STATUS display field) that enables or disables the output of the Generator.
⑭	Connector	A BNC connector for input of a 1V peak, external modulation signal.
⑮	Connector	A BNC connector for input of a 1V peak, external pulse modulation signal.
⑯	Connector	A standard RF connector at the output of the Generator.
⑰	POWER	A push-on/push-off detent switch that applies line power to the Generator.

These different methods all accomplish the same result but use different approaches for different reasons. One is to reduce the chance of error during complex test procedures that require continuously resetting parameters. Another is in the case when a test is partly under remote control and only some of the parameters require changes.

2-13. FUNCTION ENTRY

Changing an instrument parameter with the Function Entry method consists of:

- Selecting the function to be changed
- Entering the new numerical value of the parameter
- Selecting the units of the numerical value (megahertz, millivolts, etc).

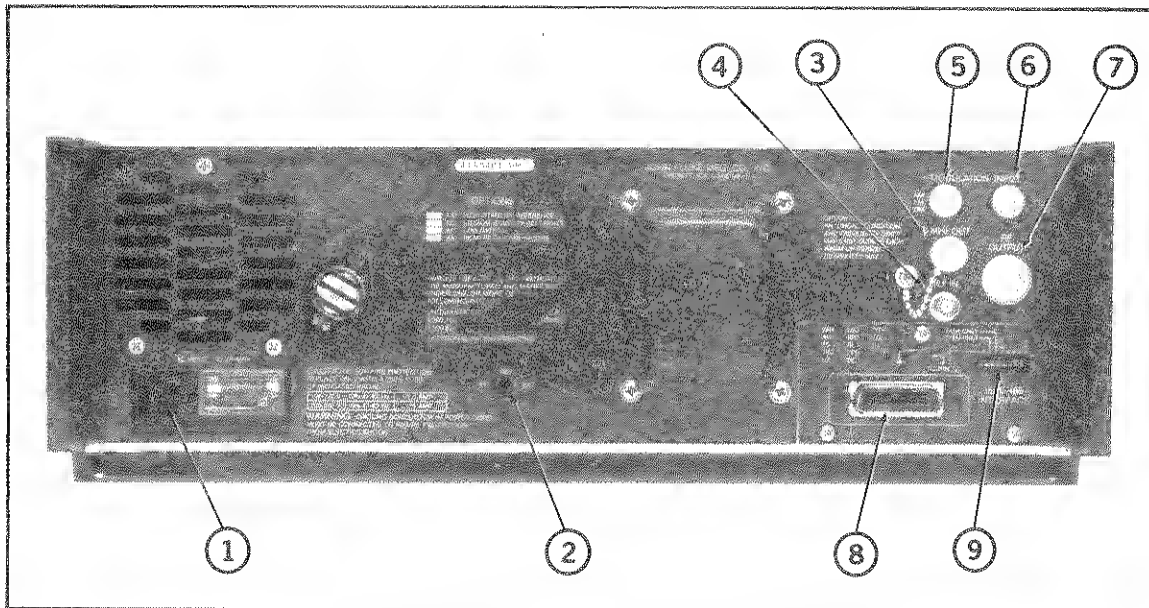

Figure 2-4. Rear Panel Controls, Connectors, and Switches

Table 2-2. Rear Panel Controls, Connectors, and Switches

①	AC INPUT	Permits operation from 100, 120, 220, or 240V ac. The number visible through the window on the selector card indicates the nominal line voltage to which the Generator must be connected. The line voltage is selected by orienting the selector card appropriately. A 1 1/2-ampere fuse is required for 100/120V operation and a 3/4-ampere fuse is required for 220/240V operation.
②	REF INT/EXT	Permits selection of the Generator frequency reference. When set to INT, the Generator operates on the internal reference, which is either the standard oscillator, the high-stability oscillator (if the Option -130 is installed) or the medium-stability oscillator (if the Option -132 is installed). In any case, the internal 10-MHz reference signal is available at the 10 MHz OUT connector. When set to EXT, the Generator reference is the 10-MHz signal applied to the external REF IN connector.
③	10 MHz IN/OUT	Connector (BNC) provides the 10-MHz reference signal.
④	REF IN	Connector (BNC) is present to accept a 1-, 2-, 2.5-, 5-, or 10-MHz, 0.3 to 4V p-p sine or square wave signal into nominally 50 ohms.
⑤	MOD INPUT	Connector (BNC) is present only with the Option -830 to accept a 1V peak external modulation signal.
⑥	⎓ MOD INPUT	Connector (BNC) is present only with the Option -830 to accept a 1V peak external pulse modulation signal.
⑦	RF OUTPUT	Connector (type N) is present only with the Option -830 to provide the Generator output signal.
⑧	IEEE CONNECTOR	Allows remote operation of the Generator via the IEEE-488 bus.
⑨	IEEE ADDRESS SWITCH	Allows the selection of the Generator bus address.

Table 2-3. Instrument Preset State

FUNCTION	SETTING
Frequency	300.00000 MHz
Frequency Step	1.00000 MHz
Amplitude	-10.0 dBm
Amplitude Step	1 dB
Modulation Rate	1000 Hz
AM Depth	30%
AM Depth Step	1 %
FM Deviation without/with Option -651	5.0/1.5 kHz
FM Deviation Step without/with Option -651	100/10 Hz
Modulation Display	AM Depth
Bright-Digit Location	Frequency Bright Digit
Frequency Bright-Digit Position	1 MHz
Amplitude Bright-Digit Position	1 dBm
AM Bright-Digit Position	1 %
FM Bright-Digit Position without/with Option -651	10/1 Hz
Special Functions	20,30,40,50,60,70,80,90
INT AM	Off
EXT AM	Off
INT FM	Off
EXT FM	Off
EXT PULSE	Off
Step Function	Frequency Step

The command syntax for function entries is:

Select Function — Enter Data — Select Unit

1. Select one of the four parameters using the FUNCTION keys. The bright digit appears in the corresponding display field. The presence of the bright digit in the display field indicates that the value of the selected parameter is ready to be programmed or changed.
2. Enter the numeric data with the DATA keys. The numerics appear in the appropriate display field.
3. Select a UNITS key. This gives the data its absolute value and causes the microprocessor to internally program the Generator to the new state.

For the amplitude and frequency functions, the entered data programs the displayed value. If the relative mode is enabled, the displayed value may be different from the actual output value.

Once a function is selected, the selected parameter or feature remains in the active programming mode until a new function is selected. Data for a selected parameter must be followed by a unit value and must be within the range specified for the function. The display field flashes, and the REJ ENTRY status indicator flashes if the entered data is not within the specified range. A rejected entry does not affect the output of the Generator. The output of the Generator remains at its previous values until a new value is accepted.

The function entry may be terminated at any time by the [CLR|LCL] key or by selecting another function.

2-14. BRIGHT-DIGIT EDIT ENTRY

Changing an instrument parameter by the bright-digit edit entry method is the fastest way to make vernier (incremental) changes to one of the four parameters. The EDIT keys are used

with the four parameter FUNCTION keys to position the bright digit in the desired display field and then increase or decrease the bright-digit value.

The command syntax for bright-digit edit entries is:

Select Display Field — Position Bright Digit — Change Bright-Digit Value

1. Use one of the four FUNCTION keys to position the bright digit in the appropriate display field.
2. Use the [→] or [←] EDIT keys to position the bright digit to the desired resolution, and use the [↑] or [↓] EDIT keys to increase or decrease the value of the bright digit.

The position of the bright digit within a display field is maintained when the bright digit is moved from one display field to another and then back to the original display field.

The repeat rate of the [↑] or [↓] EDIT keys may be changed to a faster or slower rate (a medium repeat rate is the default) with a special function code (see Table 2-4). Refer to the paragraphs on Special Function later in this section for the method and code.

2-15. STEP ENTRY

Changing parameters by the step entry method allows the operator to preset stepwise increments of a parameter, then change that parameter (by the amount programmed in the step function) with a single keystroke.

The command syntax for step entries is:

Select Step Function — Enter Data — Select Units — Change Parameter

1. Select the parameter to be changed stepwise using one of the FUNCTION keys followed by the [STEP] key to enable the step function.
2. Program the numeric step amount using the DATA keys.
3. Select a UNIT key to give the data its absolute value.
4. The parameter value can now be changed by increments of the programmed step amount by using the [↑] or [↓] STEP keys.

While the [STEP] key is pressed, the display field of the selected parameter shows the step amount. The STEP indicator is lit in the display field currently affected by the [STEP] key.

The repeat rate of the [↑] or [↓] STEP keys may be changed to a faster or slower rate (a medium repeat rate is the default) with a Special Function code. Refer to the paragraphs on Special Functions for the method and code.

A step entry is ignored when the result of that step entry would cause the value of the parameter to exceed its programmable limit.

2-16. Status and Clear

The [STATUS] key allows the operator to interrogate the Generator for an explanation of uncalibrated or rejected entry operation (UNCAL or REJ ENTRY indicator is lit). Refer to the paragraphs on Status and Clear Entry later in this section for a complete list of status codes.

Table 2-4. Special Functions

SPECIAL FUNCTION	OPERATION
00	Clear all special functions.
02	Initiate self tests.
03	Display test. See Section 3.
04	Key test. See Section 3.
07	Set SRQ.
08	Reset SRQ.
09	Display software revision level. Information appears in the MODULATION and FREQUENCY display fields for 5 seconds or until another key is pressed.
10	Display IEEE-488 mode and address
11	Display self-test results. Zeros in the display fields indicate that the self tests have passed. See Section 4.
12	Turn on displays.
13	Turn off all displays. All other functions still operate.
14	Initialize memory locations to Instrument Preset State. Sto ? appears in the FREQUENCY display field for 5 seconds. If during this time, the [STO] key is pressed, all memory locations are initialized.
15	Latch test. See Section 4.
16	Display option loading. See Interrogate Commands in this section.
17	Initiate self test with RF on. See Section 4.
20	Disable Relative Frequency. See Relative Function in this section.
21	Enable Relative Frequency. See Relative Function in this section.
30	Disable Relative Amplitude. See Relative Function in this section.
31	Enable Relative Amplitude. See Relative Function in this section.
40	Disable Internal Pulse Modulation. See Modulation Entry in this section
41	Enable Internal Pulse Modulation. See Modulation Entry in this section
50	Select dBm Amplitude Display Mode. See Amplitude Units Selection in this section.
51	Select dBmV Amplitude Display Mode. See Amplitude Units Selection in this section.
52	Select dBuV Amplitude Display Mode. See Amplitude Units Selection in this section.
60	Disable DC AM mode. See Modulation Entry in this section.
61	Enable DC AM mode. See Modulation Entry in this section.
70	Set repeat rate for EDIT and STEP keys to medium.
71	Set repeat rate for EDIT and STEP keys to fast.
72	Set repeat rate for EDIT and STEP keys to slow.
75	Display Compensation Memory status. See Section 4.
76	Repair Compensation Memory Errors. See Section 4.
77	Load FM MEC PROM data into Compensation Memory. See Section 4
78	Load Output MEC PROM data into Compensation Memory. See section 4.
79	Load Attenuator MEC PROM data into Compensation Memory. See section 4.
80	Enable Amplitude correction. Normal operation.
81	Disable Amplitude correction. RF output level may be up to 12 dB low.
82	Disable attenuator correction. Useful as a troubleshooting tool. RF input to attenuator is flat.
83	Program alternate 24 dB attenuation. See Section 4.
84	Program alternate 24 dB attenuation. See Section 4.
85	Program alternate 24 dB attenuation. See Section 4.
86	Program alternate 24 dB attenuation. See Section 4.
90	Disable Amplitude Fixed Range. See Amplitude Fixed Range in this section.
91	Enable Amplitude Fixed Range. See Amplitude Fixed Range in this section.
95	Initiate FM Keyboard Compensation Procedure. See Section 4E.
96	Initiate Output Keyboard Compensation Procedure. See Section 4E.
97	Initiate Attenuator Keyboard Compensation Procedure. See Section 4E.
98	Initiate Output with Default Attenuator Data Keyboard Compensation Procedure. See Section 4E.

The [CLR|LCL] key may be used to clear a partial DATA entry or clear the flashing REJ ENTRY indicator.

2-17. RF Output On/Off

The RF OUTPUT [ON/OFF] key allows the operator to enable or disable the RF output of the Generator. This feature is useful in zeroing a power meter, finding the noise floor of a system, or determining the presence or source of an unknown signal.

At power-on, the RF output of the Generator assumes the state it was in when the Generator was turned off. Pressing the RF OUTPUT [ON/OFF] key disables the output of the Generator and causes the RF OFF indicator (in the STATUS display field) to light. If the RF ON/OFF was off at power-on, pressing the [ON/OFF] key will enable output.

2-18. Modulation On/Off and Rate

The MODULATION ON/OFF keys allow the operator to select any combination of modulation or no modulation. The MODULATION display field indicates what combination of modulation has been selected. Each modulation key is a push-on push-off type (except the [400/1000] key).

The [400/1000] key toggles the internal modulation oscillator between 400 and 1000 Hz. The 400 Hz and 1000 Hz indicators are lit only when Internal AM, FM, ϕ M, or Pulse modulation is enabled.

2-19. Memory

Memory entry using the [STO] key allows the operator to save up to 50 complete front panel settings for later recall. No memory location needs to be specified for the sequence operation.

The command syntax for memory entries is:

Select Memory Function — Enter Memory Location

1. Store the current front panel setting by pressing the [STO] key (located below the DATA keys). The last memory location stored or recalled is displayed in the FREQUENCY display field.
2. Use the DATA keys to enter the two-digit memory location code. The location code must contain both digits (e.g., 01, 02, ...50). The two-digit code appears in the FREQUENCY display field as it is entered.
3. Recall a front panel setting by pressing the [RCL] key (located below the DATA keys). The last memory location stored or recalled is displayed in the FREQUENCY display field.
4. Use the DATA keys to enter the memory location code of the desired front panel setting. Remember, the location code must contain both digits of the memory location code.

Memory location 98 contains the Instrument Preset State that can be recalled at any time.

The [SEQ] key allows the front panel settings stored in memory to be sequentially recalled. This process is activated by pressing the [SEQ] key at any time. When the [SEQ] key is pressed, the memory location code of the currently recalled setting appears in the FREQUENCY display field, and the location is recalled. When the last memory location is reached (50), the [SEQ] key starts over at 01. The [SEQ] key repeats while pressed.

2-20. Software Compensation Procedures

The software compensation procedures allow the operator to update the instrument-specific compensation data after making related repairs. These procedures are easy to use and may be performed via the front panel (local) or under computer control (remote) through the IEEE-488 Interface. The local procedures enable secondary functions for many of the keys. Each remote procedure enables a special set of compensation commands and disallows much of the standard IEEE-488 command set. See Section 4E, Software Compensation Procedures, for details.

2-21. Special Function

Special function entries allow the operator to enable several special operating functions in the Generator. For example, special functions allow the operator to change the repeat rate of the STEP and EDIT keys, start the self tests, display the results of the power-on self tests, display the IEEE-488 address, enable relative and fixed-range features, and disable or enable special attenuation features. A complete list of the special functions available is presented in Table 2-4.

The command syntax for special function entries is:

Select Special Function — Enter Special Function Code

1. Select the special function by pressing the [SPCL] key.
2. The special function code is entered using the DATA keys.

2-22. LOCAL AND REMOTE CONTROL OPERATIONS

The following paragraphs describe local and remote operations that have similar entry methods for each Generator function. The functions are arranged in alphabetical order. The syntax of the command and allowable data ranges are for each function. Other information is also presented.

2-23. Amplitude and Frequency Entry

The following information describes how to control the carrier frequency and amplitude by the FUNCTION-DATA-UNIT entry sequence. This method applies to both normal and relative operations. The frequency display is a fixed-point display in MHz. The amplitude display is fixed point while displaying dBm but is floating point when displaying voltage units.

The RF OUTPUT [ON/OFF] must be enabled for the Generator to produce an output. (See the reference material on RF OUTPUT ON/OFF Entry.)

Command Syntax:

Select Function — Enter Data — Select Unit

INSTALLATION AND OPERATION

Summary:

	COMMAND	RANGE	RESOLUTION	NOTES
Set Frequency				
Local:	[FREQ] -- DATA -- [MHz V] [kHz mV] [Hz uV]	0.1 to 2100 MHz	10/20 Hz	1,2,3
Remote:	"FR" -- float -- "GZ" "MZ" "KZ" "HZ"	0.1 to 2100 MHz	10/20 Hz	1,2,4
Set Amplitude				
Local:	[AMPL] -- DATA -- [dB(m)] [MHz V] [kHz mV] [Hz uV]	-137 to +13/16 dBm 0.032 uV to 1.41/1.58 V 3 digits	0.1 dBm	3,5,6
Remote:	"AP" -- float -- "DB" "V" "MV" "UV" "NV"	-137 to +13/16 dBm 0.032 uV to 1.41/1.58 V 3 digits	0.1 dBm	4,5,6

Example:

Set Frequency to 10.7 MHz and Amplitude to -7.5 dBm.

Local: [FREQ] [1] [0] [.] [7] [MHz|V]
[AMPL] [-] [7] [.] [5] [dB(m)]

Remote: "FR10.7MZ,AP-7.5DB"

Notes:

1. Frequency ranging occurs at 245, 512, and 1050 MHz.
2. Frequency may be programmed with 10 Hz resolution when frequency < 1050 MHz, and with 20 Hz resolution when frequency ≥ 1050 MHz.
3. FUNCTION ([FREQ] or [AMPL]) remains selected until another FUNCTION or [STEP], [STO], [RCL], or [SPCL] is pressed.
4. Floating-point number is indicated by the word float.
5. Amplitude uncalibrated range from -147.4 to -137.1 dBm. Also uncalibrated from +16.1 to +17 dBm when frequency < 1050 MHz, and from +13.1 to +17 dBm when frequency ≥ 1050 MHz.
6. Amplitude ranging occurs at 1/2V, 1/4V, 1/8V, ... 1/2²³V with AM off and 1/4V, 1/8V, 1/16V, ... 1/2²⁴V with AM on.

Related Operations:

- Amplitude Fixed Range
- Amplitude Units Conversion
- Amplitude Units Selection
- Bright-Digit Edit Entry
- Relative Function
- Step Entry

2-24. Amplitude Fixed Range

The following information describes how to use the Fixed-Range special function. This special function fixes the current amplitude range (holds the currently selected step of the Step Attenuator). This function allows monotonic and nontransient level control over a limited range around those levels where the Step Attenuator normally autoranges. This level control may be accomplished with the Bright-Digit Edit Entry only.

The level vernier in fixed range has at least 18 dB of range (the specified accuracy range is 12 dB).

Command Syntax:

Select Fixed Range — Enable or Disable

Summary:

COMMAND	NOTES
Enable Fixed Range	
Local: [SPCL] [9] -- [1]	1
Remote: "SP" "9" -- "1"	
Disable Fixed Range	
Local: [SPCL] [9] -- [0]	2
Remote: "SP" "9" -- "0"	

Example:

Set the Generator for monotonic and nontransient amplitude control (Bright-Digit Edit only) over the range of the vernier level control below 0.25V.

```
Local: [AMPL] [.] [2] [5] [MHz|V] [SPCL] [9] [1]
Remote: "AP.25V,SP91"
```

Notes:

- 1 The amplitude range is fixed only for Bright-Digit Edit operations. Other methods of changing the amplitude cause the step attenuator to autorange if necessary.
- 2 With amplitude fixed range disabled, amplitude ranging occurs at 1/2V, 1/4V, 1/8V, ... 1/2²³V with AM off and 1/4V, 1/8V, 1/16V, ... 1/2²⁴V with AM on.

Related Operations:

Bright-Digit Edit Entry
Relative Function

2-25. Amplitude Units Conversion

The following information describes how to convert the displayed amplitude level from dBm to volts and from volts to dBm. The output of the Generator does not change during these operations.

Command Syntax:

Select Amplitude Function — Select Unit

Summary:

	COMMAND	NOTE
Convert dBm to volts:		
Local:	[AMPL] -- [MHz V] [kHz mV] [Hz uV]	1
Remote:	"AP" -- "V" "MV" "UV" "NV"	1
Convert volts to dBm:		
Local:	[AMPL] -- [dB(m)]	
Remote:	"AP" -- "DB"	

Example:

Change the displayed amplitude of -10.0 dBm to its voltage equivalent.

Local: [AMPL] [MHz|V]
Remote: "APV"

Note:

1. Any voltage unit is accepted since the microprocessor automatically selects the units appropriate for the value being displayed.

Related Operations:

Relative Function
Amplitude Units Selection

2-26. Amplitude Units Selection

The following information describes how to select the alternate level display units. When the level is displayed as a dB quantity, units of dBm, dBmV or dBμV may be selected by special function. Entering the special function code converts the displayed quantity to the selected units but does not change the output of the Generator.

Command Syntax:

Select Amplitude Units — Select Unit

Summary:

COMMAND	NOTE
Select dBm Display Units	
Local: [SPCL] [5] -- [0]	
Remote: "SP" "5" -- "0"	
Select dBmV Display Units	
Local: [SPCL] [5] -- [1]	
Remote: "SP" "5" -- "1"	
Select dBuV Display Units	
Local: [SPCL] [5] -- [2]	
Remote: "SP" "5" -- "2"	

2-27. Bright-Digit Edit Entry

The following information describes how to use a Bright-Digit Edit Entry to change an instrument parameter. The output frequency, amplitude, and modulation indexes can be modified with this entry method.

The RF OUTPUT [ON/OFF] must be enabled for the Generator to produce an output. (See the reference material on RF OUTPUT [ON/OFF] Entry.)

Command Syntax:

Select Display Field — Position Bright Digit — Change Bright-Digit Value

Summary:

COMMAND	NOTES
Edit Frequency	
Local: [FREQ] -- EDIT [<]/[>] -- EDIT [^]/[v]	1,2
Remote: "FB" -- float "GZ" -- "KF" float	3,4,5
"MZ"	
"KZ"	
"HZ"	

4. In remote, the bright digit is positioned within a display field using a decade value and associated unit. Minus signs are ignored.
5. In remote, the bright digit is moved to the corresponding field and is increased or decreased by the signed integer following the "KF,KA,KD,KP" messages. The generic edit command "KB" may also be used to edit up or down the current bright-digit position. Positive integers do not require a sign.

Related Operations:

Relative Function
Amplitude Fixed Range

2-28. Memory Entry

The following information describes how to use the memory function to store and recall front panel settings. The Generator has 50 memory locations that are retained for 2 years with the power off.

The sequence feature allows the operator to recall successive memory locations.

Command Syntax:

Select Memory Function — Enter Memory Location

Summary:

	COMMAND	NOTES
Store		
Local:	[ST0] -- [n] [n]	1,2,3
Remote:	"ST" -- int	1,4
Recall		
Local:	[RCL] -- [n] [n]	1,2,3
Remote:	"RC" -- int	1,4
Sequence		
Local:	[SEQ]	5,6
Remote:	"SQ"	5

Example:

Recall the Instrument Preset State (located in memory location 98). Change the frequency parameter to 302 MHz, then store the new front panel setting in memory location 06.

```
Local: [RCL] [9] [8] EDIT [^] [^] [ST0] [0] [6]
Remote: "RC98,KF2,ST6"
```

Notes:

1. The memory locations available for operator use are 01 through 50. Additionally, the following special memory locations are available:

Memory location 00 contains a backup-memory location. After a recall (or sequence) operation it contains the last front panel setting. After a store operation, it contains the data in the stored memory location before the store operation. Thus, a recall operation can be reversed by recalling location 00.

Memory location 98 contains the Instrument Preset State.

Memory location 99 contains the present instrument state.

2. In local control, two data digits must be entered to specify the memory location. The recall or store is performed when the second digit is released.
3. The last memory location specified (used for sequence operations) is displayed while the [STO] or [RCL] button is pressed.
4. An unsigned integer is indicated with int.
5. The sequence operation recalls the next higher memory location, starting from the last memory location stored or recalled. No memory location needs to be specified. When the highest location is reached, the sequence starts over again at location 01.
6. While [SEQ] is pressed, the next memory location number is displayed and the memory location is recalled. This key is repeating.

2-29. Modulation Entry

The following information describes how to preset the modulation index (AM depth or FM/ ϕ M deviation), internal modulation rate (400 or 1000 Hz), and how to select the modulation source (internal and/or external).

The FUNCTION-DATA-UNIT method of selecting the modulation index is summarized in the following command syntax. The indices may also be modified using Bright-Digit Edit or Step Entry. Since there is only one modulation display, the modulation index displayed is determined by the last modulation FUNCTION key pressed.

Command Syntax:

Select Function — Enter Data — Select Unit

Summary:

COMMAND	RANGE	RESOLUTION	NOTES
Set AM Depth			
Local: [AM] -- DATA -- [%]	0 to 99%	1%	1,2
Remote: "AM" -- float -- "PC"	0 to 99%	1%	1,2,3
Set FM Deviation			

Local: [FM ØM] -- DATA -- [MHz V]	0 to 400 kHz	3 digits	1,4,5
	[kHz mV]		
	[Hz µV]		
	[% rad]	0 to 40.0 rad	3 digits
Remote: "FM" -- float -- "GZ"	0 to 400 kHz	3 digits	1,3,4,5
	"MZ"		
	"KZ"		
	"HZ"		
	"RD"	0 to 40.0 rad	3 digits

Summary:

COMMAND	NOTES
Select Modulation Rate	
Local: [400/1000]	6
Remote: "MR" "0" or "1"	7

Summary:

COMMAND	NOTES
Enable or Disable AM, DCAM, FM/ØM or Pulse Modulation	
Local: [INT AM]	8,9
[INT FM ØM]	
[EXT AM]	
[EXT FM ØM]	
[EXT ]	
[SPCL] [4] -- [0] or [1]	10
[SPCL] [6] -- [0] or [1]	11
Remote: "AI" "0" or "1"	12
"FI" "0" or "1"	
"AE" "0" or "1"	
"FE" "0" or "1"	
"PE" "0" or "1"	
"PI" "0" or "1"	10,12
"DA" "0" or "1"	11,12

Example:

Set the FM deviation to 5 kHz, set the modulation rate to 400 Hz, and modulate the carrier internally.

```
Local: [FM|ØM] [5] [kHz] [INT FM] [400/1000]
Remote: "FMSKZ,MRO,F11"
```

Notes:

1. This operation does not change the Generator output unless the corresponding modulation is enabled.
2. Uncalibrated if peak amplitude exceeds +16 dBm when frequency <1050 MHz, or +13 dBm when frequency \geq 1050 MHz.
3. Floating-point number is indicated with the word float.
4. Uncalibrated if FM is enabled and FM deviation is above (frequency -150 kHz).
5. The maximum FM deviation is dependent on the output frequency. Deviations up to 400 kHz or 40.0 radians may be entered regardless of the output frequency; however, the UNCAL indicator is flashed if the limits specified in Table 4D-14 are exceeded. The maximum deviations are reduced to 40.0 kHz and 4.00 rad if the low-rate FM option is installed.
6. Toggles between 400 or 1000 Hz only. An indicator shows selected rate only if internal modulation is on.
7. "0" selects a modulation rate of 400 Hz; "1" selects 1000 Hz.
8. These are ON/OFF operations; any combination is allowed.
9. Two indicators EXT HI and EXT LO are lit when external AM or FM is on to indicate that the external modulation signal is 2% above or 2% below the nominal IV peak input requirement.
10. Internal pulse modulation can be enabled by special function or by the alternate IEEE-488 command "PI". It can be enabled with any combination of the above modulations.
11. The dc coupled AM mode can be enabled by special function or by the alternate IEEE-488 command "DA". The dc coupled AM mode works in conjunction with External AM and only affects the output of the Generator if External AM is also enabled.
12. "0" turns the modulation source off; "1" turns it on.

Related Operations:

Bright-Digit Edit
Entry Step Entry

2-30. Relative Function

The following paragraphs describe how to change frequency and amplitude using the relative mode. There are two steps:

- 1 Setting the reference
- 2 Changing the parameter relative to that reference

Setting the reference is done by setting the parameter to the desired value and then enabling the relative mode for that parameter. This causes the REL indicator to light and the displayed value to be zero in the corresponding display. The Generator output does not change during these operations. In the relative mode, the usual means of changing the parameter may be used; i.e., Function, Step, or Bright-Digit Edit Entry.

In the relative frequency mode, the actual frequency is the sum of the reference and the displayed frequency. The actual frequency may be displayed by pressing the [FREQ] key. If the 10/20 Hz frequency resolution boundary is crossed using the step or edit functions while in the relative frequency mode, a 10-Hz rounding quantity may be applied to the displayed frequency.

In the relative amplitude mode, the actual amplitude is the sum of the reference and the displayed amplitude when the reference and the displayed quantities have the same units. However, with mixed units (volts and dB), the actual amplitude is the voltage value scaled by the dB value. The actual amplitude may be displayed by pressing the [AMPL] key.

Command Syntax:

Select Relative Function — Enable or Disable

Summary:

	COMMAND	NOTE
Frequency		
Local:	[SPCL] [2] -- [0] or [1]	1
Remote:	"SP" "2" -- "0" or "1"	1
Amplitude		
Local:	[SPCL] [3] -- [0] or [1]	1
Remote:	"SP" "3" -- "0" or "1"	1

Example:

Set the amplitude to -15 dBV; i.e., 15 dB below 1 volt.

```
Local: [AMPL] [1] [MHz|V] [SPCL] [3] [1] [AMPL] [-] [1] [5] [dB(m)]
Remote: "AP1V,SP31,AP-15DB"
```

Note:

1. 1 enables the relative function; 0 disables the relative function.

Related Operations:

Amplitude and Frequency Entry
 Bright-Digit Edit Entry
 Step Entry

2-31. RF OUTPUT ON/OFF Entry

The following information describes how to enable the output of the Generator using the RF OUTPUT [ON/OFF] key and the corresponding remote code.

Command Syntax:

RF Output On/Off

Summary:

COMMAND	NOTE
RF Output On	
Local: RF OUTPUT [ON/OFF] when RF OFF is on	1
Remote: "R01"	1
RF Output Off	
Local: RF OUTPUT [ON/OFF] when RF OFF is off	
Remote: "R00"	

Note:

1. Turning the RF Output on resets the RPP circuitry if it has tripped.

2-32. Special Function Entry

The following information describes how to use the Special Function Entry to use the special operating functions of the Signal Generator. Table 2-4 lists the special functions available.

The special function code is a two-digit number. The first digit indicates the classification of the special function, and the second digit specifies the particular special function.

The special function is executed when the second special function code digit is entered. There are ten classes of special functions. The special functions in the 0(n) and 1(n) class cause an action to be performed. Classes 2(n) through 9(n) cause an instrument state to change. The status of classes 2(n) through 9(n) appears (left to right) in the frequency display field when the [SPCL] key is pressed. Table 2-4 describes the special functions available with the Generator.

Command Syntax:

Select Special Function — Enter Special Function Code

COMMAND	NOTE
Local: [SPCL] -- [n] [n]	
Remote: "SP" -- int	1

Example:

Change the repeat rate of the EDIT and STEP keys to slow.

Local: [SPCL] [7] [2]

Remote: "SP72"

Note:

1. Unsigned integer is indicated with int.

Related Operations:

Fixed Range
Relative Function

2-33. Status and Clear Entry

The status entry allows the operator to interrogate the Generator for an explanation of either uncalibrated operation (UNCAL indicator is lit) or rejected entry operation (the REJ ENTRY indicator is lit).

When either the UNCAL or REJ ENTRY indicator is lit, press and hold the [STATUS] key to display the Uncalibrated or Rejected Entry Error Code Message. These messages provide detailed information on the nature of the uncalibrated or rejected entry condition. Table 2-5 contains a list and explanation of all the Uncalibrated Error Code Messages. Table 2-6 contains a list and explanation of all the rejected entry error code messages.

The [CLR|LCL] key may be used to clear a partial DATA entry or clear the flashing REJ ENTRY indicator. Press the [STATUS] key while an UNCAL indication exists to display the uncal error codes in three fields:

Flashing codes (denoted by *) indicate abnormal operation or aberrated output. Non-flashing codes indicate operation outside the specified range.

Press the [STATUS] key while the REJ ENTRY indication exists to display the reject entry error codes:

2-34. Step Entry

The following information describes how to use the step entry function to change an instrument parameter. The RF OUTPUT [ON/OFF] must be enabled for the Generator to produce an output. (See the RF OUTPUT [ON/OFF] Entry information covered earlier in this section.)

Command Syntax:

Select Step Function — Enter Data — Select Units — Change Parameter

Summary:

COMMAND	RANGE	RESOLUTION	NOTES
Frequency			
Local: [FREQ][STEP]--DATA --[MHz V] --STEP [^]/[v]	[kHz mV] [Hz uV]		
	0 to 2100 MHz	10 Hz	

INSTALLATION AND OPERATION

```

Remote: "FS"      --float--"GZ"    --"FU"/"FD"
                  "MZ"
                  "KZ"
                  "HZ"
                  0 to 2100 MHz  10 Hz          1,2
  
```

Amplitude

```

Local: [AMPL][STEP]--DATA --[dB(m)] -- STEP [^]/[v]
                  [MHz|V]
                  [kHz|mV]
                  [Hz|uV]
                  0 to 164 dB    0.1 dB
                  0 nV to 1999 V 3 digits
  
```

```

Remote: "LS"      --float--"DB"    --"LU"/"LD"
                  "V"
                  "MV"
                  "UV"
                  "NV"
                  0 to 164 dB    0.1 dB        1,2
                  0 nV to 1999V 3 digits      1,2
  
```

FM/DM deviation

```

Local: [FM|DM][STEP] --DATA --[MHz|V] -- STEP [^]/[v]
                  [kHz|mV]
                  [Hz|uV]
                  [%|rad]
                  0 to 400 kHz   3 digits      3
                  0 to 40.0 rad 3 digits
  
```

```

Remote: "DS"      --float--"GZ"    --"DU"/"DD"
                  "MZ"
                  "KZ"
                  "HZ"
                  "RD"
                  0 to 400 kHz   3 digits      1,2,3
                  0 to 40.0 rad 3 digits
  
```

AM depth

```

Local: [AM][STEP] --DATA --[%]    -- STEP [^]/[v]
                  0 to 99%        1%
  
```

```

Remote: "PS"      --float--"PC"    --"PU"/"PD"
                  0 to 99%        1%          1,2
  
```

Example:

Recall the Instrument Preset State: [RCL] [9] [8]. Step the displayed frequency of 300 MHz, in 10-MHz steps, to 270 MHz.

```

Local: [FREQ] [STEP] [1] [0] [MHz|V] [v] [v] [v]STEP
Remote: "FS10MZ,FD,FD,FD"
  
```

Notes:

1. Floating-point number is indicated with the word float.

Table 2-5. UNCAL Error Codes

CODE	DESCRIPTION
000 000 000	= No UNCAL conditions
002 000 000	= FM Dev/φM > (freq -150 kHz)
*004 000 000	= Excess FM Dev/φM, main or reference PLL unlocked
*010 000 000	= FM DAC at full scale
200 000 000	= Multiple COMP memory checksum errors. See Compensation Memory Status in Section 2.
*000 010 000	= Main or reference PLL unlocked
000 000 001	= Level vernier > 12 dB below bottom of range
000 000 002	= Peak amplitude > +16 dBm for freq < 1050 MHz or > +13 dBm for freq ≥ 1050 MHz
*000 000 004	= Amplitude unlevelled
*000 000 010	= Fixed-range Level vernier at 0
*000 000 020	= Fixed-range Level vernier at full scale
*000 000 040	= RPP tripped
000 000 100	= Level < -137 dBm
000 000 200	= Level correction disabled
*000 000 400	= RF off

Flashing codes (denoted by *) indicate abnormal operation or aberrated output. Non-flashing codes indicate operation outside specified range.

Table 2-6. REJECT ENTRY Codes

CODE	DESCRIPTION
000 000 000	= No rejected entries
001 000 000	= FM Dev/φM not between 0 and 400 kHz (40.0 kHz with Option -651)
002 000 000	= FM Dev/φM Step not between 0 and 400 kHz (40.0 kHz with Option -651)
004 000 000	= AM Depth not between 0 and 99%
010 000 000	= AM Depth Step not between 0 and 99%
020 000 000	= IEEE-488 command syntax error
040 000 000	= IEEE-488 input value out of range
100 000 000	= MEC compensation PROM error
200 000 000	= IEEE edit or step operation beyond allowed range
400 000 000	= Invalid frequency in COMP memory
000 001 000	= Frequency not between 100 kHz and 2100 MHz
000 002 000	= COMP switch not enabled or low-rate FM option not disabled
000 004 000	= Frequency Step not between 0 and 2100 MHz
000 010 000	= COMP data may not be stored if procedure incomplete
000 020 000	= Invalid compensation command
000 040 000	= Invalid memory location
000 100 000	= Invalid data in memory
000 200 000	= Special function not allowed
000 400 000	= COMP data range error
000 000 001	= Output amplitude not between 10 nV and 1.58V
000 000 002	= Insufficient resolution for units conversion
000 000 004	= Units conversion to volts not allowed with reference in volts
000 000 010	= Units conversion to dB not allowed with reference in volts
000 000 020	= Amplitude Step not between 0 and 164 dB or 0 and 1999V
000 000 040	= Units conversion of Amplitude or FM/φM Step not allowed
000 000 100	= Amplitude or FM/φM step and current display not in same units
000 000 200	= COMP data from IEEE-488 out of range or edit beyond COMP limits
000 000 400	= Internal compensation data transfer error

2. Entering the step size from IEEE-488 does not select the step function. For example, "FS10MZ" does not select the step function; "FD" or "FU" must be used to select the frequency step function. The generic step up/down commands "SU" and "SD" may be used to step the current step function.
3. If the Low-Rate FM option is installed, the range of FM deviation steps is 0 to 40.0 kHz, and the range of φM deviation steps is 0 to 4.00 rad.

Related Operations:

Relative Function

2-35. REMOTE OPERATION (IEEE-488 INTERFACE)

The following paragraphs describe how to operate the Generator using the IEEE-488 Interface (referred to as remote operation). The interface allows the operator to program the Generator and operate instrument functions via the IEEE-488 bus (with the exception of the front panel POWER switch and the rear panel REF INT/EXT switch). The IEEE-488 Interface also provides additional programming features not accessible from the front panel.

The rest of this section is divided into two parts: the first part describes how to set up the Generator for operation on the IEEE-488 bus and gives some typical programming examples. The first part also includes a complete list of the programming commands recognized by the Generator software.

The second part describes the implementation of the IEEE-488 Interface and programming features that are accessible only from the IEEE-488 Interface. The second part also includes typical timing data, provided as an aid to system programmers. This information can assist in writing programs that have greater speed and efficiency.

The Generator can be used with any IEEE-488 controller in the normal addressed mode. The following two additional modes are available for operation without a controller:

- Listen-only mode
- Talk-only mode

In the listen-only mode, the Generator responds to all data messages on the IEEE-488 bus. In the talk-only mode, the Generator sends commands on the IEEE-488 bus to program another 606xA Generator (or a 607xA with some restrictions).

2-36. Setting Up the IEEE-488 Interface

Figure 2-5 shows a 6062A Signal Generator connected to a 1722A via the IEEE-488 bus.

Use the following procedure to set up the Generator with the IEEE-488 Interface:

1. Connect a standard IEEE-488 cable between the Generator and the IEEE-488 device.

NOTE

The IEEE-488 Interface signal SHIELD (pin 12) can be disconnected (when using an IEEE-488 cable without a metallic hood) from instrument ground. To do this, use the left most address switch (as viewed from the rear panel).

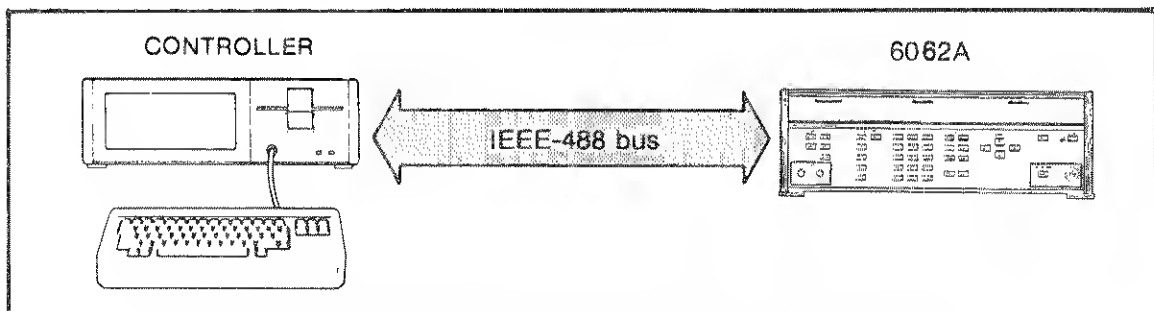

Figure 2-5. 6062A Synthesized RF Signal Generator Connected to a 1722A

2. Select the IEEE-488 address and mode as follows:
 - a. Set both the LISTEN ONLY and TALK ONLY switches (located on the rear panel of the Generator) to 0 (down). Set switches a1 through a5 to the desired address 0 through 30. For example, for an address of 1, set switches a2, a3, a4, and a5 to 0 (down), and set switch a1 to 1 (up).
 - b. For talk-only operation, set the TALK ONLY switch to 1 (up).
 - c. For listen-only operation, set the LISTEN ONLY switch to 1 (up) and set the TALK ONLY switch to 0 (down).
3. Verify the address and mode:
 - a. Press the [SPCL] and the [1][0] keys. Verify that the selected address appears in decimal in the FREQUENCY display field.
 - b. If the talk-only mode or listen-only mode has been selected, "to" or "lo" appears to the left of the address in the FREQUENCY display field.

NOTE

The address switches are continuously monitored except when in remote. The TALK ONLY and LISTEN ONLY switches are only read when the Generator is powered on.

2-37. Programming Commands

After the address and mode have been set, the Generator can be programmed by an IEEE-488 controller or from another generator. Tables 2-7 and 2-8 and the programming examples following them provide the basic information on how to program the Generator.

Table 2-7. Index of IEEE-488 Commands

FUNCTION	COMMAND HEADERS
Amplitude Entry	AP, SP3x, RA, SP5x, SP8x, SP9x
Binary Learn Commands	LI, LM
Clear Commands	CB, CE, CL
Compensation Mode Commands	CM
Compensation Procedure Commands	CF, CP, IC, IH
Edit Entry	AB, DB, FB, PB, KB, KA, KD, KF, KP
Frequency Entry	FR, SP2x, RF
Interface Mode Commands	EM, RM, TM, VM, UM, @
Interrogate Commands	IA, ID, IE, II, IL, IO, IR, IS, IT, IU, IV, IZ
Memory Entry	RC, ST, SQ
Modulation Entry	AM, AE, AI, SP6x, DA, FM, FE, FI, MR, MF, PE, SP4x, PI
Monitor Commands	IB, OB, OD, RB, RW, DW, WB, WW, XA, XB, XD, XR
RF ON/OFF Entry	RO
Special Function Entry	SP
SRQ Commands	IM, SM, XF
Step Entry	FS, LS, PS, DS, SU, SD, FU, FD, LU, LD, PU, PD, DU, DD
Trigger Commands	CT, TR

Table 2-8. IEEE-488 Commands

COMMAND USE	COMMAND			COMMENTS
	HEADER	NUMERIC	SUFFIX	
AMPLITUDE ENTRY				
Program Amplitude	AP	float	V MV UV NV DB	Program displayed amplitude in units of: volts millivolts microvolts nanovolts dB, dBm, dBmV or dBuV
Convert Amplitude Units	AP	none	V MV UV NV DB	Change amplitude units to: volts volts volts volts dB, dBm, dBmV or dBuV
Relative Amplitude	SP	30/31	none	Disable/enable relative amplitude operation
Relative Amplitude	RA	0/1		Alternate programming command for disable/enable relative amplitude operation.
Amplitude Display Units	SP	50 51 52	none	Select dBm units Select dBmV units Select dBuV units
Level Correction	SP	80 81 82	none	Enable all level correction. Disable all level correction. Disable attenuator correction.
Amplitude Fixed Range	SP	90/91	none	Disable/enable amplitude fixed-range operation.
BINARY LEARN COMMANDS				
Store a Front Panel Setup	LI	int	string	The Generator stores the string into the memory location specified by int. See the Command Description paragraph for decoding the learn string.
Send a Front Panel Setup	LM	int	none	The Generator responds with the contents of the memory location specified by int. See the Command Descriptions paragraph for decoding the learn string.
CLEAR COMMANDS				
Clear IEEE-488 Output Buffer	CB	none	none	Clears IEEE-488 output buffer.
Clear error	CE	none	none	Clears the IEEE-488 rejected entry status.

Table 2-8. IEEE-488 Commands (cont)

Device Clear	CL	none	none	Clears the instrument state and exits all compensation procedures.
COMPENSATION MODE COMMANDS				
Compensation Mode	CM	none	AT FM OD OT SV EX	Begin Attenuator compensation procedure. Begin FM compensation procedure. Begin Output with default attenuator compensation procedure. Begin Output compensation procedure. Save compensation data and exit compensation procedure. Exit compensation procedure without saving the data.
COMPENSATION PROCEDURE COMMANDS				
Compensation FM Entry	CF	float	GZ MZ KZ HZ	Accept FM deviation reading from modulation analyzer during FM compensation procedure.
Compensation Amplitude Entry	CP	float	DB	Accept amplitude reading from power meter during level compensation procedure.
Interrogate Compensation Step Data	IC	none	FR TG	Interrogate the frequency of the current compensation procedure step. Interrogate the target level or FM deviation of the current compensation procedure step.
Interrogate Het Adjustment Data	IH	none	none	Interrogate the frequency and level offset necessary to make the het compensation adjustment. For example, "+0000120000.,+00000000.30"<EOR> indicates the adjustment should be made at 120 kHz and the level needs to be adjusted up .3 dB.
EDIT ENTRY				
Position Amplitude Bright Digit	AB	float	V MV UV NV DB	Position the bright digit in the AMPLITUDE display with the stated resolution. For example, enter "AB10MV" for a 10-mV resolution.
Position FM Bright Digit	DB	float	GZ MZ KZ HZ RD	Position the bright digit in the FM display with the stated resolution. For example, enter "DB1KZ" for a 1-kHz resolution.

Table 2-8. IEEE-488 Commands (cont)

Position Frequency Bright Digit	FB	float	GZ MZ KZ HZ	Position the bright digit in the FREQUENCY display with the stated resolution. For example, enter "FB1MZ" for a 1-MHz resolution.
Position AM Bright Digit	PB	float	PC	Position the bright digit in the AM display with the stated resolution. For example, enter "PB1PC" for a 1% resolution.
Edit	KB	float	none	Edit the current bright digit by float counts.
Edit Amplitude	KA	float	none	Move the bright digit to the AMPLITUDE display and edit amplitude by float counts.
Edit FM	KD	float	none	Move the bright digit to the FM display and edit FM by float counts.
Edit Frequency	KF	float	none	Move the bright digit to the FREQUENCY display and edit frequency by float counts.
Edit AM	KP	float	none	Move the bright digit to the AM display and edit AM by float counts.
FREQUENCY ENTRY				
Frequency Programming	FR	float	GZ MZ KZ HZ	Program displayed frequency in units of: gigahertz megahertz kilohertz hertz
Relative Frequency	SP	20/21	none	Disable/enable relative frequency operation.
Relative Frequency	RF	0/1	none	Alternate programming command for disable/enable relative frequency operation.
INTERFACE MODE COMMANDS				
Error Mode	EM	0/1	none	Disable/enable the clear error mode. If disabled, the IEEE-488 error status is cleared only when interrogated. If enabled, the error status is cleared when a new message is processed.
Record Mode	RM	0/1	none	Disable/enable the record mode. If disabled, the message unit is a command. If enabled, a message unit is a record. The message unit is the smallest group of characters that the Generator processes.

Table 2-8. IEEE-488 Commands (cont)

Record Terminator Mode	TM	0/1	none	Selects the LF/CR character as the record terminator. The record terminator is used on input in the record mode and is sent following all output.
Output Valid Mode	VM	0/1	none	Disable/enable the output valid mode. In the output valid mode, the Generator waits to process commands until the RF output has become valid.
Unbuffered Mode	UM	0/1	none	Disable/enable the unbuffered mode. If disabled, all input is buffered. If enabled, only one message unit is buffered.
"@" Modes	@	int	none	The "@" command may be used as an alternate method of programming interface modes.
INTERROGATE COMMANDS				
Interrogate Attenuator Counts	IA	none	none	The Generator responds with seven counts. Each count indicates the total number of actuations for one of the seven attenuator sections in the Generator.
Instrument Identification	ID	none	none	The Generator responds with its model number, for example, "6062A".
Elapsed Time Indicator	IE	none	none	The Generator responds with the total operating time since the Generator was manufactured.
Interface Modes	II	none	none	Interrogate the interface modes selected. The Generator responds with an unsigned integer.
Interrogate Error Log	IL	none	none	The Generator responds with ten error log entries. Each entry is an uncal error code or a self test result and the elapsed time of when the error was logged.
Option Loading	IO	none	none	Interrogate the option loading. The Generator responds with the message: d1, d2, d3 d1 is the instrument code. d2 is the digital and synthesizer options. d3 is the output options. See the Interrogate Commands paragraphs for details.

Table 2-8. IEEE-488 Commands (cont)

Rejected Entry	IR	none	none	Interrogates the rejected entry error codes. The Generator responds with three octal fields: "AAAAAA,BBBBBB,CCCCCC". See Table 2-6 for a list of rejected entry error codes.
Serial Number	IS	none	none	Interrogates the instrument serial number.
Self Test	IT	none	none	Interrogates the results of the self tests. The Generator responds with the self-test results. See paragraph 4D-20 for self-test codes.
UNCAL	IU	none	none	Interrogates the uncalibrated output error codes. The Generator responds with three octal fields: "AAAAAA,BBBBBB,CCCCCC". See Table 2-5 for a list of uncal error codes.
Software Version	IV	none	none	Interrogate the software version. The Generator responds with the status message: "Vxx.x" where x's are decimal digits representing the current software revision level.
Compensation Memory Status	IZ	none	none	Interrogates the compensation memory status. The Generator Responds with three fields: "AAAAAA,BBBBBB,CCCCCC". See Table 4D-7 for a list of status codes.
MEMORY ENTRY				
Recall	RC	int	none	Recall the front panel setup stored at the memory location specified by int.
Store	ST	int	none	Store the current front panel setup at the memory location specified by int.
Sequence	SQ	none	none	Sequence (recall) to the next higher memory location.
MODULATION ENTRY				
Program AM	AM	float	PC	Program AM depth in percent.
External AM	AE	0/1	none	Disable/enable external AM
Internal AM	AI	0/1	none	Disable/enable internal AM

Table 2-8. IEEE-488 Commands (cont)

DC coupled AM	SP	60/61	none	Disable/enable DC coupled AM
DC coupled AM	DA	0/1	none	Alternate programming command for disable/enable DC coupled AM operation
Program FM	FM	float	GZ MZ KZ HZ RD	Program FM deviation in units of: gigahertz megahertz kilohertz hertz radians
External FM	FE	0/1	none	Disable/enable external FM
Internal FM	FI	0/1	none	Disable/enable internal FM
Program Mod Freq	MR	0/1	none	Program modulation frequency to 400 Hz/1000 Hz.
Program Mod Freq	MF	float	GZ MZ KZ HZ	Program modulation frequency in units of: gigahertz megahertz kilohertz hertz
External Pulse	PE	0/1		Disable/enable external pulse modulation
Internal Pulse	SP	40/41		Disable/enable internal pulse modulation
Internal Pulse	PI	0/1		Alternate programming command for disable/enable internal pulse modulation operation
MONITOR COMMANDS				
Input Bit	IB	none	BIT Designator	Respond with the value of the designated hardware bit.
Output Bit	OB	0/1	BIT Designator	Set the designated hardware bit to 0 or 1.
Output Dac	OD	int	DAC Designator	Set the value of the designated hardware DAC to the value specified by int.
Read Byte	RB	int	none	Read the value of the addressed byte. The Generator responds with an unsigned integer.
Read Word	RW	int	none	Read the value of the addressed word. The Generator responds with an unsigned integer.

Table 2-8. IEEE-488 Commands (cont)

Define Write Address	DW	int	none	Defines the address to be used by the write byte/word commands.
Write Byte	WB	int	none	Write int into the address specified with the define write address command.
Write Word	WW	int	none	Write int into the address specified with the define write address command.
Read Attenuation	XA	none	none	Read the current attenuation. The Generator responds with an unsigned integer.
Write Attenuation	XB	none	none	Change attenuation to 6dB times the unsigned integer. The integer can be 0 to 23.
Set Frequency Direct	XD	float	GZ MZ KZ HZ	Set the frequency hardware directly to the specified synthesizer frequency.
RF Output	XR	0/1	none	"XR0" programs all attenuation. "XR1" restores attenuation to its previous state.
RF ON/OFF ENTRY				
RF Output	RO	0/1	none	Turn RF output off/on.
SPECIAL FUNCTION ENTRY				
Special Functions	SP	00 02 03 04 07/08 09 10 11 12/13 14 15 16 17 20/21 30/31 40/41 50 51 52 60/61 70 71 72 75 76 77-79		Clears all special functions Initiates self test Display check Key check Set/reset SRQ Display S/W rev and instr ID Display IEEE-488 address Display self-test results Turn on/off display Initialize memory Latch test Display option loading Initiates self test with RF on Disable/enable relative freq Disable/enable relative ampl Disable/enable internal pulse Select dBm ampl display units Select dBmV ampl display units Select dBuV ampl display units Disable/enable DC AM Medium key repeat rate Fast key repeat rate Slow key repeat rate Display COMP memory status Repair COMP memory errors Copy MEC PROM data

Table 2-8. IEEE-488 Commands (cont)

		80 81 82 83-86 90/91 95-98		Enable all level correction Disable all level correction Disable attenuator correction Program alternate 24dB attens Disable/enable ampl fixed-rng Local COMP procedures
SRQ COMMANDS				
Interrogate SRQ Mask	IM	none	none	Interrogate the SRQ mask. The Generator responds with the decimal value of the SRQ mask.
Set SRQ	SM	int	none	The SRQ mask is set to int.
Local Operation Alert Mode	XF	0/1	none	Disable/enable a mode to set SRQ each time a Local entry is made. This SRQ is enabled by setting the front panel bit in the SRQ mask.
STEP ENTRY				
Program FREQ STEP Size	FS	float	GZ MZ KZ HZ	Program frequency step size in units of: gigahertz megahertz kilohertz hertz
Program AMPL STEP Size	LS	float	V MV UV NV DB	Program amplitude step size in units of: volts millivolts microvolts nanovolts dB
Program AM STEP Size	PS	float	PC	Program AM step size in percent.
Program FM STEP Size	DS	float	GZ MZ KZ HZ RD	Program FM step size in units of: gigahertz megahertz kilohertz hertz radians
Step Up/Down	SU/SD	none	none	Step the currently selected step function up/down one step.
Step Up/Down Frequency	FU/FD	none	none	Change the current step function to frequency and step frequency up/down one step.
Step Up/Down Amplitude	LU/LD	none	none	Change the current step function to amplitude and step amplitude up/down one step.

Table 2-8. IEEE-488 Commands (cont)

Step Up/Down AM	PU/PD	none	none	Change the current step function to AM and step AM up/down one step.
Step Up/Down FM	DU/DD	none	none	Change the current step function to FM and step FM up/down one step.
TRIGGER COMMANDS				
Configure Trigger	CT	string	none	Configures the trigger. Each time a trigger command or a group execute trigger interface message is received, the Generator executes the string of commands. The string record must end with a record terminator.
Trigger	TR	none	none	Trigger command. Equivalent to the group execute interface message. Upon processing the trigger command, the Generator executes the string, which has been preprogrammed with the configure trigger command.

More details about the commands can be found in two places. Commands that are available from the front panel are described earlier in this section (Local and Remote Operation). Those commands that are only available from the IEEE-488 Interface are described in the Command Descriptions paragraphs later in this section.

Table 2-7 is an index for the IEEE-488 Commands used in Table 2-8. This index is a list of the command headers according to function. Table 2-8 lists all the remote commands that are recognized by the Generator. The commands are listed alphabetically by function.

2-38. Programming Examples

The following three examples show how to use the IEEE-488 bus and how to use a variety of controllers to program the Generator. In the first example, a Fluke 1722A Controller is used to program the Generator. In the second example, two Generators are configured to track each other in frequency. In the third example, a 1722A is used to program the Generator with the frequency step up controlled by the trigger command.

2-39. PROGRAMMING EXAMPLE 1

Use the following procedure to program the Generator with a Fluke 1722A Instrument Controller to this state:

- Frequency 210 MHz
- Amplitude 6 dBm
- Modulation Freq. 1000 Hz
- FM 5 kHz
- Internal FM ON
- AM 15%
- External AM ON

1. Connect the Generator to the controller with an IEEE-488 cable.
2. Set the address switch of the Generator as follows (as viewed from the rear of the instrument):

00000010

3. Enter the following program into the controller:

```

1      ! Fluke 1722A BASIC program to control a 6062A.
2      ! The Address of the 6062A is 2.
3      A% = 2%
10     ! Clear the 6062A so that it is in a known state.
15     INIT PORT 0
20     REMOTE @A% \ CLEAR @A%
100    ! SET THE 6062A.
110    PRINT @A%, "FR210MZ, AP6DB, MR1, FM5KZ, FI1, AM15PC, AE1"
999    END
    
```

4. Run the program by typing on the controller "RUN (RETURN)".

2-40. PROGRAMMING EXAMPLE 2

The 6062A Synthesized RF Signal Generator can be connected to another signal generator in a master-slave configuration. In the following example, two generators are configured to track each other in frequency. This configuration may be used to track frequency, amplitude, AM, or FM.

1. Connect two signal generators together with an IEEE-488 cable.
2. Set the rear panel address switch of the first generator (talker) as follows:

00100000

Cycle the power of the first generator so the software will read the talk only switch.

3. Set the rear panel address switch of the second generator (listener) as follows:

01000000

Cycle the power of the second generator so the software will read the listen only switch.

4. Manually program the talker generator as follows:

FUNCTION	VALUE	KEY SEQUENCE
Frequency	210 MHz	[FREQ] [2] [1] [0] [MHz V]
Step Function	Frequency	[FREQ] [STEP]
Frequency Step	1.25 kHz	[1] [.] [2] [5] [kHz mV]

5. Manually program the listener generator as follows:

FUNCTION	VALUE	KEY SEQUENCE
Frequency	195 MHz	[FREQ] [1] [9] [5] [MHz V]
Step Function	Frequency	[FREQ] [STEP]
Frequency Step	1.25 kHz	[1] [.] [2] [5] [kHz mV]

6. On the talker generator, press the [↑] STEP or [↓] STEP keys. Each time the key is pressed, the frequency of both generators increases or decreases by 1.25 kHz (the Frequency Step) at frequencies 15 MHz apart.

Different functions on each generator can be programmed to track in the master-slave configuration. In other words, while the master generator can be programmed to step increase 25 kHz FM, the slave generator can be programmed to step 25% AM.

NOTE

To use the step feature for other functions, change the step function on the generators to the desired functions.

2-41. PROGRAMMING EXAMPLE 3

In the following example, the Generator is programmed by a Fluke 1722A Instrument Controller (via the IEEE-488 bus) to the same state as in Programming Example 1. Additionally, the frequency step size is set to 1.25 kHz, and the trigger buffer is programmed to execute the step up command when the trigger command is received. The SRQ mask of the Generator is set to generate an SRQ when the RF output has settled and the Generator is ready for more input from the bus.

The program then enters a loop where it waits for the ready SRQ, sends the GET (group execute trigger) interface message to step up the frequency, and waits again. At this time, do the following:

1. Connect the Generator to the controller with an IEEE-488 cable.
2. Set the rear panel address switch of the Generator as follows:

00000111

3. Enter the following program into the controller:

```

1  ! Fluke 1722A BASIC program to control a 6062A.
2  ! The address of the 6062A is 7.
3  AZ = 7
10 ! Clear the 6062A so that it is in a known state.
15 INIT PORT 0
20 REMOTE @AZ \ CLEAR @AZ
100 ! Set the 6062A.
110 PRINT @AZ, "FR210MZ,AP0DB,MR1,FM5KZ,F11,AM15PC,AE1"
120 ! Set the frequency step, output valid mode,
121 ! and configure the trigger buffer.
130 PRINT @AZ, "FS1.25KZ,VM1,CTSU"
140 ! Set the SRQ mask to enable "output valid" SRQ
150 PRINT @AZ, "SM16"
160 ! Wait for above commands to finish processing
170 WAIT 1000 \ SX = SPL (AZ)
180 ! Trigger the first step up
190 TRIG @AZ
300 ! Wait for SRQ
310 ON SRQ GOTO 800
320 WAIT FOR SRQ
800 OFF SRQ
810 ! Check the serial poll response
820 SZ = SPL(AZ)
830 IF (SZ AND 64Z+16Z) (> 80Z) THEN PRINT sz;" Bad Serial Poll Response"
840 ! Trigger the next step up
850 TRIG @AZ
860 ! Resume operation-- waiting for next SRQ
870 RESUME 300
999 END

```

4. Run the program by typing on the controller "RUN <RETURN>".

2-42. IEEE-488 Interface Functions

The Generator implements a subset of IEEE-488 Interface functions defined by the IEEE Standard 488-1978. Table 2-9 summarizes the IEEE-488 Interface functions implemented.

2-43. Address Mode

In the address mode, the Generator may be operated from local (using the front panel keys) or from remote (using the IEEE-488 Interface). The following paragraphs describe the operation of the Generator in both states and transitions between the states.

The available IEEE-488 messages and their descriptions for the address mode of operation are presented in Table 2-10.

2-44. LOCAL OPERATION

The Generator powers up in the local mode. When in local mode, the following conditions are present:

The front panel indicator REM, is not lit.

Device trigger (GET), device clear (DCL), and selected device clear (SDC) interface messages are ignored.

All device-dependent messages are ignored.

If the data output was requested while the Generator was in the remote mode, the data output of a talker may be sent.

2-45. GOING FROM LOCAL TO REMOTE

The Generator switches from local to remote when the "my listen address message" (MLA) is received, and the Remote Enable (REN) signal is true.

2-46. REMOTE OPERATION

When in the remote mode, the following conditions are present:

The front panel REM indicator is lit.

Device trigger (GET), device clear (DCL), and selected device clear (SDC) interface messages are processed.

All device-dependent messages are processed during the remote mode.

Table 2-9. IEEE-488 Interface Function List

FUNCTION	DESCRIPTION
SH1	Complete source handshake capability
AH1	Complete acceptor handshake capability
T5	Basic talker, Talk only, Serial poll, Unaddressed if MLA
TE0	No extended talker capability
L3	Basic listener, Listen only, Unaddressed if MTA
LE0	No extended listener capability
SR1	Complete service request capability
RL1	Complete remote/local capability
PP0	No parallel poll capability
DC1	Complete device clear capability
DT1	Complete device trigger capability
CO	No controller capability
E1	Open-collector drivers

Table 2-10. IEEE-488 Address Mode Message Descriptions

MESSAGE	DESCRIPTION
<p>pon Power-On</p> <p>Talker Operation</p> <p>Listener Operation</p> <p>Service Request Operation</p>	<p>When powered up, the Generator generates a Power-On message (pon) and clears its output buffer. The Generator is not addressed to talk when powered up.</p> <p>The Generator is not addressed to listen when the power is turned on.</p> <p>The state of the Service Request (SRQ) signal on pon is determined by the SRQ mask. The SRQ mask is the same as when the power was removed. Therefore, if the SRQ mask enables the power on, output valid, or ready SRQs, the SRQ signal will be true during pon.</p>
<p>MTA My Talk Address</p> <p>Talker Operation</p> <p>Listener Operation</p>	<p>The Generator is addressed to talk upon receipt of the MTA message. The front panel ADDR indicator is lit while the Generator is addressed to talk.</p> <p>The Generator unlistens when the MTA message is received.</p>
<p>MLA My Listen Address</p> <p>Talker Operation</p> <p>Listener Operation</p>	<p>The Generator untalks when the MLA message is received.</p> <p>The Generator is addressed to listen when the MLA message is received. The front panel ADDR indicator of the Generator is lit while the Generator is addressed to listen.</p>
<p>Data</p> <p>Talker Operation</p> <p>Listener Operation</p>	<p>The Generator sends data to the IEEE-488 bus only when requested by a programming data message. Message formats are described in the Command Description paragraphs. An End of Record (EOR) character is sent with EOI asserted following all outputs. The EOR character is either a carriage return or a line feed, depending on the setting of the terminator mode. The parity bit is always zero. Multiple output requests are buffered until the buffer is full. Processing of programming data messages is stopped until the buffer is no longer full. The buffer can be cleared with the Clear Buffer command ("CB"). The buffer is also cleared on power up (pon), with a Clear Command ("CL"), or with a Device Clear interface message (DCL or SDC).</p> <p>Command syntax, error processing, and input buffer overflow are described in the paragraphs on Command Processing. Refer to Table 2-8 for a list of IEEE-488 commands that are recognized by the Generator.</p>
<p>IFC Interface Clear</p> <p>Talker Operation</p>	<p>The Generator untalks and unlistens when the IFC message is received.</p>

Table 2-10. IEEE-488 Address Mode Message Descriptions (cont)

MESSAGE	DESCRIPTION
<p>Listener Operation</p>	<p>The Generator unlistens and untalks when the IFC message is received.</p>
<p>OTA Other Talk Address</p>	
<p>Talker Operation</p>	<p>The Generator untalks when the OTA message is received.</p>
<p>SPE Serial Poll Enable</p>	
<p>Talker Operation</p>	<p>After receiving the SPE message, the Generator responds with the serial poll status byte, if addressed to talk.</p>
<p>SPD Serial Poll Disable</p>	
<p>Talker Operation</p>	<p>After receiving the SPD message, the Generator resumes normal talk operation.</p>
<p>ULA Unlisten Address</p>	
<p>Listener Operation</p>	<p>The Generator unlistens when the ULA message is received.</p>
<p>RSV Request Service</p>	
<p>Service Operation</p>	<p>The front panel SRQ indicator is lit when the rsv message is sent. The Generator may request service for several reasons. Each reason for service request can be individually masked with the set mask command ("SM"). The service request mask can be interrogated with the interrogate mask command ("IM").</p>
<p>DCL Device Clear</p>	
<p>Clear Operation</p>	<p>The DCL message is ignored when in local. When the DCL message is received (during remote operation) the Generator is cleared. Any characters in the input buffer are cleared followed by the same operation as the clear command ("CL"). The operation of the DCL message is identical to the operation of the selected device clear (SDC) message. The cleared state of the Generator is described in the paragraphs on Power-On Conditions.</p>
<p>SDC Selected Device Clear</p>	
<p>Clear Operation</p>	<p>The SDC message is ignored during local operation. When the SDC message is received (during remote operation), the Generator is cleared. Any characters in the input buffer are cleared followed by the same operation as the clear command ("CL"). The operation of the SDC message is identical to the operation of the device clear (DCL) message. The cleared state of the Generator is described in the paragraphs on Power-On Conditions.</p>

Table 2-10. IEEE-488 Address Mode Message Descriptions (cont)

MESSAGE	DESCRIPTION
<p>GET Group Execute Trigger</p> <p>Trigger Operation</p> <p>Undefined IEEE-488 Commands</p>	<p>The GET message is ignored during Local operation. When the GET message is received (during remote operation), the Generator executes a command string that has been preprogrammed with the Configure Trigger command ("CT"). The operation of the GET message is identical to the operation of the Trigger ("TR") command.</p> <p>All undefined IEEE-488 commands are acknowledged by the Generator handshake sequence, but no action is taken.</p>

2-47. GOING FROM REMOTE TO LOCAL

The Generator switches from remote to local mode in one of the following ways: The IEEE-488 Go To Local (GTL) message is received, the remote enable signal REN is false, or a Return To Local (rtl) message is generated by pressing the front panel [CLR|LCL] key (if the Generator is not in the local lockout mode).

The Generator enters the local lockout mode when the Local Lockout message (LLO) is received. The Generator exits the local lockout mode to the local mode when REN is false.

When switching from remote to local, unprocessed commands in the input buffer are processed until the input buffer is cleared or a front panel entry is made. Switching to local has no effect on the contents of the output buffer.

2-48. Talk-Only Mode

Figure 2-6 shows two generators connected together with the IEEE-488 Bus.

To select the talk-only mode, set the TALK ONLY address switch to 1 (up). If the TALK-ONLY address switch and the LISTEN-ONLY address switch are set to 1, the talk-only mode is selected.

In the talk-only mode, the listener, remote/local, service request, device clear, and device trigger interface functions do not apply.

If the talk-only mode is selected, the Generator is always addressed to talk and the front panel ADDR indicator is always lit. The Step Up ("SU") or Step Down ("SD") message is sent when the [↑] STEP or [↓] STEP front panel keys are pressed. This output is not buffered, and if no listener is connected to the IEEE-488 Interface, no output will be sent. A carriage return followed by line feed (with the EOI signal true) are always sent as the end of record.

2-49. Listen-Only Mode

To select the listen-only mode, set the LISTEN ONLY address switch to 1 (up). If the talk-only address switch and the listen-only address switch are set to 1, the talk-only mode is selected.

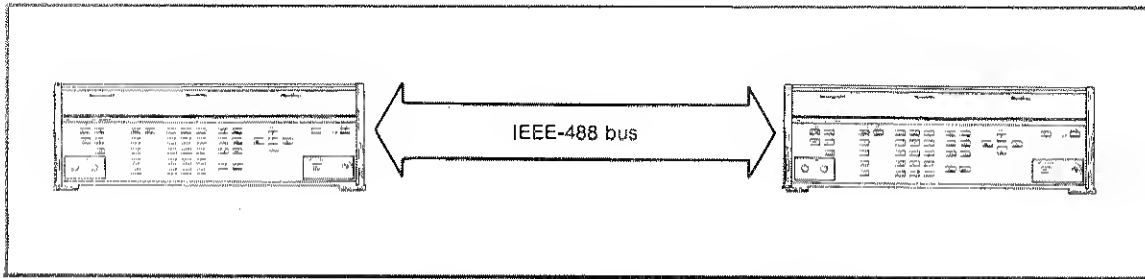

Figure 2-6. 6062A IEEE-488 Bus Connected to a 6062A IEEE-488 Bus

If the listen-only mode is selected, the Generator is always addressed to listen, and the front panel ADDR indicator is always lit. The Generator listens and responds to all data messages on the IEEE-488 Interface. The response to data messages is the same as in the addressed mode of operation except that requests for talker output are ignored.

In the listen-only mode, the talker, remote/local, service request, device clear, and device trigger interface functions do not apply.

2-50. Command Syntax

The Generator IEEE-488 bus commands alphabet consists of the letters A through Z (upper and lower case letters are treated equally), digits 0 through 9, and the following special characters:

@ . , ; + - CR LF

Spaces, tabs characters, and the parity bit are ignored.

The IEEE-488 commands for the Generator consist of the following three parts:

Header
 Numeric
 Suffix

The header is always required, but the numeric and suffix may be optional. This rule gives the following four possible combinations:

<HEADER>
 <HEADER> <NUMERIC>
 <HEADER> <NUMERIC> SUFFIX)
 <HEADER> <SUFFIX>

Multiple commands may be separated with one of the end of string (EOS) characters “,” or “,”. Use of EOS characters facilitates recovery in the event of a syntax error and will also enhance readability.

2-51. COMMAND HEADER SYNTAX

The command header is a two alpha-character string. A list of the IEEE-488 command headers used on the Generator is presented in Table 2-8. The header determines the syntax of the numeric and suffix as listed in the table.

4. Trigger String

The trigger string numeric data is a string of Generator commands terminated with an EOR. The string may be up to 71 characters, not including the EOR. Commands in the string are not checked for validity until the trigger string is executed with the trigger command.

EOR is the end of record character. This character is selected with the terminator mode command. "TM0" selects the linfeed character. "TM1" selects the carriage return character. The IEEE-488 interface signal EOI asserted with any other character is also considered an end of record.

EOS is an end of string character, use either ";" or ",".

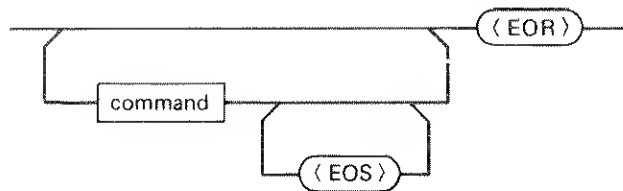

2-53. SUFFIX SYNTAX

Suffixes are always one or two alpha-characters. Certain suffixes are used to scale the numeric (the same as the front panel UNITS keys). Other suffixes mnemonically designate hardware components. The five types of suffixes are described in Table 2-11.

2-54. Command Descriptions

The following paragraphs describe the remote IEEE-488 Interface operating commands that are not accessible from the front panel of the Generator. IEEE-488 Interface commands that are accessible from the front panel of the Generator are described earlier in this section (Local and Remote Operation).

2-55. BINARY LEARN COMMANDS

Front panel setups are stored in the memory of the Generator in a packed binary format. The binary learn commands are used to transfer this binary data between an IEEE-488 controller and the Generator. These commands allow the operator to minimize the amount of programming commands needed to program the entire instrument state. The binary learn commands are:

- "LM" Learn Memory
- "LI" Learn Interface

The syntax for the Learn Memory ("LM") command is as follows:

"LM" Memory Location Code

The Generator responds to the "LM" command with a string of 66 ASCII characters followed by an (EOR) (end of record character). This string represents the front panel settings (in a packed binary format) that were stored in the memory location specified.

Table 2-11. Suffix Types

SUFFIX TYPE	SUFFIX	MNEMONIC	EQUIVALENT EXPONENT
Frequency	GZ	gigahertz	9
	MZ	megahertz	6
	KZ	kilohertz	3
	HZ	hertz	0
Amplitude	V	volts	0
	MV	millivolts	-3
	UV	microvolts	-6
	NV	nanovolts	-9
	DB	dB, dBm, dBmV, or dBuV	0
AM	PC	percent	0
FM	GZ	gigahertz	9
	MZ	megahertz	6
	KZ	kilohertz	3
	HZ	hertz	0
	RD	radians	0
DAC/BIT Designators	DAC and BIT designators are two alpha-character mnemonics that refer to hardware dacs and bits. Refer to the paragraphs on Monitor Commands for a complete list of designators.		
Learn Suffix	A Learn suffix is a string of ASCII characters that contain coded memory location contents. Refer to the paragraphs on Binary Learn Commands for decoding of the learn string.		

NOTE

The (EOR), end of record character, is sent with EOI asserted. "TM0" selects the linefeed character, and "TMI" selects the carriage return character.

Example:

IEEE-488 Command: "LM98"

Response:

"BOABAAAAPPJMAAAKAAAAAAAAAABBOKDAAAAAPECEAAABPEAAABAACEBB
AGCLKKABAEAM" EOR

Refer to Figure 2-7 for information on how to decode this learn string.

The syntax for the Learn Interface "LI" command is as follows:

"LI" Memory Location Code: Learn String

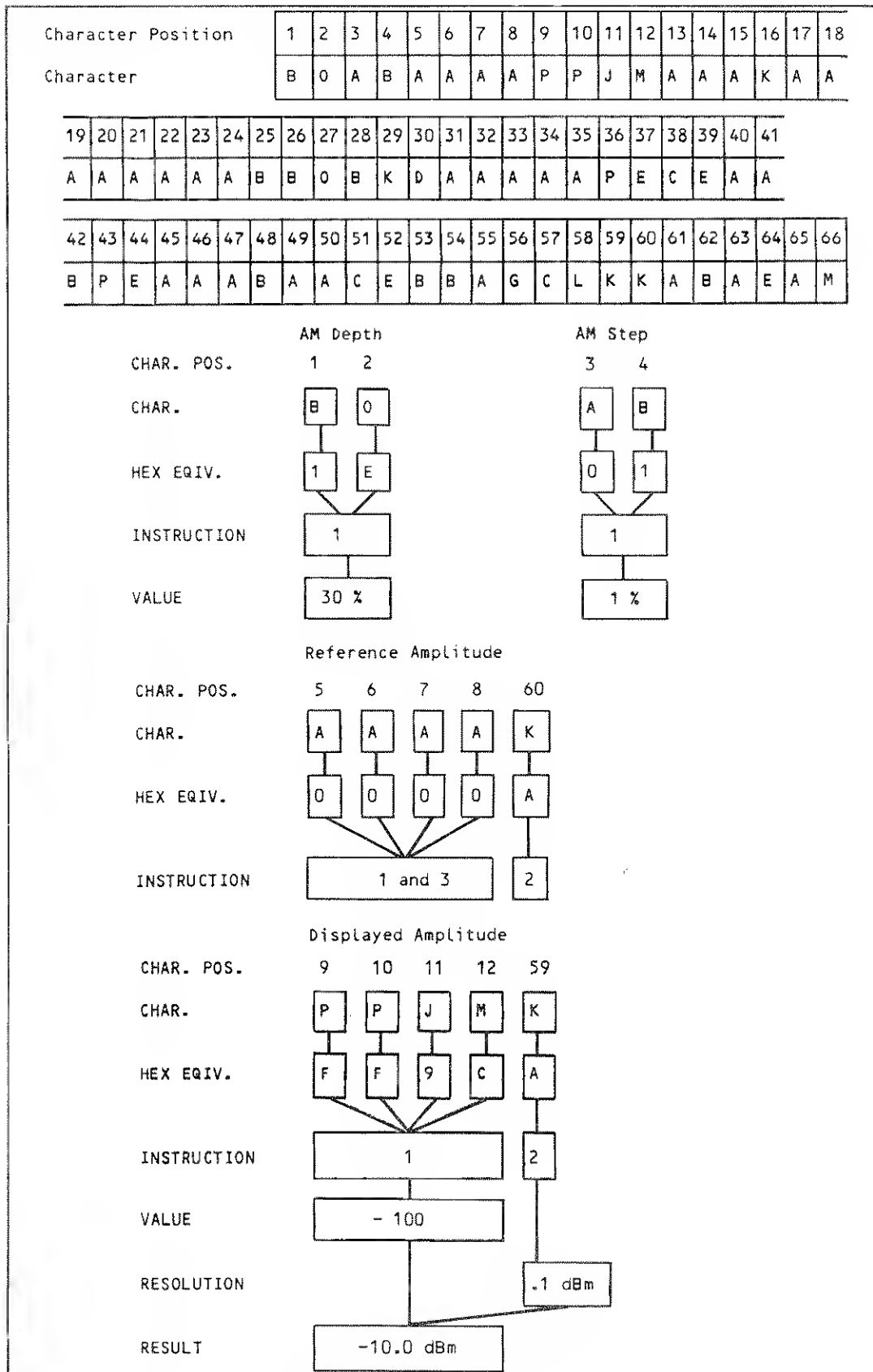

Figure 2-7. Learn String Example

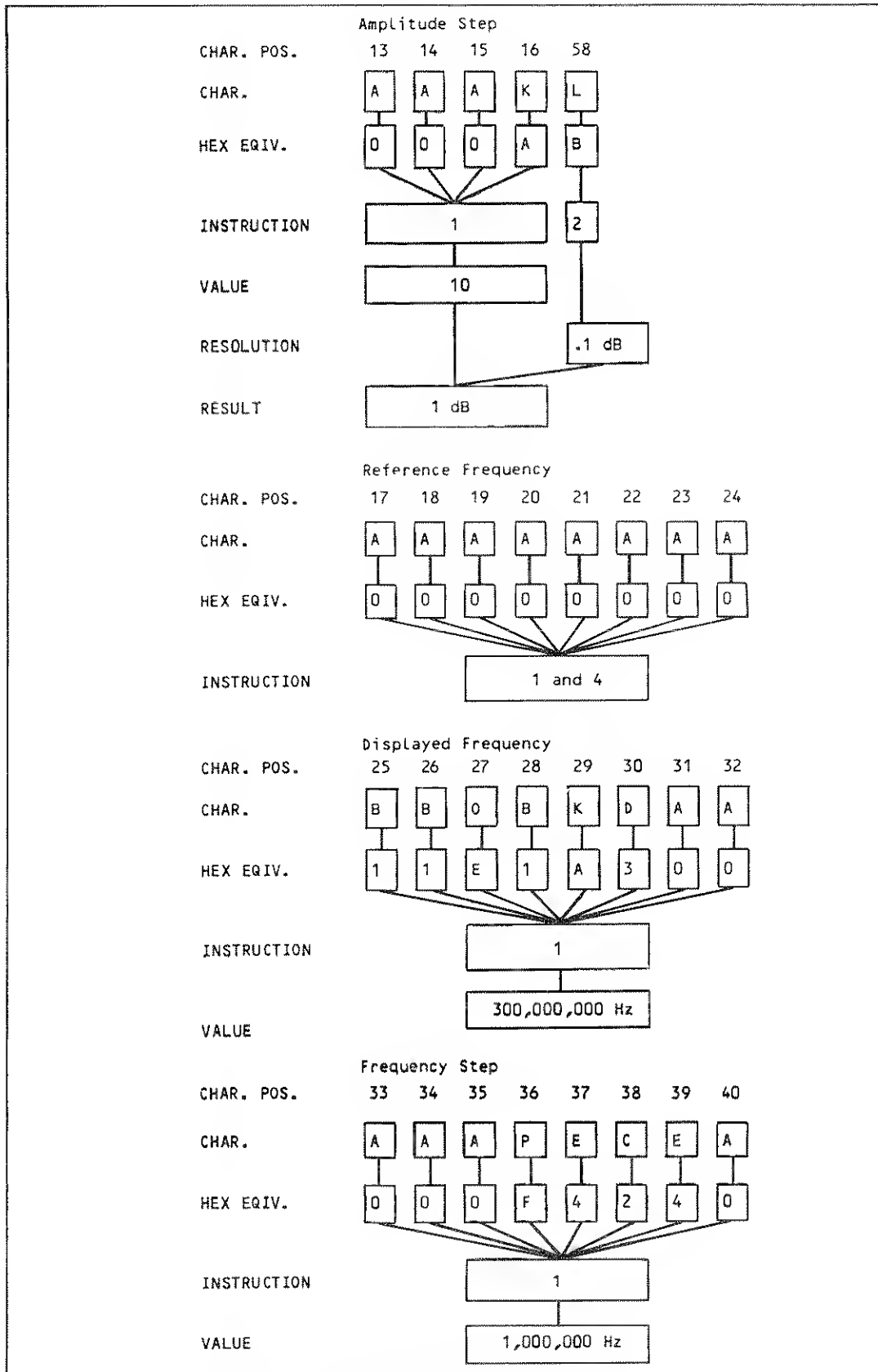

Figure 2-7. Learn String Example (cont)

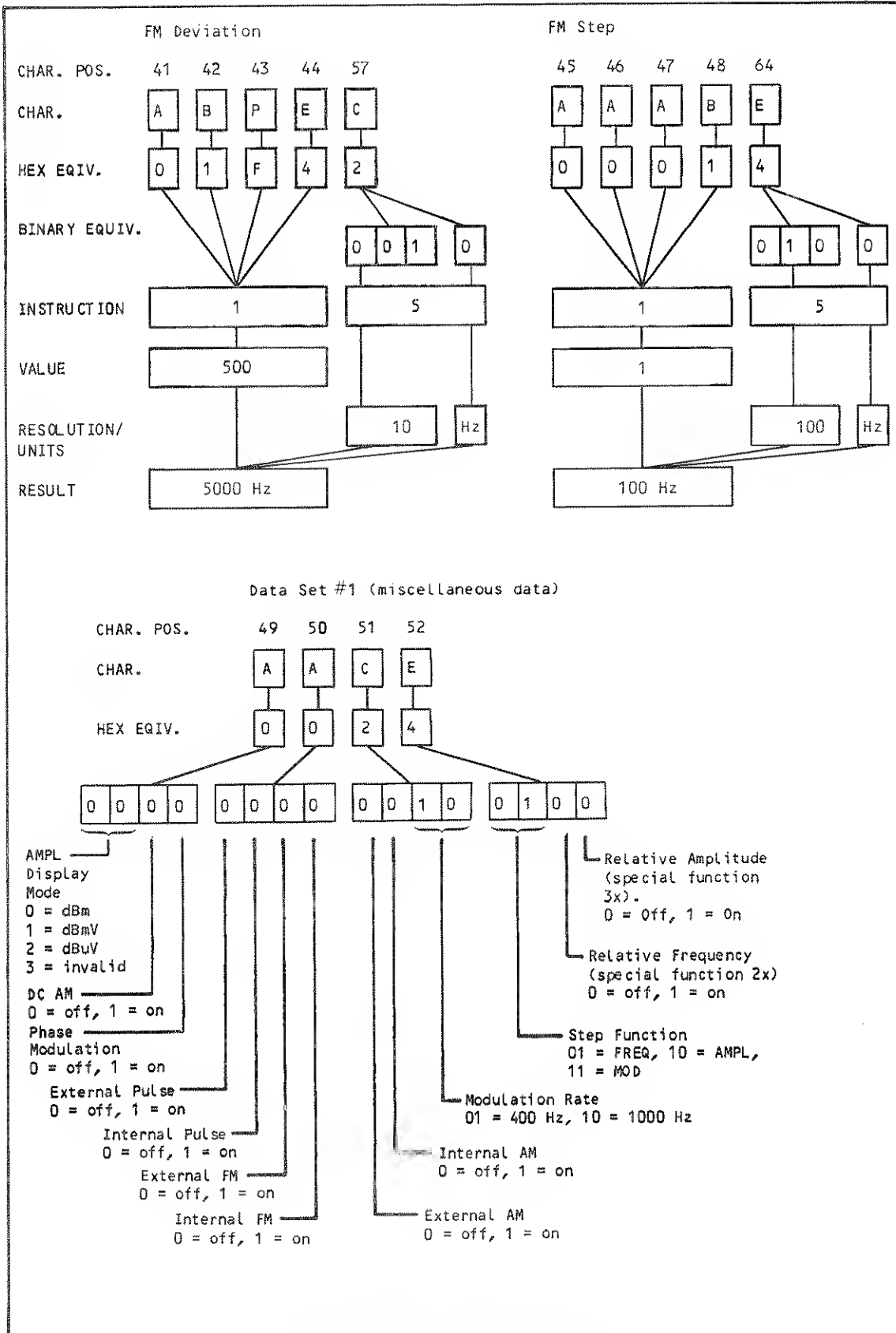

Figure 2-7. Learn String Example (cont)

INSTALLATION AND OPERATION

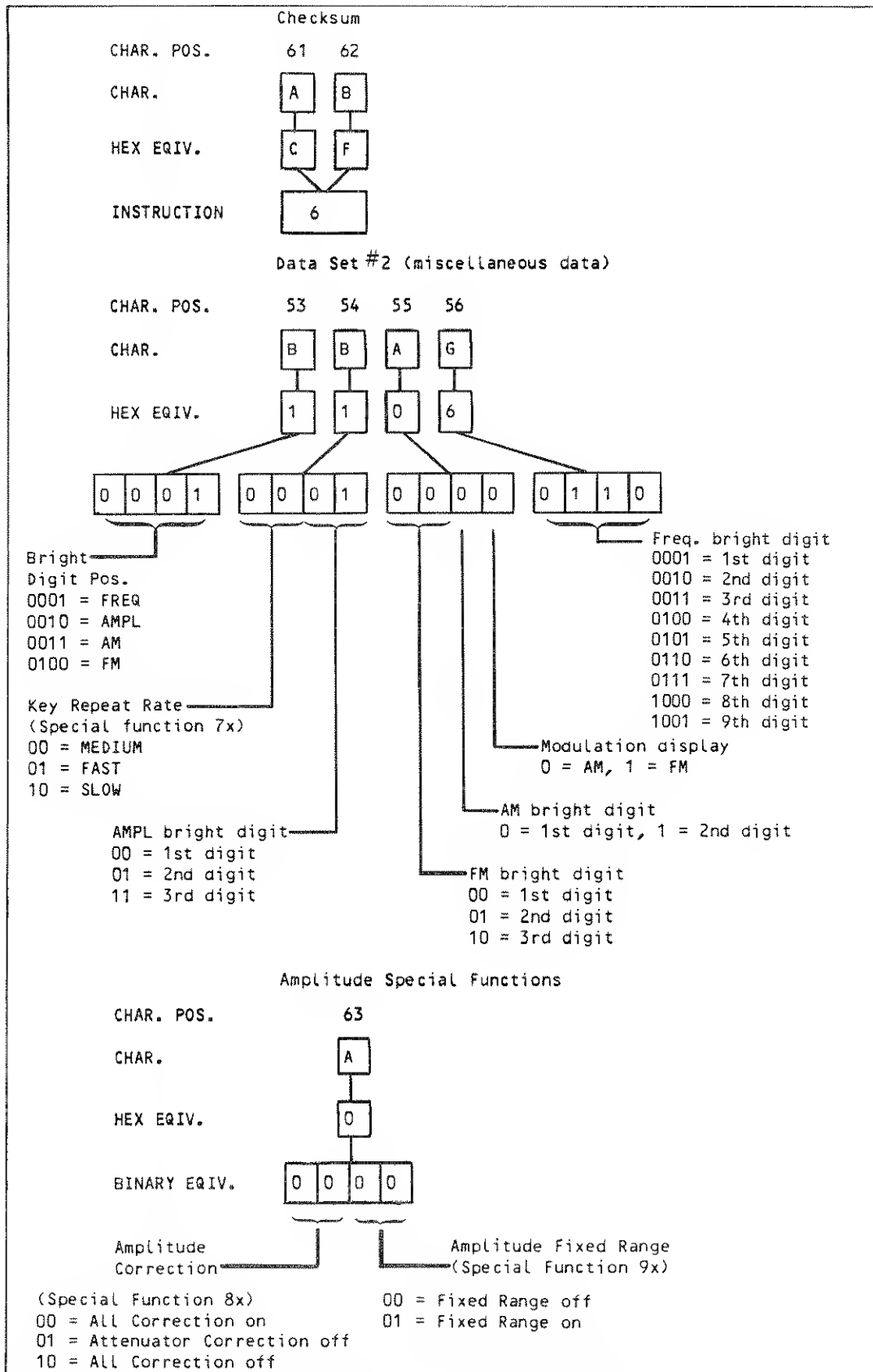

Figure 2-7. Learn String Example (cont)

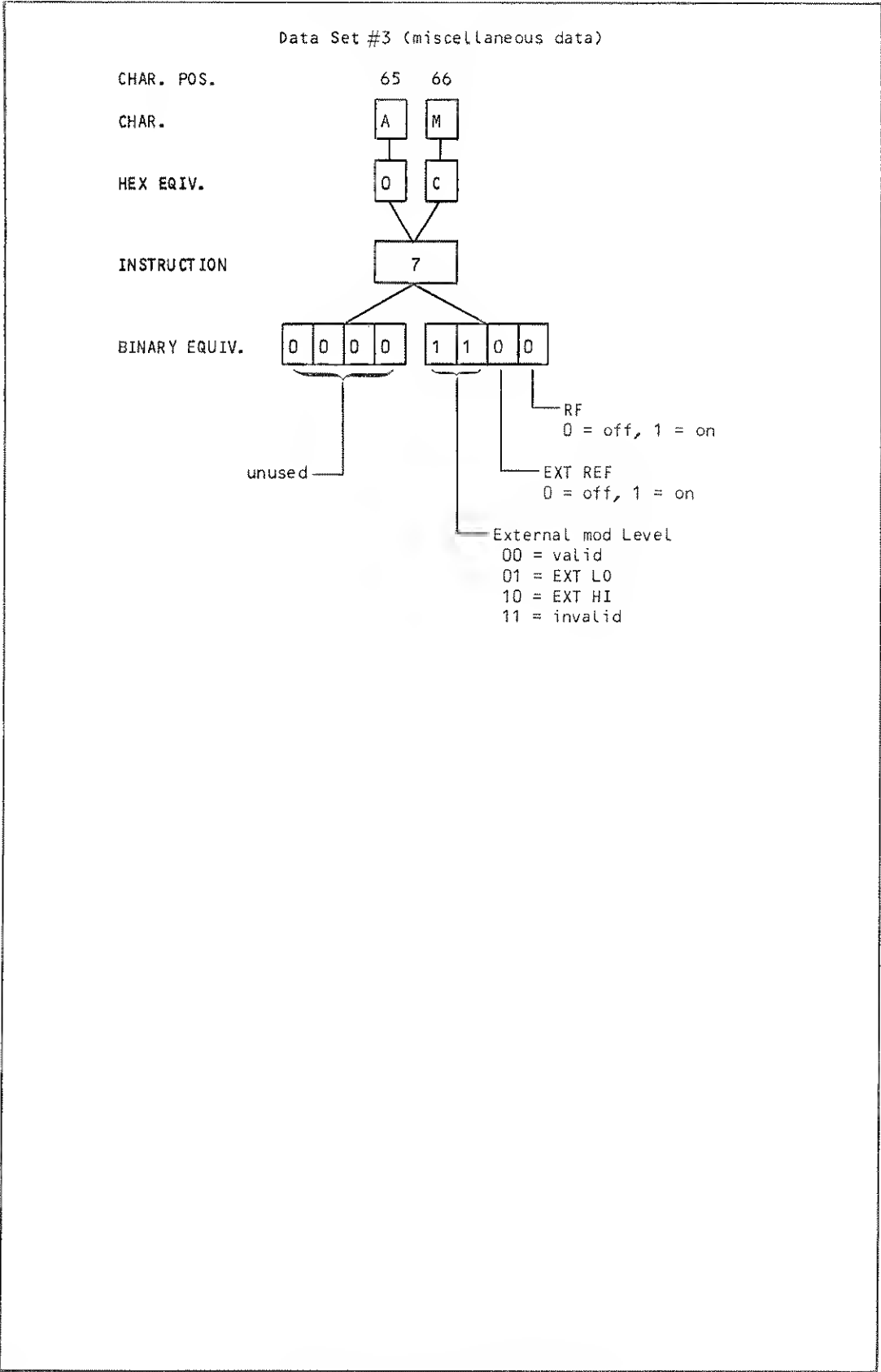

Figure 2-7. Learn String Example (cont)

INSTALLATION AND OPERATION

The Generator stores the learn string in the memory location designated by the memory location code. If the memory location specified is 99, the instrument is programmed to the data sent in the learn string.

Example:

To program the Generator to the Instrument Preset State:

“LI99BOABAAAAPPJMAAAKAAAAAAAAABBOKDAAAAAPECEAABPEAAABAAC
EBBAGCLKKABAEAM”

Note that the binary learn string in this example is the same as the learn string returned from memory location 98, which contains a record of the Instrument Preset State.

Instructions:

1. Convert the hexadecimal number to a signed decimal number as follows:
 - a. Multiply the most significant hexadecimal digit by 16.
 - b. Add the next significant digit to the value obtained in step a.
 - c. Multiply the sum of step b by 16, and add in the next hexadecimal digit until the least significant hexadecimal digit has been added.

NOTE

If the hexadecimal number started with an 8 through F, the number is negative. Perform step d for negative numbers.

- d. Subtract 16 from the number raised to the power of the number of digits.

Example of Instruction 1:

To convert hexadecimal number 1E:

$$(1 * 16) + 14 = 30$$

(Since the most significant digit is 1, the number is not negative.)

To convert hexadecimal number FF9C:

$$((((15 * 16) + 15) * 16) + 9) * 16 + 12 = 65436$$

(Since the most significant digit is F, the number is negative.)

Using Step d; $16^4 = 65536$, $65436 - 65536 = -100$. The signed decimal equivalent to FF9C is -100.

2. Amplitude quantities have a number and a resolution associated with them. This applies to the Displayed Amplitude, Reference Amplitude, and Amplitude Step.

Use the following procedure to identify the resolution of an amplitude quantity:

- a. If the resolution is A or B (hexadecimal), the resolution of the number is 0.1 dBm or 0.1 dB units.

Example of Instruction 2:

The Displayed Amplitude (in Figure 2-7) is -100 with a resolution of A.

- a. The actual displayed amplitude is -10.0 dBm.
 - b. If the stored resolution is 0 through 9 (hexadecimal), the amplitude quantity is in volts. To convert the number to the actual amplitude in nanovolts, multiply the amplitude number by the power of ten represented by the resolution.
 Example: An amplitude step of 12, with a resolution of 6 would be an actual amplitude step of 1,200,000 nV or 12 mV.)
3. If the Relative Amplitude mode is off, the data stored in the reference amplitude location is not used.
 4. If the Relative Frequency mode is off, the data stored in the reference frequency location is not used.
 5. FM and FM Step quantities have a number and a resolution associated with them. The resolution nibble is comprised of a 3-bit resolution value and a single bit units value. If the units value is 0, the FM quantity is in Hertz. If the units value is 1, it is a ϕ M quantity in radians.

To convert the number to the FM quantity in Hz, multiply the number by the power of ten represented by the resolution.

Example: The FM number (in this figure) is 500 with a resolution of 10 Hz. The actual FM deviation is 5000 Hz.

To convert the number to the ϕ M quantity in radians, multiply the number by the power of ten represented by the resolution, then divide the result by 1000.

Example: A deviation of 123 with a resolution of 1 and units of 1 would be a ϕ M deviation of 1.23 radians.

If the Low-Rate FM option is installed, the FM quantity adjusted by the resolution has a resolution of 0.1 Hz. The ϕ M quantity is derived exactly as it is without the option. The resolution remains the same, however, the range is reduced by a factor of 10.

6. The checksum data is calculated by adding the data in the learn string, two hexadecimal digits at a time. The total, including the checksum, should add up to a number whose least significant two hexadecimal digits are 01.
7. Only the current state of these parameters is relevant, so they are only valid when learning memory location 99. Learn strings from all other memory locations have characters 65 and 66 set to "AM". These parameters are provided as status information only and cannot be set using the learn interface command.

NOTE

The memory location code must be an unsigned integer indicating the memory location to be learned. Memory location 99 refers to the current instrument settings. Memory location 98 refers to the Instrument Preset State as listed in Table 2-3.

The characters in the learn string correspond to each Generator function. A description of how to interpret the characters in the learn string is given in Figure 2-7. Table 2-12 shows the conversion from the learn string to the hexadecimal character.

2-56. CLEAR COMMANDS

The following IEEE-488 clear commands are recognized by the Generator:

- “CB” Clear IEEE-488 input buffer
- “CE” Clear IEEE-488 rejected entry error status
- “CL” Clear instrument

The “CB” command can be used to clear the Generator output buffer. The output buffer should be cleared at the beginning of any remote program to synchronize data output. The output buffer is also cleared at power-on with the “CL” clear Generator command, or the buffer is cleared by the SDC and DCL clear interface messages.

The “CE” command can be used to explicitly clear the error status. The error status is also cleared when it is interrogated with the “IR” command, or the “CL” clear Generator command, or the SDC and DCL clear.

The “CL” command is used to clear the instrument state. The same actions are performed with the SDC and DCL clear interface messages. (In addition, the input buffer is cleared with the clear interface messages.) The following IEEE-488 commands are performed with the clear Generator command: “RC98, RO1, CE, CB, RM0, TM0, EM0, VM0, UM0, SM192, SP08, XF0, DW0, CT”⟨EOR⟩. If a Software Compensation Procedure is in progress, it is exited immediately and all measured data is discarded.

2-57. INTERFACE MODE COMMANDS

Interface mode commands are used to configure the Generator for different modes of IEEE-488 interface operation. Since the Generator knows when its RF output has settled, it can be configured to synchronize itself with the controller. This eliminates WAIT statements in the program, which are normally used to allow time for the output of the controlled device to settle. Table 2-13 lists the interface mode commands.

Table 2-12. Learn Character to Hexadecimal Conversion

LEARN CHARACTER	HEXADECIMAL EQUIVALENT	DECIMAL EQUIVALENT
A	0	0
B	1	1
C	2	2
D	3	3
E	4	4
F	5	5
G	6	6
H	7	7
I	8	8
J	9	9
K	A	10
L	B	11
M	C	12
N	D	13
O	E	14
P	F	15

Table 2-13. Interface Mode Commands

COMMAND	DESCRIPTION	COMMAND STATUS
"EM"	Error Mode	1 = on, 0 = off
"RM"	Record Mode	1 = on, 0 = off
"TM"	Select Terminator	1 = CR, 0 = LF
"UM"	Unbuffered Mode	1 = on, 0 = off
"VM"	Valid Mode	1 = on, 0 = off

The error mode selects when the IEEE-488 rejected entry status is cleared. If turned on, the error status is cleared when a new message is processed. If turned off, the status is cleared only when interrogated with the "IR" (interrogate rejected entry) command or when explicitly cleared with the "CE" (clear error command).

The record mode selects whether the message unit is a record or a command. When turned on, the message unit is a record. When turned off, the message unit is a command.

The terminator mode selects the character used as the record terminator. The terminator character is not used for command processing unless the record mode is enabled. When turned on, the record terminator CR (carriage return) is used. If turned off, the record terminator LF (line feed) is used. The record terminator character is the last character in all IEEE-488 messages sent from the Generator.

The unbuffered mode selects when messages from the IEEE-488 interface are processed. When turned on, messages are read from the IEEE-488 interface only when the microprocessor is ready to process them. In this mode, the input buffer will contain a maximum of one message. (A message may be one command or one record, depending on the setting of the record mode.) When turned off, messages are read from the IEEE-488 Interface to the input buffer of the Generator at the fastest rate. In this mode, the input buffer may contain up to 80 characters.

The valid mode selects when messages are processed by the Generator microprocessor. When the valid mode is turned on, processing of a new message is begun only after the RF output has settled and become valid. When the valid mode is turned off, a new message is processed immediately after the completion of the previous message.

The interface modes can also be programmed using the command, "@ " n (where n is an integer). The interface modes are set to the value of n, where n is the sum of the codes for the desired modes. The integer codes for the interface modes that can be programmed using the "@ " n commands are as follows:

```

Terminator Mode= 1
Record Mode     = 2
Valid Mode      = 4
Unbuffered Mode= 8
Error Mode      = 16
    
```

For example, to select the record mode and valid mode, the command is "@ " 6.

Interface Mode Example:

In this example, the RF output of the Generator is connected to a circuit that is being measured by a voltmeter. The output of the Generator must be settled before the voltmeter is given the command to make a measurement.

A Fluke 1722A program might look something like:

```
PRINT @1, "CL, TM1, RM1, VM1, UM1" ! initialize the 6060, select modes
PRINT @1, "FR100MZ, AP-25DB"      ! program the 6060
PRINT @2, "?"                      ! trigger the voltmeter
INPUT @2, "R#"                    ! get the reading
```

The entire record is transferred into the Generator before processing begins. In this example, processing begins when the record terminator CR is received. The following character (LF in this case) will not be received into the Generator until the entire record is processed and the output has settled. No wait statement is needed between setting up the Generator and taking the measurement because the Generator will not handshake the LF character until its output has settled.

NOTE

A record is a string of characters separated by <EOR>. A message is the smallest group of characters that the Generator can process when it is programmed from the IEEE-488 Interface.

NOTE

The output valid state of the Generator occurs 45 ms after any hardware has been changed.

2-58. INTERROGATE COMMANDS

Interrogate commands allow the status of the Generator to be given over the IEEE-488 Interface. These commands consist of headers only. The interrogate commands available on the IEEE-488 interface are:

- "IA" Attenuator Actuation Log
- "ID" Instrument ID
- "IE" Elapsed Time Indicator
- "II" Interface Mode Status
- "IL" Hardware UNCAL and Self-Test Error Log
- "IO" Option Loading
- "IR" IEEE-488 Rejected Entry Status
- "IS" Serial Number
- "IT" Self-Test Results
- "IU" UNCAL (uncalibrated) Status
- "IV" Software Revision Level
- "IZ" Compensation Memory Checksum Status

The "IA" command interrogates the attenuator actuation log. Each time an attenuator pad is removed from the RF path, the corresponding counter in non-volatile memory is incremented. This means that if an attenuator pad is removed then inserted, the count will only increment once. The Generator responds to the "IA" command with seven counts (one for each pad). The counts are separated by commas, and the response is terminated with the end of record character (<EOR>).

Example:

Attenuator Section	Number of Actuations
A6DBL	102
A12DBL	99
A241L	1028
A242L	9
A243L	19,092
A244L	3908
A245L	412

The response to the "IA" command will be:

```
0000000102,0000000099,0000001028,0000000009,0000019092,0000003908,
0000000412<EOR>
```

When the "ID" command is sent, the Generator responds with its instrument model number (and end of record character) as in "6062A"<EOR>.

When the "IE" command is sent, the Generator responds with the time the instrument has been in operation since it was manufactured. The time is 9 digits, a decimal point, a 10th digit and the <EOR> character. The time is in .1 hour units. For example, "000003459.3"<EOR> indicates 3459.3 hours of operation since manufacture.

The "II" command interrogates the current selection of interface modes. A 5-digit integer followed by the <EOR> character is the sum of the modes selected as follows:

```
Terminator mode= 1
Record mode    = 2
Valid mode     = 4
Unbuffered mode= 8
Error mode     = 16
```

The "IL" command interrogates the ten-entry error log in non-volatile memory. An error can be either a failed self test or an uncalibrated condition as a result of a hardware status line (UNLOKL or UNLVLL). The elapsed time since the instrument was manufactured is also logged with the error.

Each of the ten error log entries consists of an uncalibrated (uncal) code or self-test code, followed by a semicolon (";") followed by the elapsed time, followed by the end of record character (<EOR>). The format of the uncal code, self-test code, and elapsed time are identical to the response when interrogating the uncal code ("IU"), the self-test code ("IT"), and elapsed time ("IE") respectively.

In response to the IEEE-488 command interrogate error log ("IL") command, ten error log entries will be sent, with the most recent error sent first.

Example of an error log:

```
000,000,002,000;000039012.2<EOR> Self-test error (non-volatile memory failure) at
39012.2 hours since manufacture.
```

000,-000,002,000;000039012.1<EOR> Self-test error (non-volatile memory failure) and the self-test sequence was aborted as indicated by the “-”. This error occurred at 39012.1 hours since the Generator was manufactured.

000000,000000,000006;000020243.2<EOR> Amplitude became unlevelled at 20243.2 hours since manufacture (third number = 4). In addition, the peak amplitude was set to > +13 dBm as indicated by the second uncal code (third number = 2).

000000,000000,000000;000000000.0<EOR> This special code means that there are no errors. One or more of the error log entries will be this code when less than ten errors have been logged since the Generator was manufactured.

The number of characters in this response is much larger than the 80 characters in the output buffer. Therefore, if the entire response is not transferred to the IEEE-488 controller, the Generator will not be able to respond to further programming commands. Any remaining portion of the response that is not to be transferred can be cleared only by sending a device clear to the Generator.

The “IO” command interrogates the Generator for its option complement. The returned record contains three integers, separated by commas, that indicate configuration of options. For the 6062A, the first number is always 4, which indicates that the Generator being interrogated is in fact a 6062A. The two remaining numbers are the sum of the option related numbers as follows:

2nd Number

- 4 = -130 High-Stability Reference Option
- 8 = -651 Low-Rate FM Option
- 16 = -132 Medium-Stability Reference Option

3rd Number

- 2 = -830 Rear Panel RF Output, MOD Input, and Pulse MOD Input Option

For example, “4,12,2” would indicate a 6062A with Options -651, -130, and -830.

The “IR” command interrogates the Generator for rejected entry error status. (See Table 2-6 for a list of rejected entry codes.) The returned record is the sum of errors that have been detected while processing IEEE-488 commands. The status is cleared when interrogated with the “IR” command. The status can also be explicitly cleared with the “CE” command and is also cleared on the “CL” command and the clear interface messages DCL and SDC.

The “IS” command interrogates the Generator for the serial number. The serial number is an eight character ASCII string terminated with an <EOR>. The returned record is similar to the following:

“01230000” <EOR>

The “IT” command interrogates the Generator for the self-test results. The self-test results are reported in four fields. Any non-zero codes indicate that some tests have failed. Table 2-14 shows the self-test error code format. The self tests are performed at power-on and can also be initiated with special function 02. Further details of the self-test results are listed in the Section 4 of this manual.

Table 2-14. Self-Test Error Codes

MOD	FREQ	AMPL
aaa	-bbb ccc	ddd
aaa = Modulation (AM and FM) test results		
- = If displayed, indicates the self test did not complete		
bbb = Frequency test results		
ccc = Digital test results		
ddd = Amplitude test results		

The "IU" command interrogates the Generator for the UNCAL entry status. (See Table 2-5 for a list of the UNCAL Error Codes.)

The "IV" command interrogates the Generator for its current software revision level. The returned record is similar to the following:

"V1.0" (EOR).

This means that the software revision level is Version 1.0.

The "IZ" command interrogates the Generator for the compensation memory status. The status is returned as three fields similar separated by commas, to the following:

"000010,100001,000000" (EOR)

See the paragraphs on Compensation Memory Status located in Section 4D for details.

2-59. MONITOR COMMANDS

The Generator monitor commands are intended for troubleshooting and maintenance procedures. They allow the instrument hardware to be programmed to states not normally possible with the regular programming commands.

CAUTION

The output of the Generator is not guaranteed if the Generator hardware has been changed with these monitor commands.

There are three types of monitor commands: Input/Output, Read/Write, and Hardware Control. Table 2-15 lists the Input/Output types of monitor commands. Table 2-16 lists the Read/Write types of monitor commands. Table 2-17 lists the Hardware Control types of monitor commands.

2-60. SRQ COMMANDS

The Generator asserts the SRQ bus management line on the IEEE-488 Interface bus whenever the Generator requires service. The controller can then perform a serial poll to determine the need for service. The set mask command is used to designate those needs that require service. The SRQ commands are as follows:

- "SM" Set SRQ Mask
- "IM" Interrogate SRQ Mask
- "XF" Local Operation Alert Mode

Table 2-15. Input/Output Monitor Commands

COMMAND NAME	COMMAND	VALUE	DESIGNATOR NAME	LOCATION
Read Input Bit	"IB"		"EX" exrefl	A2, U11-7
			"HS" hsoptl	A2, U11-17
			"IE" iejnl	A2, U11-8
			"LF" lrfm	A2, U40-8
			"MH" mlevhi	A2, U40-13
			"ML" mlevlo	A2, U40-7
			"RO" roptl	A2, U40-17
			"RP" rppl	A2, U11-11
			"RT" rptrpl	A2, U11-14
			"SR" shrefl	A2, U40-4
			"TQ" trseql	A2, U40-3
			"UK" unlok	A2, U11-3
			"UV" unlvl	A2, U11-18
			"XA" extra-a	A2, U40-14
"XB" extra-b	A2, U40-18			
Set Output Bit	"OB"	0 or 1	"CL" clr	A2, U17-12
			"DA" dcam	A6, U13-19
			"EA" extam	A6, U13-12
			"EF" extfm	A6, U13-6
			"EP" ext pulse	A6, U13-16
			"FE" fmen	A4, U19-19
			"FP" front-panel	A2, U17-5
			"HO" haocth	A6, U9-2
			"HT" het	A6, U9-6
			"IA" intam	A6, U13-9
			"IF" intfm	A6, U13-5
			"IP" int pulse	A6, U13-15
			"LP" mid	A6, U9-5
			"MA" rmux0	A4, U32-5
			"MB" rmux1	A4, U32-2
			"MF" mf400L	A6, U13-2
			"MG" module-gate	A2, U17-15
			"MS" trmodl	A4, U32-15
			"NE" nven	A2, U17-9
			"PM" phase mod	A6, U23-12
			"RI" rinh	A4, U32-9
			"RR" rprst	A2, U17-6
			"SE" shen	A4, U32-12
			"SH" shet	A4, U32-16
			"VH" vcohl	A6, U23-9
			"VQ" vcoq	A6, U23-15
			"XA" x2L	A6, U9-19
			"XB" x2fL1	A6, U9-16
			"XC" x2fL2	A6, U9-15
			"XD" x2fL3	A6, U9-12
			"XE" x2fL4	A6, U9-9
			"XO" xoent	A4, U32-6
"YA" extra-a	A2, U17-19			
"YB" extra-b	A2, U17-2			
"YC" extra-c	A2, U17-16			
Set Output DAC	"OD" (integer value)	(DAC Location)	0-255 "AM" AM dac	A6 U19
			0-127 "AT" attenuator	A2, U27-5, 6, 9, 12, 15, 16, 19
			0-4095 "FM" FM dac	A6, U25-4 through 15
			0-7 "FR" FM range	A4, U19-12, 15, 16
			0-1023 "KN" kn dac	A4, U27-4 through 13
			0-1023 "KV" kv dac	A4, U29-4 through 13
			0-16383 "LE" level dac	A6, U21
			0-255 "TC" temp.comp.dac	A6, U19

Table 2-16. Read/Write Monitor Commands

COMMAND NAME	COMMAND SYNTAX	NOTES
Read byte	"RB" memory location	1
Read word	"RW" memory location	1
Define write address	"DW" memory location	2
Write byte	"WB" value	2
Write word	"WW" value	2

Notes

1. The Generator responds to these commands with the value of the byte or word in the memory location addressed. The memory location must be an unsigned integer. The value returned is followed by an <EOR>. If the memory location is specified in hexadecimal, then the value is returned in hexadecimal preceded by an "X".
2. The Define Write Address command specifies the write address used with the Write Byte and Write Word commands. When the Write Byte and Write Word commands are used, the specified data will be written to that write address.

Table 2-17. Hardware Control Monitor Commands

COMMAND NAME	COMMAND SYNTAX	NOTES
Read attenuation	"XA"	1
Set attenuation	"XB" integer	1
Set synthesizer frequency	"XD" floating point decimal "MZ"	2
RF on/off	"XR" "0" or "1"	3

Notes

1. The current settings of the Attenuator can be read or set. The attenuation is a number from 0 to 23 where the number specifies the multiple of 6-dB attenuation. Zero indicates no attenuation, and 23 is the maximum attenuation. Only the attenuators are changed with the "XB" command. The value of the attenuation will be output on the "XA" command as an unsigned integer followed by <EOR>.
2. The "XD" command can be used to program the Generator to the specified frequency. Only the synthesizer circuits on the Synthesizer PCB is programmed. No offset is added, no filters are programmed, no VCO compensation is calculated, and no level correction is calculated.
3. "XR0" programs all attenuation, and "XR1" restores the attenuator to its previous state.

The SRQ mask is set to the sum of the reason values listed in Table 2-18. These reason values correspond to the allowable reasons that will be requiring service. The SRQ Mask is set by the following command sequence:

"SM" Sum of Reasons

Table 2-18. SRQ Mask and Status Values

VALUE	REASON	TRUE	FALSE
1	Ready	Input buffer is empty and no commands are being processed.	Input buffer is not empty or commands are being processed.
2	Rejected Entry	IEEE-488 rejected entry; error code is not zero.	IEEE-488 rejected entry error; code is zero.
4	Uncalibrated	RF output is not calibrated. (Front panel 'UNCAL' indicator is lit.)	RF output is calibrated. (Front panel 'UNCAL' indicator is not lit.)
8	Power on	Instrument has powered up.	Special function 08.
16	Output valid	RF output is settled.	RF output is not settled.
32	Not Used		
64	RQS	SRQ mask ANDed with currently set values is not zero.	Reason for SRQ goes away or serial poll is performed.
128	Front panel	Special function 07.	Special function 08.

The Generator asserts SRQ when one of the allowed reasons becomes true. The serial poll response is the sum of those values for reasons that are currently true, independent of the setting of the SRQ mask. For example, if the rejected entry SRQ is enabled with "SM2" and a rejected entry occurs, the serial poll response will indicate that the Generator generated the SRQ (value of 64) and that a rejected entry occurred (value of 2). In addition, other values may be set. The default SRQ mask is 192.

The "IM" command interrogates the current SRQ mask, and an integer is returned.

The "XF" command enables a mode that causes an SRQ to be generated any time the Generator processes an entry. In this mode, a front panel SRQ is generated (i.e., the serial poll response indicates that a front panel SRQ is the cause of the SRQ). This mode is enabled and disabled with its own command, not through the Set SRQ Mask commands (as are all other SRQs). The Alert Mode is enabled/disabled as follows:

"XF0" = Alert Mode off, "XF1" = Alert Mode on.

2-61. TRIGGER COMMANDS

The Generator has the ability to preprogram a command string of arbitrary Generator programming commands. This command string is executed whenever the trigger command "TR" or the IEEE-488 group execute trigger interface message (GET) is received. This method of programming the Generator can be used when a long string of commands is to be sent to the Generator over and over. The programming time is shortened by the time required to transmit the string of characters from the controller to the Generator.

The trigger commands are as follows:

- “CT” Configure Trigger
- “TR” Execute Trigger Buffer

The configure trigger command is followed by a string of any Generator programming commands up to 71 characters in length. The validity of the programming commands is not checked until the trigger buffer is executed. The power-on value of the trigger string is null (nothing).

The trigger command causes execution of the trigger buffer, which has been preprogrammed with the configure trigger command “CT”. The trigger buffer can also be executed by sending the IEEE-488 group execute trigger interface message (GET).

2-62. Command Processing

The following paragraphs describe how IEEE-488 commands are processed by the Generator. Command processing is a term for how commands are executed and how errors are handled.

2-63. COMMAND EXECUTION

The execution of the IEEE-488 commands depends on the selection of interface modes with one exception: if an IEEE-488 input is buffered and the buffer becomes full, command execution starts and no further input is accepted until there is room in the input buffer. For more details, refer to the paragraphs on Interface Modes.

2-64. ERROR HANDLING

The Generator detects two types of errors while processing IEEE-488 commands: syntax errors and processing errors. All errors are accumulated until the error status is interrogated or is explicitly cleared. The IEEE-488 rejected entry status is interrogated with the “IR” command. The error status is cleared with one of the following commands:

- “CE” Clear Error Command
- “CL” Clear Command
- “DCL” or “SDC” Clear Interface Messages

The error status is also cleared at power-on.

The SRQ mask can be set to assert SRQ when an error is detected. The SRQ is unasserted when the error status is cleared.

Syntax errors are commands that do not have the correct syntax for the specified header. For example, “FE5” is a syntax error because the external FM command requires a Boolean numeric field. Unrecognized headers are also syntax errors. An IEEE-488 syntax error causes all commands from the point of the error up to the next string terminator or record terminator to be ignored.

Processing errors are commands that are syntactically valid, but the requested value is outside the range of programmable values. For example, “FR99GZ” is syntactically correct, but the Generator cannot be programmed to a frequency of 99 gigahertz. Command processing continues with the next command.

2-65. Timing Data

The programming time can be broken down into four groups: transfer of commands to Generator, command parsing time, software programming time, and instrument settling time.

The total programming time depends on the selection of the interface modes. In some modes, programming steps are performed in parallel and can increase throughput. The following paragraphs give some typical timing data for the above four programming steps and describes how the interface modes affect their relative timing.

2-66. TRANSFER OF COMMANDS TO GENERATOR

The maximum rate of transfer is 0.4 to 0.5 ms per character. With most IEEE-488 controllers, all characters sent with a single output or print statement is transferred together at the maximum rate. The total time to transfer commands to the Generator is obtained by multiplying the number of characters by the rate of transfer.

2-67. COMMAND-PARSING TIME

Command-parsing time is the sum of the time required to process the header, the numeric, and the suffix. Some commands do not have numerics or suffixes. Table 2-19 gives the typical time it takes to process the different components of a command.

2-68. SOFTWARE PROGRAMMING TIME

The minimum time required to process a command is 25 ms. Most of the commands that do not program the hardware (such as storing step values) are programmed in 25 ms. Table 2-20 gives the typical time value for programming the different functions in the Generator.

2-69. INSTRUMENT-SETTLING TIME

The software-programming time typically exceeds the setting time of the RF circuitry, therefore the instrument-settling time can generally be excluded from throughput calculations. The exception is when level correction is disabled. Disabling level correction reduces the software-programming time by 10 ms but does not affect the switching time of the frequency programming circuitry. A 10 ms settling delay should be added if level correction is disabled and a settled RF output is required.

2-70. TIMING OPTIMIZATION

Timing depends upon the interface modes selected. Refer to the paragraphs on Interface Mode Commands for a complete description of the interface modes.

The transfer of commands from the IEEE-488 controller to the Generator can never be processed in parallel with anything else. The transfer of commands usually happens simultaneously, regardless of which interface mode is selected.

The parsing of the command and programming the new instrument state is performed one message unit at a time. The record mode selects a command or a record as the message unit. The record mode off ("RM0") is slower since there is extra processing between message units, and the message unit is smaller.

If the valid mode is enabled, the processing of message units is delayed until the Generator has settled from the previous message. While the RF output is typically settled before the software finishes processing the command, enabling the valid mode adds an additional delay to ensure that the output is settled before the next command is processed.

If the output of the Generator does not need to be settled between programming strings, the valid mode should be turned off to speed up processing. If the output does not need to be settled between commands, but needs to be settled between records, enable the valid mode and the record mode. The instrument processes commands within the record as fast as possible and waits for the output to settle only between records.

2-71. Power-On Conditions

The instrument parameters at power-on are listed in Table 2-21. The remote clear commands can be used to reset all parameters except the last memory location and the remote/local state.

Table 2-19. Command-Parsing Time

COMMAND COMPONENT	TIME
Header	2 ms
Boolean Numeric	1 ms
Unsigned Integer Numeric	2 ms + 1 ms per character
Floating-Point Numeric	2 ms + 1 ms per character
Trigger-String Numeric	10 ms + 0.5 ms per character
Suffix	1 to 1.5 ms
Learn-Interface Suffix	40 ms

Table 2-20. Typical Programming Time of the Generator Functions

FUNCTION	TIME (IN ms)	NOTES
Frequency	70	1, 2, 3, 4
Amplitude in Volts	60	1, 2, 4, 5
Amplitude in dBm	95	1, 2, 4, 5
AM Depth	50	2, 4
FM Deviation	35	4
Modulation Frequency	25	
Enable/Disable AM	55	2,
Enable/Disable FM	25	
Recall 98	190	6, 5
RF Output On	50	2
RF Output Off	35	
<p>Notes</p> <ol style="list-style-type: none"> 1. May take up to 5 ms longer if the relative mode is enabled. 2. Can save 10 ms if all level correction is disabled with special function 81. 3. Add 20 ms when frequency changes from greater than or equal to 245 MHz to less than 245 MHz. 4. Edits and steps may take up to 5 ms longer than the programming function directly. 5. Add 15 ms when the Attenuator settings change. 6. Recalls vary considerably depending on the stored data. Maximum is approximately 250 ms. 		

