

J. Andrew Hanlan
FERMENTED LIQUORS:

A TREATISE ON

BREWING, DISTILLING, RECTIFYING,

AND MANUFACTURING OF

SUGARS, WINES, SPIRITS,

AND ALL KNOWN LIQUORS, INCLUDING CIDER AND VINEGAR.

ALSO, HUNDREDS OF VALUABLE DIRECTIONS IN

MEDICINE, METALLURGY, PYROTECHNY,

AND THE ARTS IN GENERAL.

BY DR. LEWIS FEUCHTWANGER,

PRACTICAL AND CONSULTING CHEMIST,

148 MAIDEN LANE, NEW YORK.

With Wood-Cuts of

DISTILLING, RECTIFYING, AND VINEGAR APPARATUS.

PRICE TWO DOLLARS.

NEW YORK:

PUBLISHED BY THE AUTHOR.

1858.

KD 36674



Entered according to Act of Congress, in the year 1858,
By DR. LEWIS FRECHTWANGER,
In the Clerk's Office of the District Court of the United States for the Southern
District of New York.

R. C. VALENTINE,
STEREOTYPES AND ELECTROTYPES,
81, 83, & 85 Centre-street,
New York.

P R E F A C E .

NUMEROUS pamphlets containing recipes and guides for the distiller have of late years been promulgated ; none, however, have realized the just expectations of those men who are trafficking in fermented liquors. They searched in vain for information, but could not find it, and were disappointed in their purchases. The subject of distilling and brewing has not been treated as a science, and the author conceived the idea that such a vacancy may be supplied by his humble efforts.

He has devoted several years to the investigation of this branch of chemistry, and has spent the greater part of his life in the study of natural history and philosophy ; and he feels, therefore, that his claim for issuing a work bearing on these studies may have some weight with those persons who have long been acquainted with him.

Although he is constrained to confess that he was not fully prepared to send forth to the public a full and comprehensive treatise on such important subjects as the title-page would indicate, and would

have preferred prosecuting his experiments for a longer time, so as to be fully satisfied himself that his labors will be crowned with success, and that his contributions on the subjects treated of should give unqualified satisfaction ; yet, receiving numerous pressing letters and calls from a great many of his city and country customers,—who presumed that, being a manufacturer, importer, and dealer of the various essences, flavorings, and essential oils, he would be capable of giving at once every desired information, —and not wishing, by a refusal, to impede the progress of his business relations, he has set to work and compiled the following pages, imperfect and incomplete as they may be, which will contain many new preparations, manipulations, secrets, and drawings, that never appeared in print ; and he trusts that his present efforts may prove useful and lucrative to his friends.

The author begs to call the attention of his readers to a number of subjects which have been introduced in this treatise, and which are altogether novel and instructive ; such as the new rectifying process, and substances more effectual for the rectifying tubs ; the apparatus for converting whisky into strong vinegar, within twelve hours, at a very trifling cost ; the artificial cider, at less than half the usual price ; and the manufacture of many wines and other liquors, never before made public.

The experience of thirty years' active life in his profession, of a Practical Chemist—his desire to keep pace with the advancement of science, and to manufacture all the new productions used of late years in medicine and the arts, have given him many advantages; and he thought it advisable to communicate these stores of information to the public.

Part II. treats on Hygiene, relating to health, enumerating the most common diseases, their remedies, and medical cases, for family use; also describing hundreds of nostrums got up by empirics for the sake of gain.

Part III. is the Polytechnic and concluding part. It comprises many new alloys employed in metallurgy, chemicals used in ambrotyping, artificial guano or fertilizers, artificial gum arabic, and a description of all the artificial gems, and how to imitate them; on bleaching of shellac and wax; on cleaning, clearing, and cleansing mixtures; on cements, from that for filling cavities of teeth to that of an iron retort; on colored fires, a part of pyrotechnics, giving many new mixtures for colors which are cheap; many new prescriptions in cosmetics, such as soaps, Cologne and other perfumed essences; dentifrices, hair-dyes and invigorators; on ink and varnishes, and many other preparations highly useful to the druggist, chemist, perfumer, and the mechanic. All these prescriptions will be of considerable benefit;

and we trust that many grateful acknowledgments await us from those who will amass fortunes by the information acquired through our advice.

The books which the author has, for the compilation of the following pages, consulted, are Johnson's Chemistry of Common Life, Booth's Encyclopedia, Wright's Cordialanica, and Percy's Lexicon.

THE AUTHOR.

NEW YORK, *March*, 1858.

C O N T E N T S .

	PAGE
PREFACE	8
CHAPTER I.—FERMENTATION EXPLAINED.....	18
Varieties of Fermentation: Vinous, acetous, putrefactive, lactic, and butyric—Ferment and gluten, vegetable albumen—Sugar the base of fermentation—Various kinds of sugar: Grape, cane, manna, and milk sugars—Manufacture of sugar-cane, beet, palm, maple, and corn sugars.	
CHAPTER II.—FERMENTED LIQUORS.....	20
Atomical composition and equivalents—Starch, gluten, and diastase explained—Beer, malt, and hops—Zeolithoid, or new beer generator—Extract of malt—Alcohol contained in beer, porter, and ale—Chica, or corn beer—Bouza, or millet beer—Quarf, or rye beer—Koumiss, or milk beer—Ava, or South Sea Island beer—Beer constituents—Upper and lower fermentation—Scotch ale, Bavarian beer, Strasburg ale—Ginger beer, spruce beer, root and lager beer.	
CHAPTER III.—WINE	30
Apple wine cider and imitation cider—Grape wine, per centage of alcohol—Grape wine contains tartaric acid and œnanthio ether—Physical distinction of wines—Fining of wines—Consumption of wines.	
CHAPTER IV.—WINE BEVERAGES	38
FRUIT WINES: Apple, pear, cherry, quince, raisin, gooseberry, currant, raspberry, elderberry, and root wines—Maple, carrot, potato, palm, sugar-cane, agave, ginger, &c.	
SUGAR WINE: Columbia wine and mead.	
IMITATION WINES: Madeira, Burgundy, Medoc, Malaga, Muscat, Canary, Tokay, Port, Claret, Sherry, and Rhine.	
SPARKLING WINES: Champagne, Champagne from gooseberry, Champagne from cider.	

	PAGE
CHAPTER V.—COLORS FOR WINES	48
Sugar coloring—Table of alcohol per centage of all fermented liquors, by measure.	
CHAPTER VI.—ARDENT SPIRITS, ALCOHOL, BRANDY, AND ALL OTHER LIQUORS	51
Composition from various materials—General remarks on the various products—Fusel oil of potato identical with Cognac oil or grape oil.	
CHAPTER VII.—DISTILLATION	55
Description of Simple, Pistorius', and Dr. Gall's perfect Distilling Apparatus—Mashing process, preparation of the wort, and its fermentation—Yeast, description and manufacture of.	
CHAPTER VIII.—RECTIFYING PROCESS	64
Rectifying by bone black—by charcoal—Rectifying apparatus with and without sand.	
CHAPTER IX.—HYDROMETER	70
Meaning of proof explained—Sykes' hydrometer—Condensation of volumes of alcohol and water—Tables of contraction of alcohol and water.	
CHAPTER X.—THE HYDROMETER AND THERMOMETER ..	80
Reduction of temperature.	
CHAPTER XI.—CLEARING OF LIQUORS	83
By mixture—By age and body.	
Preparation of Sugar syrup—Lemon syrup—Fruit syrup.	
CHAPTER XII.—DIVISION OF LIQUORS	85
Rum, Arac, and Cognac—Derivation of the word Cognac—Rochelle brandy and whisky—Gin, cider, peach, cherry, plum, and cordials.	
Manufacture of arac—Cognac from oil—Cognac from essence—From extract of the grape-juice—From Brandy flavoring—Whiskies—Holland and London gins—How to clear a milky gin.	
Manufacture of Jamaica rum—Of New England rum—Peach, cider, cherry, blackberry, raspberry, plum, orange, cin-	

namon, ginger, and clove brandies—Of peppermint, kimmel, anise, and wormwood liquors—Of stomachic bitters—Extract of punch.

CORDIALS :—Manufacture of absinthe, Curaçao, Maraschino, anisette, parfait d'amour, cherry-bounce, raspberry, railroad, elixir vitæ, orange elixir, Roman punch, kirschwasser, noyeau, orgeat, and other cordials.

CHAPTER XIII.—ACETIC ACID, VINEGAR, AND QUICK VINEGAR..... 101

Composition of acetic acid—Distilled vinegar—Wood or pyroligneous acid—Apparatus for the quick vinegar process—The latest improved process—Raspberry and forty-thieves vinegar—The latter explained.

CHAPTER XIV.—ADULTERATIONS OF ALL FERMENTED LIQUORS 109

CHAPTER XV.—BAR-ROOM DRINKS OR BEVERAGES.... 110

Mint julep, grog, negus, punch, &c.

PART II.

HYGEINE, OR TREATISE ON HEALTH.

CHAPTER I.—DISEASES, REMEDIES, AND TREATMENT IN MEDICAL CASES 114

Properties of the principal medicines which are used in daily practice.

CHAPTER II.—MATERIA MEDICA, OR THE USE OF FAMILY MEDICINES, IN TABLE FORM, CONTAINING TWO HUNDRED REMEDIES..... 180

CHAPTER III.—MEDICAL CASES, THEIR SYMPTOMS AND TREATMENT; CONTAINING THE MOST IMPORTANT DISEASES AND THEIR REMEDIES, WITH 250 CASES..... 188

CHAPTER IV.—A LIST OF APPROVED HOUSE REMEDIES AND NOSTRUMS..... 147

PART III.

POLYTECHNY; OR A TREATISE ON THE VARIOUS
BRANCHES OF THE ARTS.

	PAGE
CHAPTER I.—ON METALLURGY	156
Explaining a number of new alloys and metallic compositions for writing-pens, imitation silver, imitation gold, German silver, and metallic pencils.	
CHAPTER II.—AMBROTYPE CHEMICALS	159
Explaining the apparatus, and how to prepare the chemicals for this art.	
CHAPTER III.—ON ARTIFICIAL GUANO, OR FERTILIZER ..	164
Explaining several mixtures for the purpose of fertilizing the ground, and how to test the guano. Also, how to prepare an artificial gum arabic, equal in appearance and quality to the natural gum arabic.	
CHAPTER IV.—ARTIFICIAL PRECIOUS STONES	164
How to imitate all the gems, from the diamond (the strass) to the ruby, sapphire, emerald, opal, &c.	
CHAPTER V.—MISCELLANEOUS RECEIPTS	171
Blacking for boots and harness—Bleaching of shellac, sponge, &c.—Bottle and sealing wax—Cements and pastes—including many useful preparations for stone and iron, furniture, and hydraulic cements.	
CHAPTER VI.—ON CLEANING, CLEANSING, AND CLEARING MATERIALS	177
Many simple and useful ingredients for polishing silver, brass, and furniture; also clearing mixtures for coffee, cider, and wines.	
CHAPTER VII.—ON COLORED FIRES OR PYROTECHNICS ..	179
The best prescriptions for producing fine colored fireworks, from the author's own experience.	

	PAGE
CHAPTER VIII.—ON COSMETICS	183
Comprises various branches, such as the preparation of useful soaps, as cosmetic, glycerrhine, cream, family, and detergent soap; starch polish, or linen gloss; the chemical whale oil soap; opodeldoc and transparent soaps.	
Comprises also the preparation of Cologne waters—Handkerchief perfumes—Dentifrices, such as tooth powders, tooth washes, and tooth pastes.	
On Antique, Macassar Oils, and Pomatums, for the growth of hair, complexion, and lips—On Hair Dyes, several economical and useful preparations—On Fumigating articles for sick-rooms and churches—Pastiles, liquid rouge, and smelling salts—On Hair Invigorators or Restorers, giving the best prescriptions how to prevent the hair from falling out.	
CHAPTER IX.—ON SOLDEBS AND SILVERINGS	199
CHAPTER X.—ON VARNISHES	200
How to prepare the best boiled linseed oil without any danger—White copal and mastic varnishes.	
CHAPTER XI.—ON INKS	202
Good writing, stamping, and copying inks.	
CHAPTER XII.—ON POISONS FOR DESTROYING INSECTS INFESTING HOUSES	205
Giving valuable prescriptions for preparing the celebrated Rat Destroyer, a preparation of phosphorus—A valuable powder for driving away cockroaches —Fly paper, &c., &c., &c.	

FERMENTED LIQUORS.

CHAPTER I.

§ I.

FERMENTATION.—The word fermentation means a spontaneous change, undergoing in solutions containing sugar, under certain circumstances. In the production of beer, which is the result of fermentation, the sugar is derived from the malt; in that of wine, it is from the juice of the grape; and no vegetable juice can be made to undergo the process of fermentation perfectly, if sugar is not contained in it in a considerable degree. The product of fermentation is an intoxicating liquid, called *alcohol*. The alcoholic or vinous fermentation is therefore the change of a saccharine solution, with the presence of yeast or ferment. The juice of fruits ferments spontaneously, as it incloses both the ferment and sugar. To the infusion of malted grain, ferment (yeast) is added; but, after fermentation, the quantity of yeast is increased, being formed from a substance existing in the grain. A number of substances produce their own peculiar fermentations, such as the *vinous, acetous, putrefactive, lactic, butyric, and other fermentations*. In the vinous fermentations, alcohol and carbonic acid are formed by the decomposition of the sugar contained in solution; but also a yellow or gray insoluble substance, containing a large quantity of nitrogen, is produced, which is called *ferment*, having the

power of inducing fresh fermentation in a new solution of sugar, and which has its origin from the azotized constituents of the juices called *gluten*, or *vegetable albumen*. It is certain that the *wort*, or infusion of malt, contains the azotized matter of the wort, or the gluten, and that the ferment is formed from the gluten at the same time that the transformation of the sugar is effected, in the same condition as the gluten exists in the juice of grapes. The wort ferments by the addition of yeast; but after its decomposition is completed, the quantity of ferment or yeast is found to be thirty per cent. greater than it originally was. The yeast from beer and that from wine are quite identical.

§ II.

As sugar forms the base, and the ingredient from which our brewers and distillers manufacture their liquors, it is of some importance that the reader should be made familiar with all the varieties of sugar.

The ancient world knew only the honey, grape, manna, and fruit sugars. In the present age we have added the cane, maple, beet, corn, and palm sugars. Sugar is also manufactured from potatoes and other substances rich in starch; from chickweed, sawdust, and from the milk of our cattle.

The numerous varieties of useful sugars are arranged under four heads, which are—I. The *grape sugars*; II. The *cane sugars*; III. The *manna and liquorice sugars*; and, IV. The *animal or milk sugar*.

I. The grape sugar has again five varieties, which are,—
1. Sugar of the grape; 2. Sugar of honey; 3. Sugar of fruits; 4. Sugar of potatoes, or starch sugar; and, 5. Elderberry sugar.

1. *Grape Sugar*.—The ripe grape, when dried, forms the well-known raisin. In this, when opened, are numerous whitish crystalline brittle grains, which are sweet to the taste.

This is called the grape sugar, which dissolves readily in water, and if yeast be added to the solution, soon enters into fermentation.

The result of this fermentation is a spirituous liquor resembling wine, and afterwards, by continued fermentation, an acid liquor, like sour wine or vinegar.

2. *Honey Sugars.*—Honey is formed, or naturally deposited, in the nectaries of flowers, and is then extracted from them by the working bees; this they deposit in their crop, or honey-bag, and from this receptacle disgorge it again when they return to the hive. When liquid honey is allowed to stand for a length of time, it gradually thickens and consolidates; by pressure through a linen bag, a white solid sugar, consisting of minute crystals, remains, while the semi-fluid syrup runs through it.

3. *Fruit Sugars.*—The apple, pear, plum, peach, gooseberry, currant, and cherry, contain and owe their sweetness, acquired when fully ripened, to grape sugar, and the same may readily be extracted; they are mostly, however, either dried or made wine of.

4. *Potato or Starch Sugar.*—It is a property of starch of all kinds to be insoluble in cold water, but to dissolve in boiling water, and to thicken into a jelly as it cools; but if a small quantity of oil of vitriol (sulphuric acid) be added to the water in which it is boiled, the solution gradually acquires a sweet taste, and ultimately the whole of the starch is converted into grape or honey sugar. A pound of acid, diluted with one hundred pounds of water, will convert a great many pounds of potato, wheat, or sago starch into sugar. If the acid be then separated by lime, and the liquor boiled down better, a rich syrup or a solid sugar may be obtained. Instead of sulphuric acid, we may mix with the water twelve to fifteen pounds of malt for every one hundred pounds of starch; heat for three hours to one hundred and

sixty degrees, and filter and evaporate the syrup. This sugar is much used in Europe for sweetening, for adulterating cane sugar, and for the manufacture of spirituous liquors. The French confectioners employ this syrup extensively, and brandy is distilled from it in Northern Europe.

Instead of starch, woody fibre, paper, raw cotton, flax, cotton and linen rags, and sawdust, may be transformed into sugar by digestion in diluted sulphuric acid. This operation is explained by the acid first changing the fibre into starch, and then the starch into sugar. Likewise Iceland and Irish moss and Ceylon moss, and other sea-weeds which form a jelly when boiled in water, may be converted into grape sugar, when digested in diluted sulphuric acid.

5. *Elderberry Sugar*.—The sugar obtained from the elderberry resembles likewise grape sugar, but differs somewhat in other properties.

II. The plants or fruits which possess distinctly acids, or sour juices, yield grape sugar; those which have little acid in their saps, contain for the most part cane sugar. The varieties of the sugar-cane are,—1. *The Cane*; 2. *Beet*; 3. *Palm or Date*; 4. *Maple*; 5. *Corn Sugar*.

1. *Sugar-cane or Chinese Sugar*.—The soil where the sugar-cane grows is within the torrid zone, and at low elevations; it forms, in many tropical regions, a staple part of the ordinary food: the ripe stalk of the plant is chewed and sucked, and in the markets of Manilla and Rio Janeiro, in New Orleans, and in the Sandwich and other islands of the Pacific Ocean, affords food for the inhabitants. The nutritive property of the raw juice of the sugar-cane arises from the circumstance that it contains, besides the sugar to which its sweetness is owing, a considerable proportion of gluten, as well as of those necessary mineral substances which are present in all our staple forms of vegetable food. The juice of the sugar-cane varies in composition and richness with the

variety of cane, the nature of the soil, the mode of cultivation, and the dryness of the season. Its average composition in sugar plantations, when the canes are fully ripe, is—sugar from 18-22 parts in 100, water and gluten 71 parts, woody fibre 10 parts, and saline matter 1 part.

The sugar is extracted in the following manner : the canes are cut, the leaves and tops are chopped off and left in the fields, while the under or ripe part is carried to the mill, where the ripe canes are passed between heavy iron crushing-rollers, which squeeze out the juice ; this is run into large vessels, where it is clarified by the addition of lime or bisulphide of lime. This operation has a twofold object : it removes or neutralizes the acid which rapidly forms in the fresh juice, and at the same time it combines with the gluten of the juice and carries it to the bottom. This gluten acts as a natural ferment, causing the sugar to run to acid, and it requires to be speedily removed. After being clarified in this way, and sometimes filtered, the juice is boiled down rapidly and run into wooden vessels to cool and crystallize. It is finally put in perforated casks to drain : the *raw* or *muscovada sugar* remains, and the drainings are the *molasses*. The molasses and skimmings are fermented and distilled for rum.

The cane-sugar is much sweeter than the grape sugar, and dissolves more readily in water ; for one pound of cold water dissolves three pounds of cane, and but one pound of grape sugar.

2. *Beet-root Sugar* is obtained from the sliced beet-root being squeezed out and the juice boiled down. When raw, it possesses a peculiar unpleasant flavor, but when refined it is scarcely distinguishable in any respect from that of the sugar-cane.

3. *Palm or Date Sugar*.—Most trees of the palm tribe, such as the date-palm, gomuti-tree, the sap of the cocoa-nut

tree, and wild date-palm, yield a copious supply of sweet juice when their top shoot or spadix is wounded. This palm-sugar, from whatever tree it is extracted, is exactly the same species of sugar as that yielded by the sugar-cane.

Other non-acid fruits, like the melon, chesnut, and cocoanut, contain cane sugar.

4. *Maple Sugar*.—This sugar is only prepared in the eastern section of the United States, where the maple-tree grows in abundance. It is identical with pure sugar-cane in all its properties.

5. *Maize or Indian Corn Sugar*.—The green stalks of the corn contain a sweet juice which, when boiled down, yields an agreeable variety of cane sugar.

6. *Sorghum Sugar*, extracted in China from the dhurra plant, is likewise a species of the cane sugar. It has of late been cultivated in the northern part of the United States with a satisfactory result. It promises to be at a future day a great rival to the sugar-cane.

III. *Manna and Milk Sugars*.—These sugars are less sweet than the previous ones, and do not ferment when mixed with yeast.

1. Manna of the ash-tree, chiefly cultivated in Sicily and Calabria, is from the sap of the tree, which hardens on the outside of the tree. This manna contains two kinds of sugar: one-third of its weight is gum; one-third of white crystalline sugar, called mannite; and only about ten per cent of a sugar resembling grape sugar, which ferments with yeast. It is the large quantity of gum which diminishes its sweetness.

This species of sugar is contained in many sea-weeds and mosses, also in the common celery and dandelion roots.

2. The gum-tree manna of Australia and Van Dieman's Land. This is sometimes seen to fall like a shower of snow over a large district, when the wind blows. The sweet

substance exuding from the leaves of the gum-tree, drying in daytime in the sun, is carried off at night. It is a peculiar crystallizable sugar. It is probably the same sugar which even in this country, and last year in Utah, was found on the leaves in large quantities.

3. Manna sugar from many trees, such as an oak in Kurdistan, the European larch. The manna from the pine of Mount Lebanon, is much esteemed in Syria as a remedy for affections of the chest. The Persian manna or *gen*—in Persia, Bokhara, Arabia, and Palestine—serves as food for camels, sheep, and goats. It is obtained from the camel's thorns, and is gathered by merely shaking the branches of the same.

The manna of the Old Testament is the Tamarisk manna, growing abundantly in the neighborhood of Mount Sinai. The tree called the tarfa-tree resembles much the weeping birch-tree, and the manna flows out in drops from the extremities of its slender boughs.

4. The *Orcin manna* is a sweet substance existing in certain species of lichen.

The liquorice sugar, generally known as Spanish liquorice juice, is the extract of the liquorice root. A large tree of Southern Europe. It differs in flavor from all other sugars; does not crystallize, nor does it ferment with yeast. It is used by brewers in the manufacture of porter.

5. Milk sugar. A peculiar species of sugar is contained in the milk after the curd is separated in making cheese. Its sugar remains in the whey, and is obtained in crystals by boiling the same down to a small bulk; it is hard and gritty, less soluble and less sweet than cane sugar, and it occurs in plants only in the acorn.

CHAPTER II.

§ III.

FERMENTED LIQUORS.—Beer and wine are called fermented liquors, both deriving their elements from sugar. In the production of beer, the sugar is derived from the malt; in that of wine, from the juice of the grape.

When grape sugar is dissolved in water, and a little yeast is added to the solution, it begins speedily to ferment. During this fermentation, the sugar is split up into three different substances—alcohol, water, and carbonic acid. The first two remain in the liquid, while the carbonic acid gas escapes as bubbles into the air; and chemical analysis proves, beyond a doubt, that one atom of grape sugar having the number 40—consisting of 12 parts of carbon, 14 parts of hydrogen, and 14 parts of oxygen—will contain the same number of the products just described, viz. :

2 parts of alcohol,	composed of	}	8 parts Carbon.		
		}	12 “ Hydrogen.		
		}	4 “ Oxygen.		
4 “ carbonic acid,	“	}	4 “ Carbon.		
		}	0 “ Hydrogen.		
		}	8 “ Oxygen.		
2 “ water,	“	}	0 “ Carbon.		
		}	2 “ Hydrogen.		
		}	2 “ Oxygen.		
		}	40		
1 part grape sugar.....	=	12	14	14	=
2 parts alcohol.....	=	8	12	4	
4 “ carbonic acid.....	=	4	0	8	
2 “ water.....	=	0	2	2	
		12	14	14	

The same phenomenon takes place with cane sugar; as also with starch, converted into grape sugar by the action of dilute sulphuric acid; or of a mixture of malt, if yeast is added to the sweet solution. The starch of barley and other grains is converted into grape sugar before it is removed from the seed, and is then split up as before, by means of yeast, into the same elements just described.

These grains, or cereals, consist more especially of two principal substances—starch and gluten. When moistened, and under favorable circumstances, the grains begin to sprout, and a chemical change begins to take place: the gluten is changed, among other products, into a white soluble substance called Diastase, and the starch into soluble grape sugar; hence the sweetness of the sprouted barley. This natural change in the constituents of sprouting grains forms the art of brewing.

Malt beers owe their appellation to the fact that they are manufactured, wholly or partially, from malted barley.

§ IV.—BEER.

1. *Malt*.—When barley is moistened—that is, by adding nearly its bulk of water over it—put in heaps, spread on a floor in a dark room to heat and sprout, and the germ is about to burst from the envelop of the seed, the growth is arrested by drying the grain gently on the floor of the kiln. It is then malted barley, has a sweet taste, showing that it contains sugar. Corn, oats, wheat, and rye may be converted into malt by a similar process.

2. *Beer*.—The malt is now bruised and introduced into the mash-tun, with warm water of 160° temperature, with rather more than its bulk of water; the mixture is stirred up for a few hours, then the liquor is run off, and more water added, until the malt is exhausted. These infusions are called wort, and the proper strength of the same on the

saccharometer scale is 0° at 70° temperature, or of a specific gravity 1.100.

Hops are now added to the fresh boiling wort, to one-twentieth of the weight of the employed malt. The object of the use of hops is to cover the sweetness of the liquor by an aromatic bitter, and to diminish its tendency to acidity, and also to assist in clarifying it.

The boiled liquor is run off into shallow vessels, and cooled as rapidly as possible to the best fermenting temperature, 60° Fahr.; it is then transferred to the fermenting vat, and, a sufficient quantity of yeast being added, allowed to ferment slowly for six or eight days. During this fermentation, the sugar of the wort is split up into alcohol and water, which remains in the beer, and into carbonic acid gas, which mostly escapes. The liquor becomes then clear, has lost much of its sweetness, and, diminished in its specific gravity, acquired a new flavor, and become an intoxicating liquor.

3. The *Zeolithoid*, or new Beer Generator, or grainstone, introduced since 1852 by Rietsch, in Austria, for the purpose of producing beer in the cold way, is nothing but an extract of grain (barley), and an addition of hops, and is a hard, yellow, tough mass, which does not spoil by keeping, but, when required for use, is dissolved in water, and fermented by yeast: a good beer, according to the quantity of material, is obtained in a very short time. This beer may be made on long sea-voyages, and in hot climates, in quantities to suit, for immediate use.

4. The *Extract of Malt* is the same as the above, obtained by the evaporation of ready prepared beer to dryness, and its composition is undecomposed sugar, soluble gluten, from the grain, and bitter substances from hops, and yields about eight per cent. from good beer. The nutritive qualities of beer depend upon the amount and nature of this extract, and the less fermented beers contain most of the extract. English ale

contains four per cent. ; small beer, fourteen per cent. ; while the German drinks, scarcely half fermented, contain as much as thirty-nine per cent.

5. Beer contains, as a matter of course, alcohol, the result of fermentation ; and this varies in quantity quite as much as the extract. For instance :

Small beer	contains but	1½	per cent.	alcohol.
Porter	“	5½	“	“
Brown stout	“	6½	“	“
Bitter and strong ale	“	10	“	“

And upon this alcohol depends the intoxicating effect of malt liquors. The English ales contain about the same strength, and have the same influence, as hock and light French wines. Beer is moreover food as well as drink, on account of the large amount of nutritive matter it contains, and is only distinguished from wine by the bitter, narcotic principle of hop.

The *Chica*, or Indian-corn (maize) Beer, which is a common drink of South America, is prepared in the same manner as any other beer. Indian corn is malted instead of barley ; and the liquor after fermentation is of a dark yellow color, and has an agreeable, slightly bitter, acid taste. This universal beverage, along the west coast of South America, is the only beverage of the country. The *Chica mascada* is the chewed corn, used for converting it into the *chica*. It is considered far superior to that prepared from corn crushed in the usual manner ; and the hosts in the valleys of the Sierra know no greater luxury to offer their guests and strangers than a draught of the *chica mascada*, the ingredients of which have been ground between their own teeth.

7. *Bouza*, or Millet Beer, or *Murwa*, is a fermented beer from millet seed. Among the Crimean Tartars, it produces an excessively astringent beverage. On the southern slopes

of the Himalaya mountains, the millet beer is in general use, where it is drunk while still warm; is served in bamboo jugs, and sucked through a reed. It tastes, when fresh, like the negus of Cape Sherry.

8. The *Quarf*, or Rye Beer, is a favorite Russian drink, resembling the bouza in taste and appearance, except that it is made from fermented rye flour.

9. The *Koumiss*, or Milk Beer, is a fermented liquor, produced by the addition of yeast to milk. It is the milk sugar, along with the curd and butter, which produces the fermentation, transforming it into alcohol and carbonic acid. Mares' milk is richer in sugar than the milk of the cow. It takes two days for preparing, and has a sourish taste. In a cool place, in close vessels, it may be preserved for several months. It is always shaken before it is drunk. It is a nourishing as well as exhilarating drink, and is not followed by the usual bad effects of intoxicating liquors. It is even very beneficial in dyspepsia and in general debility. It is very easily prepared by diluting new-milk with one-sixth of its bulk of water, adding a quantity of starch, and covering the whole up in a warm place for twenty-four hours. It is then churned together till the curd and whey are intimately mixed, and is again left at rest for twenty-four hours. It is then put into a tall vessel, and agitated till it becomes perfectly homogeneous. This beer is the favorite drink of the Tartars. The Arabians and Turks prepare a similar milk beer.

10. The *Ava*, *Cava*, or *Arva*, is a beer prepared from the root of the long pepper, and is in use in the South Sea Islands, all along the Pacific Ocean, in Tahiti, Sandwich Islands, Tonga Islands, and Feejee Islands. It is similar in its preparations to the chica. The root is chewed, either fresh or dry, as the Indian chews the maize; the pulp is then mixed with cold water, which after a little while is strained

from the chewed fibre, and is ready for use. None but young persons, who have good teeth, clean mouths, and have no colds, are employed in this operation. The women often assist in chewing the ava root in the Tonga Islands. The ava drinking of the king at Somu-somu, one of the Feejee Islands, is very peculiar and attended with much ceremony, both religious and political.

§ V.—GENERAL REMARKS ON BEER.

The difference in the varieties of beer is of course in the materials employed for the production of fermented liquors, or in the process and management of brewing. Malt beer differs according to the kind of malt employed, and according to the proportion of hops and water. It differs from wine, not only in containing less alcohol, but also in containing a much larger quantity of nutritive matter. It owes also its intoxicating property to the bitter and narcotic ingredients of hops. The specific gravity of small or table beer never exceeds 1.025, and contains about 5 per cent. of the malt extract, while ale, such as Burton's, is as high as 1.111; porter, 1.055; and brown stout, 1.072. The color of the beer depends upon the color of the malt, and the duration of the boiling in the copper kettles. Pale ale is made from steam or sun-dried malt, and the young shoots of the hop; amber ale, from a mixture of pale, yellow, and brown malt; dark-brown beer, from partially carbonized or parched malt; and porter from high-dried malt,—hence its deep color, and the absence of any sweet taste, having lost by heat its saccharine matter; while ale has a sweetish taste, and contains a much larger quantity of saccharine matter. A main feature of good beer is its fine color and transparency. Various substances are used for refining, muddy or foul beer, such as isinglass and Irish moss; and some brewers add even the Iceland moss, which not only assists in clarifying, but also

in imparting a pleasant bitter taste. The temperature and the manner in which the worts are made to ferment have a remarkable influence upon the quality of beer, especially in reference to its fitness for keeping.

§ VI.

There are two kinds of fermentation, the *upper* and the *lower* or bottom fermentation. The former is a much more active fermentation; the gluten is only partially oxydized at the expense of the oxygen of a portion of the sugar, while a great portion remains dissolved in the liquor, and by its subsequent oxydation is apt to transfer oxygen to the alcohol and render it sour, unless it be kept at a very low temperature. This is still more the case, if, during too violent a fermentation, the temperature rises too high, and especially if the air be not perfectly excluded, or a considerable quantity of acetic acid be formed, by which an additional quantity of glutinous matter is dissolved; and it thus is not only apt to spoil from the slightest causes, but loses also its liquidity, and assumes a disagreeable taste, what is called *yeast bitten*.

By the lower fermentation, on the contrary, the conversion of the sugar into alcohol is performed very slowly, and without any considerable rise of the temperature; so that the gluten is completely oxydized and precipitated by the oxygen of the air, and without conversion of the alcohol into acetic acid; so that the resulting beer—as all the Bavarian beers for example—is not liable to become sour. When this is not the case, the tendency to become sour is generally remedied by a large addition of hops and a greater proportion of malt, by which the beer becomes more narcotic and intoxicating, and less agreeable to the taste.

§ VII.—ALES AND BEERS.

1. The Scotch ale is characterized by its pale amber color and its mild balsamic flavor, and the bitterness of the hop is so mellowed with the malt as not to predominate. The low temperature at which the Scotch brewer operates in the colder months of the year, and his nicety in selecting his malt and hops, will always keep him pre-eminent to the other manufacturers of the world.

2. The Bavarian beer is fermented very slowly, and at a very low temperature, by the so-called lower or bottom fermentation; and it is incapable of undergoing the acetous fermentation, even by free exposure to the air. It keeps for years without turning sour. In the south of Germany a light beer is prepared from various amylaceous substances besides the barley, such as potatoes; beans, turnips, beets, carrots, &c.

3. The Strasburg ale is mainly manufactured from mashed potatoes, mixed with about one-tenth of their weight of ground barley malt. This is mixed with some water, and exposed in a water bath to a heat of 160° , whereby it is partly converted into saccharine matter, and may then be boiled with hops, cooled and fermented into beer.

§ VIII.

There are several kinds of beverages called beer, *par excellence*, but very improperly, as they are made from saccharine liquors, and advanced more or less into the vinous fermentation, and flavored with peculiar substances; such as spruce, ginger, and root-beer, which I will shortly enumerate in their place.

1. *Ginger-beer*.—This beverage, a favorite summer drink in the United States, is prepared quite simply in the following manner: To 3 gallons water add $\frac{1}{4}$ pound bruised gin-

ger-root, 2 ounces cream tartar, and 4 pounds sugar; boil for a few minutes, and after cooling, add about 1 gill of fresh yeast; cover up the vessel with a thick flannel, and let it stand over night; add a little essence of lemon, strain it, and bottle the liquid in clean bottles, and tie the corks down by means of twine or iron wire: on the fourth day the beer is fit to drink.

Another English ginger-beer is prepared by boiling $1\frac{1}{2}$ ounces pulverized ginger, 1 ounce cream tartar, 1 pound sugar, with $\frac{3}{4}$ gallon water; when cold, add a little yeast (a tablespoonful): the following day it is filtered, and drawn into bottles and well corked.

2. *Spruce beer* is prepared by putting into the common soda-water bottles about half a drachm (30 grains) of super-carbonate of soda, some essence of spruce (about 10 drops), and about half a drachm of crystallized tartaric acid; fill the bottle quickly with spring-water, cork, and tie it with twine.

3. The most agreeable *Lemonade gazeuse*, or portable lemonade, is obtained by boiling down the sugar syrup until it becomes feathery; it is then broken up and weighed, and thrown into bottles containing the solution of cream of tartar and bicarbonate of soda, when no carbonic acid can escape.

4. *Root-beer* is prepared by boiling various roots kept by the Thompsonian herb dealers, such as sarsaparilla, comfrey, liquorice-root, and sassafras blossoms and bark, in the same way as the ginger: and by adding to every two gallons of such decoction about two pounds of sugar; and when dissolved, add a gill of yeast to the same quantity, let it ferment over night, and the following day the beer is fit for drinking.

5. *Lager-bier*, the most popular drink in the United States, is prepared only in the winter months, and in the same manner as the Bavarian beer. The quantity of lager-bier consumed in the United States is incredible; for, in the

city of New York there are about twenty breweries: their production during the winter months is 30,000 gallons each, which will give for the city 6,000,000 gallons, a very low estimate. The beer keeps in the large vaults very well without becoming sour, and some beer tastes very well after being brewed a year.

The lager-bier establishments in this city, Brooklyn, Williamsburgh, and Staten Island, are very extensive, and large fortunes have been realized since its introduction into this country.

§ IX.

Adulterations are often practised in the manufacture of beer, for the purpose of imparting a heading or frothing, or giving it a bitter taste: alum, salt, and gentian-root are added for the latter; capsicum, grains of paradise, ginger-root, coriander-seed, and orange-peel, are also added to give pungency and flavor: also cocculus Indicus, quassia, tobacco leaves, yarrow-herb, stramonium-seed, calamus, coloring, copperas, aloes, ragicakes made of onions, black pepper, and capsicum, are all substances more or less used for adulteration of beer. For the purpose of giving age to new beer, or make it taste as if eighteen months old, some sulphuric acid is added.

CHAPTER III.

WINES.

THE distinguishing characteristics between wine and beer are, that beer quenches the thirst, exhilarates the spirits, and is, at the same time, nourishing, which is not the case with wine. Wine, however, is free from all bitter or narcotic ingredients. Wine is also produced by a spontaneous fermentation, without the addition of yeast.

§ X.—APPLE WINE OR CIDER.

The expressed juice of the apple contains grape sugar already formed. When left to itself, it begins to ferment without the addition of yeast, and during this fermentation the sugar is converted into alcohol. Cider differs in flavor, in acidity, in strength, as also in quality. The kinds of apple which are grown and used for the purpose, the degree of ripeness they are allowed to attain before they are gathered, the time given them to mellow or ferment before they are crushed, the skill with which the several varieties are mixed before they are put into the mill, the nature of the climate, the character of the season, the quality of the soil—all these circumstances materially affect the quality of the expressed juice as it flows from the crushing-mill; and then again, the after-treatment of the juice may produce a difference in the ripe ciders. There are certain characteristics in which all ciders agree: they are refreshing, contain little extractive or solid nutritious matter, but neither a bitter nor a narcotic ingredient. They contain on an average nine per cent. of alcohol. In strength, cider resembles the common hock-wine.—

Cider soon runs to acid, or becomes sour: it is then called hard cider.

The manufacture of cider is as follows:

The expressed juice from the apples, right after coming from the mill, is thrown into casks, with bungs lightly covered, but quite full to the brim, for a fortnight; and after six weeks the liquor is drawn off. An addition of five pounds of sugar to the barrel, causes the cider to become more vinous: apple-juice, quickly boiled and made into syrup, if added, will produce a pure cider. An addition of five per cent. of starch sugar will assist materially in increasing the strength and make it keep longer.

Imitation Cider.—In many parts of the country where cider is not made, and commands therefore a high price, the cupidity of the trader in that article is stimulated to adulterate it; and I have examined several times such a cider, which has been produced by the mixture of five gallons good sweet cider, two gallons fruit vinegar, or common wine vinegar, two gallons white syrup made from sugar, to twenty-five gallons of water. In one instance, I could distinguish a very small quantity of the oils of apple and pear, say one ounce of each to the barrel. This imitation cider tastes very well; and by adding about one gallon of purified whisky, may be made to keep for a length of time.

§ XI.—WINES PROPER.

Grape Wine.—The fermented juice of the grape is the wine proper. This juice, like that of the apple, contains the ready-formed grape sugar, and it enters speedily into spontaneous fermentation, just like the juices of the apple, the pear, the gooseberry, the currant, and other fruits. Within half an hour, in ordinary summer weather, the clearest juice of the grape begins to appear cloudy and to thicken, and to give off bubbles of gas. Grape wine differs in a multiplicity

of circumstances in itself,—in the climate of the country, the nature of the season, the soil of the locality, the variety of the grape, the mode of culture, the time of gathering, the way in which the grape-fruit, when gathered, is treated and expressed, the mode of fermenting the juice or must, the attention bestowed upon the young wine, and the manner in which it is treated and preserved.

§ XII.

All wines contain a certain quantity of alcohol, according to the quality and kind. It varies even in the same kind. The Spanish and Portuguese wines contain three times more alcohol than those of France and Germany.

Port contains on average, by measure, 20 per cent.				
Sherry;	"	"	"	25 "
Madeira,	"	"	"	20 "
Claret,	"	"	"	12 "
Tokay,	"	"	"	10 "
Rhenish,	"	"	"	12 "
Burgundy	"	"	"	12 "
Moselle,	"	"	"	9 "
Champagne,	"	"	"	10 "

The grape wine contains more or less undecomposed grape sugar, which gives a sweet taste and a fruity character to wines. *Dry wines* contain but little free sugar. Champagne wine, which contains but little free sugar, requires an addition of sugar, for the purpose of giving it body, to keep it sparkling, and to prevent its becoming sour. In fact, the sweetness of some wines, like Tokay, Malmsey, and Samos, and the extreme fruitiness of some port wines, is indicated by the large proportion of sugar which those varieties of wine sometimes contain.

§ XIII.

Grape wine contains a variable portion of free acid and

tartaric acid, but wines made from unripe grapes contain sometimes citric acid.

Tartaric acid exists in the juice of the grape, in combination with potash, and is called cream of tartar, or argols. This substance has a well-known sour taste. When the fermented juice is left at rest, this salt (bitartrate of potash) gradually separates from the liquor, and deposits itself as a crust or tartar on the sides of the casks or bottles; hence, by long keeping, good wines become less acid.

Grape wines owe their agreeable vinous odor, or flavor, to an ethereal substance, called Cœnanthic ether, which, in a separate state, is a very light fluid, of a sharp and disagreeable taste, but having an odor of wine so excessively powerful as to be almost intoxicating. It does not exist in the juice of the grape, but is produced during the fermentation; and as the odor in old wines is stronger than that in new wines, it therefore increases in quantity. So powerful is the odor of this ether, that few wines contain more than $\frac{1}{4000}$ part of it in bulk. It is the general characteristic of all grape wines.

In combination with the cœnanthic ether, all wines contain one or more odoriferous, more or less fragrant, substances, to which the peculiar bouquet or scent of each is due. As these give the special character to the wine, they are more or less different in each variety. The bouquet is contained in even more minute quantity than the cœnanthic ether, and its nature has, as yet, escaped the examination of the chemist.

§ XIV.

Many wines are produced from the fermentation of various fruits and roots, a few of which I will here enumerate. The price of good wines, and the high duty imposed in this country, have induced many dealers to substitute almost every wine, either by taking 5 gallons of the genuine wine, and

adding 15 gallons of pure spirits, 15 gallons of water, and 2 gallons of white syrup; and add either sugar coloring (burnt sugar), or in cases where the coloring does not produce the desired color, juice of the cherry, whortleberry, or elderberry is substituted. The quantity of water and pure spirits varies according to the strength of the respective wine to be prepared. A number of the wine-mixers do not use any genuine wine for their compound, but rely upon their skill to produce a beverage somewhat resembling a certain wine. In this manner, port, sherry, Madeira, muskat, and claret wines are falsified, and manufactured in this country by thousands of gallons, and partly sold in original packages, or put up in bottles, as the claret wine is disposed of in great quantities, by dozens, at public sales in this city and New Orleans.

§ XV.

The wines are arranged in quality according to the following table.

RED WINES.

FIRST CLASS.

<i>Dry Wines.</i>	<i>Greasy Wines.</i>	<i>Cordial Wines.</i>
Chateau Lafitte,	Romanée,	Lacrimæ Cristi,
" Margaux,	Conti, Richebourg,	Cap Constantin,
" La Tour,	Clos de Vougeat,	Messerée Essence Chiras.
" Haut Brion.	Chambertin,	
	Hermitage, 1st quality.	

SECOND CLASS.

Chateau Rosan.	Volnay, Vosne,	Rivisaltes, Pouillour.
" La Rose.	Poinnard, Nuits, Beaune,	Pedro Ximenes, Malaga,
" Leoville.	Côte Rotie, Cahors,	Tinto de Rota, Aleatico,
Jurançon, Bouzy,	Benicarlo, Cassis, &c.	Falerner.
Asmanshausen,		
Erlau, Port.		

THIRD CLASS.

Pouillac, St. Julien.	Comas, Marseller.	The red Muscat wines of
Persac, Mareuil Affenthal,	St. George, Geory,	various countries,
Walvarzheimer,	Chassauge.	Piccardan,
Melnicker.		Grenache Maccabeo.

WHITE WINES.

FIRST CLASS.

Dry Wines.
Chateau Johannisberg,
Leisten, Stein, Berg,
Markobrun, Gelsenheim,
Sillery.

Greasy Wines.
Hermitage, Sauterne,
Barsac, Mont Rachat,
Ay, &c.

Cordial Wines.
Tokay, Commandery,
Riveaultz, Canarisect.

SECOND CLASS.

Scharlachberg,
Stein Wine, Raster,
Xeres, Vino d'Oro, &c.

Straw Wine of Würzburg,
Collmar, St. Peray,
St. Jean, Condrieux,
Madeira, &c.

Malvoisier,
Monteflascone,
Alicante, St. George,
Calabrese, &c.

THIRD CLASS.

Leubenheim,
Markgraffer, Forster,
Bauderacker,
Reasmelyer,
Czernosecker, &c.

Landirac, Pyroles,
Cosmas, Langon,
Blois Wine,
Teneriffe, &c.

Linel, Piccardon,
Marsalla, Maccabeo,
Carcavelho, &c.

§ XVI.—THE FINING OF WINES.

Great care has to be used in pressing the grapes, fermenting the must, and settling the wines, in employing clean casks, and in keeping them constantly filled, else the fermented material cannot be removed. Notwithstanding all this, a new wine may from many causes—either the unfavorable season or some unknown mismanagement—be so situated as not to become clear. If we observe this heaviness of wine, the drawing off from one cask into another will remove the difficulty; but in case the wine is too cloudy and heavy, we have to resort to the clearing or fining operation, which is performed by numerous materials,—

1. By white sand, mixed with the white of eggs;
2. By small flint-stones;
3. By cream of tartar;
4. By isinglass, or fish sounds, or fish glue;
5. By gum-arabic and gum tragacanth;
6. By burnt and ground horn;
7. By filtering through felt;
8. By gelatine.

Isinglass and the white of eggs are mostly employed in effecting this object. Half an ounce of isinglass, soaked previously in one gallon of wine, and, when properly gelatinized, thrown in a barrel of the wine, will completely clear it in a week; and after a fortnight or three weeks, it may be drawn off into another barrel.

The neutralization of the wine, which is the case when old wine has become sour, or when young wine will not settle down its tartar, is done by adding a very small quantity of tartrate of potash, about one ounce to the barrel of such wine; and after the lapse of a week the wine becomes clear and free from acid.

§ XVII.—THE CONSUMPTION OF WINES.

The production of all the wines in Europe is 15,500,000 bottles, for a population of 240,000,000 souls.

In France, the largest culture and revenue is from wine, and more than six millions of the inhabitants are engaged in its traffic. It furnishes 525,000,000 bottles (40,000,000 hectolitres), at a value of 700,000,000 francs. The quantity of Champagne from the Department de la Marne is estimated at 2,700,000 bottles.

England consumes about 8,000,000 gallons; and their most favorite wines are the Portuguese red wine and Spanish Sherry wines—that is, fifty per cent. of Portuguese, forty per cent. of Spanish, and the rest of French, Cape, and Madeira wines. England produces a few fruit wines; such as cider, pear, and gooseberry wine—about 250,000 gallons in all.

Russia imports largely Champagne wine—about 800,000 bottles; also about 30,000 hogsheads of Greek and Moldavia wines, and but 50,000 gallons of French wines. Russia produces in the Crimea a considerable quantity of wine—about 500,000 hogsheads; in Bessarabia, nearly 3,000,000 gallons. The art of improving their native wines is well under-

stood in Russia, and carried on to great extent. The light wines are exposed to the frost; and the remaining strong wine is highly prized.

The production of wines in the Custom-Union of Germany (Zollverein), in which Prussia, Bavaria, Saxony, Wurtemberg, and all the minor possessions, are included, is 2,000,000 ohmes, or 166,000,000 bottles.

The United States produce but 300,000 gallons. They import from France alone 4,000,000 gallons; and the aggregate value of all the wines imported, 8,000,000 of gallons, is estimated at \$5,000,000.

CHAPTER IV.

§ XVIII.—WINE BEVERAGES.

1. EVERY liquid containing sugar and yeast may be converted into a wine; but in order to make the same resemble a grape wine, various ingredients have to be added; as, for instance, an acid, spices, and coloring, and an astringent to replace the extractive matter. The water to be used in the manufacture of wines ought to be soft; the acid is generally the tartaric; and for the coloring, whortleberry (huckleberry) and elderberry juice is used.

The quantity of alcohol contained in the fruit wines averages about ten per cent. Cider has a specific gravity of 0.977, and contains ten per cent. of alcohol. Pear wine and elderberry wine the same. Gooseberry wine has a specific gravity of 0.985, and has eleven per cent. of alcohol. Currant wine has a specific gravity of 0.976, and contains nineteen per cent. of alcohol.

The wine of the apple, which is called cider, has already been described.

2. The wine of the pear is a very pleasant beverage, and is prepared in the same way as the cider. It is a very good material for producing a sparkling wine.

3. Cherry wine, from the sour cherry, is a very pleasant wine.

4. The quince wine likewise yields a better result than apples. They are all prepared by boiling for half an hour the expressed juice, with its equal weight of water, and adding one pound of sugar to half a gallon of the watery juice, and the white of egg, which is stirred up with some water,

and brought to boiling over an open fire, so as to boil slowly, whereby the scum is taken off. The whole is left to ferment for about six weeks, when it is fit to be drawn off in bottles, quickly tied and wired, and after the lapse of four weeks the wine is ready for use.

I.—BERRY WINES.

1. *Raisin Wine*.—To 3 pounds of raisins add 9 pounds of water, 1 pound of sugar, $\frac{1}{4}$ pound cream of tartar, and an addition of yeast, in order to bring the liquid to fermentation. If the wine is intended to be consumed at once, it is not necessary to add any yeast.

2. *Gooseberry Wine*.—The unripe berries are used for producing a superior wine. An equal quantity of sugar is added to the squeezed berries, and left for one day, and then pressed. To the juice so obtained, add one-quarter of its weight of sugar and one-eighth of water, and a little cream of tartar; for two days the mixture is left at a warm temperature. As soon as the fermentation begins, the liquid is put into barrels, filled up to the bung, until the fermentation diminishes, when the bung is driven into the barrels. Keep in a cool place for two or three months, and then the liquor is drawn off from the yeast. The barrels may again be frequently stirred, in order to keep the wine in after fermentation. It will now become sparkling, and may be drawn off in bottles, quickly corked and tied over; but if left to farther fermentation, a superior still wine will be produced.

3. *Currant Wine*.—The berries, separated from the stems, are pressed, and the juice mixed with an equal quantity of water; and to each gallon of liquid add $2\frac{1}{2}$ pounds of sugar, 2 ounces of cream of tartar, 1 ounce of nutmegs (pulverized), 1 quart of alcohol, and a handful of lavender flowers, leaving the whole to ferment for several days; and proceed in the same way as with the gooseberries: but one-third

more water and loaf-sugar may be added to the juice if the currant wine is intended to be drunk soon. By boiling first the berries before pressing, some advantage may be obtained.

4. *Black-Currant Wine* is obtained in the same way as above; but the berries must be absolutely boiled before pressing, in order to remove the peculiar taste of the berries. The black currants yield a superior wine, similar to the grape wine of the Cape.

5. *Raspberry, Mulberry, Whortleberry, Cranberry, Juniper, and Strawberry*, are all used on account of their peculiar aroma, as an addition to other wines. Their juice ought only to be added after the completion of the fermentation.

6. *Blackberry Wine* is made from ripe berries, without the addition of any sugar; but if not quite ripe, they require an addition of sugar and water.

7. *Elderberry Wine*.—To 100 pounds of the berries, free from stems, squeezed and boiled, add 50 pounds of sugar, 2 pounds of cream of tartar, and 30 gallons of water, and let the mixture ferment like the other berry wines. By adding a little ginger, cloves, raisins, and yeast, it will yield at the termination of the fermentation a wine similar to the Greek (Cypria) wine.

8. *Damson Wine*.—Ten pounds of damsons, when quite ripe, are bruised and boiled in $1\frac{1}{2}$ gallons of water, then pressed from the pulp; add 3 pounds of white sugar; let it ferment in the barrel, and add, after a fortnight, a little good brandy to it, and it will be quite mellow and fit to fill in bottles.

§ XIX.—II. ROOT WINES.

Not only the roots, but many other parts of trees and plants, will yield a wine which, when properly prepared, can compare with the best grape wine.

1. *Birch and Maple Wine*.—From the juice running from the trees when tapped in the spring, a very fine wine is obtained. The sweet juice is mixed with sugar, cream of tartar, and elder flowers. After being first boiled down, always removing the scum, it is left for fermentation for several days; when finished, filled in bottles.

In order to obtain a sparkling wine, add to 24 parts of juice, 6 parts of sugar, $\frac{1}{4}$ lb. cream of tartar, and some elder flowers, and interrupt the fermentation sooner, as is done in the other berry wines.

2. *Carrot Wine*.—This makes a very wholesome wine; needs very little sugar to produce fermentation.

3. *Potato, Yam, and other farinaceous roots*.

4. *Palm Wine or Toddy*.—In the plains of the Indian Archipelago, the Moluccas and the Philippines, a wine is prepared from the sap of the gommuti palm. The Batavian arac (arrack) is distilled from the same juice. The toddy is the palm wine from the cocoa-tree. In order to procure the sweet sap from the spathe, or flowering head of the palm-tree, it is tapped near the top of the tree, below the crown. The incision is made by sloping upwards and inwards, and a vessel is hung below the wounds, and the juice conducted into it by a small bamboo. Not only the cocoa-tree, but also the date-palm, the fan-palm, and also the oil-palm of the West African coast, yield a rich sap, which, as it flows from the tree, is sweet, but when allowed to stand for a short time, begins to ferment, becomes intoxicating, and afterwards acid. The date juice tastes when fresh like rich milk, but when allowed to stand over-night, ferments, and acquires the sparkling quality and flavor of champagne.

It is said that the palm wine is more drunk as an exhilarating liquor, by a larger number of the human race, than the wine of the grape.

5. *Sugar-cane Wine* is the intoxicating liquor produced

from the fermented sap of the cane. The negroes call it *guerapo*.

6. *Agave Wine*.—In Mexico a favorite drink is prepared from the sap of the American aloe. The sap, as it flows, has a very sweet taste, and none of that disagreeable smell which it afterwards acquires: it is called *agua-miel*, and ferments spontaneously. After twenty-four hours it is ready for drinking, and is called *pulque*.

7. *Ginger Wine*.—To 5 gallons of water add 10 pounds of white sugar, and convert it into syrup by boiling. Boil separately $\frac{1}{2}$ pound of white Jamaica ginger-root in 1 gallon of water, adding a few lemon-peels to it while boiling: then mix both liquids, and add a little yeast, and also a few pounds of stoned raisins. Let it ferment for several weeks, and then add $\frac{1}{2}$ pound of tartaric acid and 1 gallon of elderberry-juice. Instead of the ginger-root, the essence of ginger may be employed—say $\frac{1}{2}$ pound of the essence to 6 gallons of the fermenting liquor.

8. *Lemon Wine*.—To 5 gallons of syrup, prepared from 10 pounds of sugar and 5 gallons of water, add the juice of 1 dozen of lemons. Let it ferment with a little yeast, and towards the end add $\frac{1}{2}$ gallon of Madeira wine and $\frac{1}{2}$ gallon of good brandy.

§ XX.—III. SUGAR AND HONEY WINES.

1. *Sugar Wine* is prepared by letting the solution of sugar and water ferment with a little yeast, and afterwards adding 1 ounce of tartaric acid to the gallon of fermented liquors, and the essences of pear and banana, each $\frac{1}{2}$ ounce; oil of cloves and cinnamon, each 20 drops. Starch or grape sugar produces a better wine than the cane sugar.

Another mode of preparing sugar wine (which I will call the *Columbia Wine*), is to add to 8 gallons of soft water 16 pounds of grape sugar, 2 ounces cream tartar, 8 lemons

(juice and peel), 2 ounces ginger (essence), 1 ounce of sage herb, $\frac{1}{2}$ gallon of rum, and about $\frac{1}{2}$ gallon whortleberry-juice.

2. *Honey Wine (Metheglin)*—an old time-honored German beverage. It is prepared by diluting 1 pound of honey with 4 pounds of water—boiling them for 1 hour (skimming continually)—leaving to ferment with yeast, and hanging into the barrel a bag containing several bruised spices, such as coriander seed, cloves, ginger, and calamus, each $\frac{1}{2}$ ounce. The fermented liquor will be clear after one month.

§ XXI.—IMITATION OF WINES.

Such wines as are prepared artificially, by compounding or imitating the ingredients of the natural wines, and not by fermentation, are brought into this class.

1. *Madeira Wine*.—For 1 barrel of said wine mix,—

- 2 gallons of white-sugar syrup,
- 2 “ of honey,
- 10 “ of pure spirit,
- 10 “ of cider,
- 10 “ common Hungarian wine,
- 10 “ water, or German light wine,
- 1 pound of tincture of hops,
- $\frac{1}{2}$ “ of essence of Madeira wine,
- 2 gallons of elderberry-juice,
- 1 “ of whortleberry-juice.

2. *Burgundy Wine*.

- 2 gallons sugar syrup,
- 10 “ red wine,
- 2 “ cherry-juice,
- 10 “ cider,
- $\frac{1}{2}$ pound essence of wine,
- 10 gallons pure spirit.

3. *Medoc Wine.*

- 10 gallons of red wine,
- 1 gallon of raspberry-juice,
- $\frac{1}{2}$ pound of essence of claret,
- 5 gallons of pure spirit,
- 10 " of water,
- 5 " of cider,

Additional red coloring of tincture of Saunders' wood,

- 1 gallon of sugar syrup.

4. *Malaga Wine.*

- 4 gallons of sugar syrup,
- $\frac{1}{2}$ ounce oil of pimento, dissolved in 1 gall. alcohol.
- $\frac{1}{2}$ pound essence of port wine,
- 10 gallons of white wine,
- 5 " of pure spirit,
- 5 " of water,

Sugar coloring sufficient to color.

5. *Muscat Wine.*—Digest in

- 10 gallons of white wine,
- 15 pounds of large raisins,
- 15 " of currants; and add
- 4 gallons of white sugar syrup and
- 1 dram of oil of vitriol.

Let the whole mixture digest and ferment for some days; then the clear liquor is drawn off, and let it finish in the barrel until it is perfectly clear; then add,

- $\frac{1}{2}$ pound of essence of port wine,
- 1 gallon of whortleberry-juice,
- 10 gallons of pure spirit,
- 5 " of water.

6. *Canary Wine.*—20 pounds of raisins, without stems, are digested and boiled in 10 gallons of water, to which are

added 5 pounds of gooseberry-juice, and left to ferment with 4 gallons of syrup of white sugar; then add $\frac{1}{2}$ pound of essence of Madeira wine, 5 gallons of pure spirit, and 1 gallon of water.

7. *Tokay Wine*.—20 pounds of raisins are digested in 10 gallons of water, and, with the addition of 4 gallons of syrup, left for fermentation for 24 hours; then add $\frac{1}{2}$ pound of essence of Madeira wine, 5 gallons of pure spirit, and 10 gallons of white wine.

8. *Port Wine*.—10 gallons hard cider,
 1 gallon whortleberry-juice,
 2 gallons elderberry-juice,
 1 pound essence of port wine,
 2 gallons sugar syrup,
 10 “ pure spirit,
 10 “ soft water.

The color may be made darker by the tincture of malva, or by the flowers themselves, which require to be steeped for twenty-four hours in the spirit. They yield a very dark color, which is not affected by the cider.

It may be here remarked that cider, which is the base of many wines, cannot be had at all times of the year, nor in all parts of the country, and the substitute is invariably tartaric acid, of which half a pound will replace ten gallons of cider.

9. *Bordeaux or Claret Wine*.—To a decoction of 1 pound of orris-root, in 5 gallons of water, add 1 gallon of raspberry-juice, 10 gallons of pure spirit, $\frac{1}{2}$ pound of essence of claret, 1 gallon of sugar syrup, and the coloring produced from cochineal.

10. *Sherry Wine*.—The juice of cherries, currants, whortleberries, and elderberries, each $\frac{1}{2}$ gallon; 2 gallons of sugar syrup, 10 gallons of pure spirit, 20 gallons of water, and $\frac{1}{2}$ pound of essence of Madeira wine.

11. *Rhine Wine*.—The above mixture of juice, with the addition of gooseberry-juice, the essence of wine in a very small portion, and the essence of claret wine, 10 gallons of cider, 10 gallons of pure spirit, and 10 gallons of water.

§ XXII.—I. SPARKLING WINES.

All wines may, by a proper method, be made to sparkle; and it is well known that the greatest part of the Champagne wine exported from Europe is nothing else than a common light wine, made to ferment again, and by bottling the same quickly, so as to allow the fermentation to be going on in the bottles.

All sparkling wines are prepared—1. By adding to common white wine a little rock-candy (half a pound to the gallon), or a simple addition of white-sugar syrup: starch sugar may also be employed for this purpose; and then the whole mixture to be saturated with carbonic acid gas, by means of a pump, in the same manner as the soda-water in bottles is prepared. Care ought then to be taken to have a pure carbonic acid gas employed for impregnating the mixture of wine and syrup. It ought always to be washed before letting it enter into the fountain.

2. By subjecting a mixture of syrup—made from the best white sugar and a good light white wine, to which any other substances or berry-juices may be added at pleasure—fermenting for four to six weeks in corked bottles, and then separating the settled yeast, and refilling again, and treating them with an addition of carbonic acid gas, a good sparkling wine is obtained. Young wines are apt to become sparkling much sooner than old wines; but old wines produce a better champagne.

3. By treating good white wine with sugar and raisins, and allowing them to ferment, in which process the sugar yields the material for fermentation, and the wine may con-

tain some gum, in order to retain the better the carbonic acid gas; and then the taste which champagne is apt to have, to be got from the taste of the raisins.

4. *Champagne from Gooseberries.*—To 20 gallons of ripe, mashed gooseberries, add 18 gallons of boiling water, and a few ounces of orris-root and ginger-root, and boil for half an hour; then strain, and add yeast, 50 pounds of white sugar, 1 pound of cream of tartar, and $\frac{1}{2}$ pound of rock-candy, and let the whole ferment for several weeks; then add 1 gallon of good brandy and $\frac{1}{4}$ pound of dissolved Russia isinglass. Stir up the whole mixture, and set the casks, tightly bunged, aside for several months. Draw off, after three months, in bottles well corked and wired. The result is a very good imitation of champagne.

5. *Champagne Cider.*—To 100 gallons of good cider, put 3 gallons of strained honey, or 24 pounds of good white sugar; stir them up well, and set it aside for a week. Clarify the cider with $\frac{1}{2}$ a gallon of skimmed milk, or $\frac{1}{4}$ pound dissolved isinglass, and add 4 gallons of pure spirits. After two or three days bottle the clear cider, and it will become sparkling.

In order to produce a slow fermentation in the manufacture of champagne, not only are the casks containing the fermenting liquor to be bunged up tight, but also the new wine is to be put in casks well burnt with sulphur. It is a great object to retain much of the carbonic gas in the wine, so as to develop itself after being bottled.

CHAPTER V.

§ XXIII.

1. THE *colors* which are used to imitate the exact colors of the original wines, are—1. The malva flowers or holly-hock. They produce, when steeped in spirits for twenty-four hours, or even when boiled with water, a very beautiful purple color.

2. The pokeberry (the dark berries from the plant growing all over the United States) has a very dark red color.

3. Whortleberry, elderberry, and blackberry.

4. Brazil-wood, Saunder's-wood, and logwood. These woods are boiled in water, and the decoction yields shades of color from red to blue.

5. Cochineal gives a fine red color, by boiling finely-ground cochineal with cream of tartar.

6. Orchill produces a beautiful purple color.

7. Red beets and carrots produce likewise a good color.

8. Indigo solution, neutralized by potash, produces a fine blue color.

9. Annatto and extract of safflower produce a beautiful yellow color.

10. Turmeric is the most common color for yellow, as the spirit extracts all color immediately; as also quercitron bark.

11. Red cabbage produces a beautiful bluish-red color.

12. Guaracine, or extract of madder, produces various shades of red.

13. Tincture of saffron (Spanish saffron) for yellow.

14. Blue vitriol, or solution of indigo, produces blue.

15. Burnt sugar produces a fine and permanent brown color for wines. It is best to boil down common sugar or

loaf-sugar nearly to dryness. It is then dissolved in hot water, sufficient to make the consistency of syrup; and for the purpose of neutralizing it and making it a more permanent color, add to each gallon of sugar-color about one ounce of liquid ammonia.

16. Green color for absynth is prepared from a solution of extract of indigo and turmeric, dissolved in spirits.

17. Violet color is obtained by a solution of extract of logwood and alum.

18. Barwood color, which acquires a dark wine-red color by digesting in alcohol.

19. Brazil-wood, by being macerated in alcohol, or by boiling for half an hour, produces a deep red color.

Peach-wood, or Nicaragua or Santa Martha wood, Japan-wood, Lima-wood, Braziletto—which are all synonymous—produce beautiful shades of red colors in liquors.

20. Alkannet-root produces a fine blue-red color by macerating in alcohol.

TABLE

Of percentage (100 parts) of alcohol, in the various fermented liquors, by measure. The alcohol having a specific gravity of 0.825 at 60° Fahrenheit.

	Proportion of Alcohol. Per cent by measure.
1. Lissa wine, average per centage.....	25.41
2. Raisin, " "	25.12
3. Marsala, " "	25.09
4. Port, " "	22.96
5. Madeira, " "	22.27
6. Currant, " "	20.55
7. Sherry, " "	19.17
8. Teneriffe, " "	19.79
9. Colares, " "	19.75
10. Lachrymæ Christi.....	19.70
11. Constantia, white.....	19.75
12. " red.....	19.75
13. Lisbon.....	18.94
14. Malaga.....	18.94

FERMENTED LIQUORS.

	Proportion of Alcohol. Per cent. by measure.
15. Burellas.....	18.49
16. Red Madeira.....	20.85
17. Cape Muscat.....	18.25
18. Cape Madeira.....	20.51
19. Grape.....	18.11
20. Calcavella.....	19.20
21. Vidonia.....	19.25
22. Alba Flora.....	17.26
23. Malaga.....	17.26
24. White Hermitage.....	17.48
25. Rousillon.....	19.
26. Claret, average.....	15.10
27. Zante, ".....	17.05
28. Malmsey Madeira.....	16.40
29. Lunel.....	15.52
30. Sheraaz.....	15.52
31. Syracuse.....	15.28
32. Sauterne.....	14.22
33. Burgundy, average.....	14.57
34. Hock, ".....	12.08
35. Nice.....	14.63
36. Barsac.....	18.88
37. Teat.....	18.30
38. Champagne, still.....	13.80
39. " sparkling.....	12.80
40. " red.....	12.56
41. Red Hermitage.....	12.32
42. Vin de Grane.....	18.94
43. Frontignac.....	12.79
44. Coté Rotie.....	12.32
45. Gooseberry.....	11.84
46. Tokay.....	9.88
47. Elderberry.....	8.79
48. Cider.....	8.00
49. Perny.....	7.26
50. Mead.....	7.32
51. Burton Ale.....	8.88
52. Edinburgh Ale.....	6.20
53. Brown Stout.....	6.80
54. London Porter.....	4.20
55. Bavarian Beer.....	4.00
56. Philadelphia Ale.....	4.00
57. Poughkeepsie Ale.....	3.75
58. Lager-Bier.....	3.
59. Small Beer.....	1.28
60. Brandy.....	58.29
61. Rum.....	53.68
62. Gin.....	57.60
63. Scotch Whisky.....	44.32
64. Irish Whisky.....	53.90

CHAPTER VI.

§ XXIII.—ARDENT SPIRITS, ALCOHOL, BRANDY, AND ALL OTHER LIQUORS.

EVERY fermented liquor, as has been already described, when distilled in a close vessel, so that the vapors can rise and be conducted by a pipe into a cooled receiver, condenses these vapors into a liquid state, the result of which is an ardent spirit, generally called spirits. Its radical is called alcohol. But the spirits distilled from the various substances that have a flavor, carry the same over with the distillation, and is generally distinguished by a name of its own; thus wine, when distilled, is called brandy, or Cognac; fermented molasses yields rum; Indian-corn, potatoes, and rye yield liquors which are distinguished as corn, rye, and potato spirits; while malt liquors (from barley) yield the Scotch and Irish whiskies. If juniper berries are added to the liquor previous to distillation, as is done in Holland, the flavor is imparted to the spirits, and is called gin; and if the malt is dried over a peat (turf) fire, the spirit assumes the flavor and tastes of the peat, which is considered a very favorite drink. Although malt and other liquors, fermented in the usual way, will yield brandy by distillation, yet, the distiller by profession conducts his fermenting operations in a different way from the brewer; for, in fermenting the wort for the manufacture of beer, a large proportion of the sugar is left unchanged, it being prevented from being transformed into alcohol, for the purpose of making the beer more pleasant and to keep without turning sour. The distiller's object is, however, to get the largest quantity of spirits from the grain, and to do this he prolongs the fermentation until all the sugar is transformed into alcohol and carbonic acid.

§ XXIV.

It is, however, a fact, that the most esteemed grain-spirit is obtained, when only malted barley is employed in the manufacture of spirits, as the best malt whisky of Ireland and Scotland. The distillers use also a great proportion of unmalted grain, or even potato starch, for the following reasons: the grain consists essentially of two principal substances, *starch* and *gluten*, which, when moistened under favorable circumstances, cause the grain to sprout; as the sprouting proceeds, the starch is converted by a chemical process into soluble grape sugar, and the gluten is changed, among other products, into a white soluble substance called diastase; this again transforms the starch, during the germination of the barley, into sugar, and in this way the same diastase is capable of transforming nearly a thousand times its own weight of starch; therefore, a large quantity of starch, either in the form of crushed unmalted grain, or of potato starch, may be mixed with ordinary malt, and the diastase will operate on the same and transform it into sugar. The distiller's main object is to gain as much whisky as possible from his grain, in order to save the expense of malting and the loss of eight per cent. which the barley suffers in malting. He may use other grains as an addition to the malted barley, although the sweet wort, when fermented and distilled, yields a somewhat harsher or less pleasant flavor than when malt alone is used. For illustration of the above remark, it may be stated, that some Scotch distillers use the following mixture for their whisky :

Malt (barley),	42 bushels,	at 40 lb. per-bushel.		
Oats,	25	"	47	" "
Rye,	25	"	58	" "
Barley,	158	"	58	" "
			<hr/>	
			250	

The diastase in the forty-two bushels of malt converts into sugar the starch of the whole two hundred and fifty bushels, weighing eight times as much as the malt itself. This quantity of grain yields on an average five hundred and eighty-three gallons of proof-whisky, or fourteen gallons from six bushels of the mixture.

§ XXV.

By the distillation of fermented liquors, the spirit which passes over contains always a small but variable proportion of one or more volatile oily liquids which mix with the spirits, and give it a peculiar flavor. These volatile oils vary in kind, in composition, and in sensible properties with the kinds of sugars which have been submitted to fermentation, and with the substances which are present along with the wort; hence the spirit obtained from almost every different kind of fermented liquor is distinguished by its own characteristic flavor: thus wine, brandy, or Cognac, derives its vinous flavor from the juice of the grape, and Cognacs of different districts their special flavor from the kinds of wine which are distilled in each. Rum obtains its smell and taste from molasses—the scorched and altered juice of the sugar-cane; whisky its peculiarities from the barley-malt or grain that is mixed with it; potato brandy from the mashed potato or its skin. In each case, a volatile substance, peculiar in kind, accompanies the spirit, and though this substance is always very small in quantity, it is yet sufficient to impart to each different variety a flavor at once characteristic and peculiar.

The volatile spirit of potato, which is called amyle alcohol (fusel oil), appears to be identical with the same amyle alcohol of the Cognac distilled in the south of France from the grape husks, and it is therefore to be presumed that the contamination must in all cases lie in the skin or epidermis of

the roots and berries. The ardent spirits are chiefly distilled from raw and malted grains, such as barley, rye, and oats in Europe, but from Indian-corn or maize in the United States; rye is mostly employed in the north of Europe and Holland, and potatoes in the south of Europe, and particularly in Germany.

§ XXVI.

The principle of all ardent spirits is alcohol, and it is obtained by distilling the rectified spirits of wine of commerce with substances having a strong attraction for water, such as pearl-ashes, quicklime, and chloride of calcium. Alcohol obtained by simple re-distillation of the common rectified spirits, has a specific gravity at 60° Fah. of 0.825, and is therefore considerably lighter than water, which is 1.000. It is a limpid colorless liquid, with an agreeable smell, and a strong pungent flavor; it never freezes, but boils at a temperature of 176°.

The purest alcohol obtained by rectification has a specific gravity of 0.791; usually, however, but 0.820.

CHAPTER VII.

§ XXVII.—ALCOHOL AND COMMON SPIRITS OR WHISKY.

THE pure spirit obtained by distillation from all liquids that have undergone the vinous fermentation, is called alcohol; this again is distinguished between absolute alcohol and alcohol of commerce, or spirits of wine, which is absolute alcohol mixed with different proportions of water and a volatile oil, just as they run over from the still or the distilling apparatus.

No. 1.—SIMPLE STILL.

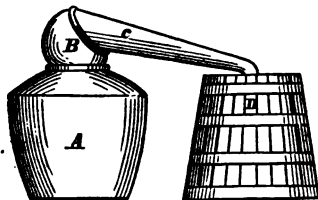

No. 2.—PISTORIUS' STILL.

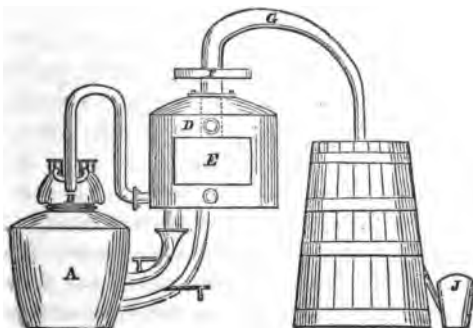

The distillation is performed in an ordinary still or kettle, with its capital or helm and worm, as described in fig. 1.

A represents the kettle in which the wort is put; B the helm, which fits tightly on the same, for receiving the spirituous vapors rising in the kettle when heated; these vapors pass through the tubes into the cooling apparatus D, which is ordinarily filled with cold water, so that the vapors passing through C may be condensed and pass as a liquid into E. The product is a weak spirituous liquor, containing much water; and, in order to obtain a strong alcohol, several repeated distillations are requisite. Many improvements have been made, by which a concentrated alcohol may be procured by a single distillation from fermented worts, wines, and other weak spirituous liquids. The principle of all the improvements depends upon the fact, that the boiling point of alcohol is higher in proportion to its content of aqueous vapor; or, that the temperature at which alcoholic vapors condense is lower when the content of water is smaller, and in direct proportion until we approach absolute alcohol.

Pistorius has succeeded in constructing an apparatus, which consists in the kettle for the liquid to be distilled (No. 2), letter A, the helm B, and the pipe C, passing into the water condenser E; the vessel D, where the hot pot E is visible, is used for heating the wort before entering the still or the wort-warmer, in order to promote the boiling point; at the same time, the cold wort coming into the vessel D, tends to cool down the spirituous vapors contained in E, and to determine, by cooling, to convert the water vapors into a liquid, and the alcoholic vapors to escape and pass through the vertical pipe into the basin F, which is a hollow and convex vessel: this is flat beneath, and has a rim around its edge to detain the vapor for a moment. The cold water flowing over it promotes refrigeration, and the watery alcoholic vapors are condensed and fall back, while the al-

coholic vapors pass through the pipe G upwards, and down in the worm contained in the cooler H, and from thence into the receiver J, and contains high-proof alcohol.

PERFECT DISTILLING APPARATUS OF DR. GALL.

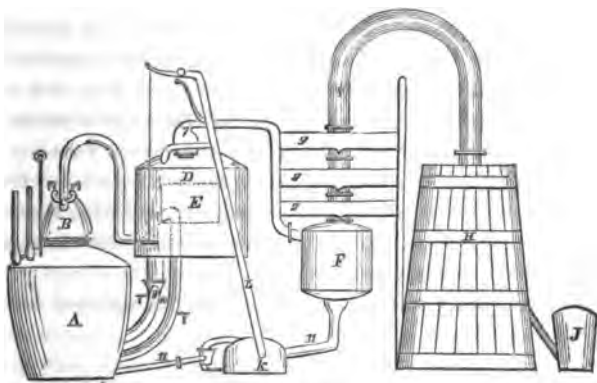

SIDE VIEW.

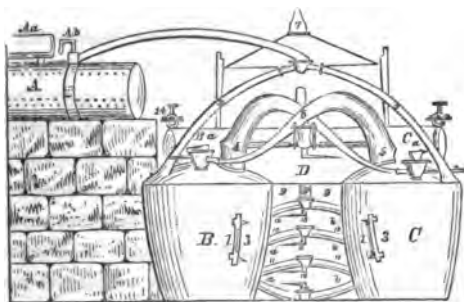

FRONT VIEW.

Letter A is a steam-boiler which supplies the heat to the whole apparatus; Aa is the feeder, a small boiler for heating the water to the boiling point, to supply the water lost by being converted into steam; Ab is the safety valve applied

to the steam-kettle for the purpose of letting off such steam by its own pressure, or to let off the steam if necessary to stop the operation, or to interrupt the operation for some cause or other. The stills B and C, with their caps B_a and C_a, as also the wort-warmer D and the Condenser E, have all been described, and are now shown in the plate; the rectifier F, and above it, the condensers C, are in this apparatus prominent. F is to separate the water vapors from the alcohol vapors which may have come over from the condenser E by the tube, then to pass them into the convex vessels *g*; after passing through there, these vapors are forced into the large pipe 8, and thence into the cooler H, and from thence into receiver J; the vessel K contains all the wort ready to be pumped up into the still.

By this operation a strong alcohol may be obtained by a single distillation.

§ XXVIII.—THE PROCESS OF PREPARING THE CORN TO BE DISTILLED FOR THE MASHING OPERATION.

The malt has already been described under the head of beer; the next operation is the mashing, boiling, and cooling, which is to convert the malted corn into wort. The corn and other grain is crushed and ground between iron rollers into a coarse powder and then introduced into the mash-tun, which is a large circular tub with a double bottom, the uppermost of which is called a false-bottom, and is pierced with many holes, leaving a space of about two or three inches between the bottoms, into which the stop-cocks enter, for letting in the water and drawing off the wort; the mash-tun is provided with a rotary apparatus for agitating the crushed grain and water together, consisting of a perpendicular shaft in the centre of it, which is turned slowly around by means of wheels at the top, and arms projecting from the axis supporting the short vertical axis of the wheel,

so that when the central axis is made to revolve, it will carry this axle around the tun in a circle. This axle is furnished with a number of horizontal arms or blades, placed obliquely to the plane of their motion, which, when turned around by the axis and wheel, agitate the malt in the tun and give it a constant motion upwards from the bottom. Mashing has not for its object merely to dissolve the sugar and gum already present in the malt, but also to convert the starch, which remains unchanged during the germination, into a sweet mucilage, by the diastase which has been formed by the process of germination. When the mash is to begin, water is first heated in a copper vessel, and then let into the mash-tun; it is now well agitated and left for about an hour, and the temperature raised to 150°. The tun is now well covered for the preservation of the heat, during which time all the remaining starch is first converted into dextrine and then into sugar; the tap of the tun is then opened and the wort drawn off: a considerable quantity of wort remains in the drained mash, and a fresh quantity of boiling water has to be introduced into the tun, and the mixture agitated until it becomes as uniform as before, when the second wort is drawn off. The exhausted malt is used for feeding the cattle; but the wort is then raised by pumps to the coolers, and placed in an airy situation: it is of importance to cool it down as fast as possible. The common cooler is a square wooden cistern about six inches deep, and the refrigeration is generally effected in six or seven hours.

§ XXIX.

The fermentation of the wort is then undertaken. When the wort is discharged into the fermenting-tun, it receives its proper quantity of yeast, which has been previously mixed with a quantity of wort, and left in a warm place till it has begun to ferment. This mixture, called *loff*, is then put into

the tun, and stirred well through the mass. The quantity of yeast used depends upon the temperature, strength, and quantity of the wort; generally, however, one gallon of yeast is sufficient to set one hundred gallons of wort in complete fermentation, which generally lasts from fifty to sixty hours. The whole operation is divided into four periods:—1, the fresh wort; 2, the rising fermentation; 3, the decreasing fermentation; and 4, the liquor ready for distillation.

1. The wort, which is quite sweet, remains for the first five hours quiet and clear in the covered tun.

2. A white milky-looking froth appears and spreads gradually over the whole surface, and a perpetual disengagement of carbonic acid gas takes place, small bubbles constantly rising to the top; the warmth of the fermenting liquor increases in temperature from 10° to 150° , and this period lasts from twelve to thirty hours.

3. After that the fermentation decreases, the bubbles become now smaller and less frequent, the wort returns to its original volume, which period lasts from sixteen to thirty-six hours.

4. The surface has now become quite smooth, the upper crust of the surface disappears, and the wort becomes clear. It has a pleasant odor and taste, and it is ready to be put into the still.

The fermented liquor is drawn into both kettles by pumps, and only two-thirds filled, in order to prevent the boiling over, and the whole equalized by the pipes *9 a* and *9 b*, and the quantity ascertained by the two glass-tubes *13*. The steam is now raised, and is either carried through the pipes *1*, *2*, and *3*, either in one or the other stills, and by these pipes the vapors in both stills equalized.

The alcoholic vapors are driven from the capital *C a* and *B a*, and pass through the pipe *6* into the vessel *E*. This vessel is, as already remarked in a former paragraph, to con-

dense the water vapors by means of the surrounding cold wort, and to let the alcoholic vapors pass on through the pipe 7 into the rectifier F. This vessel has been kept warm enough not to let the alcoholic vapors condense while the water vapors will precipitate and form water. These vapors, which are coming from the rectifiers E and F, just mentioned, pass through the pipe 8 into the metallic vessels 9. They are constantly surrounded with cold water, and carry, therefore, all the alcohol that drops through the cooler H, which is likewise filled with cold water, and the alcohol runs into the receiver J.

The liquids contained in E and F, containing some alcohol mixed with the water, are afterwards drawn through the pipe 11 into one or the other still, for being distilled over, like the first process.

§ XXX.

The yeast, which forms a very important part in all these operations, deserves to be explained in this place, for fermentation is solely dependent upon the condition and general qualities of the yeast.

Yeast, as formed during the fermentation in beer, is nothing but gluten, and all albuminous matters are converted into yeast. The yeast which rises to the top of any fermenting malt liquor, is composed of ovoidal globules of very minute size, $\frac{1}{2500}$ inch in diameter; the surfaces of which often have minute appendages, which are regarded as germs attached to their producing cells, which, when fermentation progresses, move about in all directions, indicating that they have vitality, and are organized beings. When a liquid contains an excess of ferment, the latter continues acting until all the sugar is converted into alcohol, and then loses its properties as a ferment in the same liquid; or its existence ceases, because its nourishment, the sugar, is removed.

It is said that fermentation is effected by a vegetable, and putrefaction by an animal production, and that by only one species of infusory animal. When sugar is added to a liquid containing these animals, a vegetable body, ferment, is produced; and when more sugar is added, the production of the animals ceases, and that of the ferment is increased; for the upper or common fermentation, the globules are larger, and have smaller globules branching off from them, which act as germs to produce yeast. There are also three alcoholic ferments distinguishable,—the common-beer yeast of larger globules, with germs, which completes fermentation in a few days, at from 50° to 85°, and cannot act in a strong alcoholic liquid; ferment of lees, called the lower ferment, of smaller globules, which acts between 50° and 55°, and completes its process in three or four months, even in liquid of 16 per cent. alcohol; and black ferment, of still smaller globules, which produces fermentation in not less than six months. The gluten which transforms the sugar by the oxydation, or by the attraction of oxygen, into carbonic acid and alcohol, is, at the same time, undergoing a material change, by being made during this operation insoluble, on account of the presence of water.

§ XXXI.

For producing good Yeast.—Rye and barley are the grains which are prepared, when malted, for the purpose of obtaining a good yeast. Brewers' yeast is the most common in use, but in many cases a fresh yeast has to be prepared. The following method is adopted for procuring a good lasting yeast:

Take 20 pounds of wheat-meal, 10 pounds of rye-meal, and 10 pounds of malted barley, and make them into a paste with boiling water; keep covered for four hours, and then boil 4 ounces of hops in about 2 gallons of water, and reduce

to 1 gallon, and add it to the meal-paste, and macerate the whole for an hour. Eight ounces of pearl-ashes and 1 gallon of upper yeast are then added, and left to ferment for twenty-four hours, when the yeast is ready for use.

To each 100 pounds of malt, about half a gallon is required for fermentation. This yeast will keep a long while, and may also be dried and preserved as dry yeast.

Another receipt for making family yeast is the following:—Boil half a dozen peeled potatoes quite soft; mash them fine, rub half a teacupful of flour in them, and add a teaspoonful of salt. Put the whole mass back into the potato water; while lukewarm, add one cent's worth of bakers' yeast: let it rise, and it is then fit for use.

Yeast is also made sometimes by the addition of about twelve ounces of oil of vitriol, diluted with water, to 100 pounds of malt, for the purpose of assisting the yeast in raising and making it bulky.

§ XXXII.

Having hitherto treated upon the production of spirits, it is necessary at present to state, that all the spirits derived from the first distillation is not free from other foreign substances; it is well known that wine and fermented liquors generally contain, in addition to the alcohol, other substances which could not be detected before their fermentation, and which must have therefore been formed during that process; the smell and taste distinguishing wine from all other fermented liquids, are known to depend upon an ether of a volatile and highly combustible acid. The ether is of an oily nature, and is called œnanthic ether; and it is also well ascertained that the smell and taste of brandy from corn and potatoes, are owing to a peculiar oil—the oil of potato spirit, fusel oil. This oil is more closely allied to alcohol in its properties, than to any other organic substance.

CHAPTER VIII.

§ XXXIII.—THE RECTIFYING PROCESS OF WHISKY AND ALCOHOL.

THE usual process to purify the first product of distillation from the oil, acid, and other substances contaminating the smell and taste of the spirits, and in order to make it fit for chemical purposes, as well as for all other applications the same is put to in daily life, is by redistilling the whisky in a common still at a low temperature. The usual and most common rectification of whisky is performed cold, by passing it through charcoal filters once or twice, when the spirits is called rectified whisky or spirit. For the purpose of effectually freeing the spirits from all its impurities, a number of methods are proposed—either acids, alkalis, salts, fatty oil, vegetable and animal coal. The animal coal (ivory-black) is the most powerful vehicle for purifying the whisky.

To 10 pounds of the common bone-black add sufficient water to make a paste, in which 1 ounce of oil of vitriol is mixed, well stirred, and left over-night; the water is then poured off and a fresh quantity of water added, until all taste of acid has disappeared; the bone-black is then dried. In a sieve-like bottom of the rectifying cask, from three to four inches from the bottom, lay the bone-black over a layer of straw; a second sieve-bottom is then put in the cask, upon which is put 20 pounds of fresh-burnt, coarse-grained charcoal, from pine-wood, 5 pounds of manganese, and 1 pound of calcined magnesia, provided with a fresh layer of straw, and another finer sieve containing washed and dried sand. In the cask is now put another bottom, through which the spirits to be rectified is to run.

To the whisky which has to be rectified is added 2 ounces

of spirits of hartshorn, and then it is to be thrown into the rectifying cask; after three days contact the pure spirits is drawn off.

This rectifying apparatus will turn out a good spirits for a whole year, but the operation must not be stopped during that time.

Spirits, in every way suitable for the manufacture of liquors of the finest quality, such as a good Cognac brandy, rum, &c., ought to be distilled after being first treated with 6 pounds of oak-bark, half a pound of purified sal tartar, and a quarter of a pound of slaked lime to each cask, and left to digest or macerate for ten or twelve hours: this is performed in the simple distilling apparatus (fig. 1), and by drawing three-quarters of the quantity first employed, a spirit is obtained equal to the best French spirit.

It is a fixed fact, based on chemical principles, that the spirits dissolves all essential oils, resins, and vegetable matter, and will be the more intimately united the longer it is in contact with the same. It requires, therefore; the skill and knowledge of the experienced to overcome this difficulty, and to endeavor by powerful agents to separate those substances kept in solution of the spirits, and on this knowledge of the facts the act of distillation and rectification depends altogether. It has been ascertained that the sulphuric acid has the property of destroying all vegetable matter, and may itself be again neutralized by alkalis. By combining sulphuric acid with the spirits (whisky), it produces an astringent taste and destroys the fusel oil without reducing the strength of the spirits; all that is then required is to precipitate the so destroyed fusel oil, and to purify the spirits from that as well as the excess of oil of vitriol, which is done by adding afterwards a little sal soda. To each ounce of sulphuric acid take three ounces of sal soda, and every foreign substance contained in the spirit is thereby precipitated.

Such a spirit requires about a fortnight for becoming again clear, when the whole mass is precipitated to the bottom. For the purpose of purifying one barrel, holding forty gallons of raw whisky, or impure spirits or alcohol, pour four ounces of pure sulphuric acid (not the common oil of vitriol of the shops), stir it well with the spirits, and leave it in contact for three days—for the longer the acid remains free in the spirit the greater is the effect upon the fusel oil—then add twelve ounces of sal soda, dissolved in a little water, and pour the solution into the barrel: these quantities are the largest that may be used. For the purpose of testing the spirit, whether all the acid is fully neutralized, or whether the soda has been added in excess, take some litmus-paper; the blue litmus-paper must not be reddened, as that would show an excess of acid, nor must the red paper be turned blue, which would indicate the excess of the alkali, and no neutralization would be in the spirits.

For the purpose of communicating a stronger taste to the spirits, equal to an addition of about ten per cent., add about two ounces of chloride of lime, rubbed up with a little sal soda, and add then in solution to the spirit; also, an addition of two ounces of acetic ether contributes much to give the spirits the age of several years.

§ XXXIV.—THE RECTIFICATION OF THE SPIRITS BY CHARCOAL.

This process is altogether owing to the construction or porous nature of the coal, which absorbs the fusel oil and passes the spirits free from all other foreign substances. The coal from willow, poplar, linden, as also pine-wood coals, are the proper vehicles to let the spirits pass through: the coal must be free from dust, and of the size of half a hazel nut.

The rectifying cask is constructed in the manner well known in this country; but before filling the cask with the

charcoal to near its brim, within six inches from the real bottom, a coarse bag is put on the false bottom, containing the calcined magnesia, ivory-black, manganese, pipe-clay, and pearl-ashes, well mixed, spread, and covered by a willow bottom, upon which the charcoal is spread; for each 100 gallon cask use 3 pounds of calcined magnesia, 2 pounds of ivory-black, 2 pounds of German manganese, 2 pounds of white pipe-clay, and half a pound of pearl-ashes.

The spirits is at first left in the cask for twenty-four hours, and half of the quantity drawn off and refilled again; or in other words, the whole spirits to be rectified must pass twice through the cask: and in large establishments, where there are twenty or thirty such rectifying casks, the spirits is pumped into the casks, and is kept running from the casks and returned again, until the spirits run free from the fusel oil. The materials in the casks last from six to eight months, when they may be renewed by fresh materials and charcoal. After calculating the expense and loss of the spirits rectified in this process, the loss is not two per cent.

RECTIFYING WITH AN ADDITION OF SAND.

It is thought that by having a layer of coarse white sand on the lowest sieve or false bottom of the cask, and then the mixture of the other ingredients, the spirits will run clearer and stronger. Grocers and liquor dealers may, by means of two rectifying-tubs, kept in their cellars, produce daily, sufficient quantities of rectified spirits for their daily use from the raw whisky, and without any extra expense except some attention, so as to save from five to eight dollars per day. The drawing of both rectifiers, given on the following page, will explain the manipulation.

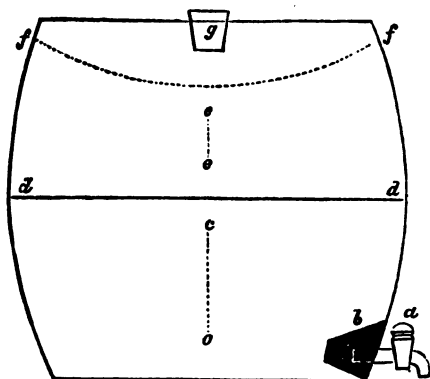

RECTIFIER.—No. 1.

a, the stop-cock, with a little basket *b*: *cc*, space filled with charcoal; *dd*, gunny-bag containing the mixture of manganese, &c.; *ee*, space filled with charcoal; *ff*, the top, and *g*, the bung.

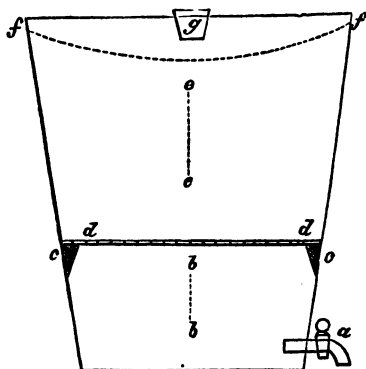

RECTIFIER.—No. 2.

a, the stop-cock; *bb*, space for collecting the purified spirits; *cc*, supporters for false perforated bottoms; *dd*, the

sieves, or false bottoms, covered by bagging—holding, first 2–3 inches of sand, and then the mixture as above; *ee*, space filled with charcoal; *ff*, the top; *g*, the bung.

§ XXXV.

In order to prepare any essential oil so as to be ready for manufacturing any desired liquor, as it is well known that almost all essential oils become rancid and almost insoluble in spirits, whereby the fine bouquet is lost: to avoid this, and to retain the perfume for any length of time, I have thought it advisable to give a mixture of half a pound of carbonate of magnesia, a quarter of a pound of pearl-ashes, and three pounds of white pipe-clay, in which one pound of essential oil is well rubbed up: then preserved in a glass-stoppered bottle, so as to be ready for use whenever required. The oil of juniper, oil of lemon, and oil of Cognac, are well known not to keep a great while, and the difficulty of preparing a good gin from even the best oil of juniper, if old, has been too frequently experienced by the best liquor manufacturers; but by preparing the oil as just described, this difficulty is overcome; it also saves time, if the oils are required at a moment's notice, while many oils require considerable time for their solution in alcohol. The oils so prepared are fit and will readily dissolve. In making absynth and Curaçao cordials, the oils of absynth and orange have often proved a failure, for the reasons just mentioned. It is necessary to mark on the bottles containing the oils what quantity of the oil has been rubbed up, so as to know the quantity to be used for the desired liquor.

CHAPTER IX.

§ XXXVI.

THE strength of spirit contained in alcohol is ascertained by an instrument called hydrometer, which is made of brass, with ballast-weights; it is called Sykes' hydrometer, and is constructed for the purpose of indicating, not the amount of absolute alcohol in a spirituous liquor, but the amount of spirit of a certain strength, which is generally known by the name of *proof spirit*. The term proof spirit originated from a crude method, formerly practised, of ascertaining the strength of spirits, by pouring it into a dish containing gunpowder and inflaming it: if it took fire, it was said that the spirit was *above* proof; if not, it was *under* or *below* proof. This, however, is a very uncertain test. According to an act of the English Parliament, the strength of *proof spirit* has been fixed, that thirteen volumes of spirit shall be equal in weight to twelve volumes of water, or have a specific gravity of 0.9186, at a temperature of 60° Fah., and to contain 57.27 per cent. absolute alcohol by volume, or 49.50 by weight. The strength of spirit is then indicated by a certain number *over* or *under* proof, indicating the number of volumes which are to be added to or subtracted from one hundred volumes of the spirit, in order to render it proof spirit: thus, by the expression, 10 over proof, is meant, that 100 gallons of the spirit would stand the addition of water till it formed 110 gallons, which would have the strength of proof spirit; and 10 below proof means, that so much water is to be abstracted from 100 volumes as would diminish it 10 volumes, in order to render it proof spirit, or that 100 gallons contain 90 gallons of proof spirit.

Proof spirit at 66° Fah. contains 48 per cent. by weight,

or 55.76 per cent. per volume of alcohol, and has a specific gravity of 0.9218 according to Ure. According to another act of Parliament, 100 parts of spirit and 100 parts of water is called fourth proof.

A liquor of 5° below Sykes' hydrometer is called third proof; a liquor of 10° below hydrometer proof is called second proof; and a liquor 15 below hydrometer proof is called first proof.

2. The following table gives a comparison between the indications of Sykes' hydrometer and the specific gravities corresponding to them :

SYKES' HYDROMETER.—Specific gravity 60° Fah.

Over Proof.		Under Proof.		
70	per cent.	0.8095	Proof	0.9200
64	"	0.8221	5 per cent.	0.9259
63.1	"	0.8238	10 "	0.9318
62	"	0.8259	11 "	0.9329
61	"	0.8277	15.8 "	0.9376
60	"	0.8298	17.1 "	0.9396
59.1	"	0.8315	20 "	0.9426
58	"	0.8336	22.3 "	0.9448
57.1	"	0.8354	23.1 "	0.9456
56	"	0.8376	25.1 "	0.9476
55.9	"	0.8379	30.1 "	0.9522
55.7	"	0.8383	40.1 "	0.9603
55.0	"	0.8396	50.3 "	0.9673
54.1	"	0.8413	60.4 "	0.9734
50.1	"	0.8482	70.1 "	0.9790
43.1	"	0.8597	80.4 "	0.9854
25	"	0.8869	90.2 "	0.9922
11.1	"	0.9060	100 water	1.0000

Whenever the percentage of alcohol is known by weight, the quantity of water by weight in the liquid is of course obtained by subtracting the percentage from 100. Not so, however, with the percentage by volume, since a contraction takes place by the mixture of alcohol and water. A spirit at 49 per cent. by volume, does not contain 51 volumes of water; but so much water as is necessary to make, with the 49 volumes of alcohol, 100 volumes of the mixture, which is more than 51 volumes of water.

3. The following table shows the different volumes of alcohol and water in 100 volumes of the mixture at 59° Fah.

100 volumes of spirit contain at 59° Fah.		100 volumes of spirit contain at 59° Fah.	
Volume of Alcohol.	Volume of Water.	Volume of Alcohol.	Volume of Water.
100	0.00	45	58.64
95	6.18	40	63.44
90	11.94	35	68.14
85	17.47	30	72.72
80	22.87	25	77.24
75	28.19	20	81.72
70	33.14	15	86.20
65	38.615	10	90.72
60	43.73	5	95.31
55	48.77	0	100.00
50	53.745		

The problem of producing a weaker alcohol from a stronger, depends on a knowledge of the contraction of alcohol by its mixture with water, and the following table serves how to find, if we wish to procure spirits of a certain percentage from alcohol of 90 per cent., or any other percentage, how much water or volumes of water is required for producing the desired spirit.

Desired strength in per cent.	90	85	80	75	70	65	60	55	50
85	6.56								
80	13.79	6.88							
75	21.89	14.48	7.20						
70	31.05	23.14	15.35	7.64					
65	41.53	33.03	24.66	16.37	8.15				
60	53.65	44.48	35.44	26.47	17.58	8.76			
55	67.87	57.90	48.07	38.32	28.63	19.02	9.47		
50	84.71	73.90	63.04	52.43	41.78	31.25	20.47	10.35	
45	105.34	93.80	81.81	69.54	57.78	46.09	34.46	22.90	11.41
40	130.80	117.84	104.01	90.76	77.58	64.48	51.43	38.46	25.55
35	163.28	148.01	132.88	117.82	102.84	87.93	78.08	58.81	48.59
30	206.22	188.57	171.05	153.61	136.04	118.94	101.71	84.54	67.45
25	266.12	245.15	224.80	208.53	182.83	162.21	141.65	121.16	100.73
20	355.80	329.84	304.01	278.26	252.53	226.98	201.43	175.96	150.55
15	505.27	471.00	436.85	402.81	368.83	334.91	301.07	267.29	233.64
10	804.54	753.65	702.89	652.21	601.60	551.06	500.59	450.19	399.85

The upper horizontal column contains the per cent. of the stronger alcohol; and the vertical columns below, the volumes of water which are to be added to 100 volumes of it, in order to produce a spirit of the strength indicated in the left-hand column. For example:—if we wish to procure a spirit of 20 per cent. from alcohol of 85 per cent., we take the number from the left-hand column, and find opposite, under the vertical column, 329.84, which are the number of volumes of water required to produce a spirit of 20 per cent. out of a spirit containing 85 per cent. of alcohol.

The general rules for mixing spirituous liquors are, if you wish to reduce spirits of a given number of degrees above proof (P), to a required number of degrees below proof, to multiply the number of gallons by 100, less the required number of degrees below proof; divide this product by 100, more the number of degrees which the given liquor is above P, and the quotient deducted from the original number of high proof gallons, will give the result.

For instance, to reduce a cask of 40 gallons of spirits at 36 degrees above P, to 5 degrees below proof:

$$\begin{array}{r}
 100 \\
 \underline{\quad 5} \\
 \text{To } 100 \qquad \text{Multiply } 95 \\
 \text{add } 36 \qquad \text{by } \quad 40 \\
 \hline
 136 \qquad \qquad : \qquad 3800 = 28
 \end{array}$$

Deduct the 28 from the original cask containing 40 gallons:

$$\begin{array}{r}
 40 \\
 \underline{\quad 28} \\
 = 12
 \end{array}$$

Therefore 12 gallons of spirits are to be taken from the cask and supplied by water, and the mixture will then be equal to 5 degrees below proof.

The 28 gallons of spirits at 36 degrees above proof, are equal to 38 gallons at proof; and this is done by reversing the operation :

Multiply	28 gallons	To	28 or gross gallons
by	<u>00.36</u>	add	<u>10</u> or the percentage
	10.08		38

Or, by multiplying 40 by 5 you obtain 200, and deducting these 2 from 40 will produce 38 gallons at proof; or, in other words, to 28 gallons of spirits add 12 gallons of water, so as to make 40 gallons, which, at 5 degrees below proof, will be equal to 38 gallons at proof.

For reducing high-proof (any high proof) spirits to proof spirits (proof spirits always mean a mixture of equal volumes of standard alcohol, of specific gravity 0.825, and distilled water): for coming to a result, multiply the given quantity by 100, divide that product by the number of degrees which the high-proof spirits are above proof, with the addition of 100, and the quotient thereof deducted from the original quantity will give the answer. For instance,—to reduce 36 gallons of spirits at 20 degrees above proof to proof :

20	36	36 gallons.
<u>100</u>	<u>100</u>	<u>30</u>
120	: 3600 = 30	6

Therefore 6 gallons are to be removed and replaced with water; and 30 gallons at 20 degrees above proof are equal to 36 gallons proof. The operation is the multiplication of the 20 percentage with the given 30 gallons, such as :

30	To 30 gallons
<u>20</u> percentage.	add <u>6</u> the percentage.
6	36 gallons proof.

The simple formula of reducing the spirits, is to multiply the quantity of spirits at a given per cent., and to divide by the derived per cent. less the quantity of the employed spirit.

100 gallons of alcohol at 80 per cent., to be reduced to 30 per cent.; how much water is required?

$$\left(\frac{100.80}{30}\right) - 100 = 166\frac{2}{3} \text{ gallons of water.}$$

For raising low-proof spirits to proof spirits with high proof spirits, multiply the number of gallons by the number of degrees which the high-proof spirits are above proof; divide the product by the number of degrees above proof, added to those below proof, and the result will give the number of gallons below proof, which, deducted from the original number of gallons, will give the quantity to be removed and replaced with high-proof spirits.

To raise 40 gallons at 15 degrees below proof to proof, with spirits 36 degrees above proof:

15 degrees below proof	40	
<u>36</u> " high "	<u>36</u>	
51	:	<u>1440</u> = 28½ gallons.

From 40 gallons	40.000
deduct	<u>28.235</u>

11.765 or 11¾ gallons.

Therefore 11¾ gallons are to be removed, and replaced with spirits 36 degrees above proof.

By multiplying the 11¾ or 11.775

by 36

4.235 the percentage.

4.235
add <u>11.765</u> gallons, or
16.000 gallons at proof,

nearly 4½

11¾

16

Multiply 28.235

From 28.235

by 15

take 4.235

4.235.25

To 24.000 = 28½

add 16.000 = 11¾

40	40
----	----

The $28\frac{1}{4}$ gallons at 15 degrees below proof, require $11\frac{3}{4}$ gallons at 36 degree above proof.

To raise low-proof spirits to above proof, multiply the number of gallons by the difference in degrees between the spirits to be added and those to which they are to be raised. This product divide by the sum of the degrees above proof and below proof, and the quotient will give the number of gallons below proof, which, deducted from the original quantity, will give the number of gallons to be removed, and replaced with high-proof spirits; and if the given spirits is at proof instead of 15 degrees below proof, the mode of operation is the same in this instance.

For example:—To raise 40 gallons at 15 degrees below proof to 5 degrees above proof, with spirits 36 degrees above proof:

36	15 above proof.	40	From 40.0
5	36 below “	31	take 24.3
<u>Diff. 31</u>	<u>51</u>	:	<u>1240 = 24.3</u>
			15.7

Hence $15\frac{7}{10}$ gallons are to be removed, and replaced with spirits of 36 degrees above proof.

By taking 24.3 at 15 deg. below proof = 20.7 gallons proof.

15.7 “ 36 “ above “ = 21.3 “

40.0 at 5 deg. above proof = 42.0 gallons proof.

Thus showing that the mixture of $24\frac{3}{4}$ gallons at 15 degrees below proof, with $15\frac{7}{10}$ gallons at 36 above proof, are equal to 40 gallons at 5 above proof, and both are equal to 42 net or proof gallons.

To raise spirits above proof to higher proof with high proof spirits, multiply the number of gallons by the difference in degrees between both proofs, and divide the product by the difference of the given proofs.

Raise 36 gallons at 20 degrees above proof to 25 above proof with spirits 40 degrees above proof.

From 40	36	25 required proof.
Take <u>20</u>	<u>5</u>	<u>20</u> given “
Diff. 20	: 180 = 9	5 difference.

36

9 gallons at 40 degrees above proof = 12.60

27 “ 20 “ “ = 32.40 proof.

Thus, 45.00 gal. = 36 gal.

at 25 degrees above proof.

To reduce spirits above proof to spirits of less degrees above proof with water, multiply the number of gallons by the difference between both proofs, and divide the product by the given proof added to 100.

For example:—Reduce 36 gallons at 30 degrees above proof to 20 degrees above proof:

30 given
20 required
 10

100 add 10
30 by 36

130 : 360 = 2.77 or $2\frac{2}{3}$ gallons water.

From 36

Take $2\frac{2}{3}$

$33\frac{1}{4}$ or 33.25 gal. at 30 above proof = 43.22 at proof
 36 “ 20 “ = 43.22 . “

To raise low-proof spirits to a higher degree of low-proof spirits with high-proof spirits, multiply the number of gallons by the difference between the given and required proofs, and divide the product by the sum of the proofs of the given and added spirits.

For example:—Change 36 gallons at 10 degrees below proof to 5 degrees below proof with spirits 20 degrees above proof:

FERMENTED LIQUORS.

$$\begin{array}{r}
 20 \quad 36 \quad 10 \text{ given} \\
 \underline{10} \quad \underline{5} \quad \underline{5 \text{ required}} \\
 30 : 180 = 6 \quad 5 \text{ difference.}
 \end{array}$$

From 36 gal. at 10 below proof

Take out 6 at " "

36 at 10 below proof = 27.00 gallons proof

Put in 6 " 20 above " = 7.20 " "

36 at 5 below proof = 34.20

To reduce low-proof spirits to lower proof with water, multiply the number of gallons by the difference of degrees between both proofs, and divide the product by 100 less the given proof, and the quotient will be the result.

For example:—Reduce 36 gallons 5 degrees below proof to 10 below proof with water:—

$$\begin{array}{r}
 \text{Required } 10 \quad 100 \quad 36 \\
 \text{Given } \quad 5 \quad \quad 5 \quad \quad 5 \\
 \text{Difference } 5 \quad : \quad 95 \quad : \quad 180 = 1.90 \\
 \quad \quad \quad \quad \quad \quad \quad \quad \quad \quad 6
 \end{array}$$

From 36.00

Take 1.90

34.10 from 34.10

5 take 1.70 = 5 per cent below proof

1.70.50 32.40 at proof = 36 gallons.

Or from 36 gallons

Draw off 1.90

In cask 34.10 at 5 degrees below proof

Add water 1.90

36.00 at 10 below proof.

To reduce high-proof spirits to a required lower proof, which will still be above proof, multiply the given number of gallons by the difference between the given and required

proofs, and divide the product by 100, adding the required proof.

For example:—How many gallons of water will be required to reduce 80 gallons of spirits 60 degrees above proof to 20 degrees above proof?

$$\begin{array}{r r r}
 60 & 100 & 80 \text{ gallons} \\
 30 & 20 & 40 \text{ difference} \\
 \hline
 40 & 120 & : 3200 = 26.67
 \end{array}$$

To reduce high-proof spirits to proof spirits. In this case the number of gallons to be added will equal the percentage.

For example:—To 80 gallons at 40 degrees above proof, how much water is required to reduce it to proof?

$$\begin{array}{r}
 80 \\
 \hline
 40 \\
 \hline
 32.00 = 32 \text{ gallons of water to be added.}
 \end{array}$$

To reduce spirits above proof to spirits below proof, multiply the given quantity by the sum of the given and required proof, and divide the product by 100 less the required proof.

For example:—To 80 gallons 40 degrees above proof, how many gallons of water to reduce it to 10 below proof?

$$\begin{array}{r r r}
 40 & 100 & 80 \\
 10 & 10 & 50 \\
 \hline
 50 & 90 & : 40.00 = 44.44 \text{ gallons of water.}
 \end{array}$$

CHAPTER X.

THE HYDROMETER.

THIS is a simple instrument, used for determining the specific gravities or densities of liquids, and sometimes of solids; it is based upon the hydrostatic law, that a floating body displaces its own weight of the liquid in which it swims; hence, the more dense the liquid, the smaller will be the quantity displaced, or the depth to which an hydrometer will sink in it. By varying the weight required to sink a body of given bulk, we may determine the specific gravities of liquids, as well as by measuring the relative volume displaced by one of immovable weight; and upon these principles hydrometers are constructed. The hydrometers of constant weight are all made either of metal or glass of well-known form. The hydrometer which is principally in use in this country is of silver-metal, and consists in form of a cylindrical stem, to which is appended a hollow ballast bulb, so as to cause it to float. That part of the stem above the bulb is graduated on each side; that below is not graduated, terminates in a loaded or solid bulb, and is accompanied by a movable regulating weight. The side marked P (proof) is sometimes graduated as high above P as 50° , and as low below P as 45° , and is used for weighing low or high-proof spirits; or, in other words, those which seldom exceed 45° above or below P, and in which instances the regulating weight is always retained during the operation. The opposite side, generally graduated as high as 100° , is used for weighing high-proof spirits or alcohol, in all which instances the regulating weight must be removed. This is done (if a screwed bulb) by unscrewing the loaded or solid bulb at the end of the ungraduated part of the stem, after which the

loaded bulb is to be replaced; but if a permanent or fixed bulb, by taking off the weight.

The hydrometer is necessarily accompanied by a thermometer, and a card, so as to regulate the degrees of heat or cold at which the liquor arrives, at the time of examination, of a standard temperature, which is 60° Fah. The several qualities of proof, as they respect the various differences in strength, are indicated on the different scales of the thermometer card by the letters O P, meaning over proof, and U P, for under proof.

§ XXXVII.

The hydrometer requires a thermometer for ascertaining the temperature of the spirits. When heated, it expands or becomes more rarified, while when cold, more intense and contracts; therefore, when at a high temperature, the hydrometer immerses to a greater depth in the spirits, while, when at a low temperature, it shows the reverse. The same spirits, when tested by the hydrometer in warm weather, or in a warm temperature, shows a sensible difference in the number of their degrees, from what it indicates when cold, or at a low temperature; and this difference has to be regulated by a standard, which is done in the following manner. When the tin or copper cylinder which accompanies the thermometer is filled with the spirits to be tested, and having immersed the hydrometer—1, note the number of degrees above or below P, where the liquor apparently cuts the graduated stem; 2, add or deduct the temperature of your liquor from the graduated column which agrees nearest with the degree cut by the hydrometer; 3, then from the number of degrees thus cut, reduce the number of the stem by as many degrees as the mercury stands above 60° Fah., and thus will the *true proof* be ascertained; but, 4, should the mercury stand below 60°, as in winter, then

raise or increase the number cut on the stem, at the time of observation, by as many degrees as the mercury is below 60° . Illustrations for ascertaining the true proof of spirits, according to variable degrees of temperature, are as follows :

1. If the stem of the hydrometer is cut by the liquor 42° above P., and the mercury stands at 70° , or 10 above the standard (60°) in the thermometer, what is the net proof?—*Ans.* 39° above P.

2. If the stem is cut at 5° above P., and the mercury stands at 68° , or 8° above 60° , the standard, what is the net proof?—*Ans.* 2° above P.

3. If the stem is cut at 68° above P., and the mercury is at 68° above 60° , what is the proof?—*Ans.* 5° above P.

4. If the stem is cut at 12° above P., and the mercury is at 5° below 60° , what is the proof?—*Ans.* 14° above P.

5. If the stem is cut at 15° below P., and the mercury is at 68° above 60° , what is the proof?—*Ans.* 18° below P.

6. If the stem is cut at 10° below P., and the mercury is at 7° below 60° , what is the proof?—*Ans.* 7° below P.

7. If the stem is cut at 10° below P., and the mercury is at 90° , or 10 below 60° , what is the proof?—*Ans.* 6° below P.

8. If the stem is cut at 14° below P., and the mercury is at 60° , what is the proof?—*Ans.* 14° below P.

9. If the stem is cut at P., and the mercury is at 60° , what is the proof?—*Ans.* P. net proof.

10. If the stem is cut at P., and the mercury is at 8° above 60° , what is the proof?—*Ans.* 3° below P.

11. If the stem is cut at P., and the mercury is at 8° below 60° , what is the proof?—*Ans.* 3° above P.

12. If the stem is cut at 5° below P., and the mercury is at 50° , or 10° below 60° , what is the proof?—*Ans.* P.

These examples have all been copied from Wright's *Cor-dialanica*.

CHAPTER XI.

§ XXXVII.—GENERAL TREATMENT OF SPIRITS.

IN using the solution of the ethereal oils in spirits, for the purpose of preparing the oils suitable for aromatizing the spirit and producing a clear liquor, it is required to rub the essential oils in the following mixture: 1 ounce of burnt alum and half an ounce of calcined magnesia—these must be powdered fine—and 2 ounces of any essential oil well tinctured with it; 1 quart of 90 per cent. alcohol is then added, which is afterwards put upon a filtering-bag: an addition of alcohol is then put on the filtering-bag for the purpose of depriving the mixture of any oil it may contain.

§ XXXVIII.—CLEARING OF LIQUORS.

Various substances are employed for clearing liquors which have become turbid or cloudy. The best preparation is the following:

In 1 quart of wine vinegar and 1 quart of water stir the white of 8 eggs; heat the mixture to 100° , let it cool, and fill the same in bottles for use if required. A very small quantity is sufficient, say 1 quart of the mixture to 1 barrel of any liquor which may have become turbid, to clarify any liquor.

Another preparation for clearing is:

Rub up half an ounce of burnt alum, half an ounce of prepared chalk, and the whites of two eggs in a pint of water.

The neutralization of the sharp taste of alcohol and all spirituous liquors is of the highest importance, as it contaminates the taste of every liquor, and it will always predominate when prepared with alcohol or spirits which was not

quite free from the fusel oil. I can safely recommend my preparation, which is called the age and body preparation, as it neutralizes entirely the bad taste of the spirits. It gives, likewise, the new spirit a taste which remains on the tongue like a liquor which has the age of several years. It may be employed on a large scale by the distillers and rectifiers for common whisky or corn spirit, Bourbon, Irish, and Scotch whiskies.

§ XXXIX.—PREPARATION OF THE WHITE SUGAR SYRUP WITH OR WITHOUT THE ADDITION OF GUM-ARABIC.

To 5 pounds of white sugar add half a gallon of soft water, which, when dissolved, put over a slow fire and keep it stirring, so as to prevent its burning; take off the rising scum, and add about one-quarter of a pound of starch sugar, as described under the head of sugars. The liquor prepared with such a syrup has an oily consistency and is well suited for all liquors. For gum syrup, add a solution of gum-arabic mucilage, made by dissolving 4 ounces of white gum-arabic in 1 pound of boiling water. The syrup is prepared at a slow fire, and will then not crystallize.

All the fruit syrups, such as raspberry, currant, blackberry, and others, are prepared by dissolving white sugar in the expressed juice of the berries, and boiling the syrup once.

Lemon syrup is prepared by dissolving 10 pounds of sugar in 3 quarts of boiling water for five minutes, and adding half a pound of tartaric acid and a quarter of a pound of the essence of lemon to it when cold.

CHAPTER XII.

§ XL.—DIVISION OF THE LIQUORS.

THE manufacturers of liquors prepare—I. The simple liquors.

II. The compound liquors or double spirits.

III. Cordials.

I.—As belonging to the simple liquors, I will mention—

1. The common rum, prepared by the distillation of all fermented saccharine solutions. The New England rum and Jamaica rum, distilled from molasses.

2. The arac, similar to rum, but prepared by fermentation of rice and cocoa-nut juice; also from the fruit of the areca and other palm trees in the West and East Indies.

3. The cognac, which is prepared in France from the low grades of wine by distillation. Originally the cognac brandy was obtained from the quinces growing in that country. The name of the quince in French is "le coing," and the same name has been retained for the cognac brandy made in that region.

4. Rochelle brandy, obtained by distillation of the grape lees and common wines, after having undergone fermentation, in the south of France.

5. Whisky, or spirit, from corn, rye, wheat, and barley, and therefore, also, the high wine rectified from them.

II.—The double or compound liquors are all those liquors which are prepared from essences and flavorings, or essential oils, &c.,—gin, apple or cider brandy, peach brandy, cherry, plumb, raspberry, and similar liquors.

III.—The cordials are mixtures of the best spirits, satura-

ted with essences or essential oils, with a large proportion of sugar, so as to be of an oily consistency. Curaçao, Maraschino, absinthe, anisette, Kirschwasser, &c., belong to this class.

1. The manufacture of rum has already been explained.

2. *For the manufacture of Arac.*

100 gallons of fine spirits of 50 per cent.,

2 pounds of the essence of arac, or St. Croix rum,

10 pounds of roasted and ground rice;

and, when well mixed, left for one week, stirring it several times a day; and then add 4 pounds of rock-candy, dissolved in hot water, and the whole left in a temperate place; after which, when clear, it will be suitable for use.

Another mode of making arac, is to put into a barrel containing 40 gallons—

10 gallons pure arac,

30 “ pure spirit,

in which some rice has been digested some weeks previously: say 5 pounds of the same to 30 gallons of proof spirits, 1 ounce of cocoa-nut oil, $\frac{1}{4}$ pound of the essence of arac, and about 1 ounce of the tincture of saffron.

3. *For Cognac Brandy.*—There are a great many methods proposed to imitate a good cognac brandy. It may be produced from the best cognac or grape-oil, the ænanthic ether, the extract of the grape-juice, or the essence of cognac.

(1.) *From Cognac Oil or the Ænanthic Ether.*—Dissolve 1 ounce of the best cognac oil in 1 quart of the highest-proof alcohol, and let it stand over-night; the following morning add 1 ounce of acetic ether, 1 ounce oil of apple, 1 ounce of essence of Jamaica rum, and 10 drops of the oil of bitter almonds to the alcohol; and in the cask containing 160 gallons of good proof spirits, rectified by the above prescribed method, add 1 gallon of syrup of gum-arabic, and—according to the color desired, either dark or pale brandy—1 gallon of sugar coloring and 1 quart of the tincture of white-oak bark.

(2.) *From the Essence of Cognac.*—For 60 gallons of pure spirits, take—

- 1 pound of the essence of cognac,
- 1 gallon of syrup of gum-arabic,
- 1 “ of sugar coloring,
- 1 quart of oak-bark tincture,
- 1 ounce of acetic ether.

(3.) *From the Extract of the Grape-juice.*

- 1 pound of the extract of cognac,
- 1 gallon of syrup of gum-arabic,
- 2 “ of sugar coloring,
- 200 “ of pure spirits.

(4.) *From the Brandy flavoring.*—Each gallon of the brandy flavoring is put into 1 barrel (of 40 to 45 gallons capacity) of pure spirits (French purified spirits), and, according to the color desired, from $\frac{1}{2}$ to 1 gallon of sugar coloring is added.

To add, if it is desired, about 5 gallons of pure imported brandy for each barrel containing the mixture, a more expensive, and perhaps also a more improved brandy may be thereby obtained.

The Rochelle brandy is imitated by the extract of cognac: say 1 pound to 5 barrels of pure spirits, as above described, and adding sufficient coloring; $\frac{1}{2}$ pound of essence of violet, 1 gallon of syrup of gum-arabic, 1 quart of tincture of oak-bark, and 2 gallons of Rochelle brandy for each barrel.

Preparation of Monongahela, Bourbon, Irish, and Scotch Whisky, or Rye, Corn, Wheat, and Barley Whisky.—In different countries, various grains are employed for the production of whisky. The rye is much used in Holland, the potato in Germany, the barley and oats in Ireland and Scotland, and corn in the United States.

(1.) The Monongahela whisky is mostly distilled in the western country from rye. In order to convert a corn whisky into a rye whisky, add to 4 barrels of the corn whisky—

1 pound of the essence of Monongahela,
 1 ounce of sweet spirits of nitre,
 1 gallon of syrup of gum-arabic.

(2.) The Bourbon whisky is best imitated by—

1 pound of the essence of Bourbon,
 1 ounce of sweet spirits of nitre,
 1 gallon of syrup,
 4 barrels of common rectified corn whisky.

(3.) The Irish whisky, which is characterized by its smoky flavor and taste, on account of its being prepared from barley peculiarly treated with the peat while malting, is best imitated by

1 pound of the essence of Irish whisky,
 1 ounce of sweet spirits of nitre,
 $\frac{1}{2}$ gallon of syrup of gum-arabic,
 4 barrels of good whisky, from either rye or corn.

(4.) The Scotch whisky, which has a marked and different taste from the Irish whisky, probably owing to a different mixture of the grain, such as the barley and oats and wheat in various proportions, but, from a similar mode of preparation of the malt, having the same smoky taste, is prepared likewise by—

1 pound of the essence of Scotch whisky,
 1 ounce of sweet spirits of nitre,
 $\frac{1}{2}$ gallon of syrup of gum-arabic,
 4 barrels of common whisky.

All the whiskies ought to be laid aside for four to six weeks before being put into the market for sale.

§ XLI.

II. *Compound Liquors.*—A great many liquors belong to this class, and the best spirit is necessary to produce a good imitation. The first, and most important liquor, is *gin*, which is a favorite drink in Holland, and is imported to this country in very large quantities. In Holland, the process of

manufacturing gin is to mash the malt barley and rye meal together; it is then fermented and distilled; afterwards this spirit is rectified by adding some juniper-berries and a small quantity of hops, and the product of the rectification is a high-flavored gin. In order to imitate Holland gin, as well as English or London gin, and also Tom gin, it is the best juniper oil which must be employed—that from the berry, and not from the wood. The essences of gin, and the gin-flavorings, are the materials used for producing this pleasant and wholesome beverage.

1. To prepare Holland gin from the oil, take

- 2½ ounces of the best juniper oil,
- 20 drops of oil of lemon,
- 15 “ of oil of coriander.

Dissolve the oils in 2 quarts of high-proof alcohol, and let it stand over-night; then put them in a forty-gallon barrel containing pure spirits, and 1 gallon of syrup of gum arabic.

2. London cordial gin, from the oil, is prepared likewise from

- 2½ ounces of oil of juniper-berry,
- 20 drops of oil of calamus,
- 10 “ of oil of angelica,
- 5 “ of oil of coriander,

dissolved in 2 quarts of 95 per cent. alcohol, 40 gallons of pure spirits, and 2 gallons of syrup of gum arabic.

Should the liquor be milky, it is necessary to filter it, which is done by letting it run through a woollen filtering bag, in which is contained a mixture of

- 4 ounces of burnt alum,
- 6 “ of white pipeclay,
- 4 “ of carbonate of magnesia,
- ½ “ of dry pearl-ashes.

This compound is suitable for all those liquors which have become milky by the addition of any essential oil to weak spirits. It is always necessary to pour the filtered alcohol,

in small quantities, into the barrel containing the pure spirits, and to shake the barrel every time a fresh portion of the same is added; then the gin will remain clear—otherwise it will become milky again, and occasion much trouble and difficulty to filter forty gallons of gin through the bag.

In order, however, to avoid the trouble of filtering, the gin-flavorings may be employed for the purpose; and one gallon of the flavorings, thrown into a barrel containing from forty to forty-five gallons of pure spirits, will produce a clear gin, and answer all the requirements of Holland, or English gin.

§ XLII.

The following liquors belong to this class, viz.: peach, cherry, apple or cider brandies; blackberry, raspberry, plum, orange, cinnamon, ginger, clove, peppermint, pear, banana, pineapple, vanilla, kimmel or caraway, and anise liquors; stomach bitters, wormwood, Blake's, Hoofland's, Stoughton's, a new *aqua vitæ* or tonic bitters, and Boerhaave bitters. Particularly, however, Jamaica and New England rum, extract of punch, and extract Bishop.

1. *Jamaica Rum*.—This may be produced from the rectified spirits, by employing

- 1 pound of the essence of rum,
- 1 ounce of oil of pimento,
- 1 “ of tincture of orris root,
- $\frac{1}{2}$ “ of Peruvian balsam.

Dissolve the oils separately, and then mix them with the essence, and throw them in a cask containing 160 gallons of pure spirits. Or by the Jamaica rum flavorings; of which 1 gallon, added to a barrel of pure spirits, will produce an excellent rum.

2. *New England Rum*.—This is generally prepared in the Eastern States by the distillation of molasses; but frequently this material is not so plentiful, and resort is had to the com-

mon corn whisky, which is once more rectified, and by adding 1 pound of strong essence of Jamaica rum, and 1 pound of nitrous ether, to 10 barrels of such purified corn spirits, a good New England rum is obtained.

3. *Peach Brandy*.—This beverage is prepared from the essence of peach, by taking

- 1 pound of the essence,
- 1 gallon of syrup of gum arabic,
- 1 ounce of acetic ether,
- 1 “ of pineapple ether,
- 4 barrels of pure spirits.

4. *Apple or Cider Brandy*.—It is prepared by using

- 1 pound of the oil of apple,
- $\frac{1}{2}$ “ of the oil of pear,
- 1 gallon of syrup of gum arabic,
- 5 barrels of good rectified spirits.

5. *Cherry Brandy*.

- 1 pound of the essence of cherry,
- $\frac{1}{4}$ “ of the essence of pineapple,
- $\frac{1}{4}$ ounce of the oil of cinnamon,
- $\frac{1}{4}$ “ of the oil of cloves,
- 4 barrels of pure rectified spirits,
- 2 gallons of cherry juice.

6. *Blackberry Brandy*.—This liquor is prepared from

- 1 pound of the essence of blackberry,
- 1 gallon of blackberry juice,
- 1 “ of syrup of gum arabic,
- 4 barrels of pure spirits.

7. *Raspberry Brandy*.

- 1 pound of the essence of raspberry,
- 1 “ of acetic acid,
- 1 gallon of syrup of gum arabic,
- 1 “ of raspberry juice,
- 4 barrels of pure spirits.

8. *Plum or Zwetschen Brandy*.—This favorite German liquor, also called Slibowitz liquor, is prepared from

- 1 pound of plum essence,
- $\frac{1}{2}$ " of acetic ether,
- $\frac{1}{2}$ " of banana,
- 1 gallon of syrup of gum arabic,
- 4 " of pure spirits.

Another mode of preparing the slibowitz or plum brandy is from prunes, which are mashed together with the kernels, and exposed to fermentation, when it is again distilled, and produces a fine spirit, having the flavor and taste of prussic acid.

9. *Orange Brandy*.

- 2 ounces of oil of orange,
- 10 drops of oil of neroli,
- 1 pound of essence of orange,
- 1 gallon of syrup of gum arabic,
- 4 barrels of pure spirits.

10. *Cinnamon Brandy*.

- 1 pound of the essence of cinnamon,
- $\frac{1}{2}$ " of the essence of cherry,
- 1 gallon of syrup of gum arabic,
- 4 barrels of pure spirits.

11. *Ginger Brandy*.

- 1 pound of essence of ginger,
- 20 drops of oil of bergamot,
- $\frac{1}{4}$ pound of tartaric acid,
- 1 gallon of elderberry juice,
- 1 " of syrup of gum arabic,
- 4 barrels of pure spirits.

12. *Clove Brandy*.

- 1 pound of the essence of cloves,
- $\frac{1}{2}$ " " cherry,
- $\frac{1}{4}$ " " ginger,

1 gallon of syrup of gum-arabic,
4 barrels of pure spirit.

13. *Peppermint Liquor.*

1 pound of the essence of peppermint,
 $\frac{1}{4}$ " sulphuric ether,
1 gallon of syrup of gum-arabic.
2 barrels of pure spirit.

14. *Pear Brandy.*

15. *Banana Brandy.*

16. *Pineapple Brandy.*

17. *Vanilla Brandy.*

All these liquors are used in the mixtures for highly flavored and pleasant brandies by the addition of some syrup.

18. *Kimmel.*

1 pound of the essence of caraway,
 $\frac{1}{4}$ of an ounce of oil of anise,
 $\frac{1}{4}$ " " fennel,
20 drops " neroli,
1 gallon of syrup of gum-arabic,
2 barrels of pure spirits.

19. *Annis Liquor* is prepared from

1 pound of the essence of anise,
 $\frac{1}{4}$ " tincture of orris,
20 drops of the oil of coriander,
2 barrels of pure spirits.

20. *Wormwood Liquor.*

1 pound of the essence of wormwood,
1 ounce of the oil of tansy,
1 " " calamus,
2 " " orris,
1 gallon of the syrup of gum arabic,
3 barrels of pure spirits.

21. *Stomachic Bitters.*

All the bitter liquors, so called, stomachic, tonic, aromatic,

Phoenix, Stoughton's, Blake's, Boerhaave's, and other bitters, are mostly composed of gentian-root, orange-peel, centaury-flowers, chamomile flowers, calamus-root, and coriander-seed, with more or less variation of the ingredients, and an addition of more spices, such as cloves and mace; some also add hops and quassia-wood, in order to make a very strong bitters. The bitters of Blake and Boerhaave contain a small portion of aloes, and that of Hostetter more centaury flowers. The best materials for preparing a wholesome bitters, which will excite an appetite and act upon the liver and digestive organs, is to put in a barrel containing 40 gallons of pure spirits,

$\frac{1}{4}$	pound of gentian-root,
$\frac{1}{4}$	“ orange-peel,
$\frac{1}{2}$	“ “ buds,
$\frac{1}{4}$	“ agaric,
$\frac{1}{4}$	“ chamomile-flowers,
$\frac{1}{4}$	“ centaury “
$\frac{1}{4}$	“ coriander-seed.

These ingredients are all bruised together and left in maceration for a fortnight, in a warm temperature; after the lapse of that time the clear bitter liquor is drawn off and mixed with an equal quantity of water, so as to make the bitters palatable. One gallon of such a stomachic or tonic bitters will not cost more than 25 cents.

23. *Extract Punch.*

$\frac{1}{2}$	ounce of the essence of Jamaica rum,
1	“ tartaric acid,
1	gallon of sugar syrup,
2	“ pure spirits,
	10 drops of the oil of lemon.

Dissolve the oil of lemon and essence of rum in the spirits, and the tartaric acid in a little water, before adding all together.

25. *Extract Bishop or Glow-wine.*

Take of the tincture of Curaçao-peel 1 pound,
 " " orange-buds $\frac{1}{4}$ "
 Dissolve in the same 5 drops of the oil of nutmeg,
 10 " " cloves,
 20 " " cinnamon.

Mix them together, and add about half a gallon of the sugar syrup.

§ XLIII.—CORDIALS.

These liquors are compounds of the best spirits, in which the various flavors or essences are dissolved, with more or less of the syrup made from white sugar. The following are the principal cordials in general consumption, viz.: the absinthe, Curaçao, Maraschino, anisette, perfect love, cherry-bounce, raspberry, and the railroad liqueur, a new cordial composed by myself; also the elixir vitæ or long-life cordial, orange elixir, Roman punch, and kirschwasser.

1. *The Absinthe.*—This liqueur is prepared in various ways. Originally prepared in Switzerland, it has acquired great celebrity, and is therefore frequently called Swiss absinthe; but at present in France it is likewise made of a superior quality. The genuine Swiss absinthe is prepared in the following manner: by macerating

4 ounces of the wormwood herb,
 2 " star anise-seed,
 2 " green cherry-leaves,
 2 " sage herb,

in 5 gallons of proof spirits; and after one week's maceration add

$\frac{1}{4}$ ounce of the oil of anise,
 $\frac{1}{2}$ " " bergamot,
 $\frac{1}{4}$ " " fennel.

Another receipt for making the absinthe is, to dissolve the

best oil of wormwood, say 2 ounces, in 5 gallons of pure spirits, and add

$\frac{1}{2}$ ounce of the oil of anise,
 $\frac{1}{4}$ " " calamus,
 $\frac{1}{4}$ " " orange,
 1 gallon of white syrup,

and prepare the color from the neutral extract of indigo, made green with the tincture of Turmeric.

2. *The Curaçao*.—This liqueur derives its name from the Curaçao-peel, as it is nothing else but a tincture of the Curaçao orange-peel, sweetened and flavored with more essential oils. The following receipt is the most reliable: to macerate 5 pounds of green Curaçao orange-peel in 6 gallons of pure spirits, adding about $\frac{1}{4}$ of a pound of red saunders wood for obtaining at the same time the reddish brown color; and after a week's digestion strain off, and dissolve $\frac{1}{4}$ of an ounce of oil of bitter-almonds, $\frac{1}{4}$ of an ounce of oil of cinnamon in the above tincture, and then add 1 gallon of white sugar syrup: when all ingredients are mixed, filter and fill in bottles, and after standing a few weeks it will produce a delightful cordial.

3. *Maraschino*.—This is an Italian cordial, while the Curaçao is a favorite in Holland. Maraschino derives its aroma from the oil of bitter almonds, blended with the oils of cinnamon and rosewater, &c.

10 gallons of pure spirits,
 1 ounce of oil of bitter almonds,
 $\frac{1}{2}$ " " cinnamon,
 $\frac{1}{4}$ " " cloves,
 $\frac{1}{4}$ " " vanilla,
 5 drops of oil of rose,
 5 " " neroli,
 5 " " bergamot.

To this solution add 2 gallons of white-sugar syrup, $\frac{1}{4}$ gallon

of rosewater, and $\frac{1}{4}$ gallon of orange-flower water; mix together, and filter, and fill in bottles.

4. *Anisette*.—Dissolve 2 ounces of oil of anise and $\frac{1}{2}$ an ounce of oil of star anise in 10 gallons of pure spirit, and add 2 gallons of white-sugar syrup to it.

5. *Parfait d'amour, or Perfect-love Cordial*.—Macerate in 10 gallons of pure spirit,

2 ounces of orris-root,
4 " of raisins,
2 " of figs,

For one week. Then dissolve

$\frac{1}{4}$ ounce of oil of lemon,
1 drachm of oil of cinnamon.
1 " " juniper,
1 " " calamus,
1 " " cloves,
1 ounce " vanilla.

Color by sugar-coloring, and add 4 gallons of white-sugar syrup: it is then filtered through a woollen filtering-bag, and filled in bottles.

6. *Cherry-bounce*.—This is a very wholesome cordial, and may, with great benefit, be taken by persons affected with cough of long standing, or those suffering with lung complaint. Take

5 gallons of cherry-juice,
2 " of syrup of white sugar.

And dissolve in 1 gallon of pure spirit—

$\frac{1}{2}$ ounce of oil of bitter almonds,
 $\frac{1}{4}$ " " cloves,
 $\frac{1}{4}$ " " cinnamon.

Mix all together.

7. *Raspberry Cordial*.—Take 5 gallons of raspberry-juice, 2 gallons of white-sugar syrup, and 1 gallon of pure spirits.

The quince, gooseberry, strawberry, black and red cur-

rant, peach, nut, and apple cordials, are all prepared in the same manner from their respective juices.

8. *The Railroad Liquor*.—To 5 gallons of pure spirits, add

$\frac{1}{4}$ ounce of oil of peppermint,
 $\frac{1}{4}$ “ “ absinthe,
 10 drops “ rose.

Add to the solution 1 gallon of white syrup, and color the liquor with blue orchil.

9. *Elixir Vitæ, or Long-life Cordial*.—Macerate for ten days, in 5 gallons of pure spirits,

1 ounce of zedoary-root,
 1 “ of ginger-root,
 $\frac{1}{2}$ “ of gentian-root,
 $\frac{1}{2}$ “ of agaric,
 $\frac{1}{4}$ “ of rhubarb-root.

Strain off the clear tincture, and add $2\frac{1}{2}$ gallons of water and $\frac{1}{2}$ gallon of syrup.

10. *Orange Elixir*.—To 5 gallons of pure spirits, add

$\frac{1}{2}$ pound of orange-peel,
 $\frac{1}{4}$ “ of calamus-root,
 $\frac{1}{4}$ “ of hops.

After macerating for one week, strain, and add 1 gallon of sugar-syrup, and color with sugar-coloring.

Also another receipt for the above; which is, to dissolve in 3 gallons of pure spirits

1 ounce of oil of orange,
 $\frac{1}{4}$ “ “ calamus,

and add 1 gallon of white-sugar syrup, and color the whole with sugar-coloring.

11. *The Roman Punch*.—This very refreshing beverage is prepared by 1 ounce of lemon-juice or citric acid, $\frac{1}{2}$ ounce of essence of rum, dissolved in 1 gallon of pure spirit, adding $\frac{1}{2}$ gallon of syrup of sugar. Mix all together, and filter.

12. *Kirschwasser*.—Dissolve 1 ounce of the oil of bitter

almonds in 3 gallons of pure spirits, and add 1 gallon of white-sugar syrup.

13. *Noyeau*.—This cordial is generally drunk by ladies, and requires to be very sweet. Take

1 ounce of oil of bitter almonds,
 $\frac{1}{2}$ " " orange,
 $\frac{1}{4}$ " " cinnamon.

Dissolve in 2 gallons of pure spirits, and add 1 gallon of syrup of white sugar.

14. *Orgeat*.—To milk of blanched sweet almonds, 2 pounds, add

2 drachms of oil of bitter almonds,
 1 " " orange,
 1 gallon of white-sugar syrup,
 $\frac{1}{2}$ " of spirits.

15. *Peppermint Cordial*.—To 1 ounce of oil of peppermint dissolved in 1 gallon of pure spirit, add 1 gallon of syrup of white sugar.

16. *Ginger Cordial*.—To 1 quart of essence of ginger add 1 gallon of pure spirit and 1 gallon of white-sugar syrup.

17.—*Angelica Cordial*.—To 1 ounce of oil of angelica add $\frac{1}{4}$ ounce of calamus, and dissolve them in 1 gallon of pure spirit, and add 1 gallon of white-sugar syrup.

18. *Celery Cordial*.—To 1 pound of the essence of celery, add 1 gallon of pure spirit and 1 gallon of syrup of white sugar.

19. *Rose Cordial*.—To $\frac{1}{2}$ ounce of otto of rose add $\frac{1}{4}$ ounce of oil of bitter almonds. Dissolve in 1 gallon of highest-proof alcohol, and add 1 gallon of syrup of white sugar, and color by cochineal rose color.

20. *Nectar Cordial*.

1 ounce of oil of bitter almonds,
 $\frac{1}{2}$ " " orange,
 $\frac{1}{2}$ " " cloves.

Dissolve them in 1 gallon of pure spirits, and add 1 gallon of white-sugar syrup and 2 gallons of Teneriffe wine.

21. *Aromatic Wine-bitters.*—Macerate

1	pound	of orange-peel,
2	"	of orange-buds,
$\frac{1}{2}$	"	of agaric,
$\frac{1}{2}$	"	of Peruvian bark,
1	"	of gentian-root,
5	gallons	of Teneriffe wine,
20	"	of spirits of wine.

CHAPTER XIII.

XLV.—ON ACETIC ACID, VINEGAR, QUICK-VINEGAR, &c.

1. It has been stated in the beginning of this Treatise, that, besides the alcoholic or vinous fermentation, there is an acetous fermentation, which manifests itself in the same substances that have first undergone the vinous fermentation, and merely depending upon oxydation of the same substances by atmospheric air; and that the transition from the vinous to the acetous fermentation of many substances is so rapid, and in some instances instantaneous, that the theory of this sudden change has, for a long time, been a mystery to the inquiring chemist. It is, however, fully ascertained, that pure alcohol, whisky, all expressed juices of fruits and grains, after undergoing the first change, may, by prolonged fermentation, be again metamorphosed, and become sour, and the product is then called acetic acid or vinegar.

2. The change produced by the conversion of alcohol into acetic acid, has been ascribed by Berzelius to a force which he called Catalysis, meaning the absorption and condensation of air; and it is not improbable that the ferment absorbs oxygen, and resolves itself into a highly oxydized body, which, by giving up a portion of oxygen to the alcohol, evolves carbonic acid and water. It is also proved that, where the ferment has been decomposed and precipitated as insoluble matter after a long-continued vinous fermentation, as is the case in some wines and in the low fermentation of Bavarian beer, these liquids lose the tendency to acetification.

When vinous liquors are exposed to the free access of at-

mospheric air, at a temperature of 80° , they undergo this second fermentation, and terminate in the production of a sour liquid called Vinegar. Vinegar is obtained from a great many substances. In England, it is made from malt liquor; in France, where the grape is in abundance, it is produced from wine. Vinegar has a variable specific gravity, but is never higher than 1.0250. Vinegar may become mouldy, or advance farther into another fermentation, called the putrid fermentation, when exposed too long to the atmospheric air.

3. Distilled vinegar, or dilute acetic acid, is distilled over from common vinegar. It becomes higher in its specific gravity, for it rises from 0.997 to 1.020; and one fluidounce of the same will neutralize eight grains of precipitated chalk. Distilled vinegar is colorless, and has a flat acid taste, and consists essentially of the real acetic acid, which is sometimes called the radical vinegar, and water. Acetic acid is produced also from the distillation of a metallic salt, called Verdigris (acetate of copper), or by distilling acetate of soda, or acetate of lead (sugar of lead), with half its weight of sulphuric acid, or from a mixture of sulphate of copper and acetate of lead.

4. The principal quantity of acetic acid is at present obtained by the distillation of wood in the process of preparing charcoal for the manufacture of gunpowder, or for other technical purposes, and the liquor which first distils over is called Pyroligneous Acid. It is very empyreumatic and impure, and requires to be freed from tar and other substances.

The pyroligneous acid is saturated with chalk and then evaporated, by which an impure acetate of lime is obtained, which, mixed with sulphate of soda, furnishes, by double decomposition, sulphate of lime and acetate of soda. This latter, distilled with sulphuric acid, produces a sufficiently pure acetic acid, and is generally sold as acetic acid No. 8 in the

market, and has a specific gravity of 1.060; when crystallized, at a temperature of 40°, it is called glacial acetic acid.

§ XLVI.

5. As my object is to describe practically the vinegar made by the quick process, so that any person may be able to construct an apparatus at a trifling cost, and can make his own table vinegar for about three cents per gallon, and be equal to the French wine vinegar; I will, therefore, detail minutely the process, which I have described, in the year 1837, in Siliman's American Journal of Science, Vol. xxxi. p. 272, with a drawing. The apparatus described in Booth's Encyclopaedia, p. 19, is, however, of simple construction, and it is now here copied.

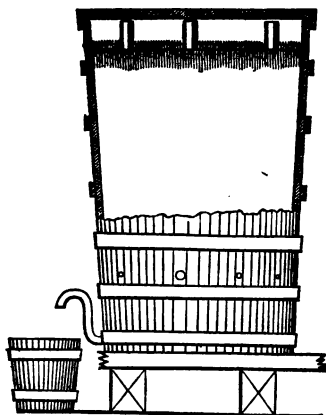

The oaken vat or vats in which the oxydation of the alcohol takes place, are called vinegar generators, or graduators, and are 5 to 7 feet high, 3½ feet diameter below, 3 feet wide above, placed 1½ feet above the ground, and provided with a wooden cover, fitting rather closely, and having a funnel inserted in its centre, through which the alcoholic liquid is to

be poured. A broad wooden hoop is fastened closely around the inside, about six inches from the top, on which rests the false top, leaving a small square between it and the sides, to be stopped tightly with tow. This is perforated with 200 to 300 small holes, of one-sixth of an inch diameter and $2\frac{1}{2}$ inches apart, through each of which pass strips of cotton or linen wick, with knots on the upper end to prevent their passing through; four larger holes, $1\frac{1}{2}$ inches in diameter and $1\frac{1}{2}$ feet apart, are each fitted air-tight with a glass-tube four to five inches long, which, opening a little below, and several inches above the false top, allows the air of the interior to pass out slowly. About one foot or fifteen inches from the bottom, eight holes are bored, sloping downwards, at equal distances, in a circle around the vat, through which the air enters, without suffering the liquid to flow out. The whole vat is then filled with beech-wood shavings to within an inch of the false top: they should be previously scalded with water and soaked in hot vinegar. The liquid is poured into the vat through the funnel, and trickles drop by drop through the cotton-wick. To prevent its running too fast, the wicks should fill the holes, and the false top fit closely to the sides; spreading among the shavings, it offers a very extended surface to the action of the air entering through the eight holes, and is more or less oxydized. The air, having performed its part, pushes out through the four glass-tubes, and finally through the funnel in the cover. To prevent the liquid from collecting in too great quantity at the bottom, a glass siphon is introduced an inch or two from the bottom, so that its upper head is an inch at least below the eight holes, and runs off the liquid into the receiving vessel or bucket. A thermometer is sometimes introduced a little below the false top, to observe the temperature of the oxydating compartment of the vat.

To charge the vats a standard liquid is employed: 50

gallons of 60 per cent. alcohol or whisky, and 87 gallons of beer or other fermented liquor. When the vats are first put in operation, acetification takes place slowly, until the shavings are well charged with mother of vinegar; to attain which, 5 gallons of the above are mixed with 40–50 gallons of weak vinegar, and poured through the funnel into the upper part of the vat, from which it passes gradually through the shavings, and the alcohol is partially oxydized; it is then poured repeatedly through the same vat, until it comes through completely acetified. A deposit of mother gradually takes place on the shavings and side of the vat, and the larger the amount of it formed, the more rapid the oxydation; so that the process goes on better after some weeks than at first.

The vats being thus prepared, 15–18 gallons of the above standard liquor is diluted with 60 gallons of soft water, and poured into the first vat, then into the second; every hour $2\frac{1}{2}$ gallons are drawn off from the second: the product of one hour being kept as vinegar, that of the next hour being thrown back on the first vat: thus in 24 hours 30 gallons are ready for sale. With ten vats, which one hand can superintend, 150 gallons of acetic acid may be made in 17 working hours.

This acetic acid is as clear as water, and may be improved in appearance and taste by adding to every 52 gallons 1 pound of cream of tartar and 2 pounds of sugar. The temperature of the vinegar-room should be about 100° , and the preparatory mixture to be from 120° to 130° when poured through. When the vats are in full operation, the temperature in the vinegar-room should be maintained at 68° to 71° . If a stronger vinegar is required, the product of the second vat is mixed with a stronger alcoholic liquid and passed through a third vat; and for a still stronger, a fourth vat is employed, with the addition of proof spirit to the product of the third; but it should be noted, that the weaker

spirituous liquors are more easily and rapidly acetified than the stronger.

The vinegar obtained by the above preparation is of such strength, that an ounce will neutralize 30-36 grains of carbonate of potassa, and the product of the fourth vat will neutralize 50-60 grains of carbonate of potassa.

XLIV.—THE LATEST IMPROVEMENT IN QUICK VINEGAR PROCESS.

6. A still more simple apparatus for producing a good vinegar in the space of 12-24 hours without the increased temperature is now introduced, and is constructed in the following manner :

A large cask, about 12-15 feet high and 5-10 feet wide, without air-holes, but cover closely fitting on the cask, is filled with beech wood or with charcoal in large lumps, or even with cotton, or any other porous substance : both these substances, as well as the cask, are properly acetified by strong acetic acid, and drawn off by means of a cock near the bottom ; and then the mixture of alcohol or strong whisky, 1 part to 10 parts of water, filled into the cask, and after a lapse of 12 hours poured off as good vinegar. This vinegar is produced in a common temperature ; but the liquid which is the ready-prepared vinegar, must run slowly, and the quantity of the mixture of 1 part of alcohol to 10 parts of water, must be poured in at proper intervals. The product obtained by this process is much stronger and much quicker, and, although requiring more attention to time of filling, yet is very easily managed. This vinegar may be made to keep longer by adding a few pounds of sugar to it.

7. This vinegar may be prepared in any house or hospital at a cost not exceeding five cents per gallon, and of any desired strength ; and if the vinegar be made on a small scale, a glass cylinder may be employed instead of an oak

vat, and the charcoal in lumps thoroughly impregnated with acetic acid, and the cover tightly fitted on the glass cylinder, and a stop-cock applied at the bottom so as to draw off the prepared vinegar.

8. *The French Wine-vinegar* is prepared in France on a large scale, where they employ three or four rows of vats, holding 45 gallons each, and lying horizontally, with two holes adjoining in the upper part of the front end, one of which, two inches in diameter, is for charging the cask with wine and removing the finished vinegar; the other, which is much smaller, is designed for the influx and efflux of the atmospheric air. When the casks are first employed, they are one-third filled with the best wine-vinegar, to which two and a half gallons of wine are added; in eight days a second charge of two and a half gallons is introduced, and thus a third and a fourth, after intervals of eight days each, until the proper quantity has been added, or the casks are two-thirds full. Eight days after the last charge, about nine gallons of vinegar are drawn off, provided the fermentation has been successful, and wine added in the same quantities and time as before. Under favorable circumstances, one of these stand-casks will last for twenty years.

9. *Apple Vinegar*, also the juice of grapes and other saccharine fruits, is obtained by expressing and subjecting to vinous fermentation in casks at a temperature of 77–82°; if muddy, they have to be filtered through beech-wood shavings, &c., to clarify, and then suffered to acetify in vinegar-casks, adding a little vinegar to commence and hasten the operation.

Vinegar from starch and potatoes may be obtained in the usual way, by boiling either, and exposing them at first to vinous, and then to acetous fermentation.

10. *Vinegar from Beer*.—To 100 gallons add an equal quantity of water, 3 gallons of alcohol, and 6 gallons of

strong vinegar; put the whole in the vinegar-cask at a warm temperature.

Vinegar may also be made from rice, by first exposing it to the vinous fermentation, as stated in a former chapter of the conversion of starch into starch sugar, by means of oil of vitriol, and then subjecting the saccharine solution to the rotating fermentations.

11. *Raspberry Vinegar* and *Strawberry Vinegar*.—These are prepared by mixing 1 pound of the respective fresh juices with 4 gallons of good boiled vinegar, and setting aside for one or two days, and then filtering off the clear liquor; put then in bottles well corked, and bladder tied over them.

Both these vinegars may be used as salad, or mixed with sugar and water as a summer beverage, and are quite cooling and wholesome.

12. *Forty Thieves Vinegar* or *Aromatic Vinegar*.—Macerate cloves, sage, rosemary, rue, pimento, calamus, caraway, nutmegs, each 1 ounce, in 2 gallons of strong vinegar, and add one-half ounce of camphor.

This vinegar is usefully employed in infectious diseases, and has received the above name from the circumstance, that at Marseilles, where the pestilence once raged, the thieves, who used this vinegar, pillaged the city, and were not attacked by the disease.

CHAPTER XIV.

§ XLVII.—THE ADULTERATION OF FERMENTED LIQUORS.

It is well known that in England many drugs are used for giving beer strength. 1. *Cocculus indicus*, grains of paradise, sweet flag root, and tobacco leaves are used there for accomplishing their aim. 2. Sulphuric acid is also used to bring beer forward—that is, giving new beer instantly the taste of what is eighteen months old. Quassia, aloes, extract of gentian, capsicum, and ginger-roots are likewise used for sophistication. Sulphate of iron, alum, and salt are used also for giving the beer a heading—that, is, to impart a frothing property. Extract of liquorice for coloring and sweetening. 3. The *Ledum palustre* and *Ledum latifolia* are used in Germany for similar purposes, and the seeds of the *datura stramonium* are used in Russia. To grape-wine, poppy-heads are added in Persia. In ancient Palestine, frankincense was added, especially to wine given to criminals, for the purpose of stupefying them before their execution. In ancient Greece, sea-water (1 of sea-water to 50 of wine) was employed, with the view of aiding digestion, and preventing its affecting the head. Quassia wood and aloes are frequently put in beer in this country, to impart a bitter taste. Irish moss is used among brewers for giving the beer a body, or heading; Iceland moss, for imparting a bitter taste.

CHAPTER XV.

BAR-ROOM DRINKS OR BEVERAGES.

Mint Julep.—To equal quantities of rum, cognac, and sugar, add fresh mint herb, and fill the glass half full with gin and water.

Hippocras.—To 4 bottles of good Rhine wine, add 1 pound of fine white sugar, a few grains of white pepper, 1 ounce of ground cinnamon, and the rind of a lemon—this is left for twenty-four hours; a little vanilla, rubbed up with sugar, is put in a fine linen bag, through which the wine is filtered, and 12 apples, cut in slices, are put into the bowl containing the whole.

Bishop.—To 1 bottle of fine medoc or Burgundy, put the rind of an orange, which is left to digest a few hours, and then add 2 ounces of sugar.

Pope.—The best Hungarian wine is used, instead of red wine.

Cardinal.—The best old Rhine wine is used, instead of claret.—To make Cardinal from fresh fruit, take

- 2 bottles of old Rhine wine,
- 1 pineapple cut in slices,
- 1 bottle of champagne,
- 1 dozen fresh peaches, cut up.

Whist.—The juice of 6 lemons is squeezed into an infusion of green tea and sugar, then add 6 bottles of medoc, and heat, without boiling: it is drunk while hot.

- Sillibub*.— $1\frac{1}{2}$ bottles of Rhine wine,
 $1\frac{1}{2}$ " of cream of milk,
 1 pound of sugar,
 8 lemons, cut up and pressed.

It is then stirred with a muddler until all is turned to froth, when it is drank.

Kneebend.—To 1 wine-glass of Curaçoa, put the yellow of an egg; then add a few drops of maraschino, and drink at one draught.

Flip.—To $\frac{1}{2}$ of a gallon of white beer (Berlin), add $\frac{1}{4}$ of a pound of sugar, 1 drachm of fine cinnamon, a few cloves, a little ginger, 1 pint of Jamaica rum, and 4 eggs, the yellow of which is muddled. The beer, spices, yellow of the eggs, and rum are heated and well stirred together; they are then added to the first and drank hot.

Grog.—To 1 bottle of arac, Jamaica rum, or cognac brandy, add $\frac{1}{2}$ pound of sugar, dissolved in boiling water, and a few drops of tincture of vanilla.

Contentment.—Boil $\frac{1}{2}$ a pound of sweet almonds, peeled and powdered, in 1 pint of milk; strain, and add lemon-peel, cinnamon, sugar, and the yellow of 4 eggs.

Glow-wine.—Stir 4 eggs with 4 bottles of Rhine wine and $\frac{1}{4}$ of a pound of sugar, and add cinnamon and cloves; make it hot, and, after muddling the mixture to a thick froth, it is drank hot.

Necos or Negus.

- 4 bottles of good Rhine wine,
- 1 “ of water,
- $\frac{1}{2}$ ounce of cinnamon in lump,
- $\frac{1}{2}$ drachm of cloves,
- $\frac{1}{2}$ “ of cardamoms,
- $\frac{1}{2}$ “ of mace,
- 1 pound of sugar;

Add the juice and rinds of 2 lemons, boil all together, and drink while hot.

Punch, cold.—To 2 pounds of sugar and pressed lemon-juice of 6 lemons, add 3 bottles of Rhine wine, 1 bottle of Burgundy, and 2 bottles of arac or Jamaica rum.

Punch, hot.—Boil $1\frac{1}{2}$ pounds of sugar, and 3 lemons, with their juice, in 3 bottles of water; then add $1\frac{1}{2}$ bottles of Jamaica rum and 1 bottle of Rhine wine; it must then be left a little while to mix together. Some add a little green tea.

Royal Punch.—To $1\frac{1}{2}$ pounds of sugar, 1 bottle of water, a little drawn green tea, and the juice of 4 lemons, strained, add

1 bottle of Burgundy,
1 “ of arac,
1 “ of old Rhine,
1 “ of champagne,
1 small bottle of maraschino.

Egg Punch.—For six persons, take the yellow of 24 eggs, stir to froth with cold water; add 1 pound of sugar, and the juice of 6 lemons, dissolved in $\frac{1}{2}$ a gallon of hot water; then add $1\frac{1}{2}$ bottles of the best rum.

Punch à la Glace.—To $1\frac{1}{2}$ pounds of sugar, dissolved in water, add the juice of 6 lemons, 2 bottles of champagne, and 1 bottle of arac, which is put on ice until nearly congealed.

Champagne Powder.—To convert any wine, at a moment's notice, into champagne, take the dry powders of

30 grains of bicarbonate of soda,
20 “ of tartaric acid,
2 ounces of white sugar.

This powder is thrown into a strong champagne-bottle, and at once corked; the bottle is then turned up, and in a minute afterwards it may be drunk as champagne.

Champagne Mixture.—This tincture is prepared from 1 gallon of must wine, 1 pound of white sugar, and a little alcohol. One glass-full of this tincture will convert a bottle of any young wine into champagne.

English Champagne.—Take 10 pounds of gooseberry-juice and 1 gallon of water; after three days, press, and add $3\frac{1}{2}$ pounds of sugar to 10 pounds of the juice; let the whole

stand for five or six weeks, and take off the scum occasionally; then fill it in bottles, after adding a small quantity of brandy to it.

Currant Champagne.—Boil up the pure currant-juice to a syrup consistency, and preserve in well-corked bottles for use; by adding a cup-full of this currant-syrup to $\frac{1}{2}$ a gallon of French wine, and stirring them up together, a very good champagne is obtained—not inferior to any other.

Rhubarb Champagne.—The juice of fresh rhubarb-plant is left to ferment with sugar, and produces a high-flavored champagne.

PART II.

HYGEINE, OR TREATISE ON HEALTH.

CHAPTER I.

DISEASES: REMEDIES AND TREATMENT IN MEDICAL CASES.

As, most generally, the doses in the following pages are intended for adults, it is necessary to indicate the proportionate doses to be administered to younger persons: and I will now state that the apothecary's weight differs from the common weight; also that one fluid drachm is equal to a teaspoonful, or 60 minims or drops; 1 dessert-spoonful is equal to $\frac{1}{4}$ ounce, or 2 fluid drachms;

1 tablespoonful is = 4 fluid drachms, or $\frac{1}{2}$ ounce,

2 tablespoonfuls = 8 " " or 1 "

1 wineglassful = 16 " " or 2 ounces,

1 tablespoonful of syrup = 5 drachms,

1 " of distilled water = $3\frac{1}{2}$ drachms,

1 dessert-spoonful " " = 1 drachm,

1 teaspoonful of syrup = 1 to 2 drachms,

1 " of tincture, about 20 grains,

1 " of magnesia, " "

1 " of sulphur, " 2 scruples (40 grains),

1 teacupful is = 4 ounces,

1 wineglassful = $1\frac{1}{2}$ "

The proportionate doses—if one drachm be given to persons of twenty-one years of age—are :

For persons of 14 years of age,	$\frac{2}{3}$,	or 2 scruples,
“ “ 7 “ “	$\frac{1}{2}$,	or half a drachm,
“ “ 5 “ “	$\frac{1}{3}$,	or 1 scruple,
“ “ $3\frac{1}{2}$ “ “	$\frac{1}{4}$,	or 15 grains,
“ “ $2\frac{1}{3}$ (28 months)	$\frac{1}{5}$,	or 12 “
“ “ $1\frac{1}{8}$ (14 months)	$\frac{1}{8}$,	or 8 “
“ “ $\frac{7}{12}$ (7 months)	$\frac{1}{12}$,	or 5 “
“ “ 7 weeks,	$\frac{1}{15}$,	or 4 “

PROPERTIES OF THE PRINCIPAL MEDICINES WHICH ARE USED IN DAILY PRACTICE.

1. *Vinegar of Meadow Saffron* is given in dropsy, in asthma arising from exposure to damp air, in coughs of long continuance, in gout, and in rheumatism; $\frac{1}{2}$ teaspoonful, two or three times a day, in water, or in a draught of 30 drops of vinegar, 10 grains of magnesia, 2 drachms of epsom salts, and a little sugar and water.

2. *Distilled Vinegar* is used to restore strength, and is applied to the nostrils in fainting hysterics, and headaches; in fevers it proves, also, refreshing.

3. *Strong Acetic Acid* is used in camphorated acetic acid, $\frac{1}{2}$ ounce of camphor to 6 ounces of acetic acid, and is a very powerful stimulant; steam of vinegar is inhaled in cases of putrid sore throat.

4. *Citric Acid* is a substitute for lemon-juice. 2 ounces, dissolved in 1 pint of water, are equal to 1 pint of lemon-juice; and 10 grains, in 2 drachms of water, is a dose. In feverish, inflammatory, and scorbutic diseases, it is used as a substitute for fresh lemon-juice. It is, when neutralized by a little pearl-ashes, so as to make an effervescing draught, one of the best remedies for allaying sickness and vomiting—especially sea-sickness.

5. *Hydrocyanic or Prussic Acid*, being the most deadly poison, is rarely administered. In spasmodic coughs, asthma, and hooping-cough, it is very useful.

6. *Hydrochloric or Muriatic Acid* is used, very diluted, in typhus fever, scarlatina, and ulcerated sore throat, or any disease having a putrid tendency.

7. *Nitric Acid*.—This mineral acid is principally used in other preparations, or in the destruction of tumors. It is sometimes used, very diluted, in chronic liver complaints and scrofula, 10 to 20 drops in a decoction of sarsaparilla.

8. *Sulphuric Acid*.—This most powerful mineral acid is applied in fixed rheumatic pains, old sprains, and itch. One ounce of sulphuric acid, diluted in 14 ounces of water, is used as a tonic or astringent medicine, in diabetes, spitting of blood, female irregularities, gargles, hectic sweats, to stop salivation, and to strengthen the digestive organs.

9. *Tartaric Acid* is a good substitute for citric acid, in forming cooling and refreshing drinks. 20 grains of tartaric acid mixed with 30 grains of bicarbonate of soda makes an artificial soda-water, which allays thirst, checks excessive perspiration, and acts gently on the bowels.

10. *Carbonate Ammonia*.—This is administered in convulsions, gouty acidities of the stomach, nervous affections, debility, and flatulency. It acts, in large doses, as an emetic. It is given, with opium, in diarrhœa of long standing, and it is considered the best medicine in muscular relaxation, and also when hoarseness proceeds from a relaxed state of the interior of the throat. As a smelling-salt it is used in fainting, for which it may also be used internally, in doses of 5 to 10 grains, as it quickens the action of the heart.

11. *Muriate Ammonia*, or Sal Ammonia.—This is employed in fomentations, in mania, plethoric apoplexy, violent headaches, and gargles. It is also used internally, in small doses, in the *Brown Mixture*, in affections of the mucous membrane.

12. *Starch* is given as an antidote in cases of poisoning by mercury, copper, &c.; also as a clyster, in combination with opium, in dysentery.

13. *Tartar Emetic*, or Tartrate of Potash and Antimony, is given in asthma, catarrh, croup, diseases of the lungs, hooping-cough, and the commencement of feverish diseases. If given to cause perspiration or expectoration, the dose is from $\frac{1}{4}$ to 1 grain; if as an emetic, from 1 to 2 grains. It is also employed externally as an ointment—1 to 2 drachms to 1 ounce of lard rubbed over the part; and in a few hours pustules appear on the skin.

14. *Nitrate Silver*, also called Lunar Caustic.—This powerful metallic salt is given in convulsions, $\frac{1}{15}$ of a grain increased to $\frac{1}{8}$, three times a day. It is applied, externally, to warts, and to dry, indolent ulcers, and excoriated nipples; also in ringworm and itch.

15. *Balsam Copaiva*.—This is a stimulant, a diuretic, and also a purgative, and is very efficacious in chronic catarrh, dysentery, gleet, gonorrhœa, and whites; the doses are from 20 drops to a teaspoonful, three times a day.

16. *Quick Lime* is given as an antidote, with milk, in poisoning with arsenic, and mineral and oxalic acids. In connection with linseed oil, it is applied to recent burns and scalds. In vomiting of food, it is the most effectual remedy; also in diarrhœa, it is very useful.

17. *Chloride of Lime*.—This is very valuable in destroying putrid odors and checking putrefaction, and in purifying chambers and buildings after contagious diseases:

18. *Camphor* is given in typhus fever, small-pox, measles, hysterics, epilepsy, and severe rheumatism. It exhilarates, and promotes perspiration. In cholera, the combination of camphor and opium is often of great service. Camphor water, or julep, is often employed as medicine.

19. *Spermaceti Ointment* is prepared by melting 1 pound

of lard, $\frac{1}{2}$ pound of spermaceti, and $\frac{1}{2}$ pound of white wax. This cerate is used as a dressing for blisters, and in place of cold cream.

20. *Turner's Cerate*.—This cerate is used for burns, scalds, and old ulcers.

21. *Basilicon Salve*, an excellent ointment, useful in ulcers, boils, and carbuncles.

22. *Aromatic Confection* is used as an antacid and carminative, in doses of from 10 to 30 grains; it is also used in diarrhœa and bowel complaints.

23. *Confection Senna* is a pleasant, mild, and effectual purgative, and, when combined with sulphur and cream of tartar, proves invaluable in piles and diseases of the rectum.

24. *Sulphate of Copper, or Blue Vitriol* is used to burn off proud flesh, and to stimulate obstinate ulcers. It is occasionally given as an emetic, from 2 to 10 grains.

25. *Blister Plaster*.

26. *Diachylon Plaster*.—This, on account of its adhesive-ness and non-irritating properties, is used to keep the edges of wounds together.

27. *Rosin Plaster*.—This is as much used as the above.

28. *Aloes*.—This is an active purgative; if combined with 2 grains of gamboge and ground ginger, it forms an active purge in a sluggish state of the bowels.

29. *Compound Extract Colocynth*.—This is a powerful, sure, and safe purgative. In connection with the extract of hyoscyamus, which neutralizes the strong drastic qualities of the first, it is used as pills, from which great benefit is derived, in obstinate constipation and sluggish state of the liver—5 grains of the extract, and 3 grains of hyoscyamus extract, made into 2 pills. It is used, also, in apoplexy, paralysis, insanity, and in some cases of obstructed female discharges.

30. *Extract Conium* is used as an anodyne, to relieve pain in tender glandular enlargements, cancer, and rheumatism.

It is useful in allaying troublesome coughs, but ought never to be given in fevers and inflammations. The dose is from 2 to 3 grains.

31. *Extract of Hyoscyamus.*—It is used for alleviating pain and irritation, to produce quiet and obviate spasm. Its use as a sedative in allaying irritation of the kidneys and bladder, is highly beneficial: in small doses in teething; the dose is from 3 to 10 grains, in form of pills, or in solutions, with emulsive mixtures.

32. *Extract of Opium.*—It is used as a sedative to soothe pains; in diarrhœa and cholera, combined with chalk, it effects a cure. Opium ought never to be administered in fevers, or in symptoms of determination of blood to the head. The dose of the extract of opium is from $\frac{1}{4}$ grain to 2 grains.

33. *Sulphate of Iron: Copperas.*—This is a tonic and astringent, principally used to correct female irregularities, and is combined with rhubarb or some bitter extract, but produces griping in the bowels in large doses.

34. *Gentian root.*—It is given as a tonic and stomachic in indigestion and hysteria, debility and intermittents. It is used in indigestion, &c., in the form of infusion. It is an excellent tonic; removes flatulence and creates appetite.

35. *Mercury with Chalk.*—This powder is an exceedingly mild, but valuable mercurial preparation. It is given to children to promote and improve the secretions of the liver, pancreas, and bowels. A few grains of rhubarb and soda, or some Dover Powders, may be given in combination. The dose is from 5 to 15 grains for adults.

36. *Calomel.*—This mercurial preparation, increasing the action of the secreting organs, promotes the action of the liver and intestinal mucus. It affects adults more than children. It is often combined with antimony, to promote the action of the skin, and as an alterative. As a purgative, from 2 to 5 grains are given in pills, followed by jalap, senna, &c.

It may be given in as large doses to children as to adults, without danger of producing salivation. In inflammation of the liver, pleura, and bowels, and in croup, it is given in small doses, with powdered opium—1 grain of opium to 2 grains of calomel.

37. *Corrosive Sublimate*.—It is a virulent poison, yet employed in chronic diseases of the skin and venereal affections, with sarsaparilla. The dose is from $\frac{1}{16}$ to $\frac{1}{8}$ of a grain.

38. *Iodide of Potassium*.—It is mostly used in scrofulous diseases, and for its resolvent influence in chronic visceral and glandular enlargements; in swelling of the glands of the neck, cancer of the breast, and syphilis. It is used both internally and externally. From 1 to 5 grains may be administered in a wineglassful of chamomile-tea three times a day. It is also of the greatest service in rheumatic affections and dropsy, and, jointly or separately, may be used with mercury. The dose of the iodide of potassium is from 2 to 6 grains.

39. *Soap Liniment*.—It is frequently used as a stimulating application in various local pains, sprains, bruises, in connection with laudanum.

40. *Liquid Ammonia, or Spirits of Hartshorn*.—It is applied to the skin to excite to action; to the nostrils and to the eyes as a stimulant; and is used in cases of torpor, paralysis, rheumatism, hysterics, &c.

41. *Liquor Potassa Arsenitis*.—Arsenite of potash is also called Fowler's Solution. This is a powerful tonic in ague, fever, periodic headache, St. Vitus' dance, epilepsy, and tic douloureux. It is given in doses of 3 to 5 drops three times a day, in water, after meals.

42. *Goulard's Extract—Solution of Sugar of Lead*.—It is used in external inflammation as a lotion, and is also applied in erysipelatous inflammation, whitlow, and inflamma-

tion of the eyes, for bruises, ulcers and abscesses. Goulard's Extract is never used internally.

43. *Epsom Salts—Sulphate of Magnesia.*—This purgative is administered in colic, stomach-ache, iliac passion, and dysentery. Its powers are increased by adding a little common salt. It is a mild and safe purgative, acting speedily on the bowels, to obviate flatulency; some warm carminative is added to it, like peppermint and ginger. To make a palatable drink of Epsom salts, add a few drops of oil of vitriol when dissolved, and then a little raspberry syrup. It is used as an antidote in cases of poisoning by lead and baryta. In indigestion, accompanied with constipation, small doses of Epsom salts, combined with infusion of gentian, columbo, chamomile, or quassia, afford great relief.

44. *Carbonate of Magnesia.*—It counteracts the acidity of the stomach, and is a purgative.

45. *Acetate of Morphine.*—Morphine is said to be less stimulating and less disposed to cause sweating, constipation of the bowels, and headache, than opium. It is preferred to the latter, which has a tendency to excite the brain. The dose of the acetate of morphine is from $\frac{1}{8}$ to $\frac{1}{4}$ grain.

46. *Linseed Oil*—Is only used externally, with lime-water, for burns, &c.

47. *Oil of Peppermint.*—This is a carminative. It has the property of expelling wind, and is useful in administering other medicines.

48. *Olive Oil.*—It is administered when metallic poisons or acid substances have been swallowed. As an emetic, 4 to 5 ounces are effectual. It is used in clysters, and as a liniment.

49. *Castor Oil.*—It is used to evacuate the contents of the bowels without any griping or irritation. Its nauseous taste is covered by gin, peppermint-water, warm milk, or yolk of an egg. It has the advantage over all other aperients for its quick operation, and only gripes when the oil is rancid.

50. *Oil or Spirits of Turpentine*.—This is a stimulant, diuretic, cathartic, and an excellent anthelmintic or worm-destroyer. It has been found useful in epilepsy, hysterics, and in convulsions of infants. It is also used in sciatica, lumbago, disease of the nerves, and as an aperient in gout. Combined with castor oil, and given to persons troubled with worms, it is certain to expel them. As an enema in obstinate costiveness and colic, it has been much used; externally, as an embrocation for rheumatism and paralysis of the extremities. It is good for burns and scalds and indolent humors. The dose as a diuretic is from 10 to 50 drops; as a purgative, from 1 to 2 tablespoonfuls, taken with a little essence of ginger, or with yolk of an egg.

51. *Croton Oil* is used as a powerful purgative.

52. *Blue Pill—Mercurial Pill*.—This pill is usually employed in obstructions of the liver, jaundice, and many other complaints. It is an excellent stimulant to the action of the bile, especially if followed by a brisk dose of salts and senna on the succeeding morning.

53. *Plummer's Pill*.—This pill is used as an alterative, in conjunction with sarsaparilla and iodide of potassium, in chronic skin diseases and chronic liver affections. Dose from 5 to 10 grains.

54. *Sugar of Lead*.—It is considered the most efficient medicine in stopping bleeding from the lungs and womb. It ought only to be taken as pills, in connection with opium.

55. *Powdered Gum-arabic* is given to allay troublesome coughs, and to diminish irritation; and in inflammation of the chest, bladder, and kidneys, as an emollient and demulcent.

56. *Alum*.—This is administered in diabetes, diarrhœa, bleeding from the nose, lungs, and womb, and in intermittent fevers, and as a lotion for the eyes. Also a gargle, with decoction of oak-bark; and as an injection for fluor albus.

57. *Antimonial Powder (James' Powder)*.—It is given in feverish cases, as it creates perspiration. In feverish and scrofulous diseases, acute rheumatism, and gout, it is beneficial. Dose, from 3 to 5 grains.

58. *Cinnamon Powder* is an aromatic stimulant, tonic, and astringent, administered in weakness of the stomach and alimentary canal, fluxes and indigestion.

59. *Compound Chalk Powder* is usually given in early cases of diarrhœa, in doses from 10 to 20 grains, as an astringent and antacid.

60. *Prepared Chalk* is given when acidity exists in the intestines, and after irritating matters have been removed from the bowels in diarrhœa. When thin watery matter is discharging from ulcers, it is a good external application.

61. *Ipecacuanha Powder*.—This is administered as an emetic, to cause expectoration, perspiration, and to counteract spasmodic affections. When used as an emetic, the dose is from 10 to 20 grains; but it should not be given to persons subject to bleeding, flowing of blood to the head, afflicted with rupture, or women about to become mothers. When given to promote expectoration, the dose is from 1 to 2 grains. As a sudorific, or promoter of perspiration, in colds, influenza, and rheumatic affections, it is given in doses of from 1 to 4 grains.

62. *Dovers Powder*, or Compound Powder of Ipecac.—This is one of the most certain, powerful, and valuable diaphoretic preparations we have, when it is deemed necessary to produce perspiration and assuage pain. In slight colds, coughs, and rheumatic affections, it is of great service, and also in diarrhœa and dysentery. Its action on the skin is greatly promoted by the copious use of warm diluents, such as gruel, barley, or linseed. The dose of Dovers Powder is from 5 to 10 grains.

63. *Jalap Powder*.—This is a safe and good medicine, a

stimulating purgative, and acts most powerfully on the colon. It increases the excretions, so as to remove water from any of the cavities of the body; for this purpose it is combined with calomel, and for dropsy it is combined with cream of tartar. The usual powder is: jalap, 15 grains; ipecac, 5 grains; and oil of cinnamon, 2 drops—taken at bedtime.

64. *Compound Kino Powder* is an astringent, containing a small quantity of opium in its composition. It is given in diarrhœa and dysentery of long standing.

65. *Powdered Opium*.—In particular cases, opium supports the powers of life, and allays spasms, pain, and irritation. It must be avoided where inflammatory action exists, in consumption, attended by a dry cough and increased pulse. A quarter of a grain, taken frequently, keeps up an exhilarating effect, and 1 to 2 grains act as a narcotic or sleeping-dose.

66. *Saltpetre, Nitre*, or Nitrate of Potassa.—This, with rose-water, is a cleansing gargle. It acts as a diuretic, promoter of perspiration, and as a refrigerant or cooling medicine, when the skin and body are very hot; in all febrile disorders, it reduces the frequency and force of the pulse; is given in continued fever, with tartar emetic or calomel, with good effect. Nitre and gum arabic are used for diminishing the scalding in passing urine in certain diseases; also in scurvy. The dose is from 10 to 30 grains.

67. *Soluble Tartar*, or Tartrate of Potassa.—This is a mild and good purgative.

68. *Powdered Rhubarb* is administered as a tonic in indigestion and a weakened state of the bowels. It is generally given in diarrhœa, any irritating matter in the bowels being removed by its purgative effect, before it acts as an astringent. It may be given to children when quite young, combined with calomel, in doses of from 1 to 2 grains. As a purgative, the dose is from 20 to 30 grains; as a stomachic or tonic, from 3 to 6 grains.

69. *Scammony Powder*.—It is a powerful cleansing medicine, usually given to destroy worms and correct a slimy state of the bowels, to which children are liable. It is generally mixed with calomel and a little cinnamon.

70. *Powdered Squills* is a stimulant, diuretic, and expectorant. It is employed as an expectorant in coughs of long standing, bronchitis; as a diuretic it is given in dropsy, combined with small doses of calomel or blue-pill. The syrup of squills is given to children laboring under whooping-cough, in doses of 1 to 2 teaspoonfuls three or four times a day.

71. *Ergot of Rye* is employed to assist labor and stop excessive discharges. From 10 to 15 grains is given every half hour.

72. *Quinine* (disulphate of quinine).—It is an arcanum, or sovereign remedy, by its great tonic and fever properties, and the only instances where quinine cannot be used, is in great nervous or vascular irritation, active inflammation, and fulness of blood. Intermittent fevers are diseased affections of the nervous system, and herein quinine manifests its greatest power. It is, however, a remarkable fact, that this disease may be cured by sudden and powerful impressions, both mentally and bodily; thus, sudden fright, terror, intoxication, a large dose of opium or the administration of quinine, all happening or given during the intermission, will often prevent the return of the paroxysm. In order to insure that quinine may set well on the stomach, an emetic is given previously to employing quinine, such as 15 grains of ipecac and $\frac{1}{2}$ grain of tartar emetic, or a calomel pill at night and senna draught in the morning. Quinine is also given in tic douloureux, St. Vitus' dance, bleedings in discharges attended with great debility, such as whites, old diarrhoea, and dysentery, in enlargement of the glands of a scrofulous nature, in erysipelas, and in shattered and broken-down constitutions. It is administered in doses from 1 to 20 grains.

73. *Castile Soap*.—It is given in jaundice and stone, combined with rhubarb or gentian.

74. *Senna Leaves*.—The infusion of senna is employed in medicine. It is well adapted as an active and stimulating purgative in constipation and inactivity of the bowels, in worms, and many other cases; it acts well, and is a safe purgative for children, females, and elderly persons. If combined in infusion with a teaspoonful of Epsom salts or tartrate of potash, it is called the Black Draught.

75. *Borax* or *Borate of Soda* is employed, mixed with honey, for ulcers in the mouth, thrush in children, and as a lotion in skin diseases known as *liver spots*.

76. *Carbonate of Soda* is given as an antacid, from 10 to 30 grains, in indigestion. It is more frequently used as an effervescing draught, with citric or tartaric acid, and makes a cooling drink in fevers. It is the principal ingredient in Seidlitz powders: 40 grains of soda and two teaspoonfuls of Rochelle salt are mixed together, and 30 grains of tartaric acid separately dissolved, is drunk while effervescing. The soda powders are prepared from 30 grains of soda and 25 grains of tartaric acid; and the ginger-beer powders are the same, with the addition of a few grains of powdered ginger.

77. *Rochelle Salt*, (tartrate of potassa and soda).—It is a mild, laxative, and cooling salt, usually given in the form of Seidlitz powders, as last stated.

78. *Compound Spirit of Sulphuric Ether* (Hoffman's Anodyne).—This very volatile fluid is a stimulant, narcotic, and antispasmodic. It rouses the nervous system and increases the natural heat. Is given in languor, torpor, nervous affections, and spasms, in fainting fits, lowness of spirits, cramps of the stomach, colic, dry asthma, and typhus. The dose is from 30 to 40 drops.

79. *Sweet Spirits of Nitre*.—Is used as a diuretic, anti-spasmodic, diaphoretic, and refrigerant in inflammatory affec-

tions; a useful diuretic in dropsy, particularly that following scarlatina. It is useful in relieving flatulency and sickness; as a diaphoretic or sweating draught in febrile complaints, it is given with 20 or 30 drops of antimonial wine and a teaspoonful of acetate of ammonia. The usual dose is half a teaspoonful.

80. *Aromatic Spirits of Ammonia*.—This is an excellent stimulant, and frequently employed in hysteria, flatulent colic, and nervous debility. The dose is half a teaspoonful with spirits of lavender.

81. *Rectified Spirits of Wine* is used as a tincture. It is very useful to wash the back and sore parts of bed-ridden persons; also to the nipples when inclined to be sore, to the feet when the skin is blistered from walking, on the chest to excite the action of the heart in fainting or suspended animation.

82. *Sublimed Sulphur* (flowers of sulphur).—Is a laxative and promoter of perspiration; is given in skin diseases; is a certain cure for the itch.

83. *Tincture of Foxglove* is given in inflammatory diseases, particularly when accompanied with increased pulse. Is of great service in dropsical diseases, on account of its diuretic properties; in bleeding from the nose and lungs is serviceable for its sedative properties. The dose is from 10 to 15 drops three times a day.

84. *Tincture of Iron*.—This acts most powerfully upon the urinary organs. In cases of retention, 10 drops in water every ten minutes, affords relief; it stays bleeding from the bladder, kidneys, and womb: as it produces costiveness, castor oil is administered soon after the tincture has been taken.

85. *Tincture of Henbane* (*hyoscyamus*).—Is an excellent narcotic, not affecting the head nor disturbing the biliary secretions like opium; it has a soothing effect on persons

suffering from great nervous irritability; it relieves pain, promotes sleep, and alleviates spasms.

86. *Tincture of Opium* (laudanum).—It allays pain when rubbed on the skin. It is one of the most valuable remedies we possess, but requiring care in its use. It mitigates pain, allays spasms, promotes sleep, relieves nervous restlessness, produces perspiration. The dose is from 10 to 20 drops.

87. *Compound Tincture of Rhubarb*.—This medicine is a popular remedy in various disordered states of the stomach and bowels, especially at the commencement of diarrhœa and in flatulent colic; in indigestion accompanied with debility, in combination with gentian, it is beneficial, by promoting the appetite and assisting the digestive process.

88. *Compound Tincture of Senna*.—It is useful in costiveness attended with flatulence, and is a warm and good purgative.

89. *Blue Ointment* is frequently rubbed into the body for bringing it under the influence of mercury in many severe diseases.

90. *Citron Ointment*.—This ointment is applied to the edge of the eyelids in an ulcerated state, and it is well applied in many chronic inveterate skin diseases.

91. *Sulphur Ointment* is a cure for the itch.

92. *Colchicum Wine* (from the bulb of meadow saffron.) This is useful in gout; it greatly affects the arterial system.

93. *Sulphate of Zinc*.—As an emetic it is used especially when poisons have been taken—it is very prompt in action; It is a good tonic and astringent; it is also administered in diarrhœa and chronic dysentery. It is given in gleet and whites; as a lotion in skin diseases, as a wash for weak and inflamed eyes.

94. *Paregoric Elixir*.—This is an old and valuable medicine; is principally used as a cough medicine: it diminishes the sensibility of the bronchial tube and checks expectoration.

95. *Cod-liver Oil* is used in all wasting diseases, great emaciation, and slow decay, as occurs in consumption, in scrofula, enlargement of the glands, and rickets—it is unexceptionable; in rheumatism, where the muscles and tendons are rigid and the joints stiff; in gout and long-standing skin diseases, it is very beneficial.

96. *Compound Tincture of Lavender* (red lavender), is much employed as a stimulant and stomachic, to relieve uneasiness of the stomach, wind, low spirits, languor, and faintness.

97. *Sarsaparilla*.—This root has long enjoyed the reputation of being a powerful medicine in syphilis and scrofula.

98. *Valerian*.—This medicine is a tonic and antispasmodic, and used in hysteria, epilepsy; and also, given with bark, in intermittent fevers.

99. *Assafetida*.—This is an excellent stimulant, expectorant, antispasmodic; given in hysterical complaints, asthma, and worms, in pills of 4 to 5 grains.

100. *Caraway Seed*.—They are very grateful on the stomach of those suffering from indigestion.

101. *Collodion*.—This solution from gun-cotton in sulphuric ether is very usefully applied with a small brush over cuts or scratches; it may also be beneficially used over the face in small-pox, just before the pock gets to its height, and will thereby prevent the scars remaining, to the disfigurement of the sufferer.

102. *Tincture of Arnica Flowers*.—The most useful preparation in sprains and bruises.

CHAPTER II.

MATERIA MEDICA, OR THE USE OF FAMILY MEDICINES.

MEDICINES.	DISEASES PROPER FOR.	ADULTS.
<i>Aether</i>	Asthma, cramp, and flatulency	30 drops to 1 drach.
<i>Aethiop's mineral</i>	Scald head, cutaneous eruptions	15 to 30 grains.
<i>Almonds, emulsion of</i>	Cough	wineglassful.
" oil of		1 to 3 drachms.
<i>Aloes, socotrine</i>	Obstinate costiveness	10 to 20 grains.
" tincture of	" and worms	3 to 6 drachms.
" watery extract of	Costiveness	10 to 15 grains.
<i>Alum powder</i>	Flooding, chronic dysentery	3 to 10 grains.
<i>Ammoniac gum</i>	Chronic cough, asthma, &c.	10 to 15 grains.
" milk of		3 tablespoonfuls.
<i>Antimonial powder</i>	Inflammatory fever, pleurisy, &c.	3 to 5 grains.
" wine, as emetic		2 to 8 drachms.
<i>Ditto, as an alterative</i>	St. Anthony's fire, cutaneous eruptions	12 to 20 drops.
<i>Aromatic confection</i>	Purging, cramp in stomach	15 to 30 grains.
<i>Assafoetida</i>	Hysterics, asthma, whooping-cough	
" tincture of		30 to 60 drops.
" volatile spirit of	" and fainting	20 to 40 drops.
" pill		10 to 15 grains.
<i>Balsam of copaiva</i>	Whites, gleet, gravel	20 to 40 drops.
" of Peru	Flatulence, asthma, gleet.	5 to 10 drops.
" Tolu, tincture of	" and chronic cough	30 to 60 drops.
<i>Bark, Peruvian, powder</i>	Ague, indigestion, weakness	20 to 60 grains.
" decoction of	Relaxation and weakness	3 to 4 tablespoonfuls
" tincture of		2 to 4 drachms.
<i>Buchu leaves</i>	Irritation in bladder, prostate gland, &c.	wineglassful.
" infusion of		
" tincture of		2 to 3 teaspoonfuls.
<i>Calomel</i>	Veneral disease, foul ulcers, &c.	1 to 2 grains.
<i>Camphor</i>	Whooping-cough, convulsive fits	2 to 4 grains.
" julep	Nervous fever	2 to 4 tablespoonfuls
<i>Cardamom seeds, tincture of</i>	Indigestion, flatulence	2 to 3 drachms.
" comp. ditto		2 to 4 drachms.
<i>Castor oil, cold drawn</i>	Colic, costiveness	4 to 8 drachms.
<i>Cascarilla</i>	Indigestion, weakness	
" tincture of		1 to 3 drachms.
<i>Catechu, tincture of</i>	Chronic looseness, flooding	1 to 2 teaspoonfuls.
<i>Chalk, prepared</i>	Looseness, acidity	10 to 15 grains.
<i>Chamomile flowers</i>		
" powder of	Indigestion, worms, &c.	10 to 20 grains.
<i>Cinnamon powder</i>	" flatulence, &c.	5 to 10 grains.
" essence of	Flatulence, colicky pains	3 to 10 drops.
" tincture of	Looseness	3 to 4 drachms.
<i>Columbo powder</i>	Indigestion, chronic looseness	10 to 20 grains.
" tincture of		1 to 3 drachms.
<i>Crabs' claws, prepared</i>	Purging, heartburn	15 to 20 grains.
<i>Oretaceous pow. with opium</i>	Obstinate purging and dysentery	10 to 20 grains.
<i>Contrainerva powder</i>	Recent colds, rheumatism	10 to 40 grains.
<i>Cod-liver oil</i>	In debility, strumous children, cough, consumption, &c.	1 tablespoonful.
" tincture	Rheumatism, gout	1 grain.
<i>Colchicum seeds</i>		½ teaspoonful.
" tincture	Costiveness	10 to 20 grains.
<i>Colocynth pill, compound</i>		10 to 15 grains.
" extract, comp.		10 to 15 grains.
" powder		10 to 15 grains.
<i>Cream of tartar</i>	Inflammatory eruptions of the skin, &c.	1 to 4 drachms.
<i>Cubebs, ground</i>	Fluor albus, gleet, &c.	15 to 30 grains.
<i>Dovers powder</i>	Rheumatism, recent colds, &c.	10 to 20 grains.
<i>Elixir of vitriol</i>	Indigestion, flatulence	10 to 20 drops.
<i>Electuary, lenitive</i>	Costiveness	2 to 3 drachms.
<i>Epsom salts</i>		4 to 8 drachms.
<i>Foxglove, powder of</i>	Dropsy	½ to 2 grains.
" tincture of	Consumption, palpitation	10 to 40 drops.

MEDICINES.	DISEASES PROPER FOR.	ADULTS.
Gentian, tincture of	Indigestion, flatulence, &c.	1 to 2 drachms.
" extract of	" "	8 to 10 grains.
Ginger powder	Gout, indigestion, flatulence.	20 to 60 grains.
" tincture of	Flatulence "	1 to 2 drachms.
Guaiaecum gum	Chronic rheumatism, gout	8 to 15 grains.
" vol. tincture of.	" "	1 to 3 drachms
Hartshorn, spirit of.	Hysteria, convulsions, heartburn	20 to 40 drops.
Hemlock, powdered	Hooping-cough, cancer	2 to 3 grains.
" extract of	" "	2 to 3 grains.
Hiera piera	Costiveness, flatulency	15 to 20 grains.
Hoffman's anodyne, or compound spirit of.	Nervous fever, asthma, hysterics	30 to 40 drops.
Jalap, powder	Costiveness	20 to 30 grains.
" extract of	" "	10 to 15 grains.
" tincture of	" "	2 to 4 drachms.
Iodine, tincture of	Scrofula and wen	10 to 30 drops.
Ipecacuanha powder	" "	20 to 30 grains.
" wine	" "	4 to 8 drachms.
Kino gum, tincture of.	Looseness	2 to 3 drachms.
Lavender, compound spirit	Faintness, or lowness of spirits	50 to 80 drops.
Lobelia inflata, extract	Asthma and winter cough	1 grain.
" tincture	" "	20 to 40 drops.
" ethereal	" "	40 to 80 drops.
Magnesia	Heartburn and acidity	20 to 40 grains.
" calcined.	" "	20 to 40 grains.
Manna	Costiveness	4 to 8 drachms.
Mercurial pill.	Veneral disease and liver complaint.	5 to 12 grains.
Mercury, with chalk	Scald head, cutaneous eruptions, &c.	5 to 10 grains.
Musk	Convulsions, locked jaw, &c.	8 to 20 grains.
Muriatic acid, dilute	Scrofula, cutaneous eruptions	10 to 30 drops.
Myrrh, powder	Green sickness, weakness.	5 to 10 grains.
" tincture of	" "	1 to 2 drachms.
Nitre, powder, purified	Strangury, heat of urine, fever	5 to 20 grains.
" sweet spirit of.	" "	20 to 60 drops.
Nitric acid, dilute	Diabetes, scrofula.	12 to 30 drops.
Nutmeg, spirit of	Flatulence, cramp in stomach	4 to 6 drachms.
Opiate confection	Purging, colic, &c.	10 to 20 grains.
Opium, purified.	Restlessness, acute pains, asthma	1 to 2 grains.
" tincture of	" "	10 to 30 drops.
Oyster-shells prep.	Looseness, acid in stomach, &c.	10 to 20 grains.
Paregoric, elixir	Cough, asthma, cramp	1 to 2 drachms.
Peppermint, essence of.	Colicky pains, flatulency, &c.	3 to 12 drops.
Poppies (white), extract of	Spasms, acute pain, cough.	5 to 10 grains.
" syrup of	" "	2 to 4 drachms.
Quassia, tincture of.	Indigestion, flatulency	30 to 60 drops.
Rhatany powder	Ague, diabetes	10 to 40 grains.
" tincture of.	Indigestion, relaxation, whites	2 to 4 drachms.
Rhubarb powder	Costiveness	20 to 30 grains.
" tincture of	" colic, &c.	4 to 8 drachms.
Rochelle salt.	" "	6 to 12 drachms.
Roses, infusion of.	Indigestion, flooding, &c.	1 to 2 ounces.
" conserve of.	Cough	1 to 2 drachms.
Saffron, syrup of	Lowness of spirits	2 to 3 drachms.
Salt, Glauber's	Costiveness, &c.	6 to 12 drachms.
" Epsom, purified	" "	4 to 8 drachms.
" Cheltenham	" "	6 to 12 drachms.
" Polychrist.	Feverish heat	1 to 3 drachms.
" tasteless.	Costiveness, &c.	6 to 12 drachms.
" of tartar.	Heartburn, rickets.	5 to 8 grains.
Sarsaparilla powder.	Scrofula, &c.	20 to 60 grains.
" comp. decoc. of	" "	3 to 4 ounces.
Scammony powder	Obstinate costiveness	10 to 20 grains.
" compound	" "	15 to 30 grains.
" comp. with calomel	" worms, and dropsy.	15 to 25 grains.
Senna, infusion of.	Costiveness and worms.	2 to 3 ounces.
" tincture of.	" colic	6 to 12 drachms.
Soda, carbonated.	Heartburn	20 to 40 grains.
Soluble tartar	Piles and costiveness	4 to 6 drachms.
Spermaceeti powder.	Recent cough	1 to 2 drachms.
Spirit, nitre, sweet.	Strangury, gravel, fevers	20 to 60 drops.
" sal volatile	Hysterie and fainting fits	20 to 60 drops.
" foetid	" "	20 to 60 drops.
Syrup of white poppies.	Coughs, restless, irritation, fever	2 to 4 drachms.
" buckthorn	Costiveness	2 to 4 drachms.
" ginger.	Flatulence, cramp in stomach	2 to 3 drachms.

MEDICINES.	DISEASES PROPER FOR.	ADULTS.
Squill powder	Dropsy, asthma, chronic cough	1 to 2 grains.
" oxymel		2 to 4 drachms.
Squill tincture	Dropsy, asthma, chronic cough	15 to 30 drops.
Steel, wine of	Indigestion, rickets, worms, &c.	3 to 6 drachms.
" muriat. tincture	" " "	10 to 30 drops.
" salt of	" " "	1 to 3 grains.
" prepared	" " "	10 to 40 grains.
Sugar or acetate of lead	Bleedings, internally and in lotions exter.	1 to 5 grains.
Sulphate of quinine	Ague, general debility	2 to 8 grains.
Sulphur, flowers of	Cutaneous eruptions, piles, worms	1 to 2 drachms.
" milk of	" " "	1 to 2 drachms.
Tartar emetic		1 to 2 grains.
Tin powder	Worms	20 to 40 grains.
Tincture aloes	Costiveness, worms, green sickness	3 to 6 drachms.
" assafoetida	Hysterics, asthma, hooping-cough	30 to 60 drops.
" bark, Peruvian	Indigestion, weakness, &c.	2 to 4 drachms.
" Huxham's ditto	" " "	2 to 4 drachms.
" bensoin, comp.	Flatulence, asthma	20 to 40 drops.
" cantharides	Hooping-cough	10 to 30 drops.
" cardamoms	Indigestion, flatulence	2 to 3 drachms.
" " comp.	" " "	2 to 4 drachms.
" cascarilla	" " "	1 to 3 drachms.
" catechu	Purgings, relaxation	1 to 2 drachms.
" columbo	Indigestion, weakness	1 to 3 drachms.
" gentian, comp.	" flatulence	1 to 2 drachms.
" gualiacum, gum	" gleet, whites, &c.	20 to 60 drops.
" " volatile	" rheumatism, &c.	1 to 3 drachms.
" henbane	Spasms, acute pains, &c.	20 to 60 drops.
" hops	Nervous indigestion	1 to 2 drachms.
" jalap	Obstinate costiveness	2 to 4 drachms.
" myrrh	Green sickness, debility, &c.	1 to 2 drachms.
" opium	Spasms, acute pains, &c.	18 to 30 drops.
Turpentine, Venice	Gleet, fluor albus, gravel	10 to 15 grains.
" spirit of	" gravel, rheumatism	15 to 20 drops.
Valerian powder	Nervous headache, &c.	20 to 30 grains.
" tincture of	" " "	1 to 3 drachms.
" volatile	Lowness of spirits, &c.	40 to 80 drops.
Vitriol, elixir	Indigestion, flatulence, relaxation	10 to 20 drops.
Wine of colchicum	Rheumatism and gout	20 to 30 drops.
" ipecacuanha		4 to 8 drachms.

CHAPTER III.

MEDICAL CASES; THEIR SYMPTOMS AND TREATMENT.

250. *Absorbents, or Antacids*, are medicines administered to counteract acidity in the stomach or intestinal canal. In most cases, emetics and aperients are given. The principal remedies are :

Carbonate of Ammonia,	in doses from	5 grains to 1 scruple,
Liquor of	“ “ “	10 to 20 drops,
Aromatic Spirit of Ammonia	“ “ “	20 to 30 “
Lime Water	“ “	2 ounces to $\frac{1}{2}$ a pint,
Calcined Magnesia	“ “	20 to 40 grains,
Carbonate of Magnesia	“ “	$\frac{1}{2}$ to 2 drachms,
“ Potash	“ “	10 grains to $\frac{1}{2}$ drachm,
Solution of	“ “ “	10 drops to $\frac{1}{2}$ “
Carbonate of Soda	“ “	10 grains to $\frac{1}{2}$ “
Soda Water	“ “	$\frac{1}{2}$ a pint.

251. *Ague*.—The intermittent fever occurs every 24 hours, every 48 hours, or every 72 hours; it has three stages—1. The cold, which is accompanied by convulsive shaking; 2. The hot, with pains in the head; and 3. The sweating, when perspiration takes place. During the first stage, bathe the feet in warm water; if possible, procure a warm bath; give warm drinks and cordials to promote perspiration, ether or opiates, and, if severe, an emetic. In the second stage, keep giving as in the first, with cold, acidulated liquids; if there be congestion of blood to the head, or delirium, leeches or cupping must be applied to the temples, and no opiates administered. During the time between the stages, give bark, and wine, and aromatics; if these occasion purging, give opiates and astringents; if costiveness, rhubarb; if the bark produces sickness, then change it for quinine, in full doses.

252. *Alteratives* are medicines that effect a gradual cure, and do not affect the bowels in any unusual manner. They are antimonials, mercurials, hemlock, guaiacum, sarsaparilla, &c. The usual way in which a mercurial alterative is given, for cutaneous diseases, indigestion, &c., is in the form called Plummer's pill, thus:

Calomel and antimony, of each, 1 drachm,
Guaiacum, powdered, 2 drachms.

Mix, and make into pills of 5 grains each, to be taken night and morning.

253. *Anodynes* are narcotic, sedative, and soporific. Sometimes a particular narcotic will have no effect, but on changing to another, the desired effect is produced. Examples and combinations in which they may be used:

A Pill.

Purified opium, 4 grains,
Extract of henbane, 15 "
" lettuce, 10 "

Mix, and make into 6 pills; take one at bedtime in long-continued cough.

254. *Draught.*

Camphor water, 1 ounce,
Compound spirit of ether, $\frac{1}{2}$ drachm,
Tincture of opium, 10 drops,
Syrup of poppies, 1 drachm.

Mix, and take at bedtime in influenza, cough, cold, bronchitis, &c.

255. *For Heartburn.*

Carbonate of magnesia, 10 grains,
Carbonate of soda, 5 grains,
Ginger, powdered, 5 grains,
Sugar or liquorice, powdered, 15 grains.

Take as a powder, two or three times a day.

256. *For Gravel, Heartburn, and Diarrhœa.*

Liquor of potass, 2 drachms,
Lime water, 6 ounces.

A teaspoonful or two occasionally in beef tea.

257. *Anthelmintics.*—These are medicines for worms, given on an empty stomach, with treacle. Those that do not purge ought to have some aperient given after them :

For Tape Worms.

Gamboge, 5 grains,
Calomel, 5 grains,
Treacle, a sufficient quantity.

Make a bolus to take on awaking in the morning.

258. *Antiseptics* prevent putrefaction. They are the tonics ; as Peruvian bark, chamomile, &c.

Electuary in Scurvy.

Bark, powdered, $\frac{1}{2}$ ounce,
Aromatic confection, $\frac{1}{2}$ ounce,
Syrup of oranges, a sufficient quantity.

Mix, and take the size of a nutmeg every quarter of an hour in a glass of seidlitz or soda water.

259. *Scurvy in the Gums.*

Infusion of roses, 6 drachms,
Alum, $\frac{1}{2}$ drachm,
Honey, 1 drachm.

Mix, and make into a gargle.

260. *Antispasmodics.*—Spasms are involuntary contractions of the muscles ; when from irritation, narcotics are best, as opium, camphor, and ether ; when from debility, tonics, as zinc, mercury, and Peruvian bark ; but those truly antispasmodics are musk, castor oil, combustible animal oil, ammonia, assafœtida, valerian, &c.

Anti-Hysterical Mixture.

Take 1 drachm of assafœtida, and gradually mix well with
 Peppermint water, $\frac{1}{2}$ pint,
 Aromatic spirit of ammonia, 2 drachms,
 Tincture of castor, 3 drachms,
 Sulphuric ether, 1 drachm.

Strain, and take a tablespoonful every two hours.

261. *Draught in Palpitation of the Heart, with great Nervous Irritability.*

Tincture of foxglove, 10 drops,
 Camphor mixture, 1 ounce,
 Tincture of columbo, 1 drachm.

To be taken twice a day.

262. *Aromatics.*—These have a fragrant smell and an agreeable taste. They are administered to dispel wind from the bowels, and are, on this account, called carminatives :

For Flatulent Colic.

Spirit of sulphuric ether, 2 drachms,
 Compound tincture of cardamoms, $\frac{1}{2}$ ounce,
 Spirit of aniseed, 6 drachms,
 Oil of caraway, 12 drops,
 Syrup of ginger, 2 drachms,
 Peppermint water, 5 ounces.

Mix, and take two tablespoonfuls when the wind is troublesome.

263. *Astringents* diminish excessive discharges, and often lessen morbid sensibility or irritation, and may thus restore strength.

Ointment.

Powdered galls, 1 drachm.
 Prepared hogs' lard, 1 ounce.

Apply to the part, in piles, &c.

264. *Draught for Uterine and other Bleedings :*

Muriated tincture of iron, 10 drops.

Water, 1 ounce.

Take every three hours.

265. *Pills for Internal Bleedings, &c. :*

Superacetate of lead, 3 grains.

Purified opium, 1 “

Extract of hemlock, 10 “

Make three pills; one to be taken twice a day. Drink after them vinegar and water.

266. *Boils* are symptoms of a weak constitution and disordered digestion. Administer simple aperient medicine. Give doses of 20 drops of liquid potass in milk three times a day; or from 10 to 20 grains of carbonate of soda in infusion of orange peel. Sea bathing is useful.

267. *Inflammation of the Bowels.*—Pain is felt around the navel, sickness at the stomach, wind, bilious vomiting, thirst, heat, and anxiety. Great costiveness, and difficulty in passing the water, are its symptoms. Bleed freely immediately, and if the pain has not ceased, do so again within four hours. Apply twenty leeches to the stomach, put a blister on the bowels or upper part of the thigh. When sickness has abated, give 10 to 15 grains calomel, made into small pills; let this be followed by a mild aperient draught of senna or castor oil. A little barley water or beef tea may be the patient's drink.

268. *Burns and Scalds.*—These frequent and painful accidents require prompt attention. Place the patient in bed, and keep him warm. Should he be troubled as if with cold, give some wine or brandy and hot water, with a full dose of opium. Should the skin be broken, wet applications are best; but if not broken, the blisters being whole, then dry ones are preferable. This should always be remembered—that the more the injury is kept from the air the better.

269. *Carbonic Acid Gas*.—Accidents arise from entering brewers' vats, wells, and other places where the gas has accumulated, and there is no circulation of air; from close rooms, in which coals are burnt, and where there is no chimney for the smoke to pass off; also from burning charcoal. The person drops down insensible, and must be brought out into the open air. A person, if quick, by placing a handkerchief over the mouth, or a sponge dipped in lime water, may rescue the insensible body. The treatment must be with artificial respiration, warm baths, stimulants, &c.

270. *Carminatives*.—They ease pain and dispel wind.

Draught for Flatulency and Indigestion.

Orange peel,	3 drachms.
Lemon “	2 “
Ginger powder,	$\frac{1}{2}$ “
Boiling water,	8 ounces.

Infuse two hours, and strain; then add to the above—

Spirit of peppermint, $\frac{1}{2}$ ounce.

“ lavender, $\frac{1}{2}$ drachm.

To be taken three times a day.

271. *For Wind in the Intestines*, particularly the colon, which violently distends them:

Assafœtida,	6 grains.
Rhubarb,	4 “
Oil of anise,	5 drops.

Make two pills, and take every five or six hours.

272. *Chapped Hands*.—Boiled potatoes not only cleanse the hands, but prevent chapping in winter, and keep the skin soft and healthy.

273. *Chicken Pox*.—This disease is contagious, attended with pustular eruptions, mostly confined to the period of childhood, and appears but once in a life-time. A chilliness comes over the body, then flushes of heat, pains in the back and head, thirst, restlessness, a quick pulse, and an

eruption. From the second to the fourth day the vesicles, or little spots, are filled with a yellowish watery fluid; about the fifth day they die away, leaving crusts or scales, which fall off on the seventh or eighth day. A little cooling aperient medicine should be taken, and a low diet adhered to. Should the fever be high, take small doses of antimonial powder, with saline draughts, and nitre with plenty of water, and use gentle laxatives or softening clysters. Tepid baths may be used when the patient is recovering.

274. *Cholera*.—This disease usually begins with violent griping pains, vomiting, and is followed by purging and spasms of the muscles of the stomach, sometimes extending to the legs and arms; the tongue is dry, urine high-colored, thirst urgent, pulse weak and frequent, and strength rapidly fails. The treatment consists in first allaying the spasm and irritable state of the digestive canal, by giving 5 grains of calomel with one grain of opium, followed by repeated injections of gruel or starch in large quantities, to bring away the irritating matter—repeating the dose of calomel every two or three hours, if needful. Warm fomentations, or turpentine mixed with ammonia or soap liniment, may be freely applied over the whole of the bowels. Should the surface of the body become cold, and symptoms of exhaustion appear, it will be necessary to give stimulants, as small quantities of brandy and hot water, camphor, sal volatile, &c. When the more urgent symptoms have been relieved, the bowels may be emptied by gentle laxatives or injections, and a little nourishing diet of a farinaceous kind may be permitted during convalescence.

275. *Colds*.—In slight cases, great abstemiousness should be observed—some people term it “starving a cold.” Drink abundantly of gruel or barley water, with a little lemon juice or cream tartar in it. In more severe cases, where there is pain in the breast and difficulty in breathing, then bleed.

Use only a low, cooling diet, and if not relieved, blister over the part affected. Take small but frequent doses of antimonials and other medicines, to promote perspiration, called diaphoretics, with plenty of gruel or barley water; also gentle aperients. When the cough is annoying, and there is soreness of throat on the cessation of inflammation, use demulcents. If sleep be distressingly disturbed, take an opiate, with a little purging medicine, at bedtime. Sometimes a cold may be removed by abstinence, and drinking a quantity of cold water at bedtime.

276. *Cold Feet*.—To those afflicted with nearly perpetual cold feet, I recommend that the feet be rubbed for several minutes with the hand or flesh-brush, as hard as can be borne, which will induce circulation and flow of the blood. Frequent ablutions are necessary, as the pores are often obstructed, and the facility of perspiration impeded, by those who are neglectful in this respect. When washed in cold or warm water, the feet should be rubbed until thoroughly dry, with a warm towel or flannel.

277. *Convulsions*.—These arise, in children, from several causes. Should it be from teething, which is generally the case in young children, lance the gums freely; if from what has been eaten, give an emetic; if from sour matter in the bowels, administer a laxative clyster, and a rhubarb draught.

278. *Corns*.—If the skin about the corn be very hard, rub it with nitrate of silver or liniment of ammonia, or touch it with strong nitric acid or chloride of antimony. The best thing for soft corns, between the toes, is nitrate of silver.

279. *Croup*.—The peculiar shrill sound of the cough—dry, and resembling the crow of the cock, and the hissing sound of breathing, distinctively mark this disease. It requires prompt attention to save life, by leeches or cupping. Give

an emetic of ipecacuanha, or tartarized antimonial wine; then 2 or 3 grains of calomel, every three or four hours, according to the age and strength of the patient.

Draught for Gentle Perspiration.

Camphor mixture,	1 ounce,
Liquid acetate of ammonia,	$\frac{1}{2}$ drachm,
Antimonial wine,	20 drops,
Paregoric elixir,	2 drachms.

280. *Diarrhœa*.—Administer a dose of rhubarb and magnesia, or castor oil, followed by the aromatic chalk mixture, which is generally sufficient. Mix, and take two tablespoonfuls every two or three hours, to which previously add 10 drops of paregoric elixir.

281. *Dysentery* is more common in warm climates than in cold ones. At the commencement of the attack, use warm fomentations to the stomach; give 5 grains of calomel, with 5 or 10 grains of Dover's powder, at night, and $\frac{1}{2}$ an ounce of castor oil, with 10 drops of laudanum, in the morning, followed by a starch injection. Afterwards, gentle tonics, such as bark or chamomile tea. Blackberries, in some cases, have proved extremely useful in dysentery; a syrup made from them is still better. Repeat the dose of calomel and Dover's powder for a night or two, if necessary.

282. *Embrocations*.—For inflammation of the skin, bruises, swelling of the glands, and contusions, where blood-vessels have been ruptured under the skin, a pint of good vinegar and $\frac{1}{2}$ a pint of strong spirits are found beneficial.

283. *For Lumbago, Gouty Pains, and Rheumatism*, the following is often highly beneficial:

Soap liniment,	2 ounces,
Spirit of camphor,	1 ounce,
Oil of thyme,	2 drachms,
Tincture of opium,	1 drachm.

284. *Emetics*.—Medicines given to produce sickness, or to nauseate the stomach. Example—Solution of Tartarized Antimony :

Emetic tartar, 2 grains,
Distilled water, 4 ounces.

Dissolve, and take two tablespoonfuls every fifteen minutes until sickness follows.

285. *Emmenagogues* are medicines to promote the natural functions peculiar to females :

Emmenagogue Pills.

Aloes pills, with myrrh, 1 drachm,
Compound iron pill, 1 drachm,
Carbonate of soda, 1 scruple.

Make into thirty pills; take two twice a day.

286. *Expectorants* are for the purpose of relieving the throat, lungs, and air passages from an accumulation of mucus.

Mixture.

Ipecacuanha wine, 1 drachm,
Sweet spirit of nitre, 2 drachms,
Syrup of squills, 6 drachms,
Camphor water, 3 ounces.

Mix, and take a tablespoonful when the cough is troublesome.

287. *Fits*.—First rub the temples with ether. As soon as swallowing can be performed, give sal volatile and spirit of lavender, in water, a little ether, or, if nothing else is at hand, a little weak brandy and water, cold.

288. *Freckles*.—You may generally remove freckles from the face without using cosmetics. One of the best and easiest recipes is: a teacupful of soured milk, cold, and a small quantity of scraped horse-radish. Let this stand from six to twelve hours; then use it to wash the parts affected, two or three times a day.

289. *Heartburn*.—Should this proceed from acidity of the stomach, its immediate effects may be removed by magnesia or ammonia, and if costiveness exists, a little rhubarb should be taken at the same time; after which, some stomachic, a little carbonate of soda, with a teaspoonful of tincture of cardamoms, in water.

290. *Hiccup*.—This may often be removed by holding the breath, by swallowing a piece of bread, or by a sudden fright. A little rhubarb and chalk will remove it. Should it proceed from irritability of the nerves, take a few drops of sal volatile, with a teaspoonful of paregoric elixir. Sip a glass of cold water, with a little carbonate of soda dissolved in it.

291. *Hooping Cough* is easily distinguished by the peculiar hoop when the child draws in its breath. Change of air has often effected a cure when the disease obstinately resisted medicines. Promote expectoration, or an emetic may be given occasionally of ipecacuanha wine every other night.

292. *Indigestion*.—First avoid the cause of diet; correct acidity with alkalis, that is, $\frac{1}{2}$ a teaspoonful of magnesia, carbonate of soda, or a wine glass of lime water with milk; purge with calomel and colocynth. Drink soda water, toast and water, or brandy and water occasionally. The greatest attention should be paid to the diet. Plenty of exercise, good open air, and muscular exertion, will generally prevent attacks of indigestion.

293. *Itch*.—This is easily known by the pimples on the wrist, fingers, hands, and waist, and is caused by a minute insect getting under the skin. Milk of sulphur is taken internally, and the body rubbed with the following sulphur ointment every night; it is made with—

Powdered sulphur, 1 ounce.

“ black pepper, 1 drachm.

Hogs' lard,	3 ounces.
Essence of bergamot,	1 drachm.

294. *Inflammation of the Liver.*—There is first a chilliness, then a pain in the right side, extending up to the shoulder bone, which is felt more acutely when the part is pressed. A cough, sallow complexion, and ease only found in lying on the affected side, vomiting of bilious matter, saffron-colored urine, are the early symptoms. Purge with calomel and jalap every night till the inflammation has ceased.

295. *Measles.*—This is a contagious fever, and comes on with sickness, fever, shivering, pain in the head, and cough; the eyes are heavy, swelled, inflamed, and water runs from them and the nostrils, with a great disposition to sleep. Give cooling and aperient medicines, with spare diet, principally of a farinaceous kind, and keep in mild temperature. Simple diaphoretics, to cause perspiration, do good. Paregoric elixir, in small quantities, occasionally.

296. *Palpitation of the Heart.*—This often arises from some organic affection. Avoid all excitement and violent exercise. When from biliousness, take 5 grains of blue pill at bedtime, and a rhubarb draught. Low diet, repose, and quietude of mind, improve the digestion and general health.

297. *Pectorals.*—Those that allay and soothe in cough, &c., are oils of almonds, olives, and aniseed, honey, spermaceti, liquorice, linseed, and compound powder of tragacanth. The balsamic are, balsam of Peru and Tolu, benzoin and sulphur. The sedatives are, paregoric elixir, syrup of poppies, &c.

298. *Pimples.*—A weak solution of sugar of lead or sulphate of zinc may be used as a wash.

299. *Pleurisy.*—This is felt as an acute pain on one side near the ribs, extending to the shoulder blades, back, and

breast. There is difficulty in breathing, red cheeks, sickness, and dry cough. Bleed from the arm as much as the person can bear, or until the pain is relieved; then give a dose of tartar emetic or antimonial wine, followed by 5 grains of calomel and an aperient draught, a mustard poultice, and if necessary, blisters.

300. *Ringworm*.—When crusts appear on the head, of a bright yellow color, in patches or round rings. It is contagious, and generally goes through a small family. Have the head washed daily, and use a lotion of 10 grains of caustic potash to 1 ounce of vinegar and water.

301. *Scurvy*.—Take vegetable food of every description, fruits, oranges, lemons, lime water, lemon juice, and nitre dissolved in vinegar, cider and citric acid, gentle aperients, such as epsom salts. Tamarind drink is efficacious.

302. *Sea-sickness*.—An occasional draught of ginger-beer powders, soda and seidlitz powders, a few drops of laudanum on sugar, or half a teaspoonful of sal volatile in water, are beneficial.

303. *Spitting of Blood*.—Try a tablespoonful of salt, low diet, and take nothing heating. Avoid exertion, refrain from conversation, remain in a lying position, and keep perfectly quiet. Keep ice in the mouth, and use tamarind and cold drinks; nitre acidulated is beneficial. The following pills are infallible:

Sugar of lead,	2 grains.
Extract of henbane,	5 “
Dovers powders,	12 “.

Make four pills, one to be taken every hour.

304. *Stomachics*.—The following tonics are used: Gentian, chamomile, orange and lemon peel, rhubarb, and tonic pills made of

Sulphate of iron,	10 grains.
Extract of gentian,	$\frac{1}{2}$ drachm.

Aloes, 1 drachm.

Make into thirty pills, and take two daily before dinner.

305. For *Intermittent Fevers* the following powder may be used :

Peruvian bark, $\frac{1}{2}$ ounce.

Epsom salts, 3 drachms.

Make into four powders.

CHAPTER IV.

A LIST OF APPROVED HOUSE REMEDIES AND NOSTRUMS.

306. *Compound Arnica Tincture*, for bruises of all descriptions.

- 1 ounce of tincture of arnica.
- 4 " Goulard water.
- $\frac{1}{2}$ " laudanum.

307. *Balm of Gilead*.—This once celebrated English universal remedy, principally called for by the nobility, is composed of

- 1 ounce of compound tincture of cardamoms.
- $\frac{1}{4}$ " tincture of cantharides.

308. *Bacher's Tonic Pills* are composed of equal quantities of extract of hellebore and myrrh.

309. *Balsam Honey*.

- 4 ounces of gum benzoe.
- 1 " " styrax.
- 8 " honey.
- 3 pints of alcohol.

Let it digest for a week.

310. *Balsam Horehound*, for colds and asthma.

Make an infusion of liquorice root and horehound herb, equal quantities, 1 pint of hot water, and add laudanum, camphor, flowers benzoin, squills, essence of aniseed oil, each 1 drachm, and honey $1\frac{1}{2}$ pounds.

311. *Balsam of Liquorice* is a mixture of paregoric and oil of anise.

312. *Barclay's Anti-bilious Pills*.—The following English receipt is exact :

- 2 drachms of extract of colocynth.
- 1 " " jalap.

1½ drachms of soap.
 3 " guajac.
 8 grains tartar emetic.
 4 drops each of oils of juniper, caraway and
 rosemary.

Make pills with buckthorn syrup, three grains each.

313. *Bateman's Drops*.—Make a tincture of

½ ounce of camphor.
 ½ " powdered opium.
 ½ " " catechu.
 2 drachms of castor.
 1 " oil of anise.
 5 gallons of alcohol.

314. *Bates' Anodyne Balsam*.

1 part laudanum.
 2 " soap liniment.

315. *Bland's Female Pills*.

1 drachm of sulphate of iron.
 2 " salts of tartar.
 2 " powdered liquorice.
 2 " gum tragacanth.

Make into pills, with extract of gentian.

316. *For Bowel Complaints*.—Make a mixture of

2 drachms of carbonate of magnesia.
 1 " laudanum.
 6 " tincture of rhubarb.
 1 " powdered "
 12 drops of oil of anise.
 24 " essence of peppermint.
 6 ounces of water.

317. Or the usual *Chalk Mixture*, composed of

2 drachms of prepared chalk.
 2 " powdered gum arabic.
 1 " laudanum.

6 drachms of water.
 2 " tincture of kino.

318. *Camphor Julep*, for the same purpose.

1 ounce of tincture of camphor, rubbed up with
 white sugar and gum arabic; then dissolve in
 1 pint of boiling water.

A tablespoonful is a dose.

319. *Chamberlin's Restorative Drops*.

Essential oil of chamomile dissolved in alcohol.

320. *Chilblain Liniment*.

To 3 drachms of white vitriol,
 2 " camphor,
 Add 1½ " sugar of lead,
 1½ " muriatic acid,
 4 pounds of water,
 2 drachms of red lavender.

321. *Ching's Celebrated Worm Lozenges* consist of yellow and brown lozenges. The former are directed to be taken in the evening; the latter, the succeeding morning.

To prepare the yellow lozenges, take

½ ounce of saffron.
 1 pint of water, to the strained infusion.

Add 1 pound of calomel (washed in alcohol), and
 28 pounds of sugar and gum tragacanth mucilage;
 making a mass for lozenges, so that each
 lozenge shall contain 1 grain of calomel.

The brown lozenges are prepared thus—

7 ounces of calomel.
 3½ " resin jalap.
 9 pounds of white sugar and gum tragacanth mu-
 cilage, so as to contain ½ grain of calomel.

322. *Concentrated Solution of Charcoal*.—An English patent medicine for astringency.

Take a weak tincture of catechu.

323. *Count Warwick's Purgative Powder* consists of scammony, crude antimony, and cream tartar, and is highly recommended in intermittent fever.

324. For *Costiveness* the following pill is effectual—

- 1 grain of aloes.
- $\frac{1}{2}$ “ extract of colocynth.
- $\frac{1}{2}$ “ powdered ginger.
- $\frac{1}{2}$ “ “ myrrh.

Make three grain pills, and take one morning and evening.

325. *Dalby's Carminative for young Babies*.—The genuine English receipt.

- 1 drachm of carbonate magnesia.
- 2 ounces of peppermint water.
- $\frac{1}{2}$ ounce of poppy syrup.
- 2 drops of oil of caraway.
- 2 “ “ peppermint.

326. *De la Motte's Golden Drops for Women*.—An æthereal solution of muriate of iron.

327. *Ditchett's Spanish Pile Ointment*.—A universal remedy, and very efficacious.

- 1 ounce of sugar of lead.
- 1 “ sulphate of zinc.
- $\frac{1}{2}$ “ laudanum.
- 8 “ water.

328. *British Oil*.

- 2 ounces of oil of spike.
- 3 “ “ amber.

329. *Dovers Powders*, to soothe pains and produce sleep.

- 2 drachms of fine saltpetre.
- 12 grains of powdered opium.
- 12 “ “ ipecac.

Divide the whole into twelve powders.

330. *Essence of Life* (German).—A bitters kept almost in every house, for giving an appetite.

- Digest 1 quart alcohol,
 1 " water,
 1 " Malaga wine,
 and the following vegetables :
- 1½ ounce of quassia wood.
 - 1 " orange peel.
 - 1 " rhubarb.
 - ½ " orange buds.
 - ½ " aloes.
 - 6 drachms of gentian.
 - 2 " zedoary and elecampane.
 - 2 " saffron and myrrh.

331. *Extract Milk* for long voyages.—Evaporate the milk until near to dryness, and add ½ part of white sugar to it.

332. *Fever and Ague Remedies.*

½ ounce of quinoidin is dissolved in
 4 ounces of pure spirit, and added to a tincture
 of cardamom, calamus, and ginger.

333. *Fever Pills.*

- 1 drachm of sulphate of quinine,
- ½ " Prussian blue,
- 10 grains of tartar emetic.

Make 3 grain pills, with extract of gentian, and take 2 pills three times a day.

334. *Fever and Ague Plaster.*—This plaster is applied on the forearm of the patient and left fifteen or twenty days, and is said to remove entirely the fever and ague. It is prepared with

- 10 parts of powdered myrrh,
- 10 " soft turpentine,
- 2 " gum olibanum,
- 2 " aloes,
- 2 " Peruvian balsam,

Mix and heat in a pan, and then spread on leather.

335. *Quinine Pills* of an approved recipe.

12 grains of quinine,
 2 " blue vitriol,
 2 " powdered opium,

Made with gum-arabic, powdered, into 12 pills, and take 1 pill twice a day.

236. *Fever Draught* or *Saline Mixture*, an efficient diaphoretic.

1 drachm of sal tartar, dissolved in
 4 ounces of water; and add
 2 ounces of the juice of lemons.

If you please, add about a $\frac{1}{2}$ of an ounce of the tincture of cardamom, in order to allay irritation of the stomach.

337. *For Flatulence*.—Take a teaspoonful of table-salt several times a day.338. *Fluor Albus*.—Make a powder of

10 grains of powdered gum olibanum,
 10 " orange peel,
 3 " oak bark.

339. *Fluid Magnesia*, a simple drink and highly beneficial. To

1 gallon of soft water, add
 $\frac{1}{2}$ ounce of carbonate of magnesia,
 4 ounces of sugar,
 4 " Epsom salts.

Force into the solution sufficient carbonic acid gas equal to ten times its bulk.

340. *Fothergill's Pills*, a powerful antifebrile pill.

Aloes, scammony, extract of colocynth, and oxyde of antimony, equal parts of each.

341. *Godfrey's Cordial*.—Digest

1 gallon of water,
 1 pound of alcohol,
 1 " sassafras bark,

1 pound of angelica seed,
6 ounces of opium.

342. *Goulard's Lotion* was formerly used as a cosmetic, and is prepared by an emulsion of bitter almonds; and to each ounce of emulsion add $1\frac{1}{2}$ grains of corrosive sublimate and a little spirit of rosemary.

343. *Guy's Anthelmintic Powder*, is an alloy of rasped tin, mercury, and sulphur rubbed up together, and has proved very effectual in destroying worms.

344. *Hannay's Lotion*, or the most celebrated preventive water, is a solution of caustic potash in water.

345. *For Heartburn*.—Take a few grains of bicarbonate of potash in a solution of fluid magnesia, or by itself.

346. *Hill's Essence of Bandana* is a tincture of 1 ounce of guajac in 3 ounces of spirits.

347. *Honey Water*, a handkerchief perfume.—It is a mixture of oil of jasmine and other oils dissolved in alcohol.

348. *Hooper's Female Pills*.—They are composed of aloes, myrrh, sulphate of iron, and canella alba, made black by ivory-black, and formed into pills.

349. *Hungarian Water* is a mixture of spirits of lavender and rosemary.

350. *For Hydrophobia*.—This antiquated remedy is made of

2 ounces of prepared chalk,
2 " gentian root,
1 " bole Armenia,
 $\frac{1}{2}$ " powdered myrrh.

Taken with bolus tea morning and evening.

351. *For Indigestion*.—The digestive tableta, or lozenges, are prepared from

1 ounce of white sugar,
1 drachm of rhubarb,
1 " bicarbonate of soda,

$\frac{1}{2}$ drachm of ginger powder,
 $\frac{1}{2}$ " cardamom seed.

352. *Jesuits' Drops*.—They are composed of tincture of guajac, balsam copaiva, and oil of sassafras.

353. *Hooping-cough Tea*.—Composed of equal quantities of marshmallow root, liquorice root, bitter-sweet root, chamomile, and fennel seed.

354. *Keyser or Dutch Pills*.—A universal German pill, in small red boxes. They are composed of acetate mercury in combination with manna, and made into 1 grain pills.

355. *Lady Webster's Dinner Pill*.—This is a very useful family pill, and has acquired great celebrity in England.

6 drachms of aloes,
 2 " gum mastic,
 2 " red roses.

All powdered, and made into 3 grain pills with the syrup of wormwood.

356. *Mathews' Injection for Fistula in Ano*.—It is a diluted tincture of cantharides in enema.

357. *Minderer Spirit*, the most useful and necessary house-remedy in colds and in fever stages, so as to produce perspiration. It is easily prepared. Take 6 ounces of vinegar; add sal ammonia, say 1 ounce. A tablespoonful is given to the patient every two hours.

358. *Morrison's Hygeinic Pills*.—They are composed of

1 drachm of gamboge,
 $\frac{1}{2}$ " jalap,
 $\frac{1}{2}$ " aloes,

20 grains of Turpith's mineral.

359. *Nervous Cordial* (Brodrum's).—It consists of equal quantities of the tincture of gentian, columbo, cardamom bark and wine, iron, and compound tincture of lavender.

360. *For Palpitation of the Heart*.—The best remedy is

the ether cordial, prepared by adding to syrup of gum some sulphuric ether, and administering a teaspoonful occasionally.

361. *Peters' Pills* are composed of equal parts of aloes, jalap, scammony, and gamboge, and half the quantity of calomel.

362. *Pile Ointment.*

2 drachms of powdered gall,
 $\frac{1}{2}$ " of Goulard's lotion,
 2 " of laudanum.

363. *Racahont des Arabes.*—This celebrated French preparation for diet is prepared from cocoa, rice-flour, and sugar.

364. *For Rheumatism*, the following is a valuable medicine: dissolve 24 grains of hydriod. potash in 8 ounces of water, and add 1 ounce of ginger syrup.

355. *Roche's Embrocation*, for hooping-cough, consists of

1 ounce of olive oil,
 $\frac{1}{2}$ " of amber,
 $\frac{1}{2}$ " of cloves.

366. *Roob Antisyphilitic* is the same as the famous Sirop de Cuisinier, and is prepared from sarsaparilla root, burrage flowers, white roses, aniseed, sugar and honey to form a syrup; and add, at last, one grain of corrosive sublimate to the pint of syrup.

367. *Restorative for Scrofula and Scurvy.*—Prepared by a mixture of cinnabar, sulphur, sulphate of lime, and gum arabic.

368. *Sore Throat (Quinsy).*—Gargling with a solution of alum.

369. *Spider Webbing*, said to be the best febrifuge.

PART III.

POLYTECHNY, ETC., ETC.

CHAPTER I.—METALLURGY.

ALLOYS AND METALS.

370. *Alloy for Writing Pens.*

- 4 parts of platina,
- 3 “ of silver,
- 1 “ of copper.

The pens made from this composition are far better than steel, as it does not oxydize, and is more elastic than either gold or silver.

371. *Imitation Silver.*—Take

- 11 ounces of refined nickel,
- 2 “ of metallic bismuth.

Melt the composition three times, and pour them out in ley; the third time, when melting, add 2 ounces of pure silver.

372. *Imitation Gold.*

- 4 ounces of platina,
- 3 “ of silver,
- 1 “ of copper.

373. *The New Gold (Orite).*—To 100 parts of copper, melt, with 6 parts of magnesia, $3\frac{1}{2}$ parts of sal ammonia, $1\frac{8}{10}$ parts of quicklime, and 9 parts of crude tartar (cream of tartar); and, when fusing for some time, add 17 parts of zinc, and stir it quickly.

374. *Tough and Elastic Platina.*—To 1 ounce of platina

scraps, add $\frac{1}{100}$ part of steel. If $\frac{1}{500}$ part of steel are added, it will be suitable for cutting-instruments. If equal parts of platina and steel, a very white, ductile alloy is obtained, capable of taking a high polish. If 8 parts of steel are added to 1 part of platina, it forms the best material for mirrors.

375. *Gold Imitation.*

16 parts of copper,
7 " of platina,

melted with borax and charcoal, and 1 part of zinc added.

376. *Alloy for Writing Pens*, which resist the action of ink.

4 parts of platina,
3 " of silver,
1 " of copper.

377. *Copper Amalgam for Dentists.*

3 parts of copper,
7 " of mercury.

378. *German Silver for Sheet.*

20 parts of nickel,
60 " of copper,
20 " of zinc.

379. *German Silver for Castings.*

1 pound of nickel,
3 pounds of copper,
4 " of zinc,
 $1\frac{1}{2}$ ounces of lead.

380. *White and Soft Metallic Composition.*

44 ounces of steel,
 $4\frac{3}{4}$ " of nickel,
 $3\frac{3}{4}$ " of antimony,
 $\frac{1}{2}$ " of cream of tartar.

381. *White Metal*, instead of tin itself.

32 parts of tin,
3 " of copper, which has been previously soaked in vinegar, sal ammonia, and pitch.

382. *White Metal for Casting and Rolling.*

55 parts of copper,
33 " of nickel,
17 " of zinc,
3 " of iron,
2 " of tin.

383. *Metallic Pencils, for writing on paper.*

70 parts of lead,
30 " of bismuth,
8 " of quicksilver

CHAPTER II.

AMBROTYPE CHEMICALS.

The apparatus required for the ambrotype process is copied from Burgess's "Ambrotype Manual."

1. A bath of gutta percha or glass.
2. A dipping rod of gutta percha or glass.
3. A flat dish for fixing solutions, either of gutta percha, earthenware, or glass.
4. A large earthen dish for the developing solution.
5. A bottle for the developing solution, capable of holding two quarts.
6. A four or six ounce graduated glass.
7. A large bottle with glass stopper, capable of holding more than the quantity of nitrate of silver solution contained in the bath.
8. Several glass or gutta percha funnels.
9. An hydrometer for testing the strength of the nitrate of silver bath.
10. A plate frame for holding the glass plates when placed in the camera.
11. A pair of scales, with weights.
12. Cotton and filtering paper.

The Chemicals for the Ambrotype.

1. Nitrate of silver, pure, in crystals.
2. Protosulphate of iron.
3. Acetic acid.
4. Alcohol, 95 per cent.
5. Cyanide potassium.

6. Hyposulphide of soda.
7. Iodized collodion.
8. Nitric acid, chemically pure.
9. Glacial acetic acid.
10. Litmus paper, blue and red.
11. Iodide of potassium.
12. Carbonate of soda.

• *The Varnishes required for the Ambrotype Process.*

1. White varnish.
2. Black “
3. Amber “
4. Gum damar varnish.
5. Canada balsam.

I. *Nitrate of Silver Bath.*—Dissolve 40 grains of pure nitrate of silver in 1 ounce of distilled water. A quart bottle requires $5\frac{1}{2}$ ounces of the silver.

II. *The Iodide of Silver* is prepared of iodide of potassium, by using 12 grains of the latter dissolved in 1 ounce of water, to 2 drachms of the nitrate of silver. The washed precipitate is added to a solution consisting of 1 ounce of nitrate of silver to 6 ounces of water. The whole quantity made up to 2 quarts is sufficient for the bath.

III. *The Developing Solution* is prepared from

- 3 ounces of sulphate of iron,
- 3 “ common acetic acid,
- 3 “ alcohol,
- 1 quart of water.

IV. *The Fixing Solutions.*

No. 1. $\frac{1}{2}$ ounce cyanide of potassium.

1 pint of water.

No. 2. 4 ounces of hyposulphide of soda.

1 pint of water.

V. Preparation of Gun Cotton.

6 ounces of powdered nitrate of potash.

5 " pure sulphuric acid.

160 grains of pure cotton.

It requires attention in preparing properly the gun cotton, so as to produce a good collodion from it.

VI. Preparation of the Collodion.

10 ounces of pure concentrated ether.

6 " alcohol, 95 per cent.

80 grains of gun cotton.

This will make a perfect solution.

VII. Iodized Collodion.

8 ounces of pure collodion.

4 drachms of bromo-iodide of silver.

20 drops of hydrobromic acid.

VIII. Bromo-iodide of Silver is prepared by mixing the solution of

80 grains of bromide of potassium, and

80 " nitrate of silver.

IX. Hydrobromic Acid.

4 ounces of alcohol, 95 per cent.

1 ounce of distilled water.

1 drachm of pure bromine.

To be left standing twenty-four hours, and then add again 5 or 6 drops more of bromine, for eight or ten days, and it is then ready.

X. Gum Damar Varnish.

$\frac{1}{2}$ ounce of gum damar.

2 ounces of chloroform.

Shake the mixture for two or three days.

XI. Asphaltum Varnish is prepared by dissolving asphaltum and spirits of turpentine.

XII. White Varnish, of gum shellac and copal.

1 ounce of New Zealand gum.

$\frac{1}{2}$ ounce of gum shellac.

$\frac{1}{2}$ " gum copal.

All finely powdered and dissolved in 95 per cent. alcohol.

XIII. *Highly sensitive Collodion.*

Add 3 drops of iodide of iron dissolved in alcohol,

To 1 ounce of iodized collodion.

XIV. *Collodion for Negatives.*

8 ounces of collodion.

40 grains of iodide of ammonium.

16 " bromide "

XV. *Developing Solution for Negatives.*

2 ounces of protosulphate of iron.

2 " acetic acid.

1 ounce each of alcohol and water.

XVI. *Preparation of Toning or Coloring Bath.*

16 ounces of distilled water.

4 " hyposulphide of soda.

50 grains of nitrate of silver.

15 " chloride of gold.

XVII. *Chloride of Gold Bath.*

15 grains of chloride of gold.

60 " hyposulphide of soda.

1 pint of water.

XVIII. *Preparation of Sel d' Or.*—It is a hyposulphide of gold, produced by the reaction of chloride of gold.

1 drachm, in solution.

$\frac{1}{2}$ ounce of hyposulphide of soda.

Crystallize the same with great caution.

XIX. *Ambrotype Colors* are—

Venetian or Indian red,

Chrome green,

" yellow,

Chinese blue,

Purple a mixture of Venetian red and blue.

The chemicals used in the Daguerreotype and Photographic processes are very numerous; but nearly all of them are used also in the Ambrotype process, with the exception of the mercury box, in which the picture is received from the camera, after having been exposed to the iodine and bromine vapors. Another apparatus different from the Ambrotype is the polishing wheel and polishing materials for the silvered plates.

CHAPTER III.

ARTIFICIAL GUANO OR FERTILIZER.

414. *Artificial Guano.*

- . 25 pounds of bone dust.
- 20 " urine.
- 10 " sulphate of soda.
- 5 " " ammonia.

415. *Another Guano.*

- 1 bushel bone dust.
- 10 pounds of sulphate of ammonia.
- 10 " " soda.
- 2 " " iron.
- 5 " salt.
- 10 " dried blood.

416. To 1 bushel of bone black,

- 10 pounds of sulphate of ammonia.
- 5 " nitrate of soda.
- 20 " dry blood.

417. To 1 bushel of pulverized bones,

- 20 pounds of oil of vitriol.
- 10 gallons of gas-house liquor.
- 10 pounds of sulphate of soda.
- 1 bushel of street dirt.
- 5 gallons of urine.

418. *Peruvian Guano.*

- 100 " plaster of Paris.
- 20 " sulphate of ammonia.
- 12 " saltpetre.
- 1 bushel of bone dust.

419. To 100 pounds of fresh blood,
 20 " calcined plaster.
 12 " sulphate of soda.
 5 " sulphuric acid.

420. *Testing the Guano.*—Burn $\frac{1}{2}$ ounce of the best Peruvian guano in an iron ladle, and it should leave 1 drachm of ashes.

421. By washing $\frac{1}{2}$ ounce of guano with boiling water until the water runs off clear. Dry and weigh the residue: if it weighs but 50 per cent., it is a fair quality; if 80 or 90, it is a poor quality.

422. Good guano must weigh from 65 lbs. to 73 lbs. to the bushel; while adulterated guano weighs upwards of 116 lbs.

ARTIFICIAL GUM ARABIC.

This valuable substitute for gum arabic is prepared from

- 100 parts potato starch.
 20 " sago.
 20 " wheat starch.
 20 " barley flour.

Add six times as much water as the weight of potato starch, and heat in a water bath until the whole mass becomes uniform. Strain through a woollen cloth, and dry by evaporation all the water from it.

CHAPTER IV.

ARTIFICIAL PRECIOUS STONES

424. *The Strass*, the basis for all pastes, but which is very hard and gives sparks when rubbed on steel.

1 ounce of powdered glass,
 3 drachms " quartz,
 3 " " red lead,
 2 " burnt borax,
 40 grains of saltpetre,
 30 " white arsenic.

This composition is exposed to a white heat in a covered crucible for thirty hours.

425. *Ruby*.

1 ounce of powdered rock-crystal or quartz,
 $\frac{1}{2}$ " dried carbonate soda,
 4 drachms of burnt borax,
 $1\frac{1}{2}$ " saltpetre,
 3 " red lead,
 15 grains of cassius purple,
 8 " metallic antimony,
 8 " oxyde manganese.

426. Or by taking

1 ounce of powdered rock-crystal,
 $\frac{1}{2}$ " dry carbonate soda,
 80 grains of burnt borax,
 40 " saltpetre,
 15 " purple cassius,
 1 drachm of sal ammonia.

427. *Sapphire.*

Take $1\frac{1}{2}$ ounces of ground rock-crystal,
 6 drachms of dry soda,
 2 " " borax,
 2 " red lead,
 1 " saltpetre,
 1 grain of carbonate cobalt.

428. Or mix 1 ounce of rock-crystal,

$\frac{1}{2}$ " dry soda,
 3 drachms " borax,
 $1\frac{1}{2}$ " of red lead,
 $\frac{1}{2}$ " saltpetre,
 $\frac{1}{4}$ grain of carbonate cobalt,
 15 " " copper.

429. By means of the carbonate of copper.

$1\frac{1}{2}$ ounces of rock-crystal,
 6 drachms of soda,
 1 " borax,
 1 " red lead,
 $\frac{1}{2}$ " saltpetre,
 $\frac{1}{2}$ " carbonate of copper.

430. *Emerald.*

Take $1\frac{1}{2}$ ounces of rock-crystal,
 6 drachms of dry soda,
 2 " " borax,
 2 " red lead,
 1 " saltpetre,
 20 grains of red oxyde of iron,
 10 " green carbonate of copper.

431. *Green Color.*

$1\frac{1}{2}$ ounces of rock-crystal,
 $\frac{1}{2}$ ounce of dry soda,
 2 drachms of dry borax,
 2 " red lead,

40 grains of saltpetre,
 1½ " carbonate cobalt,
 10 " " chrome.

432. *Canary.*

9 drachms of rock-crystal,
 3 " dry soda,
 2 " red lead,
 1 " saltpetre,
 80 grains of oxyde of uranium,
 3 " carbonate of copper,
 3 " oxyde of tin,
 3 " white burnt bone-ashes.

433. *Chrysoprase.*

1½ ounces of rock-crystal,
 ½ ounce of dry soda,
 3 drachms of burnt borax,
 2 " red lead,
 20 grains of saltpetre,
 2 drachms of white bone-ashes,
 2 grains of carbonate of copper,
 4 " red oxyde of iron,
 6 " oxyde of chrome.

434. *Opal.*

9 drachms of rock-crystal,
 3 " dry soda,
 2 " burnt borax,
 1½ " red lead,
 15 grains of saltpetre,
 1/10 " cassius purple,
 1½ " bone-ashes,
 2 " muriate silver.

435. *Aqua Marine.*

1½ ounces of rock-crystal,
 ½ ounce of dry soda,

- 3 drachms of burnt borax,
 2 " red lead,
 1 " saltpetre,
 6 grains of red oxyde iron,
 2 " carbonate of copper.

436. *Hyacinth*.—The above mixture, with the addition of ten grains of oxyde of manganese.

437. *Granat*.

- 9 drachms of rock-crystal,
 3 " dry soda,
 2 " burnt borax,
 1½ " red lead,
 40 grains of saltpetre,
 5 " oxyde of manganese,
 3 " " iron,
 1 " cassius purple.

438. *Rubellite, Red Tourmaline*.

- 1 ounce of rock-crystal,
 ½ " dry soda,
 3 drachms of burnt borax,
 1½ " red lead,
 1½ " saltpetre,
 8 grains of oxyde of nickel.

439. *Indigolite or Indigo Blue Tourmaline*.—The above mixture with the addition of the carbonate of cobalt.

440. *Chrysolite*.

- 6 drachms of rock-crystal,
 2 " dry soda,
 1½ " burnt borax,
 1 " red lead,
 10 grains of saltpetre,
 2 " oxyde of manganese.

441. *Amethyst*.

But 1 grain of the oxyde of manganese to each ounce of the mass.

442. *Turquoise.*

To the above mixture use instead of the manganese,

5 grains of dry verdigris,
 3 " powder blue,
 20 " bone-ashes.

443. *Lazulite.*

By adding to former mixtures,

2 grains oxyde cobalt,
 1 drachm of burnt bone-ashes.

444. *Agate.*

By mixing together several frits and adding oxyde of iron, several varieties of agate are obtained.

445. *Cleaning Powder for Precious Stones.*—The best mixture is the precipitated sulphur, which is put on a fine brush, or by mixing

$\frac{1}{2}$ ounce of flowers of sulphur,
 1 " fine Tripoli,

which powder is rubbed on leather and used for cleaning the stones.

CHAPTER V.

MISCELLANEOUS RECEIPTS.

BLACKING.

446. *Blacking for Boots.*

3 pounds of ivory-black,
 2½ “ molasses,
 ¾ “ fish oil,

stirred up with 1 quart of hot water; and add 2 ounces of gum-arabic, and as much oil of vitriol as will make a thick paste.

447. *Gloss Blacking for Harness.*

4 pounds of blood,
 1 pound of spirits of wine,
 rubbed up with fresh calcined lampblack.

BLEACHING:

448. *Bleaching of Shellac.*—By dissolving common shellac in sal soda, and then adding muriatic acid, the shellac is readily bleached.

449. *Bleaching of Sponge.*—Washing the sponge with soda lye repeatedly, and putting them in a box in which the chlorine gas (prepared from the manganese and muriatic acid) is conducted, the sponges are readily bleached.

450. *For Bleaching Wool, Straw, and Feathers.*—The sulphurous acid gas, obtained by throwing sulphuric acid on charcoal, and heating in a retort to obtain the gas.

BOTTLE AND SEALING WAX.

451. *Bottle Wax.*

2½ pounds of hard turpentine,
1½ “ rosin,

and an addition of a little linseed oil, and coloring either by vermilion, chrome yellow, or green vermilion, or chrome green.

452. *Sealing Wax, Black.*

1 pound of shellac,
¾ “ thick turpentine,
5 pounds of black (lampblack),
¾ pound of prepared chalk.

453. *Fine Sealing Wax, Red.*

1 pound of shellac,
¾ “ Venice turpentine,
½ “ red lead,
½ “ prepared chalk.

454. *Best Sealing Wax, Red.*

1 pound of shellac,
1 “ Venice turpentine,
½ “ chalk,
½ “ vermilion.

CEMENTS AND PASTES.

455. *Diamond Cement for Mending Glass and China.*

4 parts of isinglass dissolved in spirits.
½ “ gum-ammonia,
½ “ “ galbanum,
2 “ “ mastic dissolved in alcohol.

456. *Slaked Lime with the White of an Egg, in glue, is a very good cement.*

457. *Stephenson's Steampipe Cement.*

- 2 parts of litharge,
- 1 part of slaked lime,
- 1 " fine sand,

to be prepared with hot glue

458. *Stone Cement.*

- 8 parts of pitch,
- 6 " rosin,
- 1 part of wax,
- $\frac{1}{2}$ " gypsum.

459. *Another Stone Cement.*

- 3 parts of sulphur,
- 2 " white rosin,
- $\frac{1}{2}$ part of shellac,
- 1 " mastic,
- 1 " gum-arabic,
- 3 parts of brick dust.

460. *Iron Cement.*

- $\frac{1}{2}$ part of sulphate of lead,
- 24 parts of powdered manganese,
- 13 " linseed oil,

461. *Transparent Cement.*

- 1 part of india rubber,
- 180 parts of chloroform,
- 45 " gum-mastic.

462. *Steam-resisting Cement.*

- 2 parts of fine powdered litharge,
- 1 part of " sand,
- 1 " " slaked lime,

with linseed oil.

463. *Knife and Fork Cement.*—Equal quantities of fine powdered rosin and fine powdered chalk.

464. *Glass Cement or Putty.*—Mix chalk with linseed oil so as to make a thick mass.

465. *Iron Cement.*

- 1 ounce of sal ammonia,
 $\frac{1}{2}$ " flor. of sulphur,
 8 ounces of iron filings.

For using as a cement, stir vinegar with them, and add more iron filings, fill the crevices of the iron to be cemented, and it will become hard very soon.

466. *Payen's India Rubber Cement.*—India rubber melted by heat; and when fluid, add

- 1 to 2 parts of fluid slaked lime.
 1 part of red lead.

467. *Cement for Fastening Iron in Stone.*—Equal parts of calcined plaster, iron filings, and dissolved glue.

468. *Cement for Fastening Glass on Metal and Metal on Wood.*—Melt shellac and add fine pumice stone with it.

469. *Paper Cement for Labels.*

- 2 ounces of glue, after being soaked in water,
 1 " sugar (rock-candy),
 $\frac{1}{2}$ ounce of gum-arabic.

470. *Berzelius Paste for Fastening Labels.*—Take glue and boil in vinegar; and add flour until it becomes a paste.

471. *The best Label Cement.*—Liquid silicate of soda.

472. *Soluble Glass for Cement and Paste.*

1 pound of melted sand,
 3 pounds of pearl-ashes,
 melt for 3 hours, in a crucible, dissolve the mass and filter.

473. *Another good Paste.*—Dissolve

- 1 ounce of gum-arabic,
 2 ounces of " tragacanth.

474. *Glass and Porcelain Cement.*

2 ounces of starch,
 3 " chalk made into paste with water
 and spirits,

add 1 ounce of glue,

1 " Venice turpentine.

475. *Cement for Bottles*, containing acid or volatile substances.—Melt India-rubber, and add, when fluid, some slaked lime, so as to make a soft paste which will soon become hard.

476. *Cement for luting Iron Pipes*.

5 parts of fine iron filings,

1 " of white clay, moistened with vinegar.

477. *Furniture Cement*, to fill up cracks in new or old furniture.

17 parts of beeswax,

15 " of spirits of turpentine,

1 " of powdered rosin,

1 " of Indian red.

478. *Mastic Cement*.

30 parts of sand,

70 " of lime,

3 " of litharge, or red lead, made up to a paste with linseed oil.

479. *Hydraulic Cement*.

22 parts of clay,

9 " of iron filings,

63 " of lime,

1 " of magnesia,

1 " of pearl-ashes,

10 " of powdered charcoal.

480. *Common Cement*, for cisterns, &c.

10 parts of plaster of Paris,

2 " of Glauber's salt,

4 " of clay,

4 " of lime.

481. *Tooth Cement*, for filling the cavities of hollow teeth.—Gum mastic dissolved in ether, and thickened with prepared chalk.

482. *Another Tooth-paste* is prepared from
1 drachm of finely-powdered gum mastic.
1 " of sandrac,
4 grains of opium.
Spirits to make a paste.

CHAPTER VI.

CLEANING, CLEANSING, AND CLEARING MATERIALS.

483. *Cleaning Glass Mirrors, &c.*—Wash the substances with alcohol, and use fine, powdered, prepared chalk on linen or buckskin.

484. *Another Glass Cleaner* is fine wood-ashes.

485. *Another Cleaner* is soap lye, and afterwards some alcohol.

486. *Iron and Steel Cleaner.*—Use emery and tripoli, and afterwards rub with sweet oil.

487. *Gold and Gilt-ware Cleaning Substances.*—By rubbing the ware with soap-suds and alcohol, or boiling in spirits of hartshorn.

488. *Brass and Copper Cleaner.*—Fine brick-dust and sweet oil.

489. *A very efficient Cleaner* is flowers of sulphur and chalk, moistened with vinegar.

490. *Steel and German Silver Cleaner.*—Vienna lime with a buff wheel.

491. *Silver-ware Cleaner.*—Fine pumice stone and prepared chalk, mixed together.

492. *Paint Cleaner.*—Spirits of hartshorn will clean the spots on oil paint.

493. *Jewellers' Polishing Powder.*—Equal parts of white lead (cremnitz white), prepared chalk, magnesia, white pipe-clay, and rouge.

494. *English Polishing Powder.*—Equal parts of crocus martis and rotten stone.

495. *French Plate Glass Cleaner.*—Equal parts of polishing putty (oxyde of tin), fine pumice, and rotten stone.

496. *French Polishing Powder*, for all metals.

7 parts of rouge,
20 " of magnesia.

497. *Brass Polish*.

1 ounce of beeswax,
4 ounces of spirits of turpentine,
4 " of sweet oil,
8 " of alcohol,
1 ounce of rotten stone.

498. *Furniture Polish*.

8 ounces of linseed oil,
 $\frac{1}{2}$ ounce of muriatic acid,
 $\frac{1}{2}$ " of alcohol.

499. *Cleansing Materials*, as used generally at the woollen factories, are: sour milk, ox gall, raw potatoes, wheat bran, cows' dung, horse chestnut, salt sorrel, soap wort.

CLEARING SUBSTANCES FOR COFFEE, CIDER, AND WINES.

500. *Wine and Beer Clearing Powders*.

3 parts of dried white of eggs,
1 part of dried blood.

501. *General Clearing Mixture*.

5 pounds of dry blood,
 $1\frac{1}{2}$ " of bone-dust, or rasped horn,
 $1\frac{1}{2}$ " of pipe-clay.

502. *Another Clearing Mixture* is:

2 parts of dry blood,
2 " of bone-black,
1 " of rasped horn.

502a. *Clearing the smell of Naphtha*, so as to make it fit for burning.—Stir into the cask, containing the naphtha which has the obnoxious smell, about one pound of oil of vitriol; let it stand for one week, and then draw off the clear naphtha.

CHAPTER VII.

COLORED FIREWORKS, OR PYROTECHNICS.

503. *Red Colored Fire.*

- 3 parts of prepared chalk,
- 2 " of washed sulphur,
- 8 " of chlorate potassa.

504. *A more expensive Red Fire.*

- 40 parts of nitrate strontia, dried,
- 13 " of washed sulphur,
- 5 " of chlorate potassa,
- 2 " of charcoal.

505. *Red Fire to Burn in Rooms, and without a sulphureous smell.*

- 1 pound of dry nitrate strontia,
- $\frac{1}{2}$ " of chlorate potassa,
- $\frac{1}{2}$ " of powdered shellac.

506. *Cheap Red Fire.*

- 3 parts of sulphate strontia (native Celestine),
- 2 " of sulphur,
- 5 " of chlorate potassa.

507. *Safe Red Fire, which will not spontaneously ignite.*

- 10 parts of oxalate strontia,
- 6 " of chlorate potassa,
- 3 " of sulphur, washed and dried.

508. *Green Fire.*

- 60 parts of nitrate baryta,
- 14 " of washed sulphur,
- 40 " of chlorate potassa,
- 6 " of charcoal.

509. *Another Mixture for Green Fire.*

6 parts of nitrate baryta,
 1 part of washed sulphur,
 2 parts of chlorate potassa,
 $\frac{1}{2}$ part of charcoal.

510. *Dark Green Colored Fire.*

4 parts of powdered, crystallized verdigris,
 2 " of blue vitriol, dried,
 1 part of boracic acid.

511. *White Bengola Fire.*

24 parts of fine saltpetre,
 7 " of washed sulphur,
 2 " of red arsenic.

512. *Blue Fire.*

1 pound of saltpetre,
 $\frac{1}{4}$ " of sulphur,
 $\frac{1}{4}$ " of sulphuret of antimony,
 $\frac{1}{8}$ " of verdigris,
 $\frac{1}{8}$ " of alum, dried.

513. *Sky-blue Fire.*

1 part of powdered sal ammonia,
 8 parts of blue vitriol,

which mixture, when thrown on cotton soaked in alcohol, and ignited, emits a light of a fine blue color.

514. *Violet Color.*—Dissolve saltpetre in alcohol; soak the cotton and set it burning, and a fine violet color is produced.

FIREWORKS PREPARED FROM TWO BASES: THE CHLORATE OF POTASH-SULPHUR, AND NITRE-SULPHUR.

515. The first is composed of

79 parts of chlorate potassa,
 21 " of saltpetre.

516. The second is composed of

75 parts of saltpetre,
25 " of sulphur.

517. *White flame* is obtained from

80 parts of nitre-sulphur,
20 " of gunpowder meal.

518. For the use of theatres, calcine the saltpetre, and, while hot, throw some sulphur in it.

519. *White.*

85 parts of nitre-sulphur (3 parts nitre to 1 of sulphur),
15 " of gunpowder meal.

520. *Crimson.*

100 parts of nitrate strontia,
46 " of chlorate potassa-sulphur,
32 " of sulphur.

521. *Green.*

53 parts of chlorate potassa-sulphur,
130 " of nitrate baryta,
32 " of sulphur.

522. *Rose.*

50 parts of nitre-sulphur,
50 " of chlorate potassa-sulphur,
25 " of chalk,
8 " of gunpowder.

523. *Blue.*

50 parts of chlorate potassa-sulphur,
50 " of nitre-sulphur,
20 " of sulphate potassa,
30 " of ammoniacal copper.

CANNON ROCKET FIRES.

524. *Crimson.*

100 parts of chlorate potassa-sulphur,
30 " of carbonate strontia,
40 " of prepared chalk.

525. *Rose.*

100 parts of chlorate potassa-sulphur,
40 " of plaster of Paris.

526. *Violet.*

100 parts of chlorate potassa-sulphur,
20 " of marble dust,
20 " of burnt alum.

527. *Green.*

100 parts of chlorate potassa-sulphur,
35 " of boracic acid.

528. *Yellow.*

100 parts of chlorate potassa-sulphur,
40 " of dried soda.

529. *Blue.*

100 parts of chlorate potassa-sulphur,
40 " of ammoniacal copper,
20 " of sulphate of potassa.

530. *Light Blue.*

100 parts of chlorate potassa-sulphur,
50 " of burnt alum,

531. *Orange.*

100 parts of chlorate potassa-sulphur,
20 " of chalk,
20 " of dry soda.

CHAPTER VIII.

COSMETICS.

Under this head are comprised many articles useful in the toilet, as well as for the preservation of health.

- a. Domestic, fancy, and useful soaps.
- b. Cologne water and handkerchief perfumes.
- c. Dentifrices and tooth ingredients.
- d. Antique and Macassar oils and pomatums.
- e. Fumigating materials, for sick-rooms and churches.
- f. Depilatories.
- g. Hair dyes.
- h. Hair restorers or invigorators.

SOAPS.

533. *Cosmetic Soap*.—Dissolve white Marseilles soap in alcohol, and add a mixture of tincture of benzoe, oil of sweet almonds, and spirits of camphor. It forms an excellent compound for softening the complexion.

534. *Glycerrhine Soap*, for chapped hands.

1 pound of Marseilles soap,

Dissolve in 1 pint of alcohol.

$\frac{1}{4}$ pound of glycerrhine.

1 ounce of balsam of Peru.

Mix all together.

535. *Leconte's Tallow Soap*.—Major L. used to prepare an excellent tallow soap for his own use by saponifying

1 pound of tallow.

1 ounce of spermaceti.

$\frac{1}{2}$ pound of sal soda.

Add a few drops of oil of vitriol.

536. *Cream Soap (Crème de Neige.)*

1 $\frac{1}{2}$ pounds of sal soda.

1 $\frac{1}{2}$ " epsom salts.

3 ounces of pulverized soap.

4 pounds of starch.

Work all the materials well together to a cream, and add 1 ounce of oil of bitter almonds, and 20 drops of otto of roses.

537. *Simple Cream Soap.*

1 pound of stearin.

$\frac{1}{2}$ " potash.

Form by boiling a soap, and work it up to a creamy soap by beating.

538. *Windsor Soap.*—Melt white Marseilles soap; and when nearly cool again, add oils of caraway and bergamot sufficient to perfume it.

539. *Low's Brown Windsor Soap.*—Add to melting white soap some balsam Peru, oils of caraway, and anise.

540. *Cocoa Nut Soap.*—Boil equal parts of cocoa nut oil, oil of sweet almonds, and soda ley, with a little lard, and form a soap.

541. *Family Soap useful in every house.*—All the refuse from the table containing grease is thrown into a barrel kept for the purpose in which is contained some sal soda dissolved in water; adding a little lime. The soap is thereby constantly forming, without any boiling.

542. *Patent Soap Liquid* is a mixture of caustic soda and spirits of hartshorn.

543. *Glove Soap.*—Take camphine, and rub your kid gloves, and they will be thoroughly cleaned.

544. *Silk Soap.*—All silk goods may be washed in tea water or bran water, containing a little alum; but for a silk

which has got soiled, use a mixture of 1 pound of spirits of hartshorn, and 10 pounds of water.

545. *Detergent Soap*, for removing grease spots from silk; woollen, and cotton stuffs.

- 6 pounds of white soap.
- 1 beef's gall.
- The white of two eggs.
- 2 pounds of burnt alum.

Beat all the substances together, and keep them for twenty-four hours in a warm place.

546. *Cream Balls*.

- 3 pounds of white soap.
- 1 pound of starch.

When melted and mixed together with some orange flower water, add some oil of caraway; then roll them well into balls, or form them in round iron moulds.

546a. *Starch Polish, or Linen Gloss*.—White soap, spermaceti, and gum arabic.

547. *Chemical Whale Oil Soap*, for protecting shrubbery and vegetables from bugs and flies.

- 1 pound of whale oil foots.
- Add $\frac{1}{4}$ " flowers of sulphur.
- $\frac{1}{4}$ " gum camphor.

Mix them well together, and make suds of it. If for use, 1 pound to 5 gallons of hot water.

548. *Soap Liniment for Sprains*.—Castile soap dissolved in spirits of wine, and an addition of spirits of hartshorn.

549. *Opodeldoc*, an old useful house remedy, is prepared by dissolving

- $1\frac{1}{2}$ ounces of tallow soap,
- $1\frac{1}{2}$ " Marseilles soap,
- in 1 quart of alcohol,

Add 3 drachms of gum camphor.

When dissolved, add a few drops of oils of rosemary and

thyme, and $\frac{1}{2}$ ounce of spirits of hartshorn. The liquid should be poured in wide-mouthed vials, and it will become hard on cooling.

550. *Transparent Soap* is prepared by macerating any soap in alcohol, and adding some oils of sassafras and caraway to the fluid, and pouring it into iron moulds for making balls, or in wooden moulds; when the same, after cooling, is cut up into small bars, and receives the various appellations of honey soap, bar transparent soap, &c.

551. *Pumice and Sand Soap*.—Add to white soap, when warmed, some fine white sand and a little fine pumice stone. Mix well together, and then roll into balls.

COLOGNE WATER.

552. *Guerlin's Cologne Water.*

3	pints of alcohol.
3	drachms of oil of bergamot.
3	“ “ balm.
3 $\frac{1}{2}$	“ “ neroli.
1	“ “ rosemary.
1	“ “ lavender.
1	“ “ cedrat.
12	drops of “ nutmegs
12	“ “ coriander.
12	“ “ rhodium.
6	“ “ cinnamon.
6	“ “ marjorum.
6	“ “ cloves.
20	“ essence of musk.
6	“ gum camphor.

553. *Good Cologne Water.*

To 2 gallons of alcohol,

- Add $\frac{1}{2}$ ounce of oils of lemon, neroli, and rosemary.
 $3\frac{1}{2}$ drachms of oil of bergamot.
 $\frac{1}{2}$ drachm of oil of cloves.
 1 " tincture of benzoe.
 1 pint of rose water.
 1 " orange-flower water.
 4 ounces of sweet spirits of nitre.
 1 ounce of spirits of camphor.

Filter the whole through sand.

554. *Superior Cologne Water.*

- To 1 gallon of alcohol,
 Add 1 drachm of oils of cloves, lemon, nutmeg, and
 bergamot.
 3 drachms of oil of neroli.
 6 drops of oils of rosemary, lavender, and cassia.
 $\frac{1}{4}$ pint of spirits of nitre.
 $\frac{1}{2}$ " elder flower water.

Filter the whole through white sand.

PERFUMES.

555. *Handkerchief Perfumes (Eau des Alpes.)*

- 1 gallon of alcohol.
 4 ounces of oil of neroli.
 2 " " absynthe.
 6 " essence of Portugal.
 1 ounce each of oils of cedrat, bergamot, and
 lemon.

556. *Eau des Bayadères.*

- $1\frac{1}{2}$ gallons of alcohol.
 4 ounces of oil of bergamot.
 2 " each of oils of lemon and neroli and
 essence of Portugal.

- $\frac{1}{4}$ ounce of balsam of tolu.
 $\frac{1}{4}$ " oil of rosemary.
 10 drops of otto of roses.
- 557. *Laugier's Eau de Paris.***
 1 gallon of alcohol.
 2 ounces each of oils of balm and lemon.
 1 ounce of oil of neroli.
 $\frac{1}{4}$ " " rosemary.
- 558. *Lubin's Caroline Perfume.***
 1 gallon of alcohol.
 2 drachms of oil of balm.
 2 " oils of neroli and bergamot.
 $\frac{1}{2}$ " " lavender and rosemary.
- 559. *Honey-water.***
 1 gallon of alcohol.
 1 ounce of oils of neroli and lemon.
 $\frac{1}{2}$ " " bergamot and cloves.
 10 grains of musk.
 20 " Spanish saffron.
 1 quart each of orange-flower water and rose water.
 1 pint of clarified honey.
- 560. *The Emperor's Special Perfume.***
 $\frac{1}{2}$ gallon of alcohol.
 1 $\frac{1}{2}$ ounce of oil of neroli.
 1 " oils of bergamot and lemon.
 $\frac{1}{2}$ " " thyme and rosemary.
 1 " balsam of tolu.
 1 drachm of otto of roses.
- 561. *Eau de Portugal.***
 1 gallon of alcohol.
 1 pint of rose-water.
 1 ounce of oil of jessamine.
 $\frac{1}{4}$ ounce of essence of ambergris.

- $\frac{1}{4}$ ounce of oil of neroli.
- $\frac{1}{8}$ " " balm.
- $\frac{1}{2}$ " tincture of musk.

562. *Eau de Mousseline.*

- 1 quart of spirits of roses.
- 1 " " jessamine.
- 1 " " violet.
- 1 " " orange flowers.
- 2 ounces of tincture of vanilla.
- 2 " " musk.
- 1 pint of orange-flower water.

563. *Eau des Belles.*

- 1 gallon of alcohol.

Digest for a fortnight the following drugs :

- 2 pounds of rose leaves.
- 1 pound of orange peel.
- 1 " lemon "
- $\frac{1}{4}$ " coriander.
- $\frac{1}{4}$ " Tonka beans.
- $\frac{1}{4}$ " Vanilla "
- 1 " balsam of Peru.

When the whole is filtered, add 1 pint of orange-flower water.

564. *Eau de Millefleurs.*

- 1 gallon of spirits of wine.
- 2 ounces of balsam of tolu.
- 1 " oils of bergamot, neroli, lemon,
thyme, rhodium, lavender, and rosemary.
- 2 ounces of tincture of musk.
- 1 pint of orange-flower water.
- 1 ounce of essence of ambergris.

DENTIFRICES.

565. *Hoofland's Tooth Powder.*
 1 ounce of red saunder's wood powder.
 $\frac{1}{2}$ " " Peruvian bark.
 10 drops each of oils of lemon, bergamot, and
 cloves.
566. *My Tooth Powder, as prepared for my own use.*
 1 ounce of powdered orris root.
 1 " " Peruvian bark.
 1 " " precipitated chalk.
 $\frac{1}{4}$ " " myrrh.
567. *Red Tooth Powder.*
 1 ounce of prepared chalk.
 $\frac{1}{4}$ " carmine.
 $\frac{1}{4}$ " cream of tartar.
568. *Antiseptic Tooth Powder.*
 2 ounces of prepared chalk.
 $\frac{1}{2}$ drachm of chloride of lime.
569. *Charcoal Tooth Powder.*
 1 ounce of charcoal from hard wood.
 $\frac{1}{4}$ " finely powdered myrrh. • •
570. *Gum Wash.*
 1 ounce of tincture of myrrh.
 $\frac{1}{2}$ " " catechu.
 $1\frac{1}{2}$ " spirits of scurvy grass.
571. *Chlorine Tooth Wash.*
 4 ounces of tincture of myrrh.
 $\frac{1}{4}$ " spirits of scurvy grass.
 8 " rose water.
 2 " chlorine water.
 4 " alcohol.
 2 " tincture of ratany.
 $\frac{1}{4}$ " oil of cloves.

572. *Orris Tooth Wash.*

1 pound of orris root is digested for one week in
 $\frac{1}{2}$ gallon of alcohol,
 1 ounce of tincture of myrrh,
 4 ounces of sweet spirits of nitre,
 1 gallon of rosewater,
 1 pound of honey.

573. *Kreosote Tooth Wash.*

1 ounce of tincture of catechu,
 1 " " ratany,
 1 " " myrrh,
 1 quart of kreosote lotion,
 1 gallon of rosewater,
 1 pint of honey.

574. *Myrrh Tooth Paste.*—As prepared by myself in 1830.

2 ounces of powdered myrrh,
 1 ounce of burnt alum,
 1 " cream of tartar,
 4 ounces of cuttle-fish bone,
 2 " drop lake,
 $\frac{1}{2}$ gallon of honey.

575. *Charcoal Opiate.*

1 ounce of powdered myrrh,
 1 " " charcoal,
 1 " " rose leaves,
 20 drops of laudanum,
 1 pint of honey.

576. *Paraguay Roux for Toothache.*

1 ounce of pelletory of Spain,
 1 " elecampane root,
 8 ounces of spirits of wine.

576. *Magnetic Odontica.*

2 leaves of gold,
 2 " silver,

$\frac{1}{2}$ ounce of burnt alum,
 $\frac{1}{2}$ " • prepared chalk,
 $\frac{1}{2}$ " yellow bark,
 1 scruple of pepper,
 10 grains of powdered opium.

ANTIQUE AND MACASSAR OILS.

578. *Antique Oil of Violets.*

8 ounces of olive oil,
 2 " oil cassia,
 4 " " jasmine.

579. *Antique Oil of Millefleurs.*

4 ounces of oil of jasmine,
 4 " " roses,
 4 " " cassia,
 4 " " neroli,
 1 ounce of oil of tuberose,
 1 " vanilla,
 1 " primrose.

580. *Antique Oil for Preventing the Hair from Falling out and Promoting the Growth.*

1 ounce of marrow,
 $\frac{1}{2}$ " white wax,
 2 ounces of olive oil,
 20 drops of oil of cinnamon.

581. *Pot Pouri Antique Oil.*

2 drachms of oil of bergamot,
 $\frac{1}{2}$ drachm " thyme,
 1 ounce of tincture of musk,
 1 drachm " ambergris.

582. *Rowland's Macassar Oil.*

1 gallon of bene-nut oil,

- $\frac{1}{2}$ gallon of olive oil,
- 1 pint of alcohol,
- 3 ounces of oil of bergamot,
- 3 " tincture of musk,
- 2 " essence of Portugal,
- 2 " " roses,

colored with alkanet root.

583. *Pomatum for the Growth of the Hair.*

- 1 ounce of marrow,
- $\frac{1}{2}$ " lemon-juice,
- $\frac{1}{2}$ " tincture of cantharides,
- 10 drops of balsam of Peru,
- 10 " oil of bergamot.

584. *Pomatum for the Complexion.*

- $\frac{1}{2}$ ounce of white wax,
- $\frac{1}{2}$ " spermaceti,
- 1 " oil of sweet almonds,
- 10 drops of balsam of Peru.

585. *The best Hair Antique Oil (Capilantique).*

- 1 ounce of tincture of bark,
- 1 " " catechu,
- $\frac{1}{2}$ " " cantharides,
- $\frac{1}{4}$ " oil of cinnamon,
- 1 pint of old rum.

586. *Cocoa Pomatum for Embellishing the Skin.*

- 1 pound of butter cocoa,
- $\frac{1}{2}$ " white wax,
- $\frac{1}{2}$ " spermaceti,
- 1 drachm of flowers of benzoe,
- 10 drops of otto of roses.

587. *Cosmetic Cream Pomatum.*

- 2 ounces of white wax,
- 2 " spermaceti,
- 4 " oil of sweet almonds,

2 ounces of rosewater,
 $\frac{1}{4}$ " tincture of tolu,
 10 drops of oil of bitter almonds.

588. *Complexion Pomatum.*

1 pound of mutton grease,
 4 ounces of oxyde of bismuth,
 2 " powdered French chalk.

Mix them well together.

589. *Lip Pomatum.*

Melt 4 ounces of white wax,
 2 " ox marrow,
 3 drachms of oil of sweet almonds,
 10 drops of oil of jasmine,

And color with alkanet root.

590. *Pomade Divine.*

12 ounces of ox marrow,
 $\frac{1}{2}$ ounce of flowers benzoe,
 1 drachm of oil of cinnamon,
 1 " " clove,
 1 " " nutmeg.

HAIR DYES.

591. *To dye hair brown.*—Moisten the hair frequently with a solution of potash, and after a week's application the hair turns brown.

592. *To dye hair black.*—Apply a decoction of nutgalls to the hair, and afterwards apply a solution of copperas.

593. *Another black dye.*—To moisten the hair with a solution of sugar lead, and afterwards apply a solution of liver of sulphur.

594. *To dye brown.*—By frequently using a decoction of green walnut leaves, or by the expressed juice of the green butternuts, in alcohol or ether.

595. *Another dye for brown.*—By washing the hair with limewater, afterwards applying the solution of blue vitriol.

 DEPILATORY COMPOUNDS.

596. *To remove the hair from the body.*—Mix quicklime with hepar sulphuris.

597. *Another depilatory.*

3 ounces of hepar sulphur,
 10 “ burnt lime,
 10 “ starch.

598. *Removing hair from hides and skins.*

1 ounce of orpiment,
 2 ounces of burnt lime.

599. *Another depilatory.*—By using frequently fine pumice-stone, and rubbing those parts containing the hair to be removed.

 FUMIGATING ARTICLES.

600. *The Imperial Fumigating Powder.*

1 pound of orris root, coarsely powdered,
 $\frac{1}{2}$ “ rosewood, “ “
 $\frac{1}{2}$ “ cascarilla bark,
 $\frac{1}{8}$ “ cassia,
 1 $\frac{1}{2}$ pounds of blue flowers from the cornfield,
 3 “ rose leaves,
 4 “ lavender flowers,
 6 drachms of oil of thyme,
 3 ounces of oil of bergamot,
 3 “ “ lemon,
 2 “ “ lavender,
 1 drachm of liquid storax.

601. *Fumigating Ingredients for Churches*, especially Catholic churches.

Take juniper berries, bruised,
 Frankincense,
 Gum storax,
 Gum amber,
 Rosewood, $\frac{1}{2}$ pound of each ;
 Cascarella bark,
 Lavender flowers, 4 ounces each ;
 Gum mastic, 3 ounces ;
 Rose leaves,
 Blue flowers, each 2 ounces.

602. *Rose Pastiles for Fumigating Sick-rooms.*

Rose leaves, in powder, 1 pound,
 Gum-arabic, 12 ounces,
 Storax, "
 Olibanum, "
 Saltpetre, 8 ounces,
 Charcoal, 4 pounds,
 Essence of roses, 1 ounce.

Mix the fine powders with 2 ounces of gum tragacanth, dissolved in 1 quart of rosewater.

603. *Red Pastiles.*

Saunder's wood, 5 pounds,
 Rose leaves, "
 Saltpetre, 4 ounces,
 Gum-arabic, "

Make to a mass with gum tragacanth, dissolved in rosewater.

604. *Fumigating Essence.*—A few drops thrown on hot iron refreshes the atmosphere.

Take gum benzoe, 1 pound,
 " storax, "
 Rosewood, "
 Cascarella bark, "

Alcohol, 1 gallon,
 Essence of roses, 1 pound,
 Orange flowers, "
 Vanilla, "
 Amber, "

605. *Preston Salts.*

1 ounce of sal ammonia,
 2 ounces of salts tartar.

The whole mixed together and sublimed in small bottles.

606. *Volatile Salts.*

1 ounce of sal ammonia,
 2 ounces of quicklime.

607. *Vinaigre Rouge.*

3 drachms of cochineal,
 3 " carmine lake,
 6 " alcohol,

1 pound of vinegar perfumed by oil of lavender.

Digest for a fortnight.

608. *Liquid Rouge.*

4 ounces of alcohol,
 2 " water,
 20 grains of carmine,
 20 " ammonia,
 6 " oxalic acid,
 6 " alum.

609. HAIR INVIGORATORS OR RESTORERS.

There are over a hundred different preparations in the market for this purpose. I may mention the most prominent which are offered for sale, such as Lyons' Kathairon, Barry's Tricopherous, Bogle's Hyperion Fluid, Jayne's Hair Tonic; also the Hungarian Balm, Storrs', Barker's, Wood's,

Driscoll's, Phalon's, Haskel's, Mrs. Allen's, and Spalding's Rosemary, &c., &c.; all under various names, yet all depend upon a vegetable oil dissolved in alcohol, with an addition of spirits of soap, and an astringent material to contract the pores of the skin, by a decoction of oak-bark or tincture of catechu, thereby preventing the hair from falling out. Such are the main features of all hair mixtures.

The best recipe is to dissolve 1 ounce of castor oil in 1 pint of 95 per cent. alcohol, and, when fully dissolved, add $\frac{1}{2}$ an ounce of tincture of cantharides. Some add one ounce of tincture of catechu, lemon juice, and tincture of Peruvian bark, and perfume the whole with essential oil of bitter almonds, oil of rosemary, or oil of cinnamon.

610. *Philocome.*

1 ounce of ox marrow,
 $\frac{1}{2}$ " of extract cantharides,
 $\frac{1}{2}$ " of powdered gum arabic.

611. *Dupuytren's Hair Balsam.*

1 ounce of ox marrow,
 3 grains of extract cantharides,
 10 drops of oil of cloves.

612. *Bear's Grease.*

1 ounce of mutton suet,
 2 ounces of spermaceti,
 10 drops of otto of rose.

613. The best hair balsam is prepared from

2 ounces of ox marrow,
 $\frac{1}{4}$ ounce of beeswax,
 10 grains of extract cantharides,
 20 drops of otto of rose,
 5 " of oil of cloves.

CHAPTER IX.

SOLDERS AND SILVERING.

614. *Solder for Metals.*
 2 parts of brass,
 1 " of zinc.
615. *Silver Solder.*
 6 parts of brass,
 5 " of silver,
 2 " of zinc.
616. *Liquid Solder.*
 1 part of chloride zinc,
 2 parts of chloride ammonium (sal ammonia).
617. *Silvering of Brass.*
 2 parts of chloride of silver,
 1 part of sal ammonia,
 $\frac{1}{2}$ " of salt,
 $\frac{1}{2}$ " of glass gall.
618. *Warm Silvering.*
 $\frac{1}{2}$ ounce of chloride of silver,
 2 ounces of salt,
 2 " of sal ammonia,
 2 " of glass gall.
619. *Cold Silvering.*
 $\frac{1}{2}$ ounce of chloride of silver,
 3 ounces of salt,
 3 " of cream of tartar.
620. *Dry Silvering.*
 1 part of chloride of silver,
 3 parts of pearl-ashes,
 1 part of chalk,
 1 " of salt.

CHAPTER X.

VARNISHES.

621. *French Polish.*

$\frac{1}{4}$ ounce of pulverized shellac,
1 pound of alcohol.

When dissolved, add 1 drachm of vermilion, or Dragon's blood.

622. *Shellac Solution for Water Proofing.*—Dissolve the shellac in the heavy oil obtained from distilleries.

623. Or dissolve the shellac in soda-ash, by boiling, and separate the soda by a little oil of vitriol; the shellac is then melted to a thick paste.

624. *Linseed Oil Varnish*, or boiled linseed oil.—To 12 gallons of boiling linseed oil, add, gradually, $\frac{1}{2}$ an ounce of strong nitric acid, which produces, when cold, and left to settle in open vessels, a fine, yellow, clear oil, which dries better than when treated with red lead.

625. *White Mastic Varnish.*

2 ounces of gum sandarac,
2 “ of gum mastic,
 $\frac{1}{2}$ ounce of camphor,

dissolved in $\frac{1}{2}$ a gallon of strong alcohol.

626. *Copal Spirit Varnish.*—1 ounce of finely-powdered gum copal is boiled with 2 ounces of oil of rosemary, and then added to 1 pint of strong alcohol.

627. *White Rosin Varnish* is obtained by dissolving white rosin in alcohol.

628. *Sandarac Varnish for Pasteboard.*

4 ounces of gum sandarac,
1 ounce of powdered glass,

2½ ounces of Venice turpentine,
12 " of alcohol.

Dissolve by heat, and let the glass then settle.

629. *Isochrome Varnish*, for colored engravings and lithographs.

1 quart of spirits of turpentine,
8 ounces of pulverized gum mastic,
4 " of pulverized glass.

Leave it for one month exposed to the sun, frequently shaking it; then add 16 ounces of Venice turpentine.

630. *Varnish for Stamping Linen*.

1 ounce of fine vermilion,
½ " of powdered green vitriol,

are well rubbed up and added to boiled linseed oil, as above described, and the varnish may be spread on a cloth which is nailed on a board; the stamp is touched with this varnish, and pressed upon the linen. The colors, either green by green vermilion, or blue by blue indigo, or Prussian blue, may be employed. The same varnish may be used by diluting it with more linseed oil varnish.

631. *Bleached Shellac Varnish*.

2 ounces of bleached shellac,
2 " of sandarac,
2 " of mastic,
2 " of white rosin,
2 " of camphor.

They are all dissolved in 1 quart of 90 per cent. alcohol.

CHAPTER XI.

INKS.

632. *Best Red Ink.*— $\frac{1}{4}$ ounce of best carmine is dissolved in 10 ounces of aqua ammonia, and 6 ounces of distilled water and $\frac{1}{4}$ ounce of powdered gum-arabic; after shaking the whole mixture, the ink is fit for use in three or four days.

633. *Good Black Ink.*

1 $\frac{1}{2}$ pounds of blue galls,
 1 pound of green vitriol,
 $\frac{1}{2}$ " extract logwood,
 $\frac{1}{2}$ " gum-arabic,

boiled in 5 gallons of water.

634. *Indelible Ink.*

To $\frac{1}{2}$ drachm of nitrate of silver,
 1 " sal soda,
 add 12 grains of tartaric acid,
 15 " orchil,
 16 " sugar,
 1 drachm of gum-arabic.

635. *Blue Ink for Steel Pens.*—Equal parts of yellow prussiate potash and iodide of iron; the precipitate is dissolved in water.

636. *Stephens' Blue Ink.*

8 ounces of Prussian blue, rubbed up with
 1 pound of oil of vitriol to a paste;
 dilute this with water, wash away the excess of acid, and
 add
 1 ounce of oxalic acid,
 1 gallon of water.

637. *Chinese Ink*.—Equal parts of lampblack, boiled for some time in caustic ley, or ivory-black boiled for some time in muriatic acid, frequently washing it afterwards, and then add gum-arabic to make it hard.

638. *Chinese Fluid Ink*.

1 part of the extract of logwood,
8 parts of boiling water,
 $\frac{1}{8}$ part of blue vitriol.

639. *Imperishable Black Stamping Ink*.

1 part of printers' ink,
1 " sal soda,
10 parts of water. Add, when dissolved,
5 " shellac,
 $\frac{1}{2}$ part of sal soda,
 $\frac{1}{2}$ " glue.

640. *Permanent Ink*.—India ink dissolved in muriatic acid.

641. *Permanent Cheap Ink*.—Gluten or starch residue dissolved in pyroligneous or acetic acid or vinegar, and colored by lampblack or indigo paste.

642. *Persian Ink*.

1 ounce of lampblack,
1 " sulphate of iron,
2 ounces of powdered galls,
9 " gum-arabic,
and water sufficient to make it fluid.

643. *Braconnot's Ink*.

10 parts of leather parings,
5 " flower sulphur,
20 " pearl-ashes.

Boil up until dissolved, dry it down again, and dissolve and filter.

644. *Steel Pen Ink*.—To 10 pounds of extract of logwood, dissolved in hot water, add 1 pound of yellow chromate pot-

ash, and sufficient lampblack to blacken it. It requires no gum-arabic.

645. *Copying Ink.*

2 pounds of beer,
4 ounces of galls,
2 " gum-arabic,
3 " green vitriol (calcined),
1 ounce of lampblack,
3 ounces of sugar and honey.

CHAPTER XII.

POISONS FOR DESTROYING INSECTS INFESTING HOUSES.

646. *Phosphorus Paste for Destroying Rats and Mice.*—To 8 ounces of phosphorus, melted in 10 pounds of hot water, add 10 pounds of Indian meal: then rub up by degrees, and add

10 pounds of butter, and
5 “ sugar.

647. *Another Receipt for the Destruction of Field Rats.*—Take equal parts of burnt lime, powdered cicuta, and calcined plaster of Paris, powdered helleborre, and oil of anise: form it into small pills.

648. *For the Destruction of Bedbugs.*—Take pyroligneous acid and dissolve arsenite of potash, and a decoction of oak bark and garlic.

649. *For the Destruction of Moths.*—A mixture of alum, cayenne pepper, oil of camphor, and calcined plaster of Paris.

650. *Another Receipt for Moths.*—Soak blotting-paper in a mixture of oil of camphor and spirits of turpentine, and lay the paper among the clothing or carpets.

651. *For the Destruction of Fleas on Dogs, Horses, and Cattle.*—Take equal parts of

Beef's gall,
Oil of camphor,
“ pennyroyal,
Extract of gentian,
Spirits of wine.

652. *For the Destruction of Cockroaches.*—A mixture of the Persian insect powder and powdered levant wormseed, to throw about where the cockroaches frequent.

653. *Fly Paper for Killing Flies.*—Soak blotting-paper in a solution of sugar of lead, and sweeten it with molasses.

654. *For the Destruction of Musquitoes and Gnats.*—A solution of beef's gall in spirits of camphor and spirits of turpentine.

655. *For Clearing Ants from Pantries.*—Chalk the shelves upon which the provisions are put, so that the ants cannot move about; or apply moistened fly-paper and lay about the pantry; or apply quassia tincture, and soak crumbs of bread with it, and lay it about the pantry.

INDEX.

	PAGE		PAGE
Absinthe.....	95	Animal Sugar.....	14
Absorbents.....	133	Anise Liquor.....	98
Acetate Morphine.....	121	Anisette.....	97
Acetic Acid.....	101	Anodynes.....	184
" " from Verdigris.....	102	Antacids.....	133
" " Sugar of Lead.....	102	Antiseptics.....	135
" Ether.....	6	Anti-Hysterie Mixture.....	136
Acetous Fermentation.....	18	Anti-Spasmotics.....	135
Acid, Pyroligneous.....	102	Antimonial Powder.....	123
" Sulphuric.....	65	Anti-epic Tooth Powder.....	190
Acute Pains.....	130	Antique Oils.....	199
Adulterations of Fermented Liquors.....	109	" " Millefleurs.....	192
Æther for Asthma.....	130	" " Promoting hair growth.....	192
Æthiops Mineral.....	130	" " Pot Pourri.....	192
Agate.....	170	" " Violets.....	192
Agave Wine.....	42	Apple Brandy.....	91
Age and Body Preparation.....	83	" Vinegar.....	107
Ague.....	180, 183	" Wine.....	30
Alcohol contained in Beer.....	23	Aqua Marine.....	169
" " Brown Stout.....	23	Arac.....	88
" " Burgundy.....	82	" Imitation.....	83
" " Champagne.....	82	Ardent Spirits.....	51
" " Claret.....	82	Arnica Flowers.....	129
" " Liquors.....	50	Aromatics.....	136
" " Madeira Wine.....	82	Aromatic Vinegar.....	108
" " Moselle.....	82	" Wine Bitters.....	100
" " Porter.....	23	" Confection.....	118
" " Port Wine.....	82	Artificial Guano.....	164
" " Rhenish.....	82	" Gum Arable.....	165
" " Sherry.....	82	" Precious Stones.....	166
" " Strong Ale.....	23	Ash Tree Sugar.....	15
" " Sugar.....	50	Asphaltum Varnish.....	161
" " Tokay Wine.....	82	Assafetida.....	130
" " Wines & Beers.....	50	Astringents.....	136
Alloys.....	156	Atomic Composition of Sugar.....	20
" for Writing Pens.....	156	Ava Beer.....	24
Almond Emulsion.....	130	Ava, drink of King of Sennar.....	25
Aloes.....	118	Bacher's Tonic Pills.....	147
Alum.....	122	Balm of Gilead.....	147
Alternatives.....	134	Balsam Copaiva.....	130
Amber Ale.....	25	" Honey.....	147
Ambrotype Chemicals.....	159	" Horehound.....	147
" Apparatus.....	159	" Liquorice.....	147
" Colors.....	162	" Peru.....	130
Amethyst.....	170	" Tolu.....	130
Ammonia Gum.....	130	Barclay's Anti-Bilious Pills.....	147
Angelica Cordial.....	99		

	PAGE		PAGE
Bark, Peruvian	180	Brazil-wood for Coloring	48
Barley	87	British Oil	150
Basilicon Salve	118	Bromo-iodide Silver	161
Bateman's Drops	148	Buchu Leaves	180
Bate's Anodyne Balsam	148	Burns	187
Bear's Grease	198	Calamus	29
Bedbug Destroyer	205	Calomel	119, 180
Beer, Ays.	24	Camphor	117, 180
" Bavarian	27	" Julep	149
" Beverages	27	Canary Wine	44
" Generator	22	Cancer, <i>see</i> Hemlock Powder	180
" Ginger	27	Cane Sugar	14
" Heading	29	Capilantique	193
" Lager	28	Capsicum in Beer	29
" Millet	23	Caraway Seed	129
" Milk	24	Carbonate of Ammonia	116
" Murwa	28	" Magnesia	121
" Root	28	" Soda	126
" Preparation of	21	Carbonic Acid Gas	183
" Spruce	28	Cardamom Seed	180
Berzelius' Paste for Labels	174	Cardinal	101
Best Red Ink	202	Carminatives	138
Birch Wine	41	Carrot Wine	41
Bisulphide of Lime	17	Castile Soap	126
Bitters	100	Castor Oil	121, 180
Black Currant Wine	40	Cascarilla	180
" Ink	202	Catechu	180
Blacking for Boots	171	Catalysis, Berzelius's	101
" Harness	171	Cava Beer	24
Bland's Female Pills	148	Celery Cordial	99
Bleaching Feathers	171	Cement, cistern	175
" Shellac	171	" diamond	172
" Sponge	171	" hydraulic	75
" Straw	171	" mastic	175
Bleeding draught for Uterine	187	" soluble glass	174
Blister Plaster	118	" soluble, how to prepare	174
Blue Ink	202	" steam-resisting	178
" Ointment	124	" transparent	178
" Pill	122	" for fastening iron in stone	174
" Tourmaline	69	" " glass on metal	174
" Vitriol	118	" " metal on wood	174
Boils	187	" " bottles	175
Borax	126	" " furniture	175
Bordeaux Wine	45	" " glass and porcelain	174
Bouza	23	" " glass and putty	178
Bouquet of Wine	88	" " iron	173
Bourbon Whisky	87	" " knives and forks	178
Bowel Complaint	148	" " paper labels	174
Braconnot's Ink	203	" " Stephenson's steam-pipe	178
Brandy, Apple	91	" " stone	173
" Banana	98	" " teeth	175
" Blackberry	91	Chalk	180
" Cherry	91	" Mixture	148
" Cider	91	Chamberlin's Restorative Drops	149
" Cinnamon	92	Chamomile Flowers	181
" Clove	92	" Powder	123, 193
" Ginger	92	Champagne	46
" Orange	92	" from gooseberries	47
" Pear	98	" " cider	47
" Pine Apple	98	" Mixture	112
" Plum	92	" Powder	112
" Raspberry	91	Chapped Han s	188
" Rhubowitz	92	Characteristics of Beer	29, 30
" Zwetschen	92		

	PAGE		PAGE
Cramps	140	English Polishing Powder.....	177
Cranberry Wine.....	40	" Champagne.....	112
Cream Balls.....	185	Epsom Salts.....	130
" Soap.....	184	Ergot of Rye.....	125
" of Tartar.....	180	Essence of Life.....	150
Cretaeous Powder with Opium..	130	" Cognac.....	87
Crimson colored Fire.....	181	Examples of Mixture of Spirits and	
Croton Oil.....	122	Water.....	74
Cubeba, ground.....	180	Expectorants.....	142
Curaçoa Cordial.....	96	Extract of Conium.....	118
Current Wine.....	89	" Hyoscyamus.....	119
" (Black) Wine.....	40	" Milk.....	150
" Champagne.....	118	" Opium.....	119
Cutaneous Eruptions, <i>see</i> Antimo-		" Malt.....	23
nial Powder.....	130	" Liquors.....	23
		" Small Beer.....	23
Dalby's Carminative.....	150	" Punch.....	94
Damson Wine.....	40	" Bishop.....	95
Date Sugar.....	18	" Glow Wine.....	95
Decreasing Fermentation.....	59	" Grape Juice.....	87
Delamotte's Golden Drops.....	150	Fainting Fits, <i>see</i> Spirits Sal Volatile	130
Dentifrices.....	190	Family Soap.....	184
Depilatories.....	195	" Yeast.....	68
Depilatory Compounds.....	195	Ferment.....	18
Destruction of Bedbugs.....	205	Fermented Liquors.....	20
" " Cockroaches.....	206	Fermentation decreasing.....	59
" " Flies.....	206	" rising.....	59
" " Mosquitoes.....	206	" upper and lower.....	26
" " Rats.....	206	" Vegetable Products.....	62
Detergent Soap.....	185	" Wort.....	59
Diabetes.....	180	Fevers, <i>see</i> Spirits of Nitre.....	130
Diachylon Plaster.....	118	Fever and Ague Kennedies.....	151
Diarrhoea.....	141	" " Plaster.....	151
Diastase.....	21	" Draught.....	152
Diseases.....	114	" Pills.....	151
Distillation.....	58	Field Rats, for destruction of.....	205
Distilled Vinegar.....	115	Fine Red Sealing Wax.....	172
Ditchett's Spanish Pile Liniment..	150	Fire, Green.....	180
Doses.....	114	" dark Green, cheap.....	180
Dovers Powder.....	123	" Sky Blue.....	180
Draught for Uterine Bleeding.....	187	Fireworks, with two bases.....	180
Dropsy.....	130	Fits.....	142
Dry Slivering.....	199	Flatulence, <i>see</i> Compound Tincture	
Dry Wines.....	82	of Gentian.....	130
Dupuytren's Hair Balsam.....	193	Flavoring for Brandy.....	86
Dyes, Hair.....	194	" " Gin.....	90
Dysentery.....	141	" " Ginger Wine.....	42
		" " Port.....	41
Eau des Alpes.....	187	Fleas on Animals.....	205
" " Belles.....	189	Flip.....	111
" des Bayadères.....	187	Flooding, <i>see</i> Alum.....	130
" de Minnefleurs.....	189	" " Infusion of Roses.....	130
" de Mousseline.....	189	Fluor Albus.....	152
" de Portugal.....	188	Fluid Magnesia.....	152
Egg Punch.....	112	Fly Paper.....	206
Elastic Platina.....	156	Fork Cement.....	178
Elderberry Sugar.....	18	Formula for Reduction of Spirits by	
Electuary Lentive.....	130	Water.....	75
Elixir Vita.....	98	Fothergill's Pills.....	158
" of Vitriol.....	130	Foxglove Tincture.....	157
Embrocations.....	141	Freckles.....	142
Emetics.....	142	French Polishing Powder.....	172
Emerald.....	167	Fruit Sugar.....	14
Emperor's Perfume.....	188		

	PAGE		PAGE
Fruit Syrups.....	84	Hiccough.....	148
Fumigating articles.....	195	Hiera Ptera.....	180
Fumigating Ingred'nts for Churches.....	196	Hill's Essence of Bandana.....	153
Fumigating Essence.....	196	Hippocras.....	110
Furniture Cement.....	175	Hoffmann's Anodyne.....	180
" Polish.....	178	Hoofland's Tooth Powder.....	196
Fusel Oil.....	58	Holland Gin.....	89
" destroyed by Oil of Vitriol.....	65	Honey Water.....	183
		" Wine.....	43
Gall's complete Still.....	57	Hooper's Female Pills.....	153
Guerlin's Eau de Cologne.....	186	Hooping Cough.....	148
Gentian Root.....	119	" " Tea.....	154
" Tincture.....	180	Hops.....	93
Gin, Clearing of.....	89	House Remedies.....	147
" Flavoring.....	89	Hungarian Waters.....	153
" how to imitate.....	89	Hydraulic Cement.....	175
" " manufactured.....	89	Hydrobromic Acid.....	161
" Holland.....	89	Hydrochloric.....	116
" London.....	89	Hydrocyanic.....	116
" " Cordial.....	89	Hydrometer.....	80
" " Milky, how to clear.....	89	" and Thermometer... 81, 83	
Ginger Beer.....	27	Hydrophobia.....	153
" Brandy.....	92	Hygeine.....	114
" Cordial.....	99	Hysterics.....	180
" Powder.....	180		
Gleet, <i>see</i> Balsam Copaiva.....	180	Iceland Moss.....	109
" " Cubeba.....	180	Imitation Gold.....	156
" " Venice Turpentine.....	180	" Silver.....	156
Gleet and Whites, <i>see</i> Tincture of		" Precious Stones.....	156
Guajac.....	180	" Guano.....	156
Glow Wine.....	111	" " Gum Arabic.....	156
Gluten.....	14	Indigestion.....	180
Glycer-rhine Soap.....	183	Inflammatory Fever.....	180
Gna's.....	206	Inks.....	203
Gooffrey's Cordial.....	152	" Braconnot's.....	203
Gold, imitation of.....	156	" " best Red.....	203
" new.....	156	" " good Black.....	203
Good Yeast.....	62	" " imperishable Stamping.....	203
" Black Ink.....	202	" " Indelible.....	203
" Paste.....	174	Iodide Potassium.....	120
Goulard's Extract.....	120	Iodine Tincture.....	180
" Lotion.....	152	Iodized Collodion.....	161
Gout, <i>see</i> Ginger Powder.....	180	Ipecacuanha Powder.....	180
Gouty Pains.....	141	Irish Moss.....	109
Grain Stone.....	22	" Whisky.....	87
Grape Sugar.....	14	Iron Cement.....	178
Gravel, <i>see</i> Spirits of Turpentine.....	180	Irritation in Bladder.....	180
Green Sickness, <i>see</i> Tincture Myrrh.....	180	Isochrome Varnish.....	201
Grog.....	111	Ivory Black.....	64
Guajac Gum.....	180		
Gum Ammoniac.....	180	Jalap Powder.....	180
" Arabic, powdered.....	122	Jamaica Rum.....	90
" Syrup.....	84	James's Powder.....	123
" Wash.....	190	Jesuits' Drops.....	154
" Tree Manna.....	15	Julep, Mint.....	110
Gun Cotton preparation.....	161	Juniper Wine.....	
Guy's Antiseimtic Powder.....	128		
		Keyser Pills.....	154
Hair Balsam.....	198	Kimmel Liquor.....	93
Handkerchief Perfume.....	187	Kinds of Charcoal for Rectifying... 66	
Hannay's Lotion.....	153	Kirschwasser.....	98
Hartshorn, Spirits of.....	180	Knee-bend Beverage.....	111
Heartburn.....	143	Kreosote Tooth Wash.....	191
Heinlock Powder.....	180	Koumiss.....	24

	PAGE		PAGE
Lactic Fermentation.....	13	Medicines in daily practice.....	115
Lady Webster's Dinner Pills.....	154	Medoc Wine.....	43
Lager Beer.....	23	Melon Sugar.....	17
" " consumption.....	23	Mercurial Pill.....	123, 130
Langier's Eau de Paris.....	188	Mercury with Chalk.....	119, 180
Latest improvem't in Quick Vinegar	106	Metalurgy.....	156
Lavender Compound.....	130	Metals.....	156
Lecote's Tallow Soap.....	158	Metallic Pencils for Writing.....	158
Ledum Palustre.....	109	Metamorphose of Fermentation.....	101
Lemonade Gazeuse.....	28	Milk Beer.....	23
Lemon Syrup.....	84	" Sugar.....	14
" Wine.....	42	Millet Beer.....	23
Light Blue Fire.....	182	Minderer Spirit.....	154
Linen Gloss.....	185	Mint Julep.....	110
Linseed Oil.....	121	Mixture for keeping Ess. Oils.....	69
" Varnish.....	200	" " rectifying.....	64
Lip Salve.....	194	Molasses.....	17
Liquid Ammonia.....	120	Monongahela Whisky.....	84, 87
" Rouge.....	197	Morrison's Hygeinic Pills.....	154
" Solder.....	199	Moths.....	205
Liquor, Peppermint.....	93	Mulberry Wine.....	40
" Pota-sa Arsenitis.....	100	Muriate of Ammonia.....	116
" Wormwood.....	93	Muriatic Acid.....	180
Liquorice Extract.....	19	Murwa Beer.....	23
" Sugar.....	14	Muscat Wine.....	44
Liver Complaint.....	180	Muscovada Sugar.....	17
Lobelia inflata.....	150	Musk.....	180
London Cordial Gin.....	89	Myrrh.....	180
Long-life Co. dial.....	98	" Tooth Paste.....	191
Lotions, external.....	130	My Tooth Powder.....	190
Lowness of Spirits.....	130		
Low's Brown Windsor Soap.....	184	Nectar Cordial.....	99
Lubin's Caroline Perfume.....	188	Negus.....	111
		Nervous Headache.....	180
Macassar Oil.....	192	" Cordial.....	154
Madeira Wine.....	43	Neutralizing the Sharp Taste.....	88
Magnesia.....	187	New England Rum.....	90
Magnetic Odontica.....	191	Nitrate Pota-sa.....	124
Maize Sugar.....	15	" Silver.....	160
Malaga Wine.....	44	Nitre, Sweet Spirits.....	180
Malt.....	21	Nitric Acid.....	180
" Barley.....	21	Nostrums.....	147
" Corn.....	21	Noyeau.....	99
" Oats.....	21		
" Rye.....	21	Obstinate Costiveness.....	180
" Wheat.....	21	Oenanthic Ether.....	83
Manna.....	130	Oil, Cognac.....	86
" Mount Lebanon.....	19	" Lin-seed.....	121
" Persian.....	19	" Olive.....	121
" Sugar.....	14	" Peppermint.....	121
Mannite.....	18	" Turpentine.....	122
Maple Sugar.....	14	Opiate Confection.....	180
" Wine.....	41	Opium.....	188
Maraschino Cordial.....	96	Opodeldoc.....	185
Mare's Milk.....	24	Orange Brandy.....	92
Mashing Operation.....	58	" colored Fire.....	182
Mastic Varnish.....	200	" Elixir.....	98
Maeria Medica, table of.....	130	Orcin Manna.....	19
Mathew's Injection for Fistula in		Orgat.....	99
Ano.....	154	Orite.....	156
Mead Wine.....	43	Orris Tooth Wash.....	191
Measles.....	144	Oyster Shells, prepared.....	180
Medical Cases.....	188		
" " treatment of.....	114	Paint Cleaner.....	177

PAGE		PAGE	
Pale Ale.....	25	Raisin Wine.....	29
Palm Wine.....	41	Ragcakes used in Beer.....	29
Palpitation of the Heart.....	186	Raspberry Brandy.....	91
Pargnny Roux.....	191	" Cordial.....	97
Paragoric.....	128.	" Syrup.....	84
Parfait d'Amour.....	97	" Vinegar.....	108
Patent Soap Liquid.....	184	" Wine.....	40
Payen's India Rubber Cement.....	174	Recent Cold. <i>see</i> Spermaceti.....	130
Peach Brandy.....	91	" Cough, <i>see</i> Dovers Powder.....	130
Pear.....	93	Rectified Spirits of Wine.....	127
Pectorals.....	144	Rectifying Apparatus.....	65, 68
Peppermint Essence.....	130	" by Sulphuric Acid.....	65
" Liquor.....	98	" Process.....	64
Perfumes.....	187	" with Sand.....	67
Persian Ink.....	208	Reducing Tables of Alcohol.....	72
" Manna.....	19	" " various	
Peters' Pills.....	155	per-centage.....	73
Piflocoma.....	193	Red colored Fire.....	179
Pile Ointment.....	155	" Pastiles for sick-rooms.....	196
Pills for Bleeding.....	187	" Tooth Powder.....	190
Pimples.....	144	Remedies.....	114
Pine Apple Brandy.....	92	" House.....	147
Platina.....	174	Removing Hair from the Body.....	195
Pleurisy.....	144	" " Hides.....	195
Plum Brandy.....	92	Restorative for Scrofula and Scurvy.....	155
Plummer's Pills.....	122	Rhatany.....	181
Poisons for destroying Insects.....	205	Rheumatism.....	141, 155
Polytechny.....	156	" and Gout, <i>see</i> Colombo.....	130
Pomade Divine.....	194	Rhine Wine.....	46
Pomatum for Complexion.....	193	Rhubarb.....	130
" " Hair.....	198	" Champagne.....	118
Pope, a Beverage.....	110	Rice Vinegar.....	108
Port Wine.....	41	Ringworm.....	145
Potato Wine.....	41	Rising Fermentation.....	59
Powdered Opium.....	124	Roche's Embrocation.....	155
" Rhubarb.....	124	Rochelle Brandy.....	87
" Squills.....	125	" Salt.....	126, 130
Prepared Chalk.....	123	Roman Punch.....	98
Preparation for Clearing Liquors.....	83	Root, Anti-Syphilitic.....	155
" of Wines.....	32	" Beer.....	28
Proof Spirit.....	70	Roses, Infusion.....	130
Pumice Soap.....	185	Rose Cordial.....	99
Punch, à la Glace.....	112	" colored Fire.....	193
" cold.....	111	" Pastiles, for sick-rooms.....	196
" Extract.....	94	Rosin.....	118
" hot.....	112	Rowland's Maccassar Oil.....	192
" Royal.....	112	Royal Punch.....	112
Putrefaction.....	63	Ruby.....	167
Pyrotechnics.....	179	Russian Drink.....	24
Pyroligneous Acid.....	102	Rye Whisky.....	87
Quantity of Ceanthio Ether con- tained in Wine.....	33	Safe Red Fire.....	179
Quassia.....	109	Saffron.....	130
" used in Beer.....	29	Sai Ammonia.....	116
Quick Vinegar.....	101	Salts, Cheltenham.....	130
" Lime.....	117	" Epsom.....	130
Quince.....	88	" Glauber's.....	130
Quinine.....	125	" Tartar.....	130
" Pills.....	152	" Tasteless.....	130
Quincy (Sore Throat).....	155	Salt used in Beer.....	29
Racahont des Arabes.....	155	Saltpetre.....	124
Railroad Liquor.....	98	Sandarac Varnish.....	206
		Sapphire.....	167
		Sarsaparilla.....	129

PAGE		PAGE	
180	Sarsaparilla Powder	17	Sugar of Chestnuts
187	Scalds	17	" preparation of
180	Scammony	84	" Syrup
125	" Powder	19	" Utah
27	Scotch Ale	43	" Wines
145	Scurvy	16	" from Flax
172	Sealing-wax, Black	16	" " Iceland Moss
173	" for Bottles	16	" " Irish
173	" Red	16	" " Linen Bags
173	" fine	16	" " Paper
145	Sea-sickness	16	" " Raw Cotton
162	Sel d'Or preparation	16	" " Sea-weeds
180	Senna	16	" " Woody Fibre
126	" Leaves	14	" Beet
200	Shellac Solution	14	" Liquorice
45	Sherry Wine	14	" Palm
18	Shower of Snow Sugar	14	" Potato
134	Silk Soap	129, 180	Sugar of Lead
199	Silver Solder	118	Sulphate of Copper
199	Silvering of Brass	119	" Iron
199	" Dry	121	" Magnesia
199	" Warm	180	" Quinine
190, 185	Soap Liniment	123	" Zinc
185	" Transparent	180	Sulphur, Flowers of
180	Soda	190	" Milk
199	Solder for Metals	128	" Ointment
199	Soldering and Silverings	127	" Sublimed
124, 180	Soluble Tartar	29, 116, 119	Sulphuric Acid
120	Solution of Sugar of Lead	65	" " destroys Fusel Oil
155	Sore Throat	126	Sweet Spirits of Nitre
15	Sorghum Sugar	82	Sweetness of Wines
46	Sparkling Wines	70	Sykes' Hydrometer
41	" Maple Wine	71	" " Table of
180	Spasms, Acute, see Tinct. Opium	183	Symptoms
180	" " Henbane	180	Syrup of White Poppies
54	Specific Gravity of Alcohol	180	" Buckthorn
102	" " Vinegar	180	" Ginger
180	Spermaceti	49, 73	Table of per-centage of Alcohol
117	" Ointment	50	" " Beers
155	Spider Webbing	50	" " Liquors
120	Spirits, Hartshorn	49, 73	" " Wines
180	" Nitre	84	" Cordial Wines
180	" Sal Volatile	84	" Dry
122	" Turpentine	84	" Greasy
145	Spitting Blood	84	" Red
28	Spruce Beer	85	" White
180	Squill Oxyinel	180	" Materia Medica
180	" Powder	71	" Sykes' Hydrometer
117	Starch	19	Tarfa Tree
185	" Polish	117, 180	Tartar Emetic
15	" Preparation	82	" in wine casks
15	" Sugar	116	Tartaric Acid
203	Steel Pen Ink	38	" " in juice of Grapes
202	Stephens' Blue Ink	124	Tartrate of Potassa
145	Stomachos	105	Temperature of Vinegar Room
93	Stomachic Bitters	165	Testing Guano
29	Stramonium Seed	180	Tin Powder
27	Stras-burg Ale	180	Tincture of Aloes
166	Strass	180	" Arnica Flowers
108	Strawberry Vinegar	180	" Assafoetida
40	" Wine	130	" Bark
115	Strong Acetic Acid	180	" Benzoin
17	Sugar Juice in Sugar Cane	180	" Cantharides
48	" Colorings		

	PAGE		PAGE
Tincture of Cascarella	130	Weight of good Guano	163
“ Catechu	130	Whisky	87
“ Colombo	130	“ Barley	87, 88
“ Foxglove	127	“ Bourbon	87
“ Gentian Compound	130	“ Common	88
“ Guajac Gum	130	“ Irish	87
“ “ Volatile	130	“ Rye	87
“ Hartshorn	130	“ Scotch	87, 88
“ Hentane	127, 130	“ Wheat	87, 88
“ Hops	130	White Metallic Composition	157
“ Iron	127	“ Metal, instead of Tin	157
“ Jalap	130	“ “ for casting and rolling	158
“ Myrrh	130	Wine, Agaric	42
“ Opium	128, 130	“ Apple	30
Tobacco Leaves	29	“ Beverages	33
Tokay Wine	45	“ Bouquet of	33
Toning or Coloring Bath	162	“ Cherry	33
Tooth Cement	175	“ Colchicum	130
Treatment	138	“ Colorings	43
“ in Medical cases	114	“ Columbia	42
Turbid or Cloudy Liquors	88	“ Currant	39
Turpentine, Venice	130	“ Dry	33
Turquoise	170	“ Gooseberry	39
Valerian Powder	130	“ Ginger	42
Varnish, Bleached Shellac	201	“ Ipecacuanha	130
“ Copal Spirit	200	“ Lemon	42
“ for Stamping Linen	201	“ Mixture	34
“ Isochrome	201	“ Pear	33
“ Linseed Oil	200	“ Quince	38
“ Mastic	200	“ Raisin	39
“ Sandarac	200	“ Sugar	42
Vegetable Albumen	14	Wines, Consumption of	36
Vinegar	101	“ Fining of	85, 86
“ Distilled	115	“ Production of	86
“ Quick	101	Yeast of Beer	61
Vinous Fermentation	13	“ Beer	62
Vitriol, Blue	179	“ Brewers'	62
“ Elixir	130	“ Composition	61
“ Oil	63	“ Family	63
Warm Silvering	199	“ Good	62
Water-proofing Solution	200	Zellthold, or Beer Generator	22