

ELECTRONIC COUNTING CIRCUITS

J. B. DANCE, M.Sc., B.Sc.

LONDON ILIFFE BOOKS LTD
NEW YORK AMERICAN ELSEVIER
PUBLISHING COMPANY INC.

© J. B. Dance, 1967

First published in 1967 by Iliffe Books Ltd.,
Dorset House Stamford Street, London S.E.1
Published in the U.S.A. by
American Elsevier Publishing Company Inc.,
52 Vanderbilt Avenue, New York, N.Y. 10017
Library of Congress Catalog Card Number 67-13048
Franklin Press, Budapest

CONTENTS

		<i>Preface</i>	7
		<i>Acknowledgements</i>	9
Chapter	1	Introduction	11
	2	Electro-magnetic counters	32
	3	Single cathode gas filled counting tubes and their circuits	40
	4	Multi-electrode gas filled counting tubes and their circuits	67
	5	EIT decade counting circuits	154
	6	Beam switching tubes	181
	7	Valve scaling circuits	216
	8	Solid state scaling circuits	232
	9	Ratemeter circuits	276
	10	Readout	295
	11	Nuclear counting and instrumentation	310
	12	Further applications of counting circuits	341
Appendix		Valve equivalents and near equivalents	375
		<i>Index</i>	379

PREFACE

In spite of the importance of counting circuitry in modern electronic equipment, it is understood that no book has appeared in the English language specifically on this subject since W. B. Lewis's 'Electrical Counting' was published by Cambridge University Press in 1942. At that time very few counting techniques were known. A paper-backed book entitled 'Elektronische Zähl-schaltungen' by K. Apel was published in German by Franckh'sche Verlagshandlung, Stuttgart, in 1961. Although numerous papers have been published on counting circuitry, a search of the literature consumes a great deal of time even if the required publications do happen to be available when they are needed. In addition, some papers are not easily read by those who do not already have a reasonable knowledge of the subject. This book has been written to meet the needs of students, designers, servicemen and users of electronic counting equipment who require the theory of operation and practical information on all of the normal types of counting circuit in one volume.

It is assumed that readers have a reasonable knowledge of basic physics and of the operating principles of thermionic valves and transistors. Where other devices (such as trigger tubes and tunnel diodes) are employed in counting circuits, the basic principles of operation of the devices are discussed.

Many of the circuits reproduced in this book are those recommended by the manufacturers of the tubes or semiconductors employed. This should ensure that they are some of the best and most reliable circuits available, since the component manufacturers normally know far more of the advantages and limitations of their own products than anyone else and can make due allowance for these limitations in the circuits they design. A practical approach has been adopted throughout the book and component values are given in most circuits. A fairly large number of references have been included to assist those requiring further information on any particular topic.

The circuits have been classified according to the type of component employed for the counting operation rather than the particular type of circuit (ring, binary, binary coded decade, etc.) used, since it is felt that this approach is a more practical one. Each chapter has been written so that it is essentially complete in itself and may be understood by anyone who is reasonably familiar with the material of the first chapter; this has necessitated a small amount of repetition, but should assist readers who require information on one specific type of circuit. Some of the older types of circuit which are now seldom used have been included to make the book as comprehensive as possible. As in most other fields of electronics, there is a general trend for solid state devices to replace the larger circuits employing vacuum or gas filled tubes and this has inevitably resulted in some types of decade tube becoming obsolete.

The basic principles of counting are discussed in Chapter 1. The various types of counting circuit are described in detail in Chapters 2 to 9 inclusive. Readout devices not covered in the earlier chapters are discussed in Chapter 10. A short survey of nuclear radiation detectors (often referred to as 'counters') is given in Chapter 11 together with some details of the circuits with which they are normally used. An attempt has been made in Chapter 12 to outline some of the more important uses of counting circuits in industry and in instrumentation (other than in computers) and to provide general information on some particular types of application.

Alcester, 1967

J.B.D.



ACKNOWLEDGEMENTS

The author wishes to acknowledge the assistance given to him by the following companies and persons who have provided information or photographs and have permitted the reproduction of their circuits in this book.

Beckman Instruments Ltd.
Bell Telephone Laboratories, U.S.A.
Bendix Electronics Ltd.
Britec Ltd.
Brush Clevite Co. Ltd.
Burndept Electronics Ltd.
Burroughs Corporation, U.S.A.
B. & F. Carter & Co. Ltd.,
Centrex Publishing Co., Holland.
Cerberus AG, Switzerland.
Dr. G. B. B. Chaplin (Plessey Ltd.)
Compagnie Général De Télégraphie Sans Fil
(C.S.F.), France.
Coulter Electronics Ltd.
Counting Instruments Ltd.
Digital Measurements Ltd.
Ecko Electronics Ltd.
Electronic Associates Ltd.
The Editor, *Electronic Engineering*.
The Editor, *Electronics* (U.S.A.).
Elesta AG, Switzerland.
Elliott Brothers Ltd.
Ericsson Telephones Ltd.
Evans Electro Selenium Ltd.
S.G.S. Fairchild Ltd.
Ferranti Ltd.
Dr. E. Franklin (A.E.R.E., Harwell).
General Electric Co., U.S.A.
Gloster Equipment Ltd.
The Editor, *Helvetica Physika Acta*, Switzerland.
Hewlett-Packard Ltd.
Hivac Ltd.
The Institute of Electrical and Electronic Engineers,
U.S.A.

The Institution of Electrical Engineers.
I.B.M. United Kingdom Ltd.
K.G.M. Electronics Ltd.
Labgear Ltd.
Marconi Instruments Ltd.
Motorola Semiconductor Products Inc., U.S.A.
Mullard Ltd.
Mullard Equipment Ltd.
Pacific Semiconductors Inc., U.S.A.
Philco International Ltd.
Philips Gloeilampenfabrieken, Holland.
Racal Instruments Ltd.
The Editor, *The Radio and Electronic Engineer*.
Raytheon Co., U.S.A.
Semiconductors Ltd.
Société des Compteurs de Genève (Sodeco), Switzerland.
The Solartron Electronic Group.
Solid State Products Inc., U.S.A.
Sprague Electric Co., U.S.A.
Standard Telephones & Cables Ltd.
Stonebridge Electrical Co. Ltd.
Sylvania Electric Products Inc., U.S.A.
Telefunken G.m.b.H., Germany.
Texas Instruments Ltd.
Mr. T. D. Towers (Newmarket Transistors Ltd.)
Transistron Electronic Ltd.
Tung-Sol Inc., U.S.A.
Twentieth Century Electronics Ltd.
The United Kingdom Atomic Energy Authority,
Harwell.
Veeder-Root Ltd.
Walmore Electronics Ltd.



Introduction

Enormous advances have been made in all types of electronic instrumentation during the last twenty years, but this progress is most apparent in the design of modern electronic counting equipment. Much of the earlier work on counting circuitry was stimulated by the very great post war developments in nuclear physics and in the applications of radio-isotopes in research, industry and medicine. For these purposes high speed counting equipment is essential. Counting equipment is, however, very useful for many purposes other than that of counting nuclear particles. It is an essential part of most automation processes in modern factories, enables high speed computers to be constructed and when used in laboratory equipment allows many kinds of measurements to be made quickly. The answer is often presented in the form of actual digits to many significant figures. Electronic methods of counting are gradually replacing many of the mechanical systems used in industry, since they are very much faster, more versatile and generally more reliable.

1.1 BASIC COUNTING METHODS

There are two basic types of measurable quantity. The first type consists of a whole number of discrete individual events, for example the number of articles coming off a production line. If each event is converted into an electrical impulse (e.g. by means of a photocell), the number of pulses and hence the exact number of articles can be counted electronically. If the equipment is working correctly, there should be no error whatsoever. The second type of measurable quantity may vary continuously

and need not have an integral value; examples of such quantities are time, the rate of flow of a liquid through a pipe and the electrical potential between two points. Such a quantity can normally be converted into electrical impulses, the number of impulses or the frequency of the impulses being a measure of the quantity concerned. The impulses can be counted electronically, but the accuracy of the overall measurement is obviously limited by the fact that a fraction of a pulse cannot be generated. Thus counting equipment can, in principle, be used to make almost any kind of measurement and may be designed to provide outputs which can be used to control even the most complicated machinery.

One of the first methods by which electrical pulses were counted involved the use of an electromagnetic register. This type of register consists of a relay mechanism and a drum on which the digits 0 to 9 are painted. Only one of these digits is visible through the viewing aperture at any time. When a suitable pulse of current is passed through the magnetising coil, an armature is attracted and the drum is moved so that the succeeding digit is indicated. When the drum returns from 9 to 0 at the tenth pulse, a mechanical linkage may be used to cause a second similar drum to move so that the latter indicates the digit 1. The two drums together indicate the number 10. This arrangement may be used to count up to 99 pulses, but more drums may be used if necessary so that larger numbers may be indicated. The type of display from an electromagnetic register is similar to that from the mileage indicator of a car. The registers are described in detail in Chapter 2.

ELECTRONIC COUNTING CIRCUITS

The maximum speed at which an ordinary electro-magnetic register can operate is about 10 to 25 pulses per second. This is much too slow for many applications. Valve counting circuits were therefore designed which would divide or scale down the number of incoming pulses by a suitable factor. The output pulse frequency from the valve circuit could be counted by an electro-magnetic register. If the scaling factor is ten, the valve circuit provides one output pulse for each ten input pulses applied to it. Such valve circuits became known as scalars because they scale down the input pulse rate. The valve scaling circuit and the succeeding electro-magnetic register were often placed in the same unit, the whole of which became known as a scaler. Nowadays any piece of counting equipment which counts each individual pulse is known as a scaler.

A circuit which provides one output pulse for each ten input pulses applied to it is known as a decade counting circuit, or merely as a decade. Valve decades were the first type to be designed, but are relatively large and require a considerable amount of power. Various special tubes with many electrodes have been designed which enable counting circuits to be constructed in a much smaller volume, only one of these special tubes being required in each decade circuit; such tubes are known as decade counting tubes or decade tubes. The three main types of decade tube are the gas filled cold cathode tubes (Chapter 4), the EIT cathode ray tube (Chapter 5) and beam switching tubes (Chapter 6). Most types of decade tube first came into production about 1950. Modern scalars for very high speed operation often employ semiconductor counting circuits.

1.1.1 Ratemeters

Scalars count each individual pulse separately. Another type of circuit amplifies, shapes and smooths out the incoming pulses and uses the resulting current to deflect a meter. The meter indicates the rate of arrival of the input pulses with a reasonable degree of accuracy. Instruments using this principle are known as ratemeters. They have the advantage that they are

rather simpler to use than scalars, since they give direct readings and no time measurements need be made.

1.1.2 Pulses

The units which are counted by electronic circuits are electrical pulses. An electrical pulse consists of a transient change in the potential difference between two points in a circuit or a transient change in the current flowing at a certain point in a circuit. The duration of the pulse may vary from a very small fraction of a microsecond to many seconds, after which the voltage or current returns to its former quiescent value. If the potential at a point in a circuit becomes more positive for the duration of the pulse, the latter is said to be a positive going pulse at the point concerned. At another point in the circuit, the pulse caused by the same initial event may be negative going. An ordinary valve amplifier in a common cathode circuit or a transistor amplifier in a common emitter circuit will invert a pulse; that is, a negative going pulse applied to the input of the amplifier will be converted into a positive going pulse at the output and, of course, vice-versa.

The simplest type of pulse is formed when the voltage (or current) at a certain point in the circuit is switched from its quiescent value to another value and remains constant at this new value until the end of the pulse, when it is switched back to its quiescent value. If the switching process could be carried out instantaneously, the pulse would be a theoretically 'ideal' pulse in which the graph of the voltage (or current) during the pulse plotted against time would be rectangular in form. Such pulses are known as rectangular or square pulses. The difference between the two voltages is the amplitude of the pulse; the only other variable in the case of a rectangular pulse is the duration.

Any actual pulse can only approximate to a rectangular pulse, since the electrical potential or the current flowing at any point takes time to rise or fall to a new value owing to the presence of stray capacitance and inductance in the circuit. The time taken for the voltage to reach its maximum value (or, in the case of a negative going pulse,

the time taken for the voltage to reach its minimum value) is known as the rise time of the pulse or as the duration of its leading edge. The fall time is the duration of the trailing edge. The slope of the leading or trailing edge is often important and may be expressed in volts per microsecond or some similar units. The slope of a pulse edge multiplied by the rise or fall time is equal to the pulse amplitude if the edge is linear. Some pulses are more or less triangular in shape and remain at their peak value for only a very short time; in this case the sum of the rise and fall times is equal to the total duration of the pulse. Other pulses may have curved leading or trailing edges and may have a flat or undulating top. Pulse shapes may be determined by means of an oscilloscope which has an adequate frequency response.

An electronic circuit will not count every type of pulse. A pulse with a duration of a microsecond would be too short for the direct operation of an electro-magnetic register or some types of decade tube. On the other hand if a counting rate above 1 Mc/s is to be attained, the input pulses must have a duration of less than a microsecond or neighbouring pulses will partly coincide. Normally a minimum input pulse amplitude and a minimum duration for which this voltage change should be present are specified as the input requirements for any counting circuit. If the amplitude or the duration of the input pulses are too small, the circuit may not count every pulse. Counting circuits may also become unreliable if the input pulses are many times too large, but the amplitude of large pulses is normally adjusted by the input stages of the equipment before the pulses reach the actual counting circuits themselves. In addition there may be upper and/or lower limits on the slope of one or both of the pulse edges.

Circuits are available which will alter the amplitude and the duration of pulses to a value which is suitable for the operation of a given counting circuit; some of these pulse shaping circuits are discussed later in this chapter. In fact the shape of a pulse is altered somewhat by any amplifier, but this alteration can be kept fairly small by choosing an amplifier which gives constant amplification over a suitably wide range of frequencies.

1.1.3 Resolving Time

If two pulses which are closely spaced together in time are fed into a scaler, only one count will be recorded. If the time interval between the pulses is gradually increased, a point will be reached at which the two pulses will just be counted separately. This time is known as the resolving time or the resolution time of the scaler. An instrument with a small resolving time can count at high speeds.

If a counting circuit has a resolving time of, say, 100 μ sec, it can count at frequencies up to 10 kc/s without any counts being missed provided that the incoming pulses are evenly spaced in time. The pulses will be evenly spaced if they are derived from such things as an electrical oscillator or from a rotating shaft by means of a suitable pick-up device.

In some cases, however, the incoming pulses have a random distribution in time. For example, the particles from radio-active materials are emitted at random times. If two particles which are spaced very closely together in time enter a Geiger tube, only one output pulse will be obtained from the tube. Thus a Geiger tube has its own resolving time (which is normally of the order of 100 μ sec). There is always a certain probability that two particles will enter a Geiger tube within the resolving time of the equipment and the number of nuclear particles counted in a given time will, therefore, always tend to be slightly less than the number which would have been counted if the apparatus had had an infinitesimal resolving time. The percentage of particles not counted (because they enter the Geiger tube at a time which is too close to the time of entry of another particle for each to be resolved individually) will increase as the counting rate increases. The percentage error also increases as the resolving time of the equipment as a whole increases.

The resolving time of a Geiger tube is not normally known accurately, since it varies from tube to tube, with the age of the tube and with the applied voltage. It is normal practice to introduce a resolving time into the counting apparatus which is somewhat longer than the resolving time of the Geiger tube itself, but which is accurately known. The resolving time of the whole apparatus

ELECTRONIC COUNTING CIRCUITS

then becomes equal to this resolving time. Although a larger error is thus introduced, it is possible to correct for this error in the case of random pulses by the method discussed below, since the resolving time is now known.

1.1.4 Correction for Losses due to Finite Resolving Time

Let n = the number of counts recorded per second
 t = the resolving time of the apparatus in seconds

The counting equipment is effectively inoperative for a time of t seconds following each count which is recorded. Therefore, the total inoperative time per second will be nt seconds and the time during which the apparatus is sensitive is $(1-nt)$ seconds for each second of the counting time. The count rate per second, N , which would have been obtained if the apparatus had had an infinitesimal resolving time is therefore:

$$N = \frac{n}{1-nt} \quad (1)$$

This equation is strictly correct only if the particles which enter the Geiger tube during the inoperative periods do not extend the dead time or if the dead time is determined entirely by the resolving time of the preamplifier probe unit or the scaler. Each particle which enters a Geiger tube during the dead time renders the tube inoperative for a further period equal to the tube dead time. In such a case the corrected counting rate, N , may be obtained from the expression:

$$n = Ne^{-Nt} \quad (2)$$

where t is the resolving time of the Geiger tube and e is the base of natural logarithms. This equation should only be used where the dead time is determined entirely by the dead time of the Geiger tube. In any case, equation (1) which is much simpler than equation (2) is accurate enough for most purposes unless the counting rate becomes greater than about $1/10t$. If equation (2) is expanded, it can be shown to be equivalent to equation (1) if Nt is small compared with unity.

As the actual number of particles entering a Geiger tube per second increases, it can be shown

from equation (2) that the count rate will reach a maximum and then decline. A Geiger counter placed in a field of intense radiation can, therefore, indicate a small count rate, since the particles are entering the tube so quickly after one another that the tube is inoperative for a large part of the counting time.

The percentage error introduced at various counting rates for various resolving times is shown in Table 1.1.

Table 1.1

Counts/ sec	Counts/min	Resolving time	Percentage error
10 ⁴	6 × 10 ⁵	1 μsec	1
10	600	1 msec	1
100	6,000	1 msec	10
1	60	100 msec	10

Whilst it is possible to state the approximate maximum rate at which a certain scaling unit will count pulses which are evenly distributed in time, it is obvious from the table that it is not possible to quote a maximum counting rate when the incoming pulses are randomly distributed in time. One can only state the maximum counting rate which will ensure that the percentage of missed counts is kept below a certain value. Any value quoted for the maximum operating frequency of a counting circuit, therefore, refers to the case when the input pulses are evenly distributed in time and when they satisfy the input requirements of the circuit.

If an electro-magnetic register of long resolving time is preceded by a very fast scaling unit which provides one output pulse for each ten input pulses, it might be thought that the maximum operating speed would be ten times that of the electro-magnetic counter alone. This is, in fact, true for pulses which are evenly distributed in time, but in the case of randomly distributed pulses, the maximum counting speed is increased by a factor of more than ten for the same percentage of missed counts. This is because the randomness of the distribution of the pulses in time is reduced by the first fast scaling unit. The percentage of lost counts for such systems has been computed⁽¹⁾.

The resolving time of a counting circuit can be determined experimentally by feeding pulses of known frequency into the circuit from a pulse generator, but care should be taken to ensure that the pulses conform to the specifications for the input to the counting circuit and that the correct power supply voltages are applied to the circuit. Methods are available for the measurement of the resolving time of Geiger counting equipment by means of radioactive sources⁽²⁾.

1.1.5 The Statistics of Counting Random Pulses

If a source of randomly spaced pulses is counted for a number of equal intervals of time, the results obtained will not be exactly the same in each case, but will fluctuate around a mean value in a statistically predictable manner which is determined by the Poisson distribution. If the time for which each set of counts is taken is increased, the actual differences between the results will tend to increase, but the percentage differences will decrease. In radioisotope measurements it is normally desired to find the mean count rate which would be obtained if the counting were carried out over a long time. It is not, however, always convenient to continue the counting for a long time and in any case this would not give the desired result in the case of a short lived isotope. Statistical methods can be used to determine the number of counts which must be obtained to ensure that the probability of a statistical error being greater than a certain percentage of the count is small enough for the result to be acceptable.

A quantity known as the standard deviation is normally used as a measure of the statistical error likely to be present in any particular case. This is the square root of the average value of the square of the individual deviations from the mean. Although the mean count is not known in practice, the square root of the actual number of counts can normally be taken as being equal to the standard deviation without an appreciable error being introduced provided that the number of counts is not very small.

It can be shown that (in the case of random pulses) there is a 31.7% chance that any actual count will differ from the mean count by more than the

standard deviation. If 100 counts are taken, there is, therefore, a 68.3% chance that the statistical error in this one measurement will be less than 10 counts (that is, $\sqrt{100}$). Thus the standard deviation is 10% of the count. In order to reduce the standard deviation to 1% of the count, it would be necessary to take 10,000 counts and there would still be a 31.7% chance (about 1 in three) that the error would exceed 1% of the total number of counts taken. The time necessary to take the requisite number of counts does not enter directly into the statistics.

Although the standard deviation is the most common unit in which statistical deviations from the mean value are expressed, there are two other units which are sometimes used. The probable error is that which has a 50% chance of being exceeded. It is equal to 0.6745 times the standard deviation. The reliable error has a 90% chance of not being exceeded and equals 1.64 times the standard deviation.

It is also useful to note that there is a 95.5% probability that the statistical error does not exceed twice the standard deviation and a 99.7% probability that it does not exceed three times the standard deviation.

The quantities discussed above are useful for checking that the pulses which are being counted are, in fact, randomly distributed in time and that the counting apparatus is not affecting this random distribution. For example, if one finds that a count differs from the mean by more than about 2.5 times the standard deviation, it is almost certain that the equipment is not functioning correctly. The H.T. supply may, for example, be drifting and causing a non-random variation in the counting rate. Similarly a long paralysis time will result in closely spaced pulses being counted as one pulse and the deviations of the results from the mean value will then be less than those which would be expected from statistical considerations.

When a background count is taken and is deducted from the number of counts obtained with a radio-active sample in position, the standard deviation of the resulting net count is equal to the square root of the sum of the squares of the standard deviations of the counts made on the background alone and on the sample plus background. The accuracy with which it is necessary to determine the

background count rate depends on the ratio of the counting rate plus background to that of the background alone. If the sample plus background count rate is little different from that of the background alone, approximately the same length of time should be spent on the determination of the background count rate as is spent on the determination of the background plus sample rate. If, however, the sample plus background rate is about one hundred times that of the background alone, the time spent on the determination of the background rate can be about one tenth of that spent on counting the sample plus background. This results in minimum standard deviation of the net count rate for a given total counting time.

1.1.6. Principles of Counting

The operation of any type of counting circuit other than a ratemeter depends basically on some form of switching from one stable state corresponding to a certain number of counts to another stable state which corresponds to one count more than the previous state. The switching is triggered by the arrival of the input pulses.

Our normal counting system is based on a scale of ten because people first learned to count on their fingers (which are sometimes called 'digits'). When we refer to the number 2,350 we are really using an abbreviated form for the expression: $(2 \times 10^3) + (3 \times 10^2) + (5 \times 10^1) + (0 \times 10^0)$. This system is known as decade counting, or decimal counting, ten different digits being required.

Electronic circuits which count in this manner must have ten stable states in each decade. Each input pulse causes the units decade to advance one position until the tenth pulse returns this decade to the zero state and an output pulse is provided for triggering the second decade which indicates the number of tens. Similarly, the hundredth pulse causes the first two decades to be returned to zero and the third decade to be switched to indicate the digit one. Although decade tube and various other types of circuit have been designed to count in scales of ten, it is not easy to design a simple valve or transistor circuit which has ten stable states. A scale of counting in which fewer digits are employed

is more convenient when valve or transistor circuits are to perform the counting operation.

The simplest counting system of all is the binary scale or scale of two. On the scale of two the number quoted previously (2,350) would be represented as 100100101110 which is really an abbreviated form for the expression: $(1 \times 2^{11}) + (0 \times 2^{10}) + (0 \times 2^9) + (1 \times 2^8) + (0 \times 2^7) + (0 \times 2^6) + (1 \times 2^5) + (0 \times 2^4) + (1 \times 2^3) + (1 \times 2^2) + (1 \times 2^1) + (0 \times 2^0)$.

The only digits which appear in any binary number are 0 and 1, because the next number, two, would be represented as a '1' in the next column, that is as 10. In decade counting there is no single digit to represent any number above nine and similarly in the binary scale there is no single digit to represent any number above one. When the binary system is used the simplicity in the number of different digits employed must be paid for in the actual number of digits which are required to represent a given number. The decade method of writing the number 2,350 requires only four digits, but the binary system requires no less than twelve digits.

Scales other than the binary and decade systems are sometimes used in electronic counting. The scale of twelve is useful for converting pence to shillings and, in combination with a scale of five, for converting seconds into minutes or minutes to hours. A scale of three (ternary) has also been used.

1.1.7 Basic Binary Circuits

Hard valves and transistors are normally used in groups of two in counting circuits, each pair forming a bistable binary counting circuit. At any one time only one of the two valves (or transistors) is conducting, the other being cut off. Normally, circuit diagrams are drawn so that the binaries are in the zero state when the right-hand valve or transistor is conducting. The first input pulse will switch the circuit so that the left-hand valve or transistor conducts and the right-hand one is cut off; this state of the circuit is interpreted as a count of one. A second input pulse will switch the circuit back to its zero state.

A single binary circuit can count only up to one, but larger numbers may be counted if the first binary provides one output pulse (each time it is

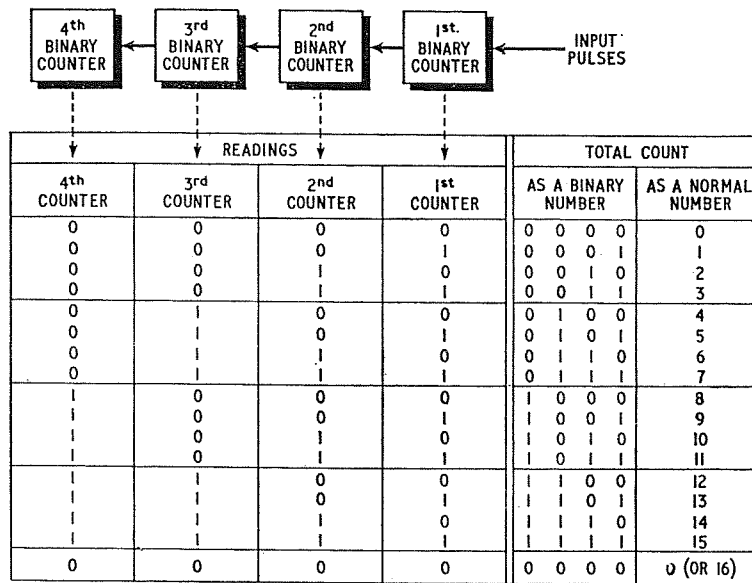

Fig. 1.1. Four cascaded binary counters forming a scale of 16

reset to zero) for each two input pulses which are fed into it. The output pulses may be fed into a second binary stage which will provide one output pulse for each four pulses fed into the first binary circuit. Such a circuit employing two successive binary stages can count up to three.

The four cascaded binary counting circuits shown in Fig. 1.1 can count up to fifteen. If all of the binaries are initially set to zero, the first input pulse fed to the system will cause the first binary stage to register a count, but the other three stages will remain in the zero state. A second pulse applied at the input will reset the first stage to zero and a pulse will be fed from the first to the second binary; the latter, therefore, indicates a count. As this indication is being given by the second binary, it is interpreted as the binary number 10, that is two. A third input pulse causes the first binary stage to indicate a count and leaves the second stage also indicating a count. Thus the total count is the number 11 which is three. A fourth pulse will reset the first binary to zero, the output pulse from this stage will reset the second stage to zero and a pulse from the second binary causes the third stage to indicate a count. Thus the total count is the binary number 100 which is four. Further pulses cause the units to indicate the counts shown in the table of Fig. 1.1. It can be seen that no two lines are the same and,

therefore, the binary system indicates these numbers unambiguously.

Successive binary stages may be added until it is possible to count up to any desired number. If six binary stages are cascaded, the circuit will count up to 63, whilst twelve binary circuits connected in the same way can count up to 4,095. In general, if there are n binary circuits in cascade, the maximum count which can be indicated is $(2^n - 1)$.

Each binary circuit acts as a 'divide by two' stage. The four cascaded binary circuits of Fig. 1.1 act as a 'divide by sixteen' circuit. When the total count is 1111 on the binary scale (that is, fifteen), a further input pulse will reset each of the four binary stages to zero. This is analogous to the resetting of a decade scaler to zero when the count was previously 9,999.

1.1.8 Decade Counting Using Binary Circuits

Most people are much more familiar with a scale of ten than with a scale of two. It is, therefore, usually desirable to employ decade circuits where possible in order to avoid human errors and to achieve a somewhat greater simplicity in reading the state of the count. In the case of valve and transistor counting circuits, it is possible to obtain a decade circuit by converting the scale of sixteen circuit

ELECTRONIC COUNTING CIRCUITS

provided by the four cascaded binary stages of Fig. 1.1 into a scale of ten. This conversion can be accomplished by the use of a suitable feedback or gating system in which six of the counts shown in Fig. 1.1 are automatically omitted.

In principle it does not matter which particular six counts are omitted provided that an output pulse is obtained from the system for each ten input pulses and provided that each of the ten states is represented in a known and unequivocal way. The ten

fourth binary to be switched and a pulse will be fed from this stage to the first stage. This extra pulse will cause the total count to advance to nine on the binary scale. Another seven pulses will be required to cause the binaries to reach sixteen and to reset themselves to zero. The circuit will, therefore, be counting on the scale of fifteen. In practice it may be necessary to delay the fed back pulse slightly so that it does not arrive at the first binary stage at the same time as the end of the input pulse. In some

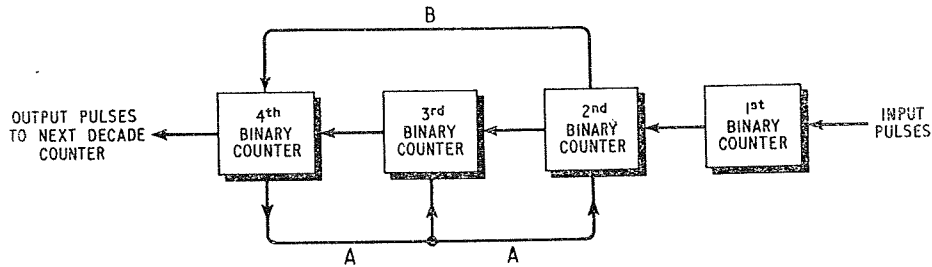

Fig. 1.2 A decade counter using binary counting circuits

digits of a decade can be represented by any ten of the binary numbers shown in Fig. 1.1, the information about the state of the count in the circuit being indicated in a binary code. The ten states may be chosen from the sixteen binary numbers in ${}_{16}P_{10} = \frac{16!}{6!} = 29,059,430,400$ ways. In most

cases, however, the ten states are chosen so that as the decade digit increases, the binary number carrying the information also increases. If this is the case and if the binary zero is always to be used to indicate the zero of the decade, the number of ways in which the ten binary numbers can be chosen is equal to the number of ways in which six binary numbers can be omitted from lines one to fifteen inclusive of Fig. 1.1, no importance being attached to the order in which the six are selected. This number of ways is thus equal ${}_{15}C_6 = \frac{15!}{6! 9!} = 5,005$ ways.

In order to show how feedback can modify the scale in which four cascaded binary circuits count, let us consider the effect of taking pulses from the fourth binary and feeding them to the first binary. The circuit will count up to seven in the normal binary manner, but the eighth pulse will cause the

cases, however, normal delay in the circuit is adequate.

If the pulse from the fourth binary had been fed back to the third stage, it would have added four to the total count. Thus the eighth pulse would cause the total count to increase to twelve on the binary scale and another four pulses would be required before the counter would reset itself to zero. It would, therefore, be counting on a scale of twelve.

One of the numerous methods in which four binary stages can be operated as a decade stage can be illustrated by the block diagram of Fig. 1.2. The system counts up to nine in the normal binary way, the additional connections marked *A* and *B* being ineffective. When the tenth pulse is fed into the system, the first binary counter is switched to read zero and the output pulse from it switches the second binary to indicate a count (actually two counts, since it is the second binary). A pulse from this stage is fed along the connection marked *B* to the fourth stage. This pulse switches the fourth binary to zero and a pulse from it passes along the wire *A* so that the second binary is switched to zero. The switching of this second counter would normally provide a pulse to switch the third binary, but the switching of the third binary can be prevented

by a pulse fed along *A* from the fourth binary to the third binary. All of the binary stages have thus been reset to zero after ten input pulses have been applied.

The system is so arranged that the fourth binary is not affected by the pulse received direct from the second stage along *B* unless it is actually indicating a count at the time (that is, eight counts, since it is the fourth binary). Thus when the second, fourth, sixth and eighth pulses are fed into the system, the pulse from the second binary to the fourth binary has no effect, since the latter is indicating zero.

The necessity for preventing the simultaneous arrival of an input pulse and the fed back pulse at any stage may somewhat limit the maximum frequency of operation of decade circuits which employ feedback. This limitation can be eliminated by the use of diode gating circuits instead of feedback to convert the scale of sixteen to a scale of ten. A gate is either open or closed according to the potential applied to it from one of the binary stages. Each decade consists of four cascaded binary stages but, when a certain number of input pulses have been applied to the circuit, the switching of one of the binary stages causes a diode gate to open so that a succeeding input pulse can pass through the gate and operate one of the later binaries in the decade. A number of states in the scale of sixteen can thus be eliminated and a scale of ten obtained.

Circuits which employ feedback or gating diodes to convert four cascaded binary stages into decade counters are discussed in Chapters 7 and 8 together with the detailed functioning of these systems and their circuitry. Binary stages arranged to operate as decade counting systems are one of the most commonly used types of high speed counting circuit.

1.1.9 Ring Circuits

One form of counting circuit employs devices which have two characteristic stable states—normally conducting and non-conducting. Such devices include trigger tubes and PNP four layer diodes. A number of these devices may be connected in the form of a closed ring so that at any time only one of them is conducting. Each input pulse which is applied to the circuit causes the state of conduction

to move one place in the ring. Each time the ring returns to the zero state, an output pulse is provided for the operation of the succeeding ring. Rings of ten are common, but any number of stages can normally be employed in the ring. A binary circuit may be constructed by using only two stages in the ring.

An alternative arrangement which was used in some of the earlier decade equipment employs a ring of five and a ring of two tubes (or other devices) in each decade. The input pulses may be fed to both rings so that the position of conduction moves one place in each ring as each input pulse is applied. The ring of two tubes indicates whether the total count is an odd or an even number and when taken in conjunction with the ring of five, the state of the count is determined unambiguously. For example, if the ring of five is in the fourth position, it shows that the count in that decade is either three or eight, since the first position corresponds to a count of zero. If the ring of two indicates an even count, the total count is clearly eight. A pulse is fed to the next decade only when an input pulse is received when both rings are indicating their maximum count. In an alternative arrangement the output pulses from a ring of five are used to trigger a succeeding ring of two. The total number of stages in the two rings is only seven when either of these methods are employed, but a single ring of ten stages is normally preferred for decade counting, since the count in each decade is then determined by the state of only one ring. A circuit comprising a ring of five and a ring of two bistable devices may be referred to as a biquinary decade counter.

1.1.10 Readout

Readout is the means by which the quantity which the equipment has counted is displayed for observers to see. A circuit may provide electrical readout in which case an output in the form of electrical pulses or a voltage or current is available. This output carries information as to the state of the count and can be used to operate other circuits.

Some of the devices used for the switching operations in counting equipment are inherently self indicating. For example, digits are displayed by electromagnetic registers, the glowing gas in trigger

ELECTRONIC COUNTING CIRCUITS

and polycathode tubes shows the state of the count, whilst a luminescent strip in the EIT cathode ray decade tube shows the position of the beam. In general, however, such self indicating devices cannot count at the highest possible speeds.

The switching operation of the fastest counting circuits (such as hard valve, transistor, beam switching tube and tunnel diode circuits) does not cause any visible change which can be interpreted as a change in the number of counts. If visual readout is required, some additional components are employed with such circuits to convert the electrical readout from the counting circuit into visual readout.

There are two basic types of readout which can be used to display the state of the count, namely digital and analogue. When a digital readout system is employed, the number of counts is displayed as actual digits. Analogue readout systems show the number of counts in terms of the movement of a meter needle, the movement of a spot of light on the screen of a cathode ray tube or some other physical change in which the actual number of counts is not shown directly.

Electronic scalers are required to count numbers of discrete pulses and not to measure quantities which can vary continuously unless these quantities have first been converted into pulses. Digital readout is, therefore, usually preferred for counting circuits. It has the advantage that it is very easy to read, even in poor light, and errors are, therefore, minimised. In some counting systems a special type of electro-magnetic counter is used to print the number of counts onto a sheet of paper.

Readout from ratemeters is almost always by means of a meter. Digital readout from ratemeters would not be very easy to arrange, as the actual digits are not counted individually; it could, however, be achieved by feeding the output from the ratemeter into a digital voltmeter.

A very common form of readout system involves the use of one additional cold cathode gas filled numerical indicator tube for each decade in the scaler. The indication is given as a glow in the gas contained in the indicator tube. In some types of tube the glow is of such a shape that it forms the digit which is to be indicated. This type of display

is particularly useful, but milliammeters graduated from zero to nine are often used in transistor scalers, since they consume no appreciable power and can operate from the low output voltages available. Other possible forms of readout include the use of tungsten filament bulbs, cathode ray or 'magic eye' indicators, neon bulbs and luminescent display panels.

Further information about readout is given in Chapter 10 and in various circuits throughout the book.

1.1.11 Predetermined Counting

In industrial operations it is often necessary to obtain an output pulse after a preselected number of counts. For example, if articles coming off a production line are to be counted and packed in batches of, say, 144, the preselecting switches in the counter can be set to this number and when 144 articles have been counted, the equipment will provide an output signal which will cause the container for the next batch to be moved into position. Many types of predetermined counter also indicate the total number of batches produced since the equipment was last reset. In many types of equipment it is also possible to obtain an output pulse at any selected count before the end of the batch so that the speed of the production machinery can be reduced immediately before the end of the batch; a second pulse can then be used to stop the production momentarily when exactly the desired number of articles has been placed in the batch.

1.1.12 Choice of Counting Circuit

The type of counting circuit which is most suitable for a particular purpose depends largely on the maximum counting speed which is likely to be required, although various other factors such as size, power consumption, cost, the H.T. voltage required, output facilities, etc. may be important. Circuits which are intended for use at fairly low counting speeds can generally be much simpler in design than those used in high speed scalers.

Although an electro-magnetic counter has the disadvantage of having the longest resolving time

of any type of counter, it has the advantage that one small, compact and reasonably cheap unit can be used to display up to at least six digits. Most gas filled cold cathode decade tubes can count at speeds up to some thousands per second, but two types can count up to one million pulses per second. EIT decade tubes can count at up to about 100,000 pulses per second. Transistor, hard valve and beam switching tube circuits can be constructed with a resolving time of less than one microsecond and can, therefore, be used for very high speed counting, but the circuitry is rather more complicated than is necessary for the slower self-indicating counting circuits. Valve scalers have the disadvantage that they are large and consume a large amount of power—hence they dissipate much heat. Transistor and other solid state scalers can be made very small, consume little power and are very reliable. Transistor scalers are now the most commonly used type of counting circuit in first class modern equipment designed for the highest possible speeds where economy is not of prime importance, but decade tubes are often preferred for medium speed operation.

Semiconductors are still relatively new devices and it appears that a great deal of development work remains to be done on both the devices themselves and on their circuits, especially those intended for very high speed operation.

In order to construct the simplest and most economical scaling equipment which can operate at reasonably high speeds, it is usual to feed the incoming pulses first into a high speed decade which is followed by simpler decades of longer resolving time. Each ten input pulses to the first decade produce only one output pulse from it. The output pulses are, therefore, separated by longer intervals than the input pulses and can be counted by decades of longer resolving time. The circuits of these succeeding decades can be much simpler and less expensive than the first high speed decade. It is usually desirable to have a uniform type of readout from all decades.

Complete scalers covering several decades are not usually constructed using only hard valves to perform the actual counting operations, since after the first one or two high speed valve decades the cir-

uits can be much simplified by the use of slower decades without any reduction in the maximum overall counting speed. Similarly complete scalers are not usually constructed using only beam switching tubes as the scaling elements, since these tubes are fairly expensive and the circuits are not quite so simple as some of the cold cathode decade tube circuits.

The semiconductor devices used in high speed semiconductor decades are usually quite expensive and the circuitry is more complicated than in low speed semiconductor decades. In such scalers the first high speed circuit is therefore usually followed by a simpler circuit of longer resolving time. This may then be followed by a still simpler decade.

One of the most inexpensive arrangements for use with Geiger counters consists of two gas filled decade counting tube stages followed by a four digit electromagnetic register. The first four digits of the number of counts are read from the register, the number of tens from the second decade tube and the number of units from the first decade tube. This arrangement can be used for counting up to 999,999, but the maximum counting speed is not so very much less than that of a scaler employing decade tubes alone. Most of the slightly more expensive scalers for use with Geiger tubes employ decade tubes alone. Electromagnetic registers make a slight noise each time they operate whereas other forms of counting circuit are completely silent.

Magnetic scalers using materials which have rectangular hysteresis loops can be designed for scaling at speeds up to at least one million pulses per second. They have the advantage that they can be made quite small and that their quiescent power consumption is extremely minute.

EIT and beam switching tubes are sensitive to magnetic fields and it would not be wise to use them near to any apparatus containing a large magnet such as an electro-magnetic isotope separator or some types of nuclear particle accelerators.

High speed counting units containing one or two decades are available commercially. They provide output pulses which are normally used to operate a succeeding slower scaler and are known as pre-scalers.

1.2 SOME BASIC PULSE CIRCUITS

In most types of counting circuit various circuits are required for pulse shaping, gating, etc. Some of the most commonly used types of these circuits will now be briefly discussed.

1.2.1 The Differentiating Circuit

One of the simplest types of circuit for changing the shape of a pulse is shown in Fig. 1.3. It is known as a differentiating circuit because the output voltage waveform is approximately equal to the waveform which would be obtained by mathematically differentiating the input waveform with respect to time,

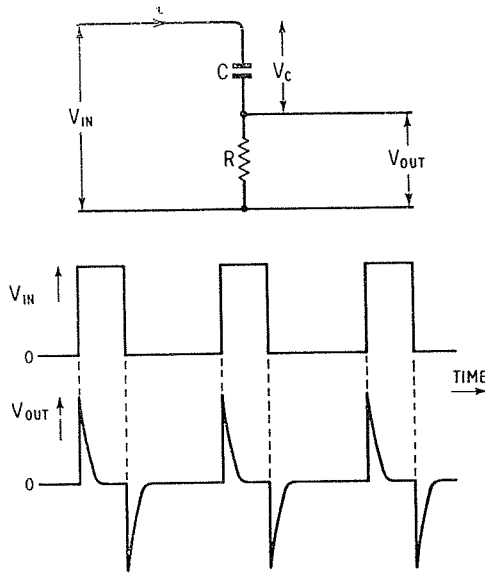

Fig. 1.3 A differentiating circuit

provided that the component values have been suitably chosen. This simple circuit can be used to obtain very sharp voltage pulses from any input pulses which have sharp leading or trailing edges. The differentiated pulses are ideal for synchronisation or for other applications when a sharply defined pulse at a definite time is required.

Let Q = the charge on capacitor C in Fig. 1.3

V_c = the potential across C

$$Q = V_c C$$

Differentiating

$$\frac{dQ}{dt} = C \frac{dV_c}{dt}$$

But dQ/dt is equal to the current i .

$$V_{out} = Ri = RC \frac{dV_c}{dt}$$

provided that the output current is zero.

But $V_{in} = V_c + V_{out}$

If the resistance R is steadily reduced so that the potential V_{out} across it is much smaller than V_c , then V_{in} is approximately equal to V_c . Hence

$$V_{out} = RC \frac{dV_{in}}{dt}$$

approximately. That is, the output voltage is a constant multiplied by the differential of the input voltage with respect to time.

If the input pulses are approximately rectangular in shape as in Fig. 1.3, the leading and trailing edges of the differentiated waveform should coincide with each other. In actual practice, however, the output peaks have a finite width which can be reduced by reducing the value of R , but in a practical circuit this will reduce the amplitude of the output peaks. The product RC is known as the time constant of the circuit. The capacitor of a differentiating circuit presents a higher reactance to low frequencies than to high frequencies. The circuit therefore acts as a high pass filter.

In many circuits a capacitor is used to block a d.c. potential (such as the d.c. potential at the anode of a valve). Some form of resistor is connected on the output side of the capacitor, so the circuit will effectively differentiate the input waveform if the time constant of the circuit is short compared with the pulse duration. If the time constant is long compared with the pulse duration, however, the shape of the pulse may not be appreciably affected by the circuit.

In many applications a diode is connected across the output terminals of the differentiating circuit. This will remove either the positive or the negative going peaks from the output according to the way in which the diode is connected.

1.2.2 The Integrating Circuit

The simplest possible integrating circuit is shown in Fig. 1.4. The output voltage approximates to the integral of the input voltage with respect to time

provided that the component values are suitably chosen.

$$Q = CV_{out}$$

where Q is the charge on capacitor C

$$V_{out} = \frac{Q}{C} = \frac{1}{C} \int i dt = \frac{1}{C} \int \frac{V_R}{R} dt$$

since $dQ = i dt$

$$V_{in} = V_R + V_{out}$$

If R is made large so that V_{out} is much smaller than V_R ,

$$V_{in} = V_R$$

approximately and

$$V_{out} = \frac{1}{C} \int \frac{V_{in}}{R} dt$$

approximately. Thus the output voltage is approximately equal to the integral of the input voltage when R is relatively large and when no current is

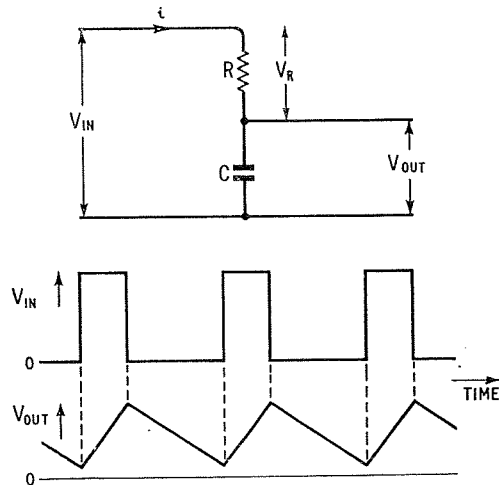

Fig. 1.4 An integrating circuit

taken from the output. It should be noted that only the alternating component of the input waveform is integrated and that the output has the d.c. component from the input superimposed on it. The integrating circuit is a low pass filter.

Much better approximations to a true integrating (or differentiating) circuit can be obtained if the resistor and capacitor are used in the feedback loop of an amplifier. A simple integrating circuit can be constructed in which the capacitor is connected

between the grid and the anode of a single valve amplifier; the effective value of the capacitance is thus increased by the Miller effect.

1.2.3 Multivibrators

The name multivibrator was given to a type of two valve oscillator circuit described by Abraham and Bloch in 1918. The name is derived from the fact that the circuit produces rectangular waves which are very rich in harmonics. The same name has since been given to two similar circuits which are not self oscillating, the only difference in the three types of circuit being the type of coupling between the two valves or transistors. Only hard valve and transistor multivibrator circuits will be discussed here, but similar circuits can be constructed using devices such as trigger tubes and tunnel diodes.

The design of multivibrator circuits is complicated by the fact that the valves or transistors normally switch between the cut off state and the fully conducting state and therefore the small signal equivalent circuits are not applicable. For a full analysis of multivibrator design, the reader is referred to one of the books on this subject⁽³⁻⁶⁾.

1.2.4 The Astable or Free Running Multivibrator

The circuit of Fig. 1.5(a) can exist in two basic states, both of which are unstable. The circuit automatically switches continuously from one of these states to the other, thus forming a relaxation oscillator. The feedback is not frequency selective and, therefore, rectangular waveforms are generated. The astable multivibrator circuit is very useful for generating pulses for testing or operating counting equipment. Either the fundamental or one of the harmonics of the multivibrator can easily be synchronised to an incoming signal; this enables the circuit to be used as a frequency divider.

The astable multivibrator may be considered as a valve amplifier which is resistance-capacity coupled to another valve amplifier stage, the output from the second stage being returned to the grid of the first stage via a similar resistance-capacity coupling. The feedback is thus 100%.

If at any time the grid potential of $V1$ decreases, the anode potential of this valve will increase and

ELECTRONIC COUNTING CIRCUITS

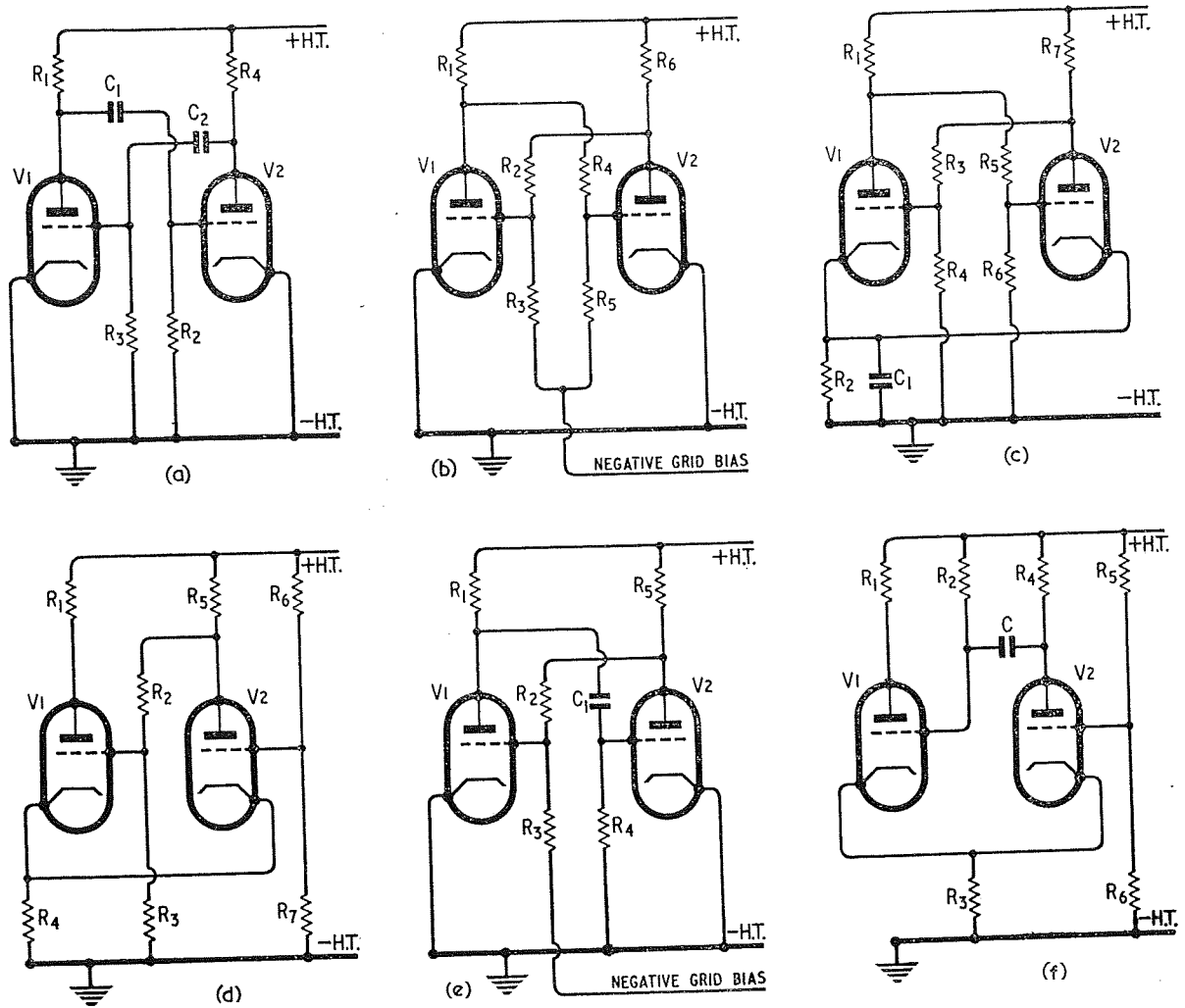

Fig. 1.5 Valve multivibrator circuits. (a) Astable circuit; (b) bistable circuit; (c) bistable circuit with cathode bias; (d) Schmitt trigger circuit (bistable); (e) monostable circuit (flip-flop); (f) cathode coupled monostable circuit

this increase will be coupled to the grid of V_2 . The anode potential of V_2 , therefore, falls and this fall is used to decrease the grid potential of V_1 further. A cumulative effect thus takes place which results in V_1 being cut off. The resulting rise in potential of the anode of V_1 is amplified by V_2 so that the grid of V_1 is held well beyond cut off. This process occurs extremely rapidly so that the potential across the coupling capacitors does not have time to change appreciably during the switching.

Immediately the switching has taken place, the capacitor C_1 (Fig. 1.5(a)) begins to charge exponentially from the H.T. line and some grid current will

flow in the conducting valve, which V_2 , effectively acts as a low resistance shunting R_2 . The time constant for the charging of C_1 is thus reduced from $C_1(R_1 + R_2)$ to an effective value of approximately $C_1 R_1$. The potential of the grid of V_2 will be only a few volts positive above earth potential.

Whilst C_1 is charging, C_2 is discharging through R_3 and is providing a negative potential at the grid of V_1 . The grid of this valve gradually becomes less negative as C_2 discharges and eventually the valve will conduct. This causes the anode potential of V_1 to fall and the fall is amplified by V_2 which leads to a cumulative effect similar to the one described

previously. V_2 will quickly be cut off, whilst V_1 will become fully conducting again. The circuit thus switches continuously between the two states, each valve being cut off in turn. The output may be taken from either anode.

If the values of the components are symmetrical in each half of the circuit, the time for which each tube is cut off per cycle would appear to be identical, that is, the mark to space ratio would appear to be unity. The time for which the circuit exists in one of its states is, however, very dependent on the cut off grid voltage of the non-conducting valve, since the cut off occurs at a part of the exponential discharge curve where the grid voltage is changing relatively slowly towards zero. This effect can be reduced by connecting the lower ends of the grid resistors R_2 and R_3 in Fig. 1.5(a) to the H.T. positive line. The grid voltage of the cut off valve then moves exponentially towards the H.T. supply potential and the cut off voltage will be reached when the grid voltage is changing fairly rapidly. The frequency of operation of the circuit is thus made less dependent on the valve cut off potentials.

The frequency of oscillation of a valve astable multivibrator is given by the approximate equation:

$$f = \frac{1}{(C_1 R_2 + C_2 R_3) \log_e \left(\frac{E_b - E_m}{E_o} \right)}$$

where E_b is the H.T. supply potential,
 E_m is the anode voltage when the grid potential is zero,
 E_o is the grid voltage to cut off the valve under the operating conditions of the circuit.

Various other valve multivibrator circuits can be designed, e.g. one of the couplings may be a common cathode resistor.

1.2.5 The Bistable Multivibrator or Eccles-Jordan Circuit

The circuit of Fig. 1.5(b) differs from that of Fig. 1.5(a) in that there are two d.c. couplings (R_2 and R_4) between V_1 and V_2 . When the H.T. is first applied, some random change will occur which will result in one of the valves being cut off by the same

cumulative process as occurs in the astable circuit. For example, if V_1 is cut off, V_2 becomes fully conducting and its anode voltage falls, ensuring that the grid of V_1 is biased to well beyond the cut off point. The circuit can remain in this condition indefinitely. Similarly, if V_2 is cut off, the circuit will remain in this condition until it is affected by an incoming pulse. Thus this circuit has two stable states.

If a signal of suitable amplitude and polarity is fed to either of the grid or anode circuits, so that the valve which was cut off commences to conduct, a cumulative effect will occur and the circuit will switch into the other stable state. A second input pulse applied to a suitable point in the circuit can be used to switch it back to its initial state. This type of circuit, therefore, provides one output pulse at one of the valve anodes for each two input pulses fed into it. Thus it is a binary counting circuit.

Fig. 1.5(c) is a similar type of circuit, but a cathode resistor is used to provide the bias required by the tubes. One of the two valves is always fully conducting whilst the other is cut off; therefore the bias voltage present across the common cathode resistor is fairly constant.

A slightly different form of bistable circuit known as the Schmitt trigger circuit⁽⁷⁾ is shown in Fig. 1.5(d). In this circuit V_2 is coupled to V_1 as in the two bistable circuits described previously, but the output from V_1 is coupled into the cathode of V_2 by means of the common cathode resistor, R_4 . When V_1 conducts, the voltage developed across the common cathode resistor is appreciably greater than the grid voltage of V_2 , so this valve is cut off. The circuit is very useful for pulse shaping, for example, for converting sine waves into square waves.

In any bistable circuit it is normal practice to place a small capacitor in parallel with the coupling resistors in order to increase the speed of the switching action and to provide an output of shorter rise time. Bistable valve counting circuits are discussed in Chapter 7.

1.2.6 The Monostable Circuit

A monostable multivibrator circuit is shown in Fig. 1.5(e). It has a capacitive coupling from V_1 to V_2 and a resistive coupling from V_2 to V_1 . When V_1

is cut off and $V2$ is conducting, the passage of the $V2$ anode current through R_5 produces a voltage drop which ensures that the grid potential of $V1$ remains well beyond cut off. In this state the circuit is stable for an indefinite time.

If a positive going pulse of suitable amplitude is applied to the grid of $V1$ or a negative going pulse to the grid of $V2$, a cumulative action will take place which results in $V1$ conducting and $V2$ being cut off. The discharging current of C_1 flows through R_4 and causes $V2$ to remain cut off for a limited time. As soon as the potential across R_4 falls to a value which is small enough to allow $V2$ to conduct, the circuit will rapidly switch back to its previous stable state. Thus when $V1$ is conducting the circuit is unstable or, more correctly, it is stable for a limited time only and it will automatically switch back to the state in which it is permanently stable. Another input pulse is then required to trigger it.

Monostable circuits are known as flip-flops because if they are flipped by an input pulse, they will flop back to their initial state after a predetermined time. The time interval between the input pulse and the return to the stable state is determined mainly by the values of C_1 and of R_1 and R_4 in series.

A cathode coupled monostable circuit is shown in Fig. 1.5(f). This may be compared with the Schmitt trigger circuit of Fig. 1.5(d). In each case the output of $V1$ is cathode coupled to $V2$. This type of circuit is very commonly used in counting equipment for shaping pulses (see, for example, some of the circuits in Chapter 4). The grid resistor, R_2 , is returned to the H.T. positive line for the same reason that the grid resistors of astable multivibrators are sometimes returned to the H.T. line, namely that the time at which the circuit returns to its former state is more precisely determined than if the grid resistor is returned to earth.

It is interesting to note that the astable circuit of Fig. 1.5(a) can be converted into a monostable circuit by merely returning one of the grid resistors to a suitable negative potential.

When an input pulse is applied to a monostable circuit, a positive going output pulse which is approximately rectangular in shape may be obtained from the anode of the valve which is normally conducting, whilst a negative going pulse can be

obtained from the valve which is normally cut off. The amplitude and duration of the input pulses which are used to trigger the circuit may vary over quite a wide range, but the amplitude and duration of the output pulses from the monostable circuit are independent of the input pulse characteristics. Monostable circuits are therefore extremely useful for shaping and controlling the duration of pulses. They may also be used to produce a delay (by using the trailing edge of the output pulse) or to put a piece of equipment out of action for a brief pre-set time following the application of an input pulse to the circuit.

1.2.7 Transistor Multivibrator Circuits

Transistor circuits which are exactly analogous to the valve circuits of Fig. 1.5 can be designed. Some typical examples are shown in Fig. 1.6. In each of these circuits one of the transistors is fully cut off at any one instant and the other is fully conducting. A fully conducting transistor is said to be 'bottomed' because the collector potential is little different from the emitter potential (which is often earth potential). If a transistor is cut off, the current passing through it is very small whilst, if it is bottomed, the potential difference across it is small. In either case the power being dissipated in the transistor is small, so it is not usually necessary to employ any components which will give protection to the transistor against possible thermal runaway.

1.2.8 Astable Circuits

A transistor astable circuit is shown in Fig. 1.6(a). If the transistor $T1$ is bottomed and $T2$ begins to conduct, the positive pulse at the collector of $T2$ will be fed to the base of $T1$ and will reduce the current taken by this transistor. The resulting negative pulse at the collector of $T1$ is fed to the base of $T2$ where it causes the collector current to increase. A cumulative effect thus takes place which results in $T1$ being rapidly cut off and $T2$ being bottomed. C_2 begins to discharge through R_3 and the output circuit of $T2$ so that after a time the base potential of $T1$ will fall somewhat and this transistor will

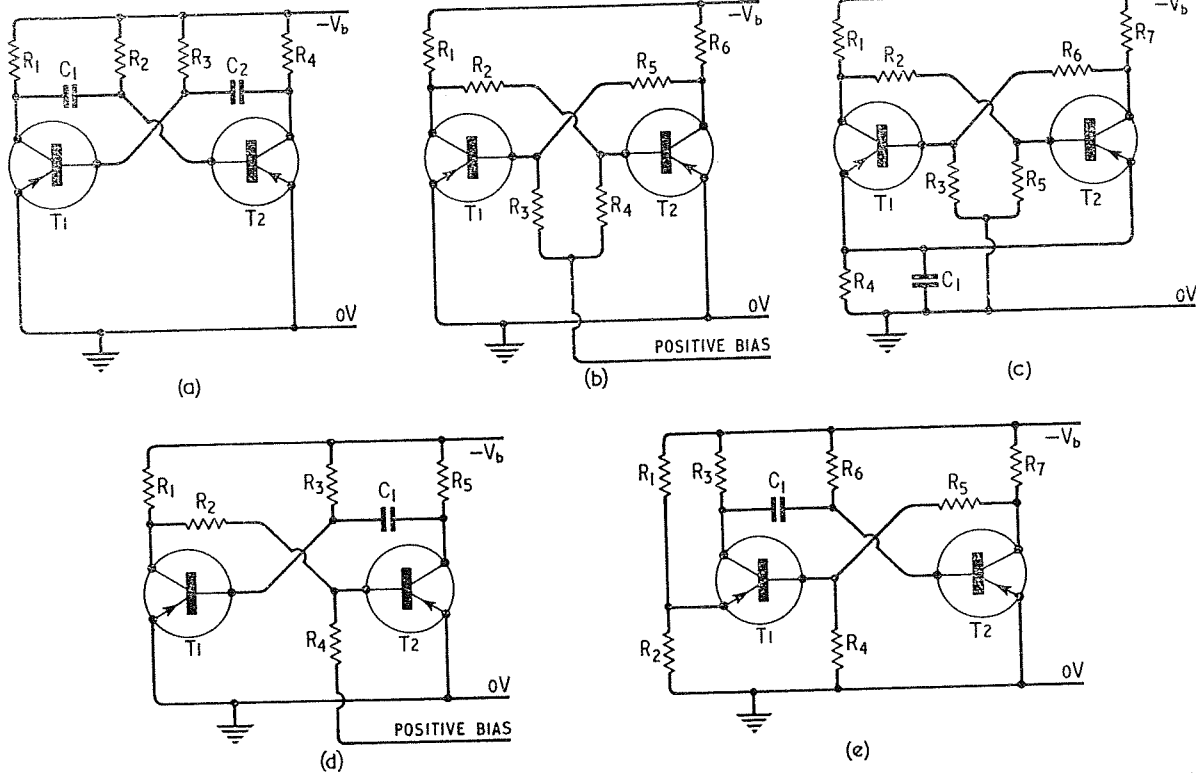

Fig. 1.6 Transistor multivibrators. (a) Astable circuit; (b) bistable circuit; (c) self biased bistable circuit; (d) monostable circuit; (e) monostable circuit

commence to conduct. This will result in a switching action taking place and T_2 will be cut off.

If T_1 is initially cut off, the collector of this transistor will be at the full negative supply potential (ignoring the leakage current of T_1), whilst at the other side of the capacitor C_1 the base of T_2 will be at about earth potential (actually slightly negative with respect to earth). Thus the right hand side of C_1 is at approximately $+V_b$ volts with respect to the other side of the capacitor. When T_1 suddenly bottoms, the potential of its collector will become approximately zero. The charge on C_1 cannot change instantaneously and, therefore, the potential of the base of T_2 becomes $+V_b$ with respect to earth. T_2 is therefore cut off. As C_1 discharges the potential of the base of T_2 commences to fall exponentially from $+V_b$ towards $-V_b$ but, as soon as the base reaches approximately the earth potential, T_2 conducts and the switching process takes place. This occurs when the potential of the transistor base has moved half way from $+V_b$ to $-V_b$. The poten-

tial, V , across the discharging capacitor is given by the equation:

$$\frac{V}{V_0} = e^{\frac{-t}{RC}}$$

where V_0 is the potential of the supply from which the charging takes place,
 t is the time since the charging commenced,
 R is the resistance through which the charging current is passing,
 C is the capacitance.

Hence

$$t = RC \log_e \left(\frac{V_0}{V} \right)$$

In order to find the time taken for the base of T_2 to reach zero volts, a value of 2 is substituted for V/V_0 , since C_1 charges half way towards the value which it would reach if the switching action did not occur. The output impedance of T_1 is usually small compared with R_2 and therefore may be neglected in the equation.

ELECTRONIC COUNTING CIRCUITS

Hence $t = R_2 C_1 \log_e 2$ approximately
or

$$t = 0.7 R_2 C_1$$

When $T1$ has been switched to the conducting state, a time t will pass before $T2$ is switched into its conducting state. Hence the frequency of oscillation of the circuit is given by:

$$f = \frac{1}{0.7(R_2 C_1 + R_3 C_2)}$$

approximately.

The output may be taken from either collector, the pulses being approximately rectangular in shape. The edge of an output pulse caused by a transistor being switched to the conducting state is steeper than that caused by a transistor being cut off, since the cut off time is limited by hole storage effects and circuit time constants. The waveform at the transistor bases has a steep leading edge when the transistor commences to conduct and an exponential trailing edge.

1.2.9 Transistor Bistable Circuits

A simple bistable transistor circuit is shown in Fig. 1.6(b). This circuit is very similar to the valve bistable circuit, since it has two resistor couplings and may be switched from one state to the other by an input signal of appropriate polarity and amplitude applied to either the base or the collector of a transistor. If the cut off transistor is made to conduct or if the bottomed transistor is cut off, the circuit will be switched to the other state.

In practical circuits small capacitors are normally placed in parallel with R_2 and R_3 of Fig. 1.6(b) so that the pulses generated have steep edges. If these components are not used, the high frequency components of the pulses from the collector of one transistor are effectively shorted out by the input capacitance of the transistor to which they are fed.

In the bistable circuit of Fig. 1.6(c), the bias has been obtained by means of a resistor in the emitter circuit. The resistor is decoupled with a capacitor in order to preserve the steep sides of the output waveform.

Various asymmetrical bistable circuits have been designed including some especially interesting ones

in which a PNP transistor is employed in conjunction with an NPN transistor. No valve circuits similar to this type of circuit can be constructed.

Transistor bistable circuits, like the corresponding valve circuits, provide one output pulse for each two input pulses. They can, therefore, be used as binary counting circuits and will be discussed more fully in Chapter 8.

1.2.10 Transistor Monostable Circuits

The circuit of Fig. 1.6(d) is stable only when $T1$ is bottomed and $T2$ is cut off. If a suitable input pulse is applied to the circuit, $T1$ will be cut off and $T2$ will conduct. After a short time, however, the circuit will return to its stable state. The time interval before the circuit returns to its stable state is the time taken by C_1 to discharge from the potential of V_b to about earth potential. This interval is given by the following equation which may be derived by the same reasoning as that given in the case of the astable transistor circuit.

$$t = 0.7 C_1 R_3$$

Positive going pulses may be taken from the collector of $T2$ or negative going output pulses from the collector of $T1$. In order that the output pulses shall be as nearly rectangular as possible, it is usual to connect a small capacitor across the resistor R_2 .

Another type of monostable circuit is shown in Fig. 1.6(e). This circuit is stable when $T1$ is cut off and $T2$ is bottomed.

1.2.11 The Blocking Oscillator

In the multivibrator two valves or transistors are employed to provide the phase inversion required for the feedback to be positive, but in the blocking oscillator the phase inversion is obtained by the use of a transformer; only one valve or transistor is therefore required. A blocking oscillator circuit may be monostable or astable.

The basic circuit of a free running or astable valve blocking oscillator is shown in Fig. 1.7(a). The percentage feedback is made large. When the circuit is first switched on, the anode current flowing

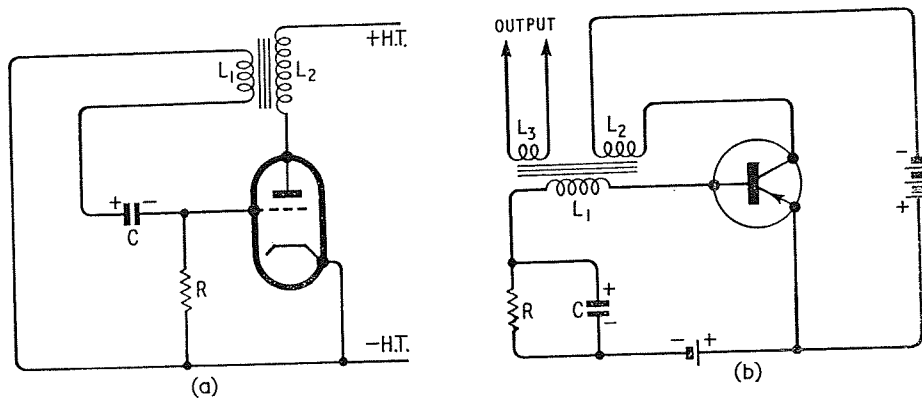

Fig. 1.7 Blocking oscillator circuits

through L_2 increases and induces a voltage in L_1 of such a polarity that the valve grid becomes more positive. Grid current flows through R and the capacitor is charged with the polarity indicated in the circuit. The cumulative effect quickly causes the anode current to reach a maximum, after which the current in L_2 is almost constant so that the potential across L_1 becomes zero. C_1 now biases the grid negatively and, as the anode current commences to fall, L_1 provides a potential which reduces the grid potential still further. The valve is therefore rapidly cut off by this cumulative effect. The capacitor then discharges through R exponentially and the grid of the valve gradually becomes less negative and eventually the valve conducts. The anode current flowing through L_2 causes a positive potential to be applied to the valve grid which increases the anode current still further. The valve is thus quickly driven into saturation again. C_1 charges and the whole process is repeated.

The valve anode potential consists of a negative pulse followed by a positive pulse; it then remains constant until the succeeding negative pulse occurs. The Q of the transformer winding is normally made low so that the oscillations which result from shock excitation of the transformer windings are kept to a small amplitude.

If the grid resistor is returned to a potential which is negative with respect to the cathode potential by an amount greater than the cut off potential of the valve, the circuit becomes monostable. A positive going pulse fed to the grid will trigger the circuit and a pulse of fairly high amplitude may be taken from the anode.

A transistor blocking oscillator circuit is shown in Fig. 1.7(b). The feedback is from the collector of the transistor to the base. When the supply voltages are first connected, the transistor will conduct owing to the negative potential applied to the base relative to the emitter. The transformer windings are arranged so that the increasing collector current flowing through L_2 renders the base more negative and this tends to increase the collector current still further. The transistor is, therefore, quickly bottomed. The capacitor C becomes charged during this time with the polarity indicated in the circuit. When the collector current reaches a maximum, the potential across L_1 falls to zero and the positive potential applied to the base from the capacitor C causes the collector current to be reduced. The effect of this reduction is fed back via L_2 and L_1 , thus producing a cumulative effect at the end of which the collector current is cut off. C discharges through R and after a short time the base voltage reaches such a value that the transistor conducts.

A cumulative effect causes the transistor to be rapidly bottomed. The cycle is then repeated again.

Monostable transistor blocking oscillator circuits offer a very economical way of using transistors to drive counting circuits such as cold cathode decade tubes which require a fairly high pulse amplitude, since a fairly large number of turns may be placed on the output winding L_3 of the blocking oscillator transformer to obtain a large amplitude pulse. A low voltage transistor may be used in the blocking oscillator circuit. The transformer is often constructed on a ferrite core.

1.2.12 The Diode Clamping Circuit

A diode is often used in pulse circuits to prevent the potential of a certain point from rising above or falling below a certain voltage. In the circuit of Fig. 1.8 the output from the pulse amplifier V_1 is fed through the capacitor C . If the time constant CR is small, the pulse will be differentiated. If at

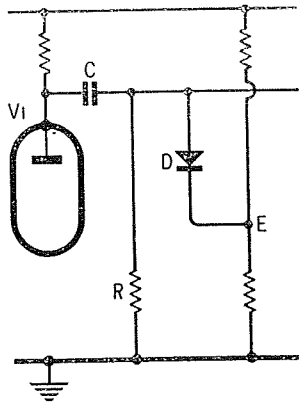

Fig. 1.8 A diode clamping circuit

any time the output potential tends to become more positive than the potential at the point E of the potential divider, the diode D will conduct and the output potential will not rise much above E .

A similar method may be used to prevent the potential at a point in a circuit from falling below a certain potential. In some cases the potential at a point may be clamped to both an upper and a lower value. Unless the pulse amplitude at this point is small, it is then completely determined by the values of the potentials to which the point is clamped. The pulse amplitude may thus be made independent of the characteristics of valves in amplifier stages.

1.2.13 Gating Circuits

An electronic gate is a device which either allows pulses to pass or prevents them from passing; that is, the gate is either open or closed. The simplest form of a gate is a diode in series with a pulse source. If the diode anode is more positive than its cathode, the gate will be open and vice-versa.

Simple gates enable counting circuits to be used for the accurate measurement of time. Pulses from

an oscillator pass through the gate when it is open to the counting circuit. The gate may be opened by a beam of light falling on a photocell. If the frequency of the oscillator is known, the time for which the gate was open can be deduced from the number of counts recorded.

1.2.14 The and Gate or Coincidence Circuit

The AND gate is a circuit which will provide an output pulse only when a number of simultaneous input pulses are fed to it. A simple type of AND gate is shown in Fig. 1.9. If a positive going input pulse is applied to D_1 , this diode will be biased so that it has a high resistance. If no pulses are applied to D_2 and D_3 , these diodes will be biased in the forward direction by the pulse applied to D_1 . The diode D_1 forms the upper part of a potential divider, the lower

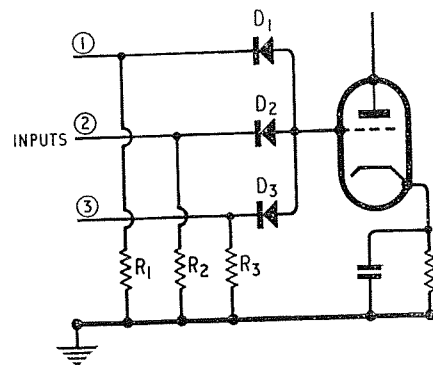

Fig. 1.9 An 'AND' gate

part of which consists of a parallel combination of the other two diodes each in series with a resistor. When D_1 is in its high resistance state, it has a resistance which is much greater than the sum of the forward resistance of one of the other diodes and one of the resistors, R_1 , R_2 and R_3 . The voltage at the grid of the valve is, therefore, almost unaffected by the application of a positive pulse to D_1 alone. Similarly the application of a positive pulse to any other diode or the simultaneous application of positive pulses to any two diodes will leave the grid potential of the valve virtually unchanged, since the diode or diodes which are receiving no pulse will be held in their low resistance state and will effectively short the valve grid to earth.

If, however, positive pulses are applied to all three of the diodes simultaneously, the grid of the valve will receive a positive potential with respect to earth, since the valve input impedance is much greater than the reverse impedance of the diodes.

Thus the valve receives a positive pulse if, and only if, positive pulses are fed to all three of the diodes simultaneously. Although three diodes are shown in Fig. 1.9, any reasonable number of diodes from two upwards can be used if a greater number of input channels is required. If the incoming pulses are negative going, the connections of the diodes in Fig. 1.9 should be reversed.

Another type of coincidence circuit employs a multi-grid valve such as a hexode in which two of the grids are normally biased so that either would cut off the anode current. The anode current will only flow if positive going pulses are received simultaneously by both of the grids, in which case a negative going pulse is produced at the anode.

The Rossi coincidence circuit employs a number of pentodes which have a common anode resistor of a fairly high value. The number of pentodes used is equal to the number of input channels required. When one or more pentodes conduct, the common anode potential falls to about 20 V. A positive going output pulse is obtained from the anodes if, and only if, all of the pentodes receive simultaneous negative input pulses so that they are all cut off.

A transistor coincidence circuit is shown in Fig. 1.10. Current can only pass through the series connected transistors when coincident negative going pulses are fed to the two inputs. The positive bias is large enough to cut the transistors off in the absence of input pulses.

Coincidence circuits are used in many predetermined counting circuits and are also used in certain

radio-isotope measurements. Anticoincidence circuits are also used in isotope measurements; this type of circuit allows a pulse to pass through it provided that a simultaneous pulse is not being received from another source.

1.2.15 The or Gate

An OR gate provides an output pulse whenever a suitable pulse is applied to any input channel of the circuit. It also serves the purpose of isolating the various input channels from each other.

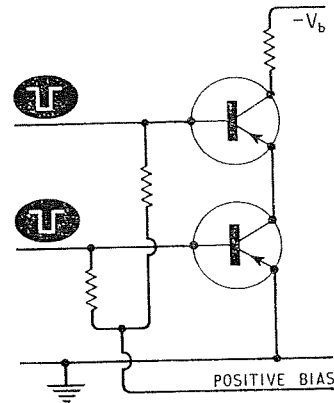

Fig. 1.10 A transistor coincidence circuit

The AND gate of Fig. 1.9 will become an OR gate if the input pulses are negative going. It can be seen that negative going input pulses will pass through the diodes, but will not be able to pass into any of the other input channels without passing through the high reverse resistance of one of the other diodes. If the polarity of the diodes is reversed, the circuit becomes an OR gate for positive going pulses. Other types of OR gate are also available.

REFERENCES

1. L. ALAOGU & N.M. SMITH, JR. 'Statistical theory of a scaling circuit', *Phys. Rev.*, **53**, 832 (1938).
2. T.W. PACKER. 'The determination of the paralysis time of an electronically quenched probe unit', A.E.R.E. Report M1109 (1962).
3. P.A. NEETESON. *Vacuum Valves in Pulse Technique*, Philips Tech. Library, 2nd Ed. (1959).
4. P.A. NEETESON. *Junction Transistors in Pulse Circuits*, Philips Tech. Library, (1960).
5. C. LE CAN. *The Junction Transistor as a Switching Device*, Philips Tech. Library (1961).
6. P.A. NEETESON. *Analysis of Bistable Multivibrator Operation*, Philips Tech. Library (1960).
7. O.H. SCHMITT. 'A thermionic trigger', *J. Sci. Inst.*, **15**, 24 (1938).

Electro-Magnetic Counters

The simplest type of counter is the electro-magnetic register, also known as the electro-mechanical register. The mechanism of this type of counter is very similar to that of a relay. When a current pulse flows through an internal electro-magnet, a soft iron armature is attracted and is subsequently released at the end of the pulse. The armature operates a pawl and ratchet system which in turn moves a small drum on which the units digits are painted. When the units drum moves from 'nine' to 'zero', the drum which indicates the number of tens is advanced one position by means of a mechanical linkage from the units drum. The type of display (as can be seen from Plates 1 and 2) is similar to that of the mileage indicator of a car. The maximum operating speed of electro-magnetic counters varies from about 5 to 50 pulses per second according to type. They have a longer resolving time than any of the other counting systems to be discussed, but are very useful as compact multi-decade slow counters and for adding to faster decades to increase the capacity of the latter by several digits.

Initially electro-magnetic counters were used by the Post Office to register the number of local telephone calls made by a subscriber. The types of four digit Post Office register (type 100A, 100B or 100C) used for this purpose are comparatively cheap, but they have a long resolving time (about 0.1 to 0.15 sec), cannot be reset to zero and have a relatively short life (about 250,000 counts). When such a counter ages, some counts are missed and eventually the unit will completely cease to function. The power required to operate these counters is of the order of 3 W for not less than 50 msec. The most common value of the coil impedance of

the electro-magnet is 2,300 Ω , but other values of coil impedance are available. In the past, Post Office registers have been used in many scaling units after high speed valve decades.

Many types of precision electro-magnetic counters are now available which have a very much longer life (over 10^8 counts) and which usually have a somewhat shorter resolving time than the Post Office types. Some types can be reset by means of a switch, a lever or a push-button, whilst others can be reset by the application of a suitable pulse to an additional electro-magnet inside the counter. Counters which are reset to a number other than zero are also obtainable. The number of digits indicated can vary from one up to at least seven. Small electro-magnetic counters are available to indicate time in hours, minutes and seconds. Other types of counter contain two electro-magnets and can be used for forward or reverse counting. Some counters print out the number of counts onto a roll of paper instead of, or in addition to, the normal type of electro-magnetic counter readout. An internal rectifier is fitted in some counters so that they can be operated directly from a pair of contacts placed in series with the counter across the a.c. mains supply.

Electro-magnetic counters are available with a wide range of coil impedances. If a counter with a maximum speed of ten counts per second is to be fed from a transistor circuit, a nominal 20 Ω coil which passes about 0.3 A at 6 V may be suitable. A similar counter fed from a valve circuit requires a coil of a higher impedance; for example, a coil of nominal impedance 5,800 Ω which will pass about 19 mA at 110 V may be suitable. In either case the power fed into the coil is about 2 W for 40 msec.

Counters which have a greater maximum operating speed than ten pulses per second will normally require a pulse of larger power for a shorter time. If a counter employs magnetic reset, a pulse of about 8 W for 200 msec is required in most cases to reset the unit. The pulse current and voltage must, of course, be approximately matched to the coil impedance. It should be noted that in many cases the coil ratings are for pulsed operation only, and overheating may occur if the power is applied continuously to the coil for a few minutes.

It is possible to design magnetic counters for operation at quite high speeds (over 10 kc/s), but the amount of movement is microscopic and the construction often resembles that of a moving coil loudspeaker. In such systems the moving parts must be very light in weight in order to achieve high speeds and, therefore, wear may be excessive. Readout is normally effected by means of a beam of light.

An interesting system has been described by Bennett⁽¹⁾ which consists of a continuously running motor and a light electro-magnetically operated clutch. When an input pulse actuates the clutch, the motor moves a pointer which indicates the units and tens. A further four digits are displayed on small drums which can be reset. The system can operate at over 50 pulses per second and showed no signs of wear after 10^8 counts at this speed.

Counting at speeds above 100 pulses per second can normally be carried out much more satisfactorily by the use of purely electronic devices (at least in the first decade) than by electro-magnetic counters, since the latter have inertia and are subject to wear. At the moment it seems most unlikely that much further effort will be made to design counters which employ moving parts for operation at frequencies in excess of about 100 pulses per second.

2.1 PREDETERMINED COUNTERS

Electro-magnetic predetermined counters are manufactured by a number of companies and are very useful for industrial batching operations, etc., where the maximum counting rate does not exceed about 25 impulses per second. The counters are preset to the desired number and each input pulse

will then reduce the number indicated by unity until the zero position is reached, when a set of contacts inside the counter will be operated. This set of contacts can be used to cause any desired operation to be performed and (if the unit is equipped with magnetic reset facilities) the counter can be automatically preset to the same number as before. Alternatively the resetting can be carried out manually. Contacts may also be fitted to some types of predetermined counters so that a warning is given at a certain number of counts before the zero is reached.

In the Sodeco preset counter shown in Plate 2, the preset number can be made to appear by pushing the button at the front of the instrument. If the button is pushed and turned through 90° , the hinged cover above the numbers may be opened and the knurled drums which are located under the cover can be adjusted until the desired number appears. These counters are available with various coil impedances and also with internal rectifiers for operation from a.c. mains.

2.2 CIRCUITS FOR DRIVING ELECTRO-MAGNETIC COUNTERS

If an electro-magnetic counter is to be operated from a pair of contacts which periodically close, the counter may be merely connected in series with the contacts and a suitable source of a steady potential. Care should be taken that the contacts are closed for a time which is long enough to ensure satisfactory operation of the counter, but not for the coil of the counter to become overheated.

A considerable amount of sparking can occur at the contacts in series with the counter owing to the voltage induced in the coil of the counter when the current ceases to flow through it. This sparking can damage the contacts, especially if they are small, and will eventually lead to counting errors. There are a number of methods by which sparking at contacts can be reduced, but their efficacy varies considerably with the type of coil and the type of contacts employed⁽²⁾.

It has been found that one of the most satisfactory methods of spark suppression in many types of counter involves the use of a resistor and a capacitor in series across the contacts. The optimum

ELECTRONIC COUNTING CIRCUITS

values of the resistor and capacitor vary widely with the type of counter. A 110 V Sodeco TCe counter rated at 10 pulses per second may employ a $0.2 \mu\text{F}$ capacitor and a resistor of 2.5 to 5.5 $\text{k}\Omega$ for spark suppression, whilst a 20 Ω counter of the same type can be used with a $0.5 \mu\text{F}$ capacitor and a 68 Ω resistor. Larger capacitors and smaller resistors are required for counters designed to operate at up to 25 pulses per second. Full details of the optimum values of spark suppression components for use in this type of circuit have been published⁽²⁾.

Various other methods of spark suppression are possible. For example, a resistor of about 5 $\text{k}\Omega$ may be connected in parallel with the counter coil. A capacitor may also be required in parallel with both the resistor and the coil⁽²⁾.

If a counter coil is rated at between about 20 and 160 V, a voltage dependent resistor may be connected across it to short circuit the voltage produced in the coil when the contacts open. The Mullard voltage dependent resistor type E299DE/P232 is suitable for coils rated at 20 to 48 V, the E299DE/P338 for 60 V coils and the E299DE/P342 for 72 to 110 V coils. This method of spark suppression is not normally so satisfactory as that using a series resistor and capacitor connected across the contacts.

In magnetically reset counters the sparking at the resetting contacts may be reduced by the same methods, but the optimum values of the components are somewhat different to those required for spark suppression at the contacts in series with the main counter coil⁽²⁾.

If the contacts are small and they must have a long life, only a small current should be passed through them. Some form of electronic switch should therefore be employed to amplify the small current passing through the contacts to a value which can operate the counter. The circuit of Fig. 2.1 shows a valve circuit which may be used for driving an electro-magnetic counter from two contacts. The current which passes through the contacts *S* is negligible. This circuit is based on a Sodeco publication⁽³⁾ for their ranges of TCe counters. The valve is normally biased to cut off, but when the contacts are closed, the grid becomes less negative so that an anode current can flow and operate the counter. The value of the resistor *R* should be adjusted so

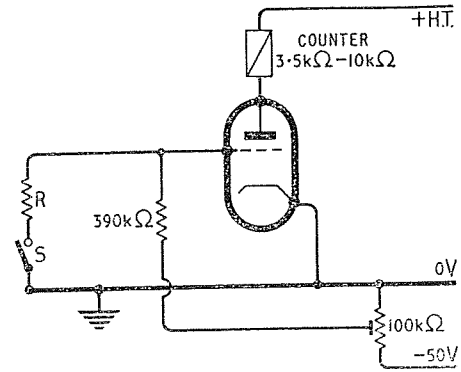

Fig. 2.1 The operation of a counter from a pair of small contacts

that a suitable current passes through the counter when the contacts are closed. If counting rates not exceeding ten pulses per second are required, a counter rated at 3.5 to 10 $\text{k}\Omega$ at 15 mA may be employed with an E90CC double triode; one section of the valve may be used or both sections may be connected in parallel. For higher counting rates or for counters requiring more current, a valve which can pass more anode current should be used. For example, a 6AQ5 may be used with a counter coil rated at 5.8 $\text{k}\Omega$, 38 mA; the screen grid should, of course, be connected to a suitable positive potential.

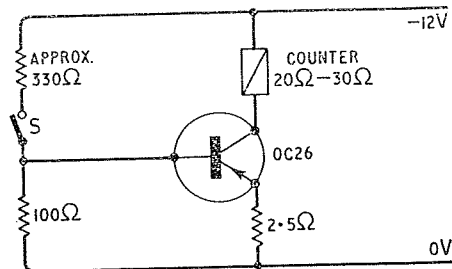

Fig. 2.2 A transistor circuit for the operation of a counter from a pair of small contacts

A similar circuit employing a transistor and a counter coil of much lower impedance is shown in Fig. 2.2⁽⁴⁾. When the contacts *S* are closed, a current of about 30 mA passes through them and in the base circuit of the transistor. The amplifying action of the transistor allows a current of about 0.5 A to flow through the counter. The component values should be chosen so that the collector current is

normally almost zero, but when S is closed, it should rise to a value suitable for the operation of the counter and the potential between the collector and emitter should fall to a very small value. In either of these states the heat being dissipated in the transistor is small.

In many applications it will be required to operate an electro-magnetic counter from input pulses which have a duration longer than those required to operate the counter. In this case a differentiating circuit followed by an amplifier can be used, a typical case being shown in Fig. 2.3⁽³⁾. If the input pulses are negative going, a phase inverting stage, $V1$ (shown dotted), will be required, but if the input pulses are positive going and of a suitable ampli-

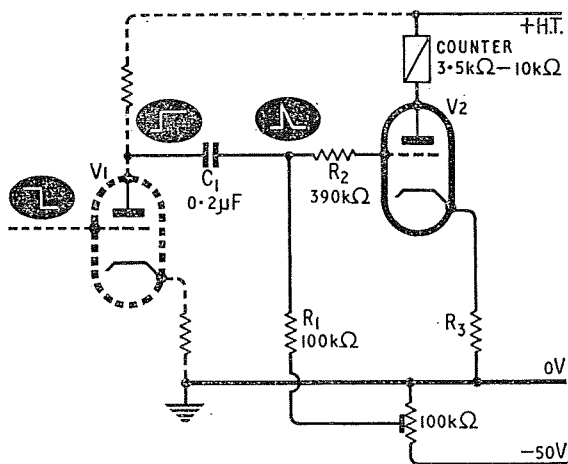

Fig. 2.3 A circuit for the operation of a counter from long input pulses

tude, they may be fed directly to C_1 . When the long input pulse is differentiated by $C_1 R_1$, it will be turned into a short positive going pulse which is fed to the grid of $V2$. Thus the anode current flows through $V2$ and the counter for a time which is little longer than that necessary for the operation of the counter. This ensures that the heat generated in the coil is minimised and enables a fairly small valve to be used. The value of C_1 and/or of R_1 may be adjusted to obtain a pulse of a suitable length for the operation of the counter used. The cathode resistor R_3 should be chosen so that the anode current of $V2$ remains below the maximum permissible value for the valve when the grid is earthed. R_2 limits the grid current. The type of valve and the value of the coun-

ter coil impedance may be similar to those of the circuit of Fig. 2.1, but as there is no possibility of the valve $V2$ conducting for more than a small fraction of a second, it may be possible to use a valve with a smaller anode current rating than that used in Fig. 2.1.

A similar circuit employing a transistor⁽⁴⁾ is shown in Fig. 2.4. The negative going input pulses are differentiated by $C_1 R_1$. The value of R_1 must

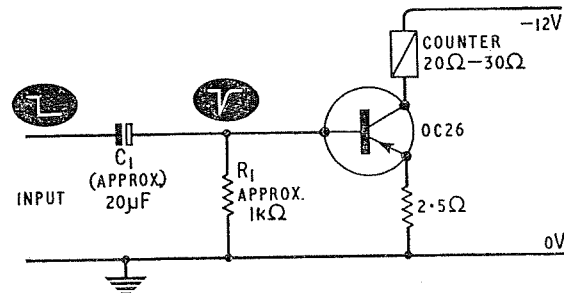

Fig. 2.4 A transistor circuit for the operation of a counter from long input pulses

normally be fairly small and thus C_1 must be fairly large in order to obtain a suitable pulse duration. C_1 is normally an electrolytic capacitor.

2.2.1 Monostable Circuits

If the input pulses are of short duration, a monostable circuit can be used to increase their length to a certain predetermined value which is great enough to ensure reliable operation of the counter. If the maximum speed of the counter is to be attained, a monostable circuit is in any case desirable, since it can supply pulses of the optimum waveform (that is, rectangular). A suitable monostable circuit which has been designed for Sodeco counters is shown in Fig. 2.5⁽³⁾. In the quiescent state the left hand triode is conducting whilst the right hand triode is cut off; the current through the counter is therefore very small. A negative input pulse will trigger the circuit and cause the right hand triode to conduct. The circuit will return to its quiescent state after a preset time which is almost independent of the duration of the input pulse. The duration of the pulse applied to the counter may be altered by changing the value of C . Under suitable circumstances this circuit may be used to operate Sodeco

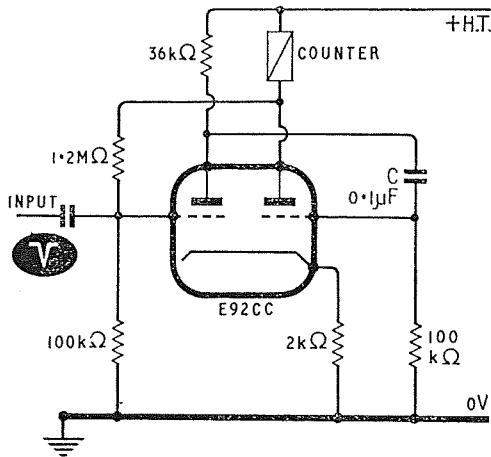

Fig. 2.5 A monostable circuit for the operation of an electro-magnetic counter

counters at speeds exceeding 25 pulses per second. Units consisting of the above circuit plus a suitable power supply are available commercially⁽³⁾.

Some types of counter may require a higher operating current than that provided by the circuit of Fig. 2.5. In this case a valve which has a higher cathode current rating should be used to feed the counter, as in the monostable circuit of Fig. 2.6. In the quiescent state V_1 is conducting and V_2 is cut off. A negative going pulse of about 1 V applied to the grid of V_1 for at least 200 μ sec will trigger the circuit. When V_2 conducts, the current passing through it

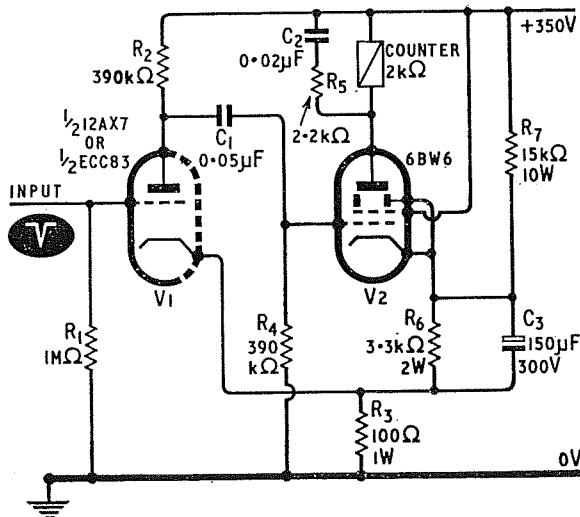

Fig. 2.6 A monostable circuit providing large current pulses

also passes through the common cathode resistor R_3 and so provides the positive feedback required to cut off V_1 . As C_1 charges, a point will be reached at which V_2 is cut off and V_1 conducts again. The capacitor and resistor in parallel with the counter coil suppress the voltage pulse when V_2 is cut off. The value of C_1 may be adjusted to obtain the desired pulse duration. With the value shown, the pulse is applied to the counter for about 25 msec. If a Post Office register is being used, the value of C_1 should be increased to about 0.1 μ F, since a Post Office register cannot record more than about ten counts per second. The pulse which passes through the counter has a rectangular top with a peak value of approximately 100 mA. The circuit will oscillate if the bias supplied to the cathode of V_2 is not great enough to cut the anode current off, but if the bias is excessive, large input pulses will be required to

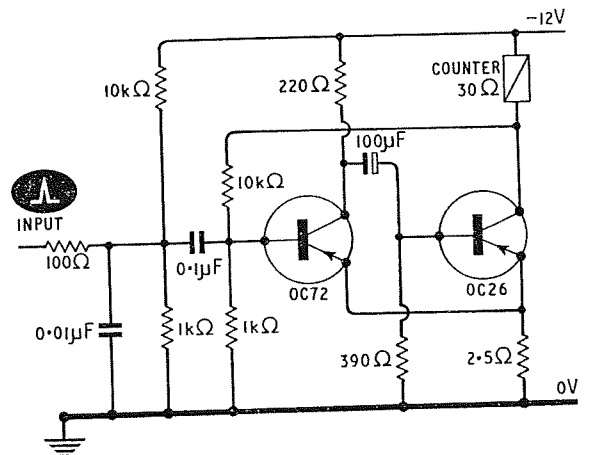

Fig. 2.7 A transistor monostable circuit

trigger the circuit and the current pulses passing through the counter will be reduced in amplitude.

A monostable transistor circuit for operating Sodeco counters is shown in Fig. 2.7⁽⁴⁾. In the quiescent state the OC26 transistor is cut off and the OC72 transistor is conducting. The circuit may be triggered by feeding a suitable positive going input pulse to it or by merely connecting the input to earth by a pair of contacts. The OC72 transistor is cut off by the pulse and the voltage across its 220 Ω collector resistor disappears, thus allowing the OC26 transistor to conduct. The double feedback

2.3 SINGLE DIGIT UNITS

system from the OC26 collector to the OC72 base and from the OC26 emitter to the OC72 emitter enables a rectangular pulse with steep sides to be obtained for the operation of the counter. The duration of the pulse may be altered by changing the value of the $100 \mu\text{F}$ capacitor or of the 390Ω resistor in the OC26 base circuit.

Thyratron tubes have been used considerably in the past for the operation of magnetic counters, but

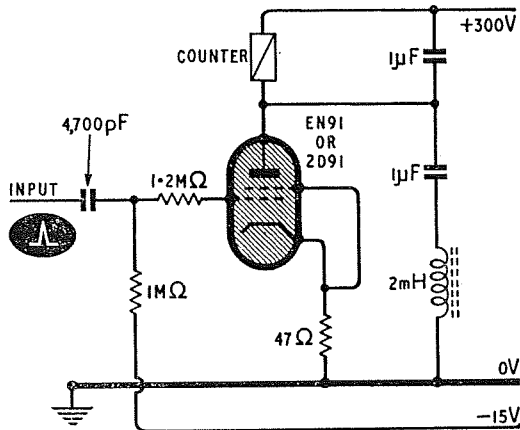

Fig. 2.8 A thyratron circuit for the operation of an electro-magnetic counter

hard valve and transistor circuits are generally more reliable since a thyratron may occasionally fail to extinguish. One type of thyratron circuit which may be used is shown in Fig. 2.8. The capacitance and inductance connected in series between the anode and earth result in the thyratron being extinguished about 50 msec after the commencement of the pulse.

It is sometimes convenient to use a valve, transistor, trigger tube or thyratron circuit to operate a small relay, the contacts of the relay being used to control the current to the counter. A small relay can be actuated by a smaller current than a magnetic counter and thus allows more latitude in the design of the driving circuit. A low power monostable circuit operating from a stabilised supply has been used to operate a relay in many scalars, a separate unstabilised supply being used to supply power to the counter through the relay contacts.

Other circuits for driving electro-magnetic counters are included in Chapter 4 (Figs. 4.37 and 4.38) and Chapter 5 (Fig. 5.21).

Sodeco single decade counting units (the 1TD series) indicate only one large digit, but are very flexible units for counting circuitry⁽⁵⁾. The single drum on

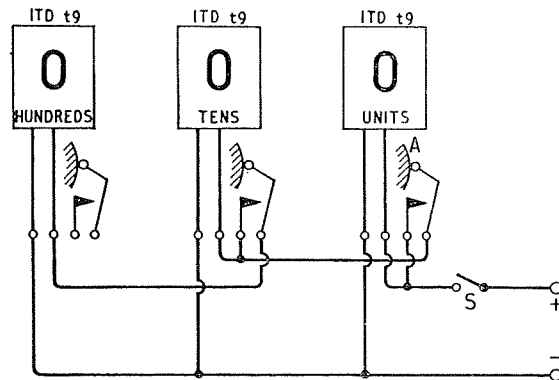

Fig. 2.9 Forward counting with single digit units

which the digits are painted revolves about a vertical axis in contrast to most other types of electro-magnetic counter. The single digit counters are designed for operation at input frequencies of up to either 10 or 25 pulses per second according to type; the slower type require input pulses of about 3 W for 40 msec and the faster type about 6 W for 20 msec. These counters are easy to read at a distance, since the digits are $7/16$ in high. Each input pulse advances the drum by half a digit, the count being completed at the end of the pulse. Any unit

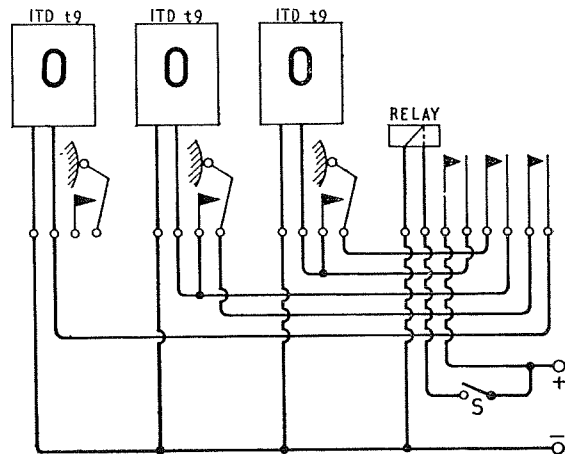
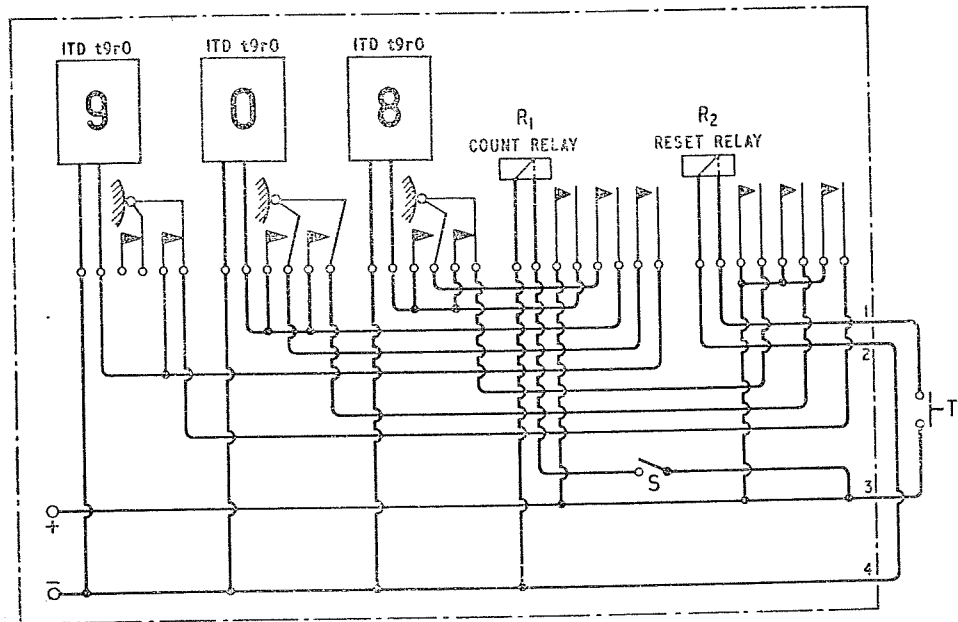
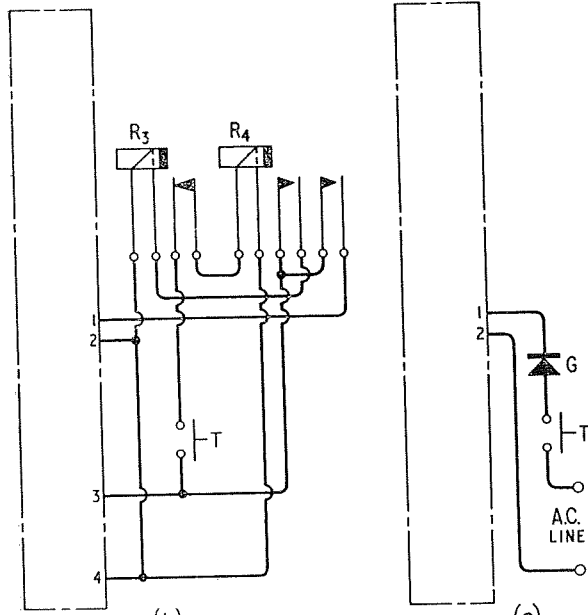

Fig. 2.10 Forward counting with constant loading of the pulse generator



(a)



(b)

(c)

Fig. 2.11 Forward counting with zero reset by means of an additional normally closed contact at position 0

which is continuously energised will, therefore, show an intermediate count.

A number of the single digit counters may be mounted adjacent to one another to indicate a number greater than nine. If they are connected as shown in Fig. 2.9, the additional contacts on the drum of the units counter (marked *A*) may be used to send a pulse to the tens counter each time the units counter moves from 9 to 0. The additional contacts on the highest decade are unused. The counters required for this circuit are coded as ITD t9; other types of single digit counters have different contacts or count backwards.

The input pulses are fed into the units decade, but each tenth pulse must not only operate this decade but also the tens decade. Each hundredth pulse must operate all three decades. If the pulses are derived from a valve or transistor amplifier (such as those already discussed), it is desirable that the amplifier should have a constant load of one decade, especially for counting at higher speeds. This can be achieved by the use of a relay as shown in Fig. 2.10.

The single decade units are not provided with any reset mechanism. They can, however, be reset

by the application of pulses to each decade in turn until the digit indicated by each is nine; one additional input pulse to the units decade will then reset the whole system to zero. Rapid resetting can, however, best be accomplished by the use of ITD t9r0 counters which have a normally closed contact which opens in position 0 in addition to the normally open contact which closes in position nine. The circuit shown in Fig. 2.11(a) is reset by pushing the button *T* a number of times until all decades are in their zero state. Each pulse advances all decades which are not indicating zero. If the button is replaced by the circuit of Fig. 2.11(b), the two relays act as a mechanical interrupter and provide the required pulses for resetting the decades automatically when the reset button is pushed once. Alternatively the resetting pulses may be obtained from the a.c. mains by adding the circuit of Fig. 2.11(c) to that of Fig. 2.11(a).

Various other circuits showing how the single decade units may be used for the transmission of numbers over a distance, addition and subtraction with forward counting decades, predetermined counting, remote predetermined counting, etc. have been published⁽⁵⁾.

REFERENCES

1. A.E. BENNETT, 'Electro-mechanical registers as used in radioactive counting systems'. *Electron. Eng.*, **23**, 81 (1951).
2. 'Dispositif pare-étincelles des compteurs d'impulsions Sodeco de la série TCe' Sodeco information sheets F27. Also: 'Untersuchung verschiedener Methoden zur Funkenlöschung bei Betrieb der Sodeco Impulszähler mit mechanischen Kontakten' Sodeco publication No. CIE 1593/1-16.
3. 'Application of Sodeco Impulse Counters in conjunction with electronic tubes', Sodeco Information Sheets E28.
4. 'The use of Sodeco impulse counters in combination with transistors', Sodeco Information Sheets E13.
5. 'Counting, transmission of numbers and impulse preselection by means of Sodeco single decade counters', Sodeco Information Sheets E44a.

Single Cathode Gas Filled Counting Tubes And Their Circuits

Counting circuits using simple cold cathode gas filled tubes can operate at rates which are at least ten times greater than that of fast electromagnetic counters. Most gas filled tubes have the property of self indication; that is, the number of counts can be read by merely observing which particular tube is glowing in each decade, no additional components being required for readout. This property of self indication also simplifies the servicing of faulty units. Cold cathode tubes are extremely reliable in operation and the absence of heaters simplifies the circuitry, reduces the power consumption and results in less heat being generated than in valve counting circuits. Cold cathode tubes are especially useful in industrial automation for many processes, including counting.

3.1 SIMPLE COLD CATHODE TUBES

Simple cold cathode tubes have two or more electrodes and are normally employed in ring circuits. They have two characteristic stable states, namely conducting and non-conducting. Any number of tubes may be employed in a ring, only one of them conducting at any one time. If the tube which indicates the digit zero is initially passing a current (and therefore glowing), the arrival of an input pulse will cause the next tube, which indicates the digit one, to glow and the zero tube to be extinguished. A second pulse applied at the input will cause the glow to be transferred to the next tube. If the last tube in the ring is glowing, the next pulse will ignite the first tube and the last tube will be extinguished. In addition an output pulse will be passed to the next ring. A counting decade may consist of a

vertical row of ten trigger tubes mounted on the front panel of the equipment, each tube being placed behind a small window on which the appropriate digit is marked. Similar decades can be placed side by side. Cold cathode binary counting stages are also used.

The multicathode tubes described in later chapters permit the use of simpler circuitry than is possible when single cathode tubes are used, but the circuits employing simple tubes are more flexible, can easily be adapted for a large variety of particular requirements and can operate from lower H.T. voltages. Cold cathode tubes are very reliable in operation. Most multicathode tubes pass a small current and the output voltage available from them is very limited. Single cathode tubes passing 25 mA or more can be used in counting equipment and fairly high output voltages can be obtained from them; such tubes can be used to operate a relay or electro-magnetic counter directly without any intermediate amplification. On the other hand some trigger tubes can be operated at low currents.

Any desired counting scale can be constructed using single cathode tubes, but this is not usually possible with multicathode tubes. Unsatisfactory operation can occur in gas filled polycathode tubes if the discharge remains at one cathode for a long time owing to sputtering of the cathode material, but trigger tube circuits do not suffer from this effect if they are properly designed.

Cold cathode tubes consist of two or more electrodes placed in a glass envelope which is filled with a suitable gas mixture, usually one or more of the inert gases at a pressure of less than one tenth of an atmosphere. If the voltage applied between the

anode and cathode of such a tube is less than a certain value, known as the striking voltage, the current which flows is very small (about 10^{-10} A) and is known as the Townsend current. When the applied voltage reaches the striking voltage, the current suddenly increases and is then usually limited only by the internal resistance of the source of applied voltage. The voltage across the tube falls from the striking voltage to a value which is known as the maintaining or running voltage. This is the normal operating voltage of the tube. Under these conditions the discharge is clearly visible, the colour being determined by the nature and pressure of the gas contained in the tube. The current flowing is given by the equation

$$I_a = \frac{V_b - V_m}{R_a}$$

where V_b is the supply voltage
 V_m is the maintaining voltage
 R_a is the resistor in series with the tube.

The maintaining voltage remains almost constant over an appreciable range of current and suitably designed cold cathode tubes can, therefore, be used as voltage stabilisers. As the cathode current rises, the discharge covers a larger area of the cathode. If the current is increased beyond the maximum permissible value, the anode to cathode potential will first rise and then fall as an overheated spot on the cathode results in thermal emission. Operation at such currents, however, will normally destroy the tube.

Once the discharge has commenced, it is necessary to reduce the voltage applied to the tube below the maintaining voltage for a time which is not less than the tube deionisation time in order to extinguish the discharge. A voltage at least equal to the striking voltage must then be applied to the tube to cause it to conduct again. If the anode voltage is reduced below the maintaining voltage for a time less than the deionisation time, the tube will ignite again when the maintaining voltage is re-applied. The deionisation time varies somewhat with the anode current and the re-applied voltage, but is normally some milliseconds.

Once a discharge has been initiated in a gas filled tube, the positive ions produced form a space

charge extending from the cathode towards the anode. This increases the voltage gradient in the cathode region and results in the maintaining voltage being considerably below the striking voltage.

The initiation of the gas discharge when a voltage is applied to any cold cathode tube is dependent on the presence of some ions in the gas. Once the discharge has commenced, the bombardment of the cathode by the positively charged ions formed in the discharge causes electrons to be emitted from the surface of the cathode and these electrons produce more ions as they pass through the gas.

The cathodes used in cold cathode tubes may be divided into two main types. The first type of cathode is coated with a material of low work function which emits electrons easily; materials with a work function of about 2.5 V such as barium or potassium are used. Tubes in which this type of cathode is used have relatively low maintaining voltages of about 60 to 100 V, but the cathodes are subject to deterioration in use. The second type of cathode has a higher work function (about 5 V) and the tubes in which they are used normally have a higher maintaining voltage. Cathodes of the second type usually consist of pure molybdenum or nickel. During the manufacture of tubes employing this type of cathode, material is sputtered from the cathode by heavy ionic bombardment so that the cathode surface is very pure. In addition the sputtered material on the glass envelope binds any impurities in the gas to the wall of the tube. Such tubes are extremely reliable when operated within their ratings, but cannot be used at low anode to cathode voltages.

3.1.1 Priming

If a discharge is to be rapidly initiated when the appropriate voltage is applied to the tube, a limited number of ions must be present in the tube at all times. A few ions per minute are formed in a trigger tube by cosmic rays and by the radiation from stray radioactive atoms which are present in all materials, but more ions are needed if the discharge must always be initiated rapidly. On the other hand, the presence of an excessive number of ions in the gas before ignition will lower the striking voltage and

affect the functioning of the tube. Artificial methods for increasing the number of ions present in cold cathode tubes are known as priming.

If a coated cathode of low work function is employed (such as in the Z701U tube), priming may take place by means of light shining on the cathode. This photoemission can occur at wavelengths less than about $5,000 \text{ \AA}$, but the glass used in the manufacture of the tubes does not cut off much of the light with a wavelength above $2,900 \text{ \AA}$. Such tubes may take a long time to ignite (up to ten minutes) if they are operated in a completely dark room and if no other form of priming is employed. Tubes which have a cathode of low work function should not be operated in bright sunlight or so many ions may be formed that the striking voltage is considerably lowered. Some tubes employing coated cathodes contain a little tritium gas or other radioactive material which provides the ionising particles required for rapid striking even in complete darkness. The amount of radioactive material used is so small that there is no danger even if the bulb of the tube is broken.

Photoemission will not occur from cathodes of the second type which have a high work function unless ultra-violet light of wavelength less than about $2,500 \text{ \AA}$ falls on them⁽¹⁾, but light of such a wavelength cannot pass through the glass of a normal tube. Such tubes are quite unaffected by bright sunlight, but some method of priming must be employed if the initiation of the discharge is to take place almost immediately after the application of a potential greater than the striking voltage.

One of the most common methods of priming involves the use of an auxiliary anode or cathode. A constant current of a few microamps flows through the gas between the auxiliary electrode and one of the other electrodes so that ions are always present in suitable numbers. If a priming cathode is used, the tube can be extinguished by raising the cathode potential without the priming discharge being affected, but a negative supply line is required. Tubes with a priming anode can be extinguished by lowering the main anode voltage without the priming discharge being affected. In some tubes a priming anode and a priming cathode are used, the auxiliary discharge taking place between these

two electrodes. The ionisation time is affected by the magnitude of the priming current, but the maintaining voltage is independent of this current. Primed tubes which use pure metal cathodes have a very constant striking potential and are unaffected by the ambient lighting.

3.2 COLD CATHODE DIODE COUNTING CIRCUITS

One of the simplest cold cathode diode circuits is shown in Fig. 3.1⁽²⁾. Let us assume that the left-hand tube, V_1 , is conducting and the right-hand tube, V_2 , is cut off. The voltage developed across R_1 (due to the current flowing through this resistor to V_1) is such that the voltage across V_2 is less than the striking voltage of this tube. Thus the system is stable. The capacitor C_2 is charged so that the anode of V_2 is positive with respect to the anode of V_1 by an amount equal to the potential difference across R_2 .

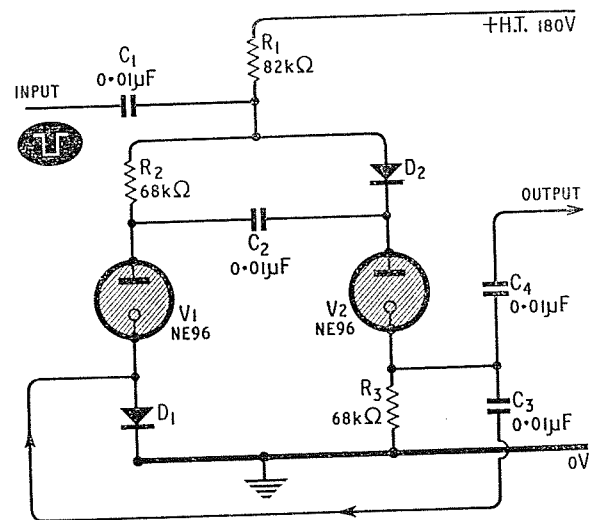

Fig. 3.1 A simple binary counter using cold cathode diodes

If a negative going pulse is now applied at the input, the anode voltage of V_1 falls below the maintaining voltage and the tube is extinguished. The current through R_1 , therefore, decreases and the anode voltages of both tubes will tend to rise. In addition, a sudden rise of anode voltage will occur at

SINGLE CATHODE GAS FILLED TUBES AND THEIR CIRCUITS

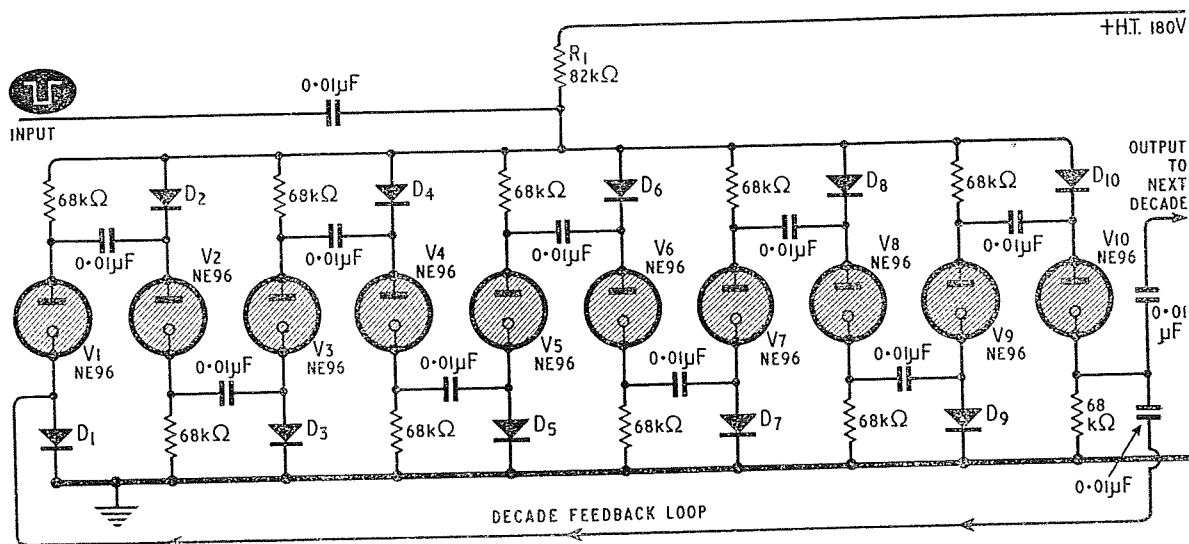

Fig. 3.2 A ring of ten cold cathode diodes for decade counting

the end of the input pulse. C_2 is prevented from discharging rapidly by the reverse resistance of D_2 and, therefore, it holds the anode of V_2 at a positive potential with respect to the anode of V_1 . V_2 will, therefore, strike preferentially to V_1 as the anode voltage rises. When V_2 commences to conduct, the voltage across V_1 is kept below the striking voltage by the voltage drop across R_1 . The glow is thus transferred from V_1 to V_2 and a count is registered.

When V_2 is conducting, no current flows through R_2 and hence the voltage across C_2 equals the voltage across the diode D_2 — which is small, since the current passes through this diode in the forward or low resistance direction. The capacitor C_3 is charged owing to the flow of current through R_3 . The polarity of this charge is such that the cathode of V_1 is negative with respect to the cathode of V_2 . If a second negative going pulse is now applied at the input, the anode voltages are reduced as before and V_2 is extinguished. C_3 is prevented from discharging quickly by the high reverse resistance of D_1 and, therefore, the cathode of V_1 is held at a negative potential with respect to the cathode of V_2 . V_1 will, therefore, strike preferentially to V_2 , as the anode to cathode voltage is greater. The second pulse thus resets the binary circuit to its initial or zero state in which V_1 is glowing. The capacitors C_2 and C_3 must be large enough to hold most of

their charge during the switching operation, but should not be so large that the maximum counting speed is appreciably reduced.

A number of binary circuits can be cascaded as discussed in Chapter 1 but, when cold cathode tubes are used, it is normally much more convenient to construct a ring counter such as that shown in Fig. 3.2. One common anode resistor, R_1 , is employed and the coupling capacitors are placed alternately in between the cathodes and anodes of successive stages as shown. The principle of operation of this circuit is exactly the same as that of Fig. 3.1, but there are ten tubes in the ring instead of two. Any even number of tubes, however, could be used in the ring.

If V_{10} is glowing when an input pulse is received, a positive going output pulse will be produced which may be used to operate a ring of ten similar tubes, in which case the arrangement will count up to one hundred. Alternatively the output pulses (after amplification and phase inversion) may be used to operate an electro-magnetic counter.

If the position of the coupling capacitors are altered in Fig. 3.2 so that there is cathode coupling between V_1 and V_2 , anode coupling between V_2 and V_3 , cathode coupling between V_3 and V_4 , etc., the circuit will count backwards as the glow is transferred from the right-hand tube in the circuit towards the left-hand tube.

ELECTRONIC COUNTING CIRCUITS

A very similar cold cathode diode ring circuit is shown in Fig. 3.3 in which all of the capacitors are placed in the cathode circuits of the tubes. Any number of tubes may be used in this type of circuit. When V_1 is conducting, the right-hand side of C_2

cathode, it possesses at least one additional electrode known as the trigger or starter. This electrode may normally be considered as an additional anode, although in a few tubes (such as the Z804U) the trigger has a negative potential and acts as an

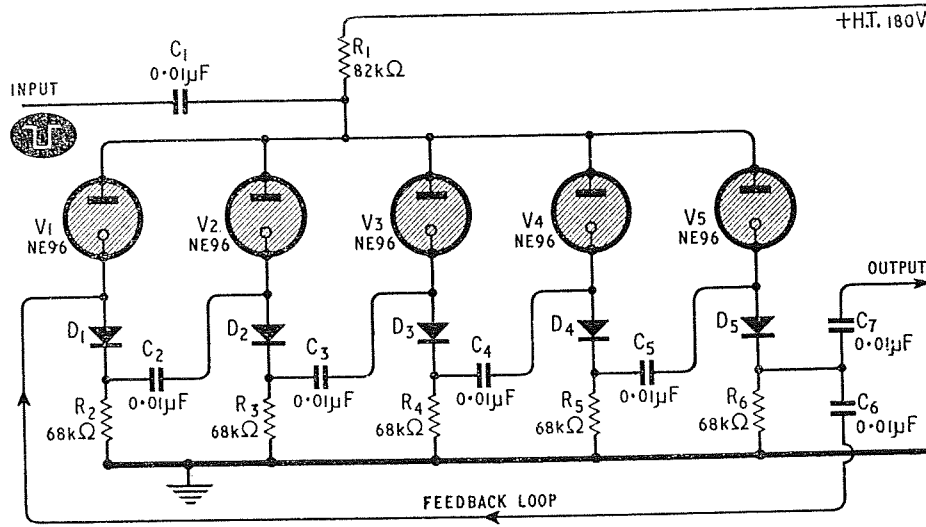

Fig. 3.3 A ring of five diodes with cathode coupling

is negative with respect to its left-hand side. If a negative going pulse is now applied to all of the anodes, V_1 is extinguished and the junction of D_1 and R_2 becomes more negative as the current through R_2 declines. C_2 cannot discharge rapidly through the high reverse resistance of the diode D_2 and the negative pulse from the junction of D_1 and R_2 is applied to the cathode of V_2 . This results in V_2 striking preferentially to other tubes when the common anode voltage rises at the end of the input pulse.

Cold cathode diodes are not used as counting elements in modern equipment, since similar circuits can be constructed using the more versatile trigger tubes or PNP semiconductor devices. The maximum speed of cold cathode diode ring circuits is usually of the order of 1 kc/s. Changes in the striking voltage of the diodes during life tends to reduce reliability and the amplitude and duration of the input pulses are quite critical.

3.3 TRIGGER TUBES

A trigger or relay tube is very similar to a cold cathode diode but, in addition to the anode and

additional cathode. The trigger is normally placed near to the cathode and either in or near to the main anode to cathode gap. The voltage which must be applied to the trigger electrode to initiate a discharge is much less than that required by the main anode. In normal operation the potential applied between the main anode and the cathode of a trigger tube is less than the striking voltage but is greater than the maintaining voltage of the tube. If a suitable positive pulse is applied to the trigger electrode, a current will flow between this electrode and the cathode and the gas between the electrodes will be ionised. Enough ions will be formed for the striking voltage of the main gap to be lowered almost to the maintaining voltage. The greater the trigger current, the greater the amount by which the striking voltage is lowered. Thus the trigger pulse can initiate conduction in the main anode to cathode gap and it can be said that the discharge has been transferred from the trigger gap to the main gap. For a given value of anode-cathode voltage, a certain minimum trigger current is required to enable the main gap to take over the discharge. This is known as the transfer current.

Once the main gap has commenced to conduct, the tube can be extinguished only by reducing the potential between the main anode and cathode below the maintaining voltage of the tube for a time which is not less than the deionisation time. No alteration of the trigger voltage will extinguish a discharge in the main gap; the action of the trigger electrode is not reversible in the way that the grid of a normal thermionic valve can reversibly control the anode current of the valve.

3.3.1 Trigger Tube Characteristics

The discharge in a trigger tube may be initiated between any two of the three electrodes and may

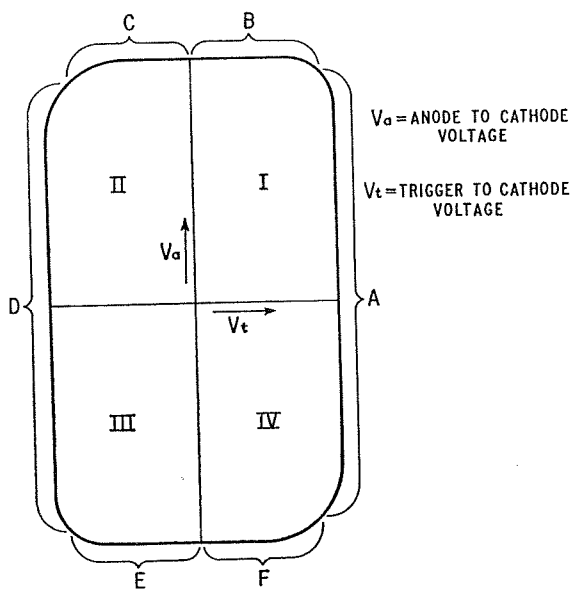

Fig. 3.4 Breakdown characteristics of a trigger tube

flow in either direction, although some of these modes of operation will damage the tube. The breakdown characteristic of a tube which is initially non-conducting can be conveniently represented by the type of quadrant diagram shown in Fig. 3.4. No discharge will take place in the tube if the anode and trigger voltages measured with respect to the cathode can be represented by a point inside the curve unless the operating point has previously been outside the curve and the discharge has

not since been extinguished. At certain points within the loop the discharge can be maintained but not initiated. Owing to the spread of the characteristics from tube to tube, it is necessary to draw two curves one inside the other in the tube data sheets. If the operating point is taken outside the outer curve, a discharge will take place in all tubes to which the curves apply, but no discharge can be initiated in any tube by applying a potential which can be represented by a point inside the inner loop. At operating points between the two loops, some tubes will strike whilst others will not.

If the trigger potential is increased at a small anode potential in Fig. 3.4, the loop will be crossed in the region marked *A*; a discharge then commences between the trigger and cathode. It should be noted that the trigger striking potential is almost independent of the anode potential. If the anode voltage of a trigger tube is increased so that the operating point cuts part *B* of the curve, however, a discharge will be initiated between the anode and cathode. In section *C* of the curve the discharge is from anode to trigger, whereas in section *D* it is from cathode to trigger. If the anode is at an appreciable negative potential, it can also act as a cathode. In section *E* of the curve the discharge is from the cathode to anode and in section *F* from the trigger to anode.

Almost all trigger tubes are designed for operation with positive anode and trigger potentials. The operating point should, therefore, be within quadrant I of Fig. 3.4 before ignition takes place. After ignition has occurred, the operating point will return to a point well inside quadrant I owing to the voltage drop in the anode and trigger resistors. A few trigger tubes (such as the Z804U) operate in quadrant II with the trigger negative with respect to the cathode. No tubes should be operated so that the curve is crossed in quadrants III or IV or they may be damaged.

The characteristics of a trigger tube are affected by a thermal hysteresis effect when the tube has been passing a fairly high anode or trigger current for a short time. The characteristic may be changed by as much as 30 V when a tube has been passing its maximum rated anode current for about one minute.

ELECTRONIC COUNTING CIRCUITS

The ionisation time of a trigger tube may be defined as the interval between the application of a pulse to the trigger electrode and the flow of the full anode current. It is the sum of the following three times:

1. *The Statistical Delay.* This is the average delay between the application of the trigger pulse and the time when an ionising particle enters the trigger to cathode gap and initiates the discharge. It depends on the method of priming and the amount by which the trigger potential exceeds the minimum trigger striking voltage.
2. *The Formative Delay.* This is the time taken for the trigger to cathode discharge to be established. It is dependent on the amount by which the trigger potential exceeds the minimum trigger striking voltage.
3. *The Transition Time.* This is the time taken for the trigger discharge to ionise the main gap so that a large anode current can flow. This time is inversely proportional to the trigger current and the anode voltage. The total ionisation time may vary between about 20 μ sec and 10 msec according to the type of tube and the applied potentials.

The ionisation and deionisation times of trigger tubes limit the maximum frequency at which trigger tube counting circuits can be operated.

3.3.2 Trigger Tetrodes

Trigger tetrodes have two independent trigger electrodes instead of one. A suitable voltage applied to either of the trigger electrodes will initiate conduction. Such tubes can be used in circuits which will count in either direction.

The basic characteristics of trigger tubes are discussed in more detail in various publications⁽³⁻⁷⁾, whilst the fundamentals of electrical discharges in gases are discussed in the book by Penning⁽⁸⁾.

3.4 TRIGGER TUBE COUNTING CIRCUITS

All trigger tube counting circuits must employ components in the trigger circuits which will cause the

tubes to strike under the combined influence of the input pulse and the bias voltage from the previous conducting stage. In addition some means of extinguishing each tube must be included. There are three types of coupling circuit which have been used to extinguish a glowing tube in a counting circuit when the succeeding tube has ignited. In one type of circuit separate anode resistors are employed with a coupling capacitor between the anodes. If a non-conducting tube ignites, its anode becomes more negative and this negative pulse is fed through the capacitor to the anode of the tube which was initially conducting. The pulse extinguishes this tube. A second type of circuit employs separate cathode resistors, but no anode resistors; the extinguishing capacitor is connected between the cathodes. This type of circuit is exactly the same in principle as the first type, except that cathode coupling is employed.

The third type of extinguishing circuit uses a common anode resistor for two or more tubes. The cathode of each tube is returned separately to the H.T. negative line via a resistor in parallel with a capacitor. If the non-conducting tube strikes, the increased voltage drop across the common anode resistor causes the tube which was initially conducting to be extinguished. This type of coupling is most commonly employed, since the positive voltage at the cathode of the conducting tube can conveniently be used for biasing the succeeding tube. The circuit does, however, require a fairly high value of H.T. supply, since both anode and cathode resistors are used.

3.4.1 Practical Binary Circuits

One of the simplest binary or ring of two counting circuits using trigger tubes is shown in Fig. 3.5⁽⁹⁾. It uses two subminiature Hivac XC18 trigger tubes with common anode resistor coupling. R_1 , R_2 and R_4 provide a positive bias for the trigger electrode of V_1 and R_9 and R_{10} provide the bias for V_2 . This bias voltage is not great enough to cause ignition of the tubes by itself but it enables an input pulse of much smaller amplitude to be used to ignite the tubes than if no bias were provided.

When the H.T. supply voltage is first applied to the circuit, a pulse is applied to the trigger of V_1

SINGLE CATHODE GAS FILLED TUBES AND THEIR CIRCUITS

via C_1 , R_2 and R_3 . C_1 presents a much lower impedance to the pulse than R_1 and, therefore, the trigger electrode of V_1 will become momentarily more positive than its normal working voltage (which is not reached until C_1 is fully charged). This positive pulse ignites V_1 which indicates zero counts.

If a positive pulse of suitable amplitude and duration is now applied at the input, it is conveyed to

numbers greater than one can be counted. The cathode voltages of the tubes in the circuit of Fig. 3.5 change only relatively slowly owing to the effects of the capacitors C_3 and C_4 and it is, therefore, not possible to obtain a steeply rising output pulse.

If, however, the circuit of Fig. 3.5 is modified to that of Fig. 3.6, suitable output pulses can be ob-

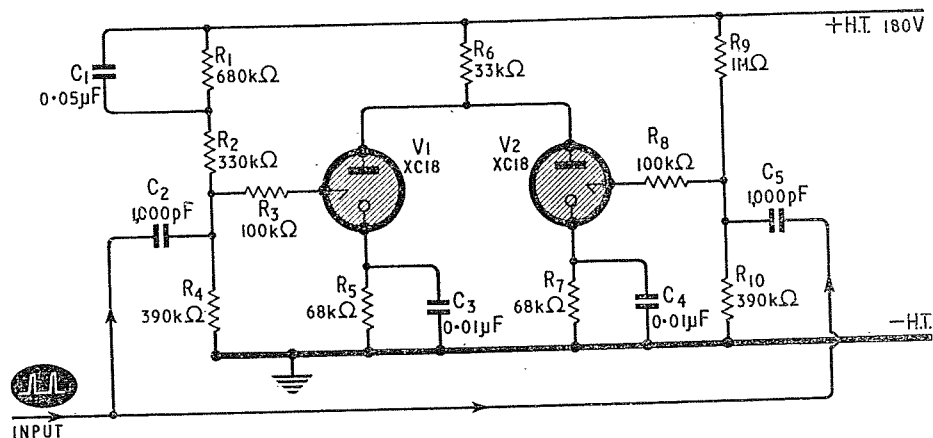

Fig. 3.5 A simple binary counter using XC18 trigger tubes

both trigger electrodes via C_2R_3 and C_5R_8 respectively. The pulse causes V_2 to ignite, but leaves V_1 (which is already passing a current) momentarily unchanged. C_4 is initially uncharged and, therefore, V_2 takes a current which reduces the common anode potential to the maintaining voltage of this tube. C_3 has charged whilst V_1 was conducting and maintains the cathode of V_1 at a positive potential. The potential across this tube is, therefore, less than the maintaining voltage and it is extinguished. Thus the discharge has been transferred from V_1 to V_2 and a count has been registered. A second similar pulse at the input will cause the discharge to return to V_1 by exactly the same mechanism, since the circuit is symmetrical with respect to V_1 and V_2 , except for the presence of the starter capacitor C_1 in the trigger circuit of V_1 . On the binary scale, V_1 indicates the digit zero and V_2 indicates the digit one. The quiescent potential of a conducting cathode is about +70 V.

A binary circuit will normally be required to provide a steeply rising output pulse which can operate a succeeding binary counting stage so that

tained for the operation of a succeeding binary counting stage⁽⁹⁾. The circuit of Fig. 3.6 is basically the same as that of Fig. 3.5 except that it is designed to provide a fast rising output pulse of about 30 V amplitude from the cathode of V_1 each time this tube ignites. A negative pulse is also formed each time V_1 is extinguished, but a pulse of this polarity will not ignite a trigger tube in a succeeding binary counting circuit.

The Hivac XC23 tube can pass a much larger current than the XC18 tube. If a pair of XC23 tubes are used in the circuit of Fig. 3.6 and the component values are suitably adjusted, the circuit can be used to operate a relay at every alternate input pulse⁽⁹⁾.

Although binary circuits require fewer trigger tubes to count over a certain scale than ring circuits, the latter are usually preferred because they provide decade readout. It is possible to construct binary scales of ten employing five trigger tubes per decade. It is interesting to note that some of the earliest trigger tube counting circuits employed transformer interstage coupling.

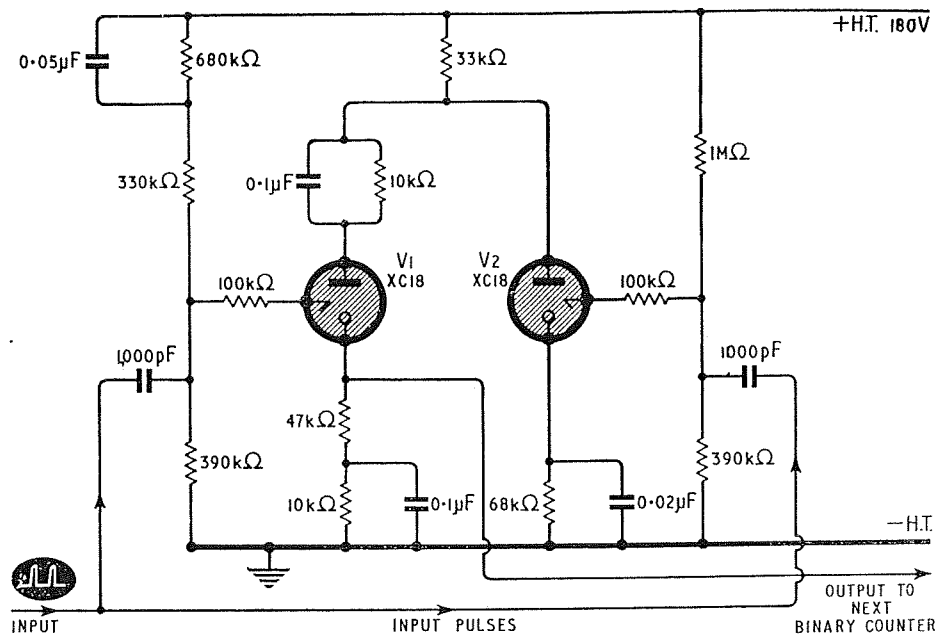

Fig. 3.6 A simple binary counter which output provides output pulses for a succeeding stage

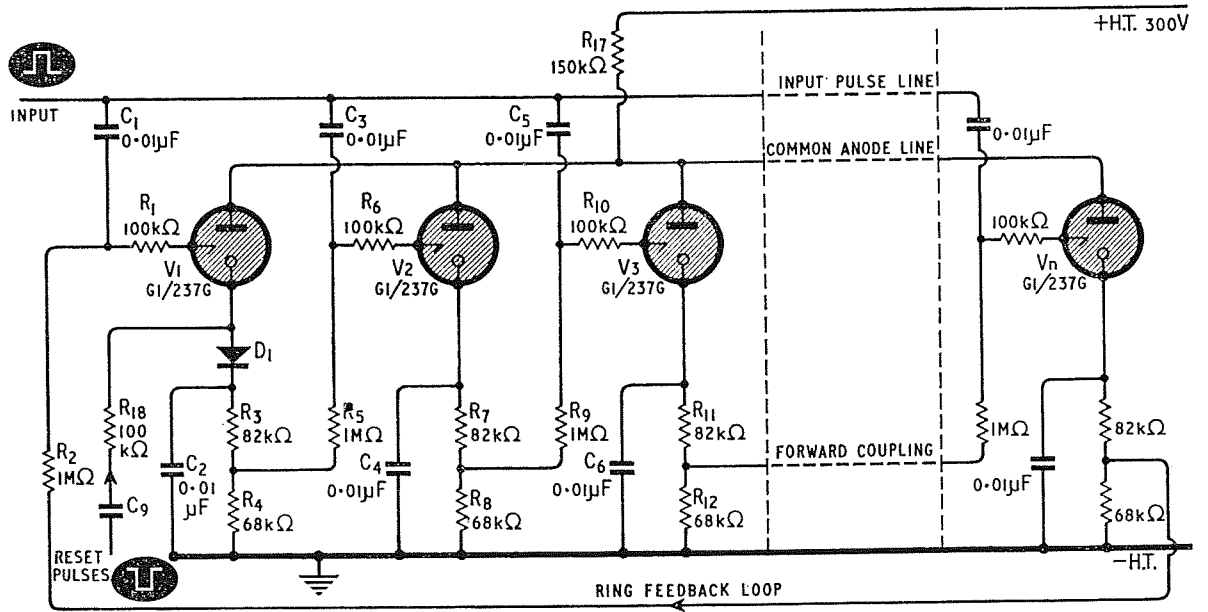

Fig. 3.7 A ring counter using G1/237G tubes

3.4.2 Trigger Tube Ring Counters

A typical example of a trigger tube ring counting circuit is shown in Fig. 3.7 using the S.T.C. G1/237G subminiature trigger tubes⁽¹⁰⁾. Any number of additional stages may be inserted between the two dotted lines, but rings of ten are most common. At any one time only one of the tubes in each ring is conducting. Each positive going input pulse (of amplitude between 50 and 60 V) is applied via capacitors and resistors to the trigger electrodes of all the tubes in the ring. The amplitude of the input pulses alone must not be great enough to trigger the tubes into the conducting state.

If at any time V_2 is conducting, a voltage will be present across R_7 and R_8 . This voltage will be held fairly constant for a short time by the charge stored in C_4 if the current passing through V_2 changes. No current is passing through the other tubes and, therefore, the remaining cathode capacitors, C_2 , C_6 , etc. are uncharged. The voltage across R_8 is applied via R_9 and R_{10} to the trigger electrode of V_3 . When a positive pulse of a suitable amplitude is applied at the input, the trigger of V_3 will already be more positive than any of the other trigger electrodes by an amount equal to the voltage drop across R_8 . Therefore V_3 ignites, but the other tubes are unaffected by the input pulse.

The capacitor C_6 is uncharged at the instant V_3 ignites and, therefore, the common anode potential will be reduced to a value equal to the maintaining voltage of V_3 above earth potential. The cathode of V_2 is held at a positive potential for a short time by the charge of C_4 . The anode to cathode voltage of V_2 is, therefore, less than the maintaining voltage of this tube which is thus extinguished. The cathode potential of V_3 rises exponentially as C_6 charges. The anode voltage of this tube will, therefore, also rise exponentially with the same time constant so that the potential across V_3 remains constant at the maintaining voltage.

The discharge thus passes from V_2 to V_3 . In exactly the same way it can be made to pass from V_3 to the following tube (which is not shown in Fig. 3.7) and hence forward around the ring at one step for each input pulse. The circuits of Figs. 3.8 to 3.13 inclusive all operate on the same basic principle.

If a negative going resetting pulse of at least 100 V in amplitude is applied to C_9 of Fig. 3.7, the cathode of V_1 will become momentarily more negative and the extra voltage appearing across this tube will cause it to ignite. The tube which was previously conducting is extinguished by the same process as in normal counting. The pulse voltage biases the diode D_1 in the high resistance direction and the pulse is not by-passed to earth by C_2 . If D_1 were omitted, C_2 would prevent the pulse from causing any rapid change in the potential of the cathode of V_1 .

An H.T. supply potential of about 300 V is suitable for the circuit of Fig. 3.7, but if a higher potential is used R_{17} may be increased by about 1,000 Ω for each volt of H.T. above 300 V. The anode current (about 1 mA) will then be unaffected.

The G1/238G can also be used in the circuit of Fig. 3.7; it is a very similar tube to the G1/237G, but the tolerances are somewhat greater. These tubes may not operate satisfactorily if the ambient illumination is less than about 2 ft-candles (20 lx). They should be mounted by means of a metal clip located at about the centre of the tube and connected to the trigger electrode.

If separate anode resistors are used for each tube in this type of circuit instead of the common anode resistor, the tubes will still strike successively, but no tube will be extinguished until the anode supply voltage is reduced by an extinguishing pulse.

3.4.3 Z700U and Z700W counters

The circuit of Fig. 3.8 shows a chain counter employing the Mullard Z700U (equivalent to the Philips Z70U) or Z700W (equivalent to the Philips Z70W) primed trigger tubes^(5, 6, 11). The components shown by the dotted lines are employed only when a reversible counter is required; the Z700W tube which has two trigger electrodes should then be used. The characteristics of the Z700U and the Z700W are virtually identical except for the fact that the Z700W has two trigger electrodes and a rather higher transfer current. The chain counter of Fig. 3.8 can be closed by a feedback loop to form a ring circuit. Two feedback loops are required in reversible ring counting circuits (as in Fig. 3.10).

ELECTRONIC COUNTING CIRCUITS

Both the Z700U and the Z700W have priming cathodes to ensure reliable ignition even in complete darkness. This electrode is connected to the H.T. negative line via an $18\text{ M}\Omega$ resistor. In normal operation a current of about $3\mu\text{A}$ should pass through this resistor no matter whether the main gap is conducting or non-conducting.

In Fig. 3.8 single cathode resistors are used so that the whole of the cathode voltage of any stage is applied to the trigger electrode of the next stage. Otherwise the operation of the circuit is the same

tube shown in Fig. 3.8. The anodes and also the cathodes of each pair of Z700U tubes are connected together. The circuit is unchanged except that the two trigger electrodes of each stage are present in separate tubes. A count is indicated by a stage when either of the two tubes is glowing.

The maximum operating frequency of Z700U and Z700W circuits is 2 kc/s to 5 kc/s, depending on the component tolerances and the stability of the supply voltage. The amplitude of the input pulses should be 100 V and the duration about $20\ \mu\text{sec}$. The

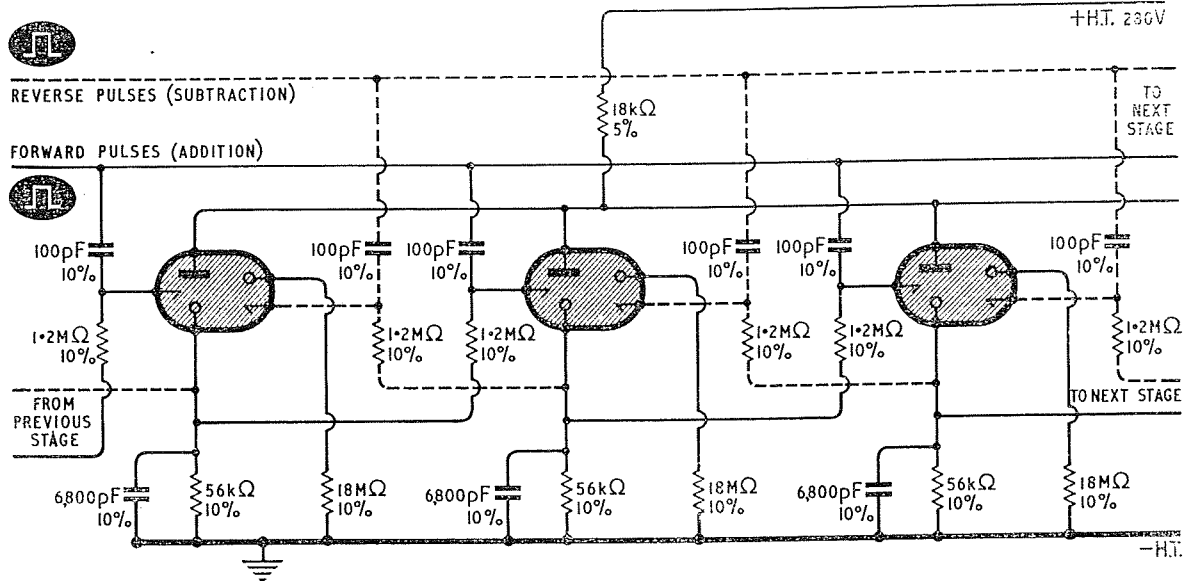

Fig. 3.8 A chain counter using Z700U trigger tubes. A reversible counter can be constructed if Z700W tubes are used with the additional components shown dotted

as that of the circuit of Fig. 3.7. The cathode current of the conducting Z700U or Z700W tube should be between 2 and 4 mA.

If the additional components shown by the dotted lines of Fig. 3.8 are used with Z700W tubes, it can be seen that the circuit is symmetrical with respect to the forward and reverse directions. Suitable pulses applied to the forward input line will cause the circuit to count in the forward direction, whilst similar pulses applied to the reverse input line will cause the glow to be transferred in the opposite direction. Forward and reverse pulses should not be applied simultaneously.

It is also possible to construct a reversible counter by using one pair of Z700U tubes for each Z700W

maximum counting speed is attained with an H.T. supply potential of 300 V, with a common anode resistor of $27\text{ k}\Omega \pm 5\%$ and with $4,700\text{ pF} \pm 10\%$ cathode capacitors. The supply voltage must not exceed 310 V.

A similar circuit employing a common cathode resistor instead of a common anode resistor has been published⁽⁶⁾. Details of a biquinary decade counter which employs a ring of five combined with a ring of two are also available⁽⁶⁾.

3.4.4 Z701U Counters

The Z701U is a subminiature low voltage trigger tube equivalent to the Z71U. It can be used in the

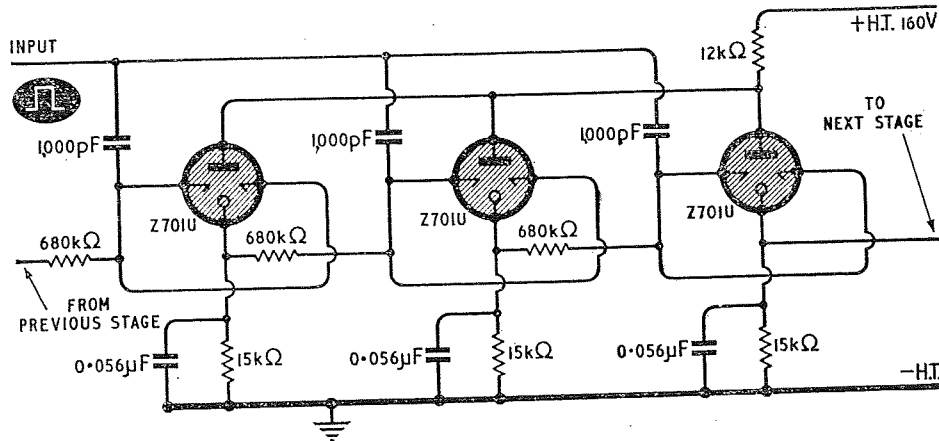

Fig. 3.9 A chain counter using low voltage tubes

circuit of Fig. 3.9 for forward counting^(5, 11) and can also be used for reversible counting by employing the techniques shown in Fig. 3.8 with the circuit values of Fig. 3.9. The H.T. supply potential required (160 V) is lower than that required by most similar circuits. The input pulse should be of 60 V amplitude and about 25 μ sec in duration. The cathode current of the conducting tube should be between about 3 and 7 mA. The Z701U should not be operated in total darkness, since photoemission is the only form of priming. The maximum frequency of operation of the circuit of Fig. 3.9 is about 2 kc/s.

3.4.5 GPE175M Bidirectional Counter

Fig. 3.10 shows a two decade reversible ring counter using Ericsson GPE175M tubes^(12, 13). For simplicity only two stages are shown in each ring, the other stages being identical with those shown. The two GTE175M tubes are used to couple the two decades. The GPE175M has two trigger electrodes and a priming cathode. The maximum counting speed of the circuit shown is about 650 pulses per second and the recommended operating current of the tubes is 2.5 mA. This is, therefore, the quiescent current for each decade.

The trigger electrodes are clamped by means of semiconductor diodes to prevent their potential from falling below +100 V; this is necessary to prevent the triggers from acting as cathodes. The input pulses tend to bias the diodes in the high

resistance direction and are, therefore, not short circuited by them. In addition to the +100 V supply, a -100 V supply is required for the auxiliary priming cathodes of the tubes.

If V9 is conducting and a forward pulse is received, both V0 and V10 will be triggered simultaneously, since their trigger electrodes receive both the bias voltage from the cathode of V9 and also the forward input pulses. V0 remains glowing and V9 is extinguished by the process discussed previously for the circuit of Fig. 3.7. As V10 ignites, it provides a pulse from its cathode which is fed to the forward pulse line of the next decade. The count in the second decade is, therefore, advanced by one. A capacitor is connected from the anode of V10 to earth. When this tube is triggered the charge of the capacitor quickly passes through the tube giving a sharp pulse. The high value of the anode resistor results in the circuit being self extinguishing.

If V0 is glowing, a positive bias is applied to the trigger electrode of V11 and also to the right-hand trigger of V9 which is used for reverse counting. If a pulse is now applied to the reverse input of the first decade, it is fed to both V9 and V11 and ignites these tubes. The ignition of V9 causes V0 to be extinguished, since these tubes are in the same ring. V9 remains glowing, but V11 feeds a pulse to the reverse pulse line of the next decade and then extinguishes itself. The second decade is now indicating one count (that is ten pulses) less than it did previously whilst the first decade indicates nine instead of zero. Thus the pulse applied to the reverse line

ELECTRONIC COUNTING CIRCUITS

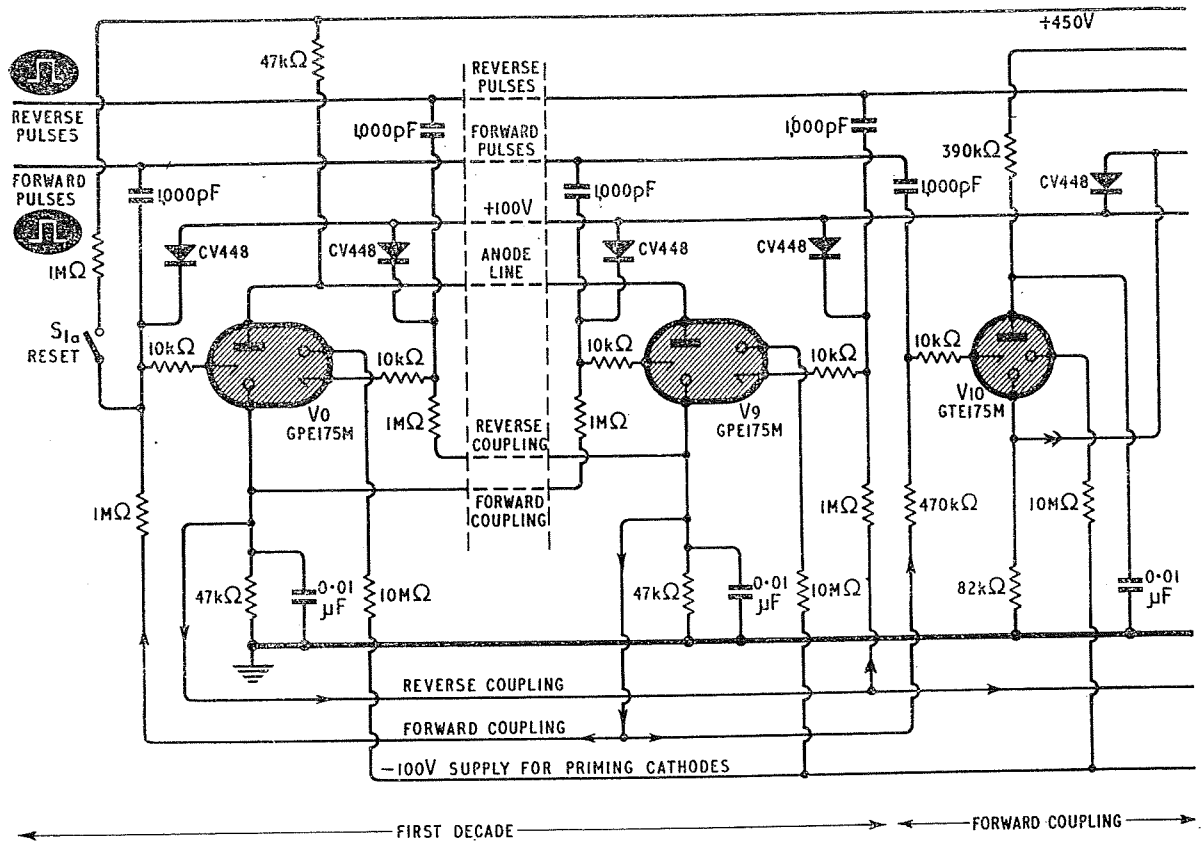

Fig. 3.10 A two decade

has caused the total count, therefore, to be reduced by unity.

The input pulses applied to the circuit of Fig. 3.10 should be of 85 to 95 V in amplitude and about 200 μ sec in duration.

Tubes with only one trigger electrode can be used in the coupling circuit. Two GTE175M tubes (Ericsson) which have one trigger electrode each may be used. Alternatively two GPE175M tubes may be used with the two trigger electrodes of each tube connected together; the whole circuit can then be designed using only the one type of tube.

If the reset switches S_{1a} and S_{1b} are momentarily closed, positive pulses will be applied to the trigger electrodes of V0 and V12. These tubes will, therefore, be ignited and the tubes which were glowing previously will be extinguished by the same processes as in normal counting. Thus both decades are returned to zero. S_{1a} and S_{1b} would normally be ganged together.

Another very similar bidirectional counting circuit using XC24 (Hivac) tubes for decade counting and XC18 tubes in the coupling circuits between decades has been published⁽⁹⁾. The Z700W bidirectional counter of Fig. 3.8 can also be adapted for multi-decade counting if the necessary coupling circuits are added.

3.4.6 ER3 Ring Counter

The ER3 trigger tube (Elesta) may be used in the reversible ring counting circuit shown in Fig. 3.11⁽¹⁴⁾. Two trigger electrodes are provided and also an auxiliary priming anode. The type ER1 tube has similar electrical characteristics to the ER3 tube, but possesses only one trigger electrode and has no priming anode. It is, therefore, somewhat slower than the ER3 and cannot be used in reversible counters unless two ER1 tubes are used in each stage. The circuit values for ring counters using the

SINGLE CATHODE GAS FILLED TUBES AND THEIR CIRCUITS

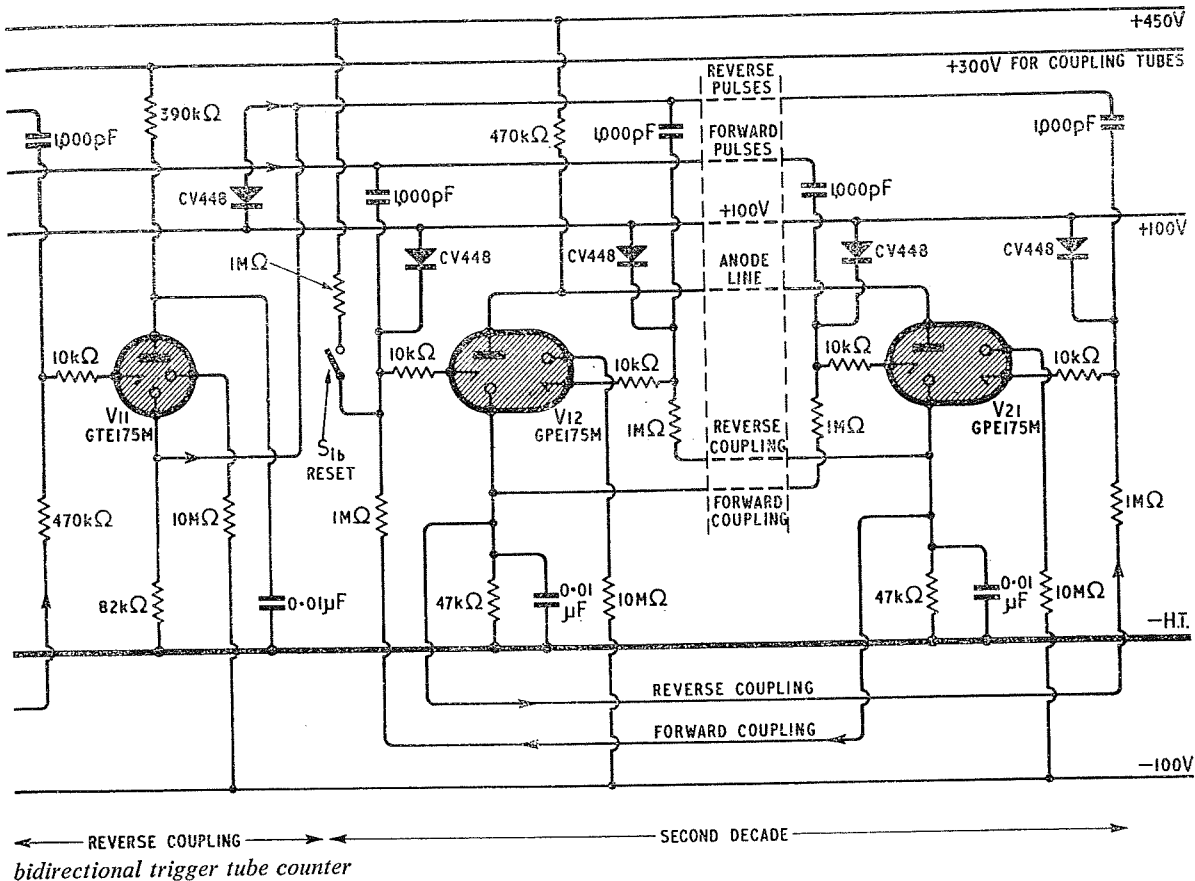

ER1 should be similar to those of Fig. 3.11.

The maximum counting rate of the ER3 circuit increases somewhat with the number of tubes in the ring, but the maximum possible rate is of the order of 2,000 pulses per second. The use of rectangular shaped input pulses of about 120 V in amplitude and 20 μsec duration is important if the maximum counting speed is to be attained. The current taken by the circuit is about 15 mA.

3.4.7 Digital Readout from Trigger Tube Circuits

Although trigger tubes are inherently self indicating, it is usually much more convenient to use one digital indicator tube per decade to display the state of the count than to observe the ten trigger tubes in each decade themselves. The indicator tubes display one digit each as a neon glow. They have one common anode and the current passes from this to any one of ten cathodes. Each of the cathodes has the

shape of one digit. One cathode is covered by a red glow when the tube is operating. Further details of digital indicator tubes are given in Chapter 10.

The digit which is being displayed at any specified time is determined by which cathode is passing current at that time. The selection of this cathode is carried out by the counting circuit itself. Each trigger tube in the decade circuit is connected to one of the ten indicator tube cathodes. When a particular trigger tube is conducting, the circuit must be arranged so that the corresponding cathode of the indicator tube is at a lower potential than that of the other indicator tube cathodes. The tube then indicates the appropriate number corresponding to the number of the trigger tube in the ring.

A typical circuit is shown in Fig. 3.12; it uses Z700U trigger tubes and the Z520M numerical indicator tube (Mullard)⁽¹⁵⁾.

The Z700U trigger tube V10 in the input circuit of Fig. 3.12 converts any incoming pulses into pulses

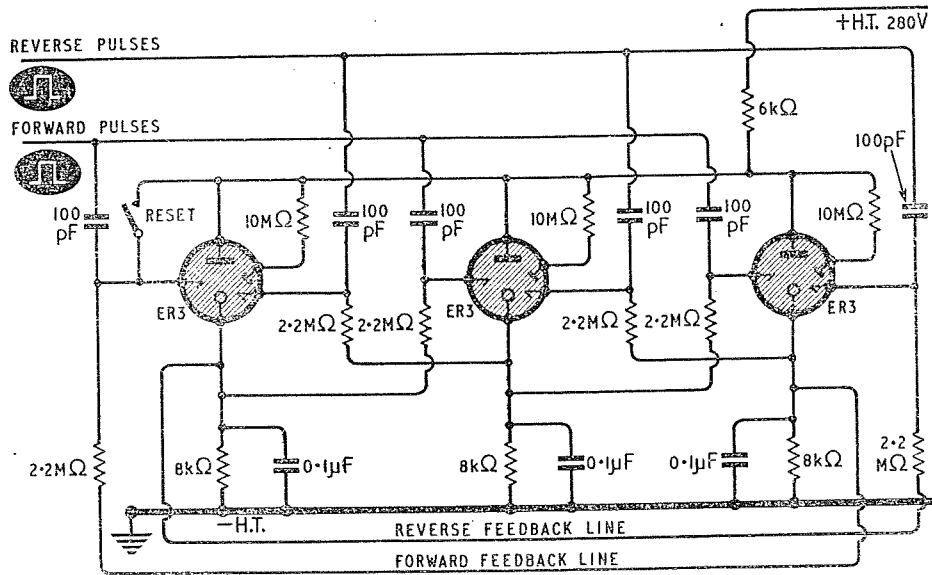

Fig. 3.11 A reversible chain counter using ER3 tubes

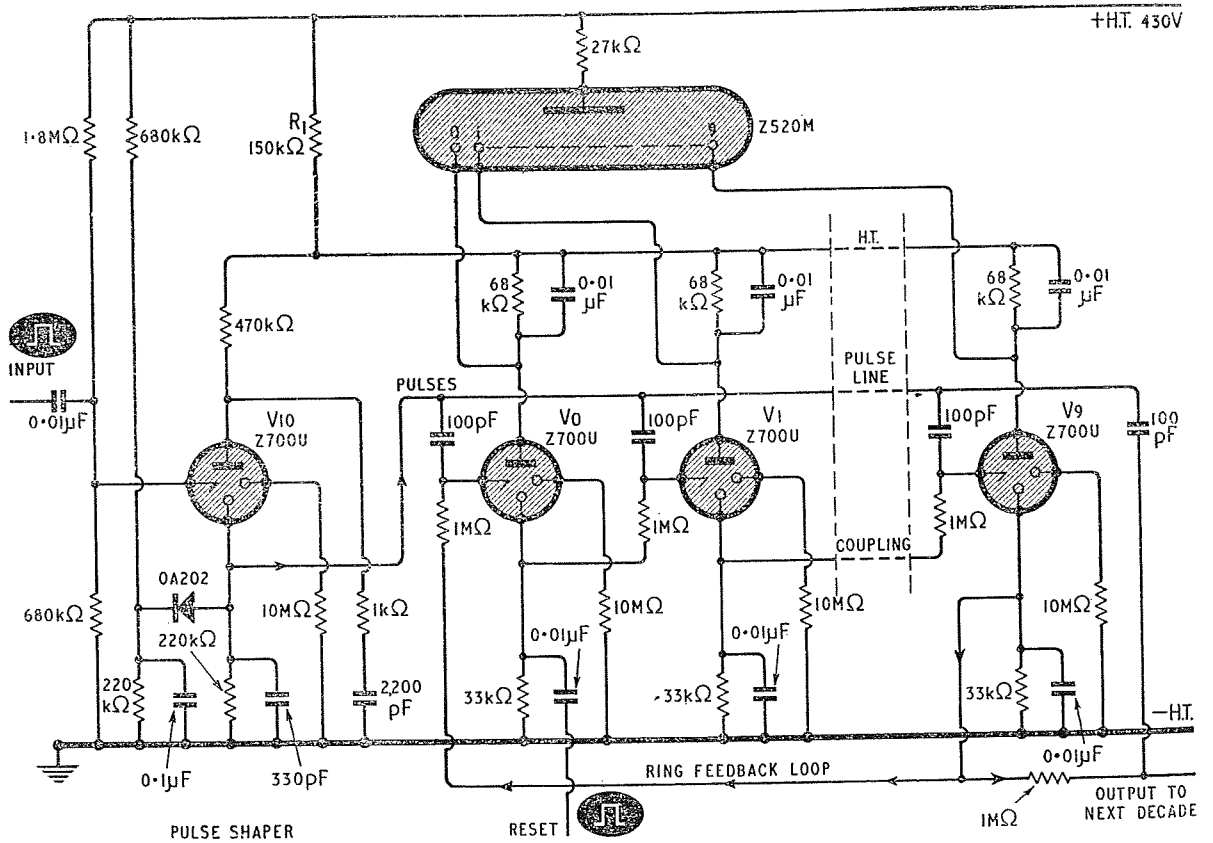

Fig. 3.12 A Z700U decade counter with Z520M readout

SINGLE CATHODE GAS FILLED TUBES AND THEIR CIRCUITS

of a suitable amplitude and duration for the operation of the other ten Z700U tubes which perform the counting operation. Pulses from the cathode of V10 are fed along the pulse line to the trigger electrodes of the counting tubes via 100 pF capacitors. The V10 circuit has a capacitor between the anode of the tube and earth and is, therefore, self extinguishing.

The counting tube anodes are fed through the common anode load resistor marked R_1 (150 k Ω). In addition a smaller resistor (68 k Ω) is included in the anode circuit of each individual tube. These resistors are necessary for the operation of the indicator tube, but are by-passed by capacitors so that they do not affect the counting operation itself. The cathodes of the Z520M tube which are not

shown in Fig. 3.12 as being connected to any particular trigger tube anode are actually connected to the trigger tubes in between V1 and V9; these trigger tubes have been omitted for simplicity.

If a trigger tube is conducting, its anode will be at a lower potential than the anodes of the other counting tubes owing to the flow of anode current through the 68 k Ω anode resistor. There will therefore be a greater voltage between the Z520M anode and the cathode of the Z520M which is connected to the conducting trigger tube than between the Z520M anode and any other cathode. Thus the cathode which is connected to the conducting trigger tube becomes the preferred cathode for the discharge and the Z520M indicates the corresponding number.

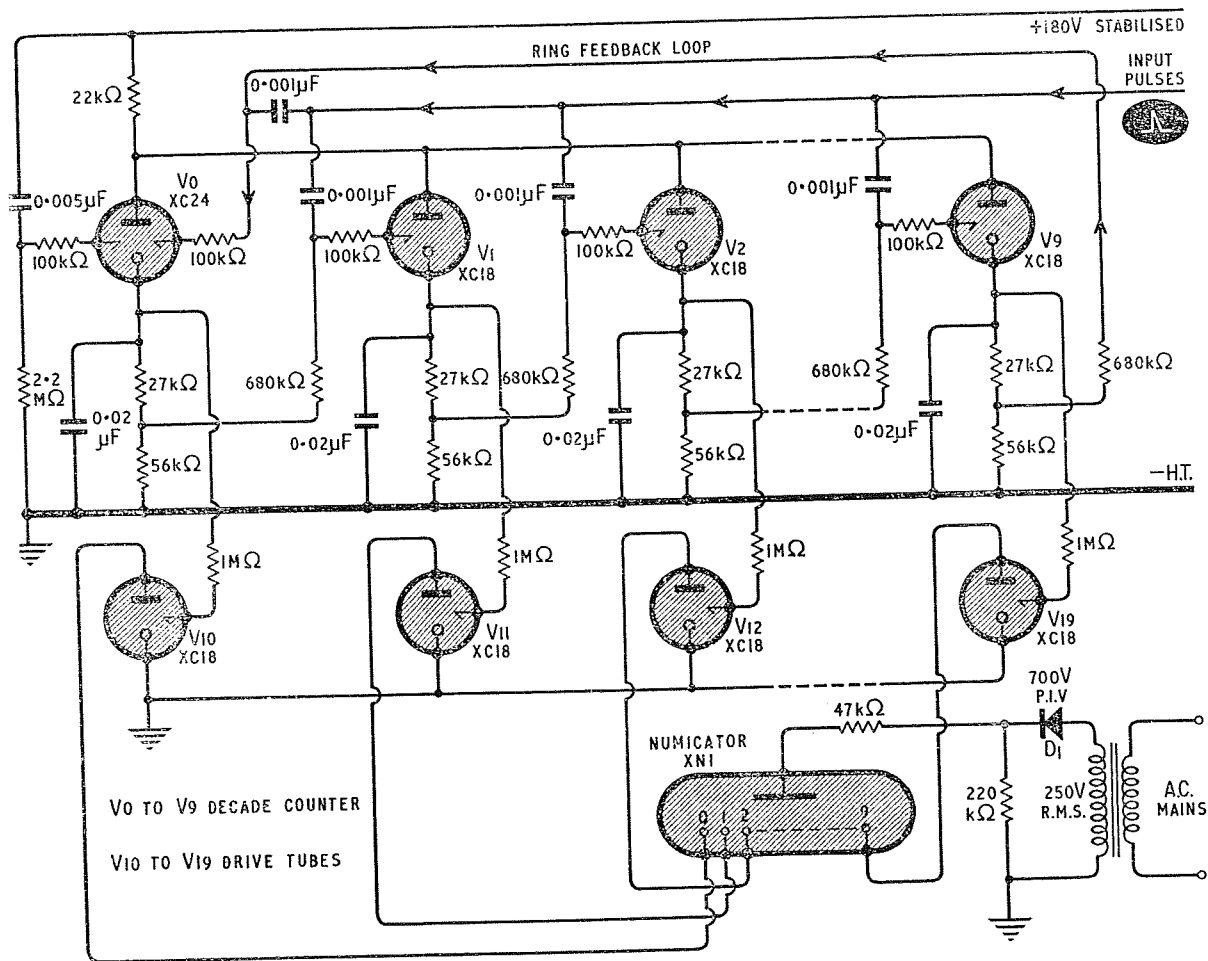

Fig. 3.13 A decade scaler with Numaticator readout

The common anode resistor, R_1 , enables a tube to be extinguished when the discharge is transferred to a succeeding tube by the same mechanism as that discussed previously in connection with the circuits of Figs. 3.5 and 3.7.

If a suitable negative pulse is applied to the cathode of V_0 via the $0.01 \mu\text{F}$ capacitor, the discharge will be transferred to V_0 and thus the decade will have been reset.

The maximum counting speed will be similar to that of the circuit of Fig. 3.8. If desired, Z700W tubes could be used for reversible counting with the Z520M as indicator. A circuit similar to that shown in Fig. 3.12 should be used with the additional trigger electrodes of the Z700W tubes arranged so that the circuit is symmetrical in both the forward and reverse directions.

3.4.8 Numicator Readout

A somewhat different type of circuit is shown in Fig. 3.13 in which XC18 trigger tubes in a decade ring counter are used in conjunction with a 'Numicator' type XN1 digital indicator tube (Hivac) for displaying the state of the count⁽⁹⁾. The first counting tube, V_0 , is an XC24 with two trigger electrodes. One of these electrodes is used for igniting the tube when the circuit is first switched on so that a count of zero is indicated. A pulse travels from the H.T. line through the $0.005 \mu\text{F}$ capacitor for this purpose. The other trigger electrode of V_0 is biased from the cathode of V_9 in the usual way.

The conducting counting tube has a cathode potential of at least 80 V positive with respect to earth. This voltage is applied to the corresponding XC18 drive tube (V_{10} to V_{19}) which is triggered. A current passes from the Numicator anode to the appropriate cathode and hence through the drive tube which has been triggered.

The Numicator is supplied with an unsmoothed half wave rectified supply. The Numicator and drive tube are therefore extinguished during the non-conducting periods of the half wave rectifier. If a count is registered by the decade (V_0 to V_9) during the time the rectifier D_1 is non-conducting, the new state of the count will be shown as soon as D_1 passes a current during the next half cycle. If a count is

registered by the decade whilst D_1 is conducting, two digits may be shown simultaneously for a very small fraction of a second. The true count is shown on the next cycle of the mains voltage. If a d.c. supply were used for the Numicator and the drive tubes, these tubes would not be extinguished when the next drive tube was ignited.

The maximum counting rate of the circuit is of the order of 250 pulses per second, but the Numicator cannot indicate at this speed owing to the wave form of its power supply. A clear indication is, however, given as soon as the counting process ceases.

3.4.9 GTR120W Circuit with Digital Readout

Fig. 3.14 shows a counting circuit⁽¹²⁾ using the very economical subminiature GTR120W trigger tubes⁽¹⁶⁾ with GR10G (Ericsson) digital readout.

The H.T. supply to the circuit of Fig. 3.14 should be 475 ± 25 V. A suitable means of obtaining the other required voltages from the H.T. line is shown using two GD150M stabilisers. The trigger electrodes of the counting tubes are returned to the +150 V line so that no reverse trigger current can flow when the cathodes become positive, since this would damage the tubes.

This circuit differs from the trigger tube ring circuits discussed previously in that separate anode resistors are used for each counting tube and extinction of the tubes takes place by means of the $0.04 \mu\text{F}$ capacitors connecting the anodes of the tubes. No cathode resistors or capacitors are used.

A GTE175M trigger tube is required for coupling the circuit to the next decade. When the tube which indicates zero counts (V_0) is ignited, a current flows through the choke L_1 and a positive pulse is passed to the GTE175M which ignites. This tube provides a positive output pulse from its cathode for the operation of the succeeding decade.

The positive going input pulses should have an amplitude of between 80 and 100 V and a duration of at least $100 \mu\text{sec}$. The maximum counting speed is about 100 pulses per sec. The cathode current of the conducting GTR120W should be about 4.5 mA and the illumination should not be less than 5 ft-candles (50 lx).

ELECTRONIC COUNTING CIRCUITS

is conducting, the right-hand trigger of $V1$ is primed and a pulse applied at the 'subtract' input will cause $V1$ to ignite. The tubes in the ring are extinguished by the action of the common anode resistor ($10\text{ k}\Omega$); the anode circuit is similar to Fig. 3.12.

When $V10$ is conducting, the right-hand trigger of $V12$ and the left-hand trigger of $V1$ will be biased positively. A pulse at the 'add' input will initiate the discharge in $V12$. The flow of current through the cathode resistor of $V12$ will provide a pulse which (in conjunction with the bias) ignites $V1$ and

also operates the next decade. The $V12$ circuit is self extinguishing, owing to the capacitor in its anode circuit. This tube obtains its anode current from a tapping on the common anode resistor feeding the ring circuit. When $V1$ is ignited by the pulse from $V12$, the anode potential of $V12$, therefore, falls somewhat with the anode potential of the tubes in the ring. This enables $V12$ to be extinguished more rapidly than if it obtained its anode supply directly from the H.T. line. The reverse coupling tube, $V11$, operates in a similar way.

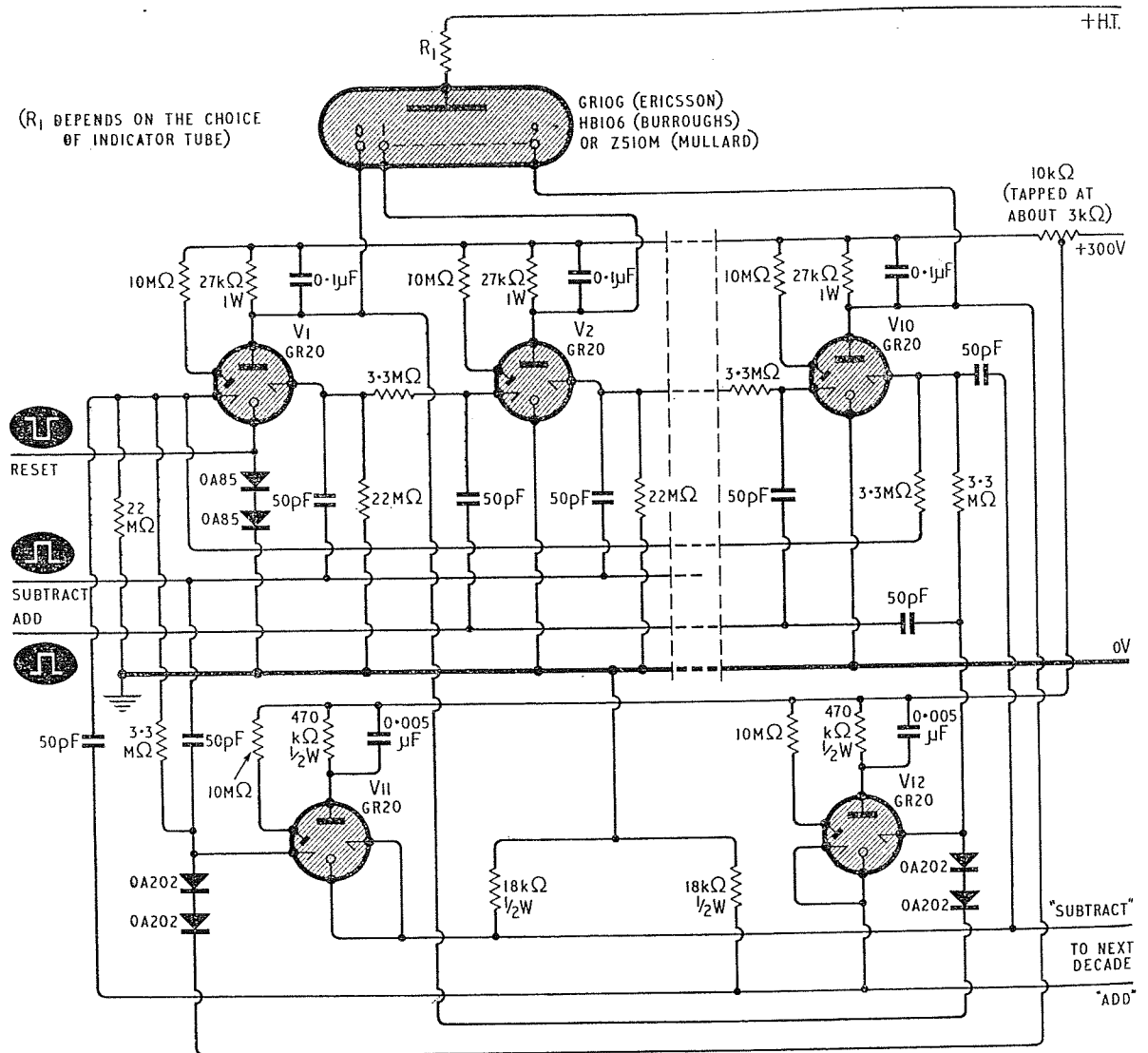

Fig. 3.15 A decade counter using trigger to trigger coupling

SINGLE CATHODE GAS FILLED TUBES AND THEIR CIRCUITS

When V_{10} is ignited, V_9 (not shown), V_{12} and V_1 will receive a bias voltage and this will be conveyed from the trigger of V_1 to the trigger of V_{11} . Thus, if a 'subtract' input pulse is received, not only V_9 but also V_{11} would be ignited if it were not for the presence of the OA202 diodes in the trigger circuit of V_{11} . These diodes prevent V_{11} from being ignited unless V_{10} is in its non-conducting state. The diodes ensure that the trigger of V_{11} is never more positive than the anode potential of V_{10} ; this potential is low when V_{10} conducts. Similarly V_{12} does not ignite if V_1 is conducting.

Owing to the high impedance of the trigger circuits, it is easier to reset the circuit by means of a negative going pulse of about 150 V in amplitude and 20 μsec in duration applied to the cathode of the first tube than to apply a pulse to the trigger electrode. When a negative going resetting pulse is applied, the OA85 diodes in the cathode circuit of V_1 prevent the pulse from being shorted to earth, but allow the normal V_1 anode current, however, to flow.

The positive going input pulses to the circuit of Fig. 3.15 should have an amplitude of 100 to 150 V and a duration of at least 20 μsec . When the trigger electrode of a GR20 tube is connected to earth via a 22 M Ω resistor and the tube anode current is 8 mA, the trigger potential rises to about 80 V with respect to the cathode; this value varies only slightly with changes in anode current caused by supply voltage changes. The H.T. supply to the numerical indicator tube should be equal to 110 V (the maintaining voltage of the GR20) plus the normal working voltage of the indicator tube plus the voltage drop across the indicator tube anode resistor. The absence of a cathode resistor in the trigger tube circuits enables a lower H.T. supply potential to be employed than in many other trigger tube circuits which use a numerical indicator tube. A maximum frequency of 1 kc/s can be obtained if the H.T. supply voltage has a tolerance of $\pm 10\%$.

3.4.12 The G1/371K Tube

The S.T.C. G1/371K tube is a primed trigger tube of the special construction shown in Fig. 3.16⁽¹⁸⁾. A discharge passes between a priming anode and a

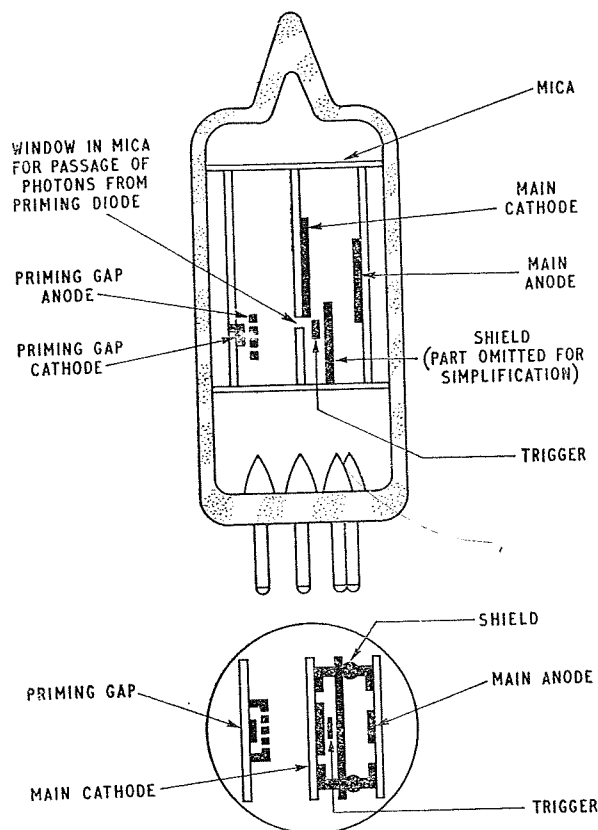

Fig. 3.16 The electrode structure of the G1/371 K trigger tube

priming cathode in a separate compartment. The light generated by this priming discharge passes through a mica window into the cathode-trigger space of the other compartment. The special construction of this tube enables ionisation times as low as 0.5 μsec to be attained.

The electrodes in the main section of this tube are the anode, cathode, trigger and shield. The shield is biased so as to provide an electric field which will remove ions quickly; it may also be used as an auxiliary triggering electrode in certain circuits. The geometry of the electrode structure is designed to enable ions to be removed very quickly and deionisation times of about 30 μsec can be attained without difficulty; when the cathode current is only a little above the recommended minimum value of 2 mA, deionisation times of about 10 μsec are obtainable. This is much shorter than that obtained with conventional trigger tubes and enables

ELECTRONIC COUNTING CIRCUITS

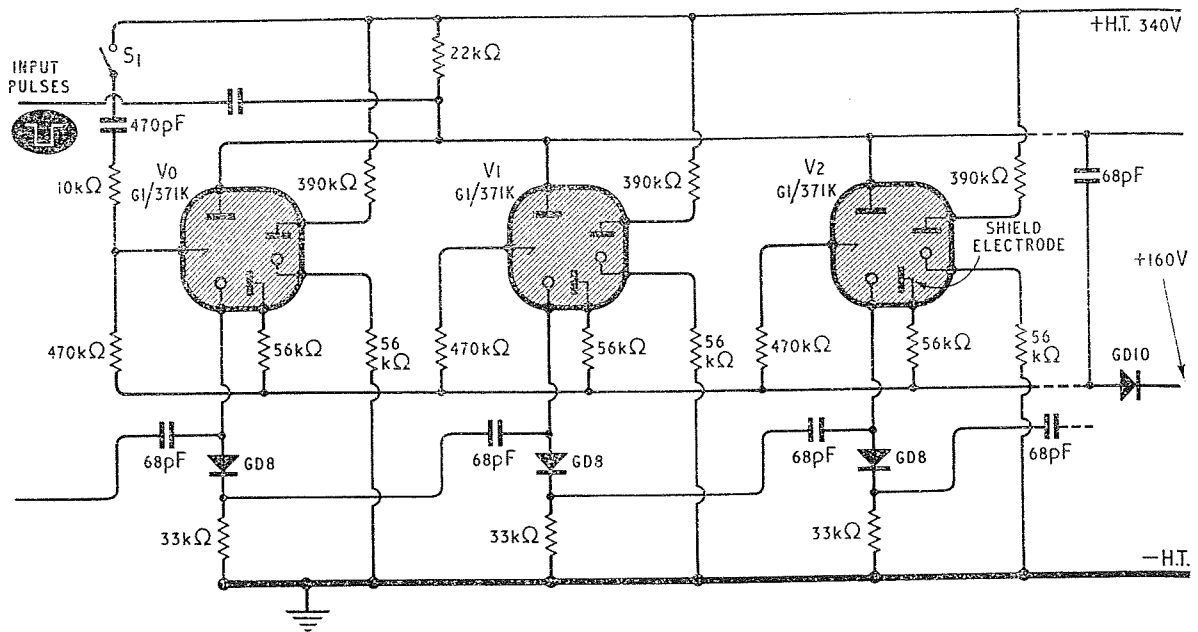

Fig. 3.17 A chain counter using the G1/371K trigger tube. The priming diode is shown on the right-hand side of each tube

the G1/371K to be used in counting circuits at frequencies up to 100,000 pulses per second.

3.4.13 High Speed G1/371K Counters

Fig. 3.17 shows the circuit of a chain counter using G1/371K tubes⁽¹⁸⁾. The basic principle of operation of this circuit is the same as that of the diode counting circuit of Fig. 3.3, but much greater counting speeds are possible.

When S_1 , the reset and starting switch, is momentarily closed, V_0 conducts. If a negative pulse is now applied to the input, V_0 is extinguished and its cathode becomes more negative. This negative pulse is applied to the cathode of V_1 via the 68 pF coupling capacitor. The diode in the cathode circuit of V_1 prevents the negative pulse from leaking rapidly away. At the end of the input pulse the trigger to cathode discharge in V_1 is transferred to the main gap.

The negative input pulses are also coupled to the trigger and shield electrodes via a 68 pF capacitor. This is necessary in order that premature triggering and loss of triggering energy before the end of the pulse shall be prevented. On the other hand the

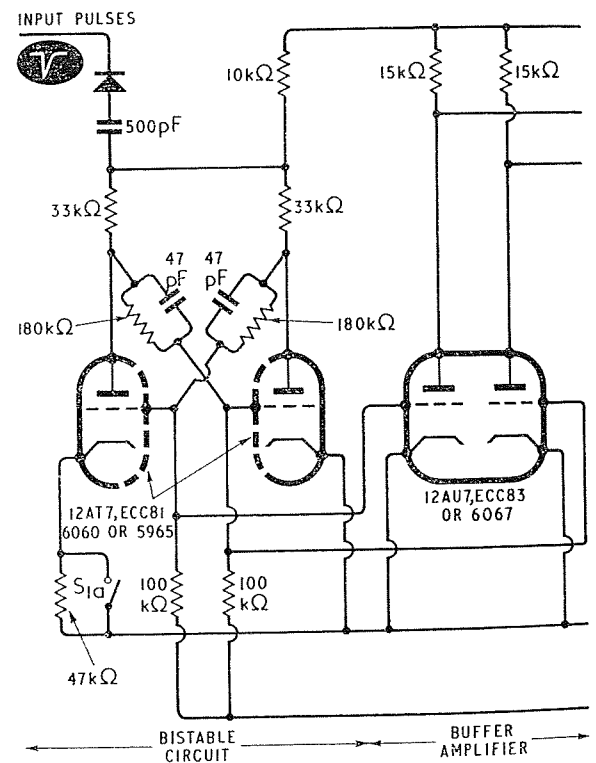

Fig. 3.18 A high speed ring counter.

reduction in the shield potential lowers its deionising efficiency and this (together with the common anode capacity) limits the maximum counting speed.

These limitations can be largely overcome by the techniques shown in the circuit of Fig. 3.18 which can count at frequencies of up to about 100,000 pulses per second⁽¹⁸⁾. The input pulses fed into this circuit operate an Eccles-Jordan stage which feeds a 12AU7 buffer amplifier. The anodes of alternate trigger tubes are connected together and the potentials of the two sets of anodes are swung in anti-phase by the buffer amplifier. A tube can be triggered within about a microsecond of the previous tube being extinguished.

The switches S_{1a} and S_{1b} are used for starting and resetting the circuit. They are ganged so that the state of the Eccles-Jordan circuit is always matched to that of the trigger tube circuit. The use of the negative line shown in Fig. 3.18 is essential if the sharp cathode wave forms required at high counting speeds are to be obtained.

3.5 DESIGN OF TRIGGER TUBE RING CIRCUITS

In order to illustrate the general methods by which ring circuits may be designed, let us assume that a trigger tube circuit of the type shown in Fig. 3.19 is to be designed using GR21 tubes⁽¹⁹⁾. The following information may be obtained from the tube data sheets:

	Symbol	Min.	Max.
Maintaining voltage	V_m	106 V	116 V
Trigger ignition voltage	V_t	130 V	155 V
Cathode current	I_k	2.5 mA	8 mA
Anode supply voltage	V_b	180 V	270 V
Control capacity		40 pF	5,000 pF

In order that a tube shall ignite only when both the pulse and bias voltages are fed to it, the following three conditions must be satisfied:

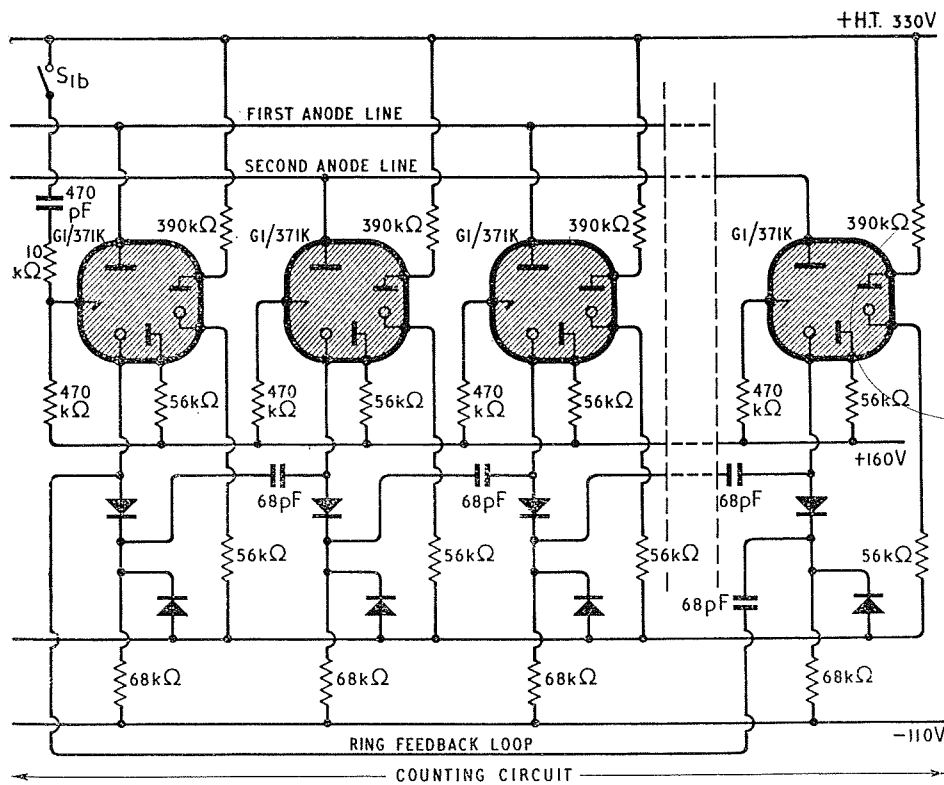

All diodes are S.T.C. types GD8 or GD10

ELECTRONIC COUNTING CIRCUITS

$$V_{1 \max} < V_t \min \quad (1)$$

$$V_i \max < V_t \min \quad (2)$$

$$V_{1 \min} + V_i \min > V_t \max \quad (3)$$

The following equations may be derived from the circuit:

$$V_{1 \min} = (V_b \min - V_m \max) \frac{R_3 \min}{(R_3 \min + R_1 \max)} \quad (4)$$

$$V_{1 \max} = (V_b \max - V_m \min) \frac{R_3 \max}{(R_3 \max + R_1 \min)} \quad (5)$$

$$I_{K \min} = \frac{V_b \min - V_m \max}{R_3 \max + R_1 \max} (> 2.5 \text{ mA}) \quad (6)$$

$$I_{K \max} = \frac{V_b \max - V_m \min}{R_3 \min + R_1 \min} (< 8 \text{ mA}) \quad (7)$$

The resistor tolerances will be assumed to be $\pm 10\%$ and at first the design will be attempted using an unstabilised H.T. supply with a tolerance of $+14\%$ to -18% of the nominal value. If the highest value of the H.T. supply is set at the maximum permissible value for tube, the nominal value will be

$$V_b = 270 \times \frac{100}{114} = 237 \text{ V}$$

and the minimum value:

$$V_b \min = 237 \times \frac{100-18}{100} = 194 \text{ V}$$

Putting values in equation (6):

$$I_{K \min} = \frac{194-116}{(R_3 \max + R_1 \max)} = 0.0025 \text{ A}$$

from which

$$R_3 \max + R_1 \max = 31.2 \text{ k}\Omega$$

Allowing for resistor tolerances, the mean value of $(R_3 + R_1)$ is $28.4 \text{ k}\Omega$.

The maximum value of V_1 which may be employed without any tube firing is 130 V . A safety margin of 10 V may be allowed so that $V_{1 \max} = 120 \text{ V}$. This value may be substituted in equation (5):

$$120 = (270 - 106) \left(\frac{R_3 \max}{R_3 \max + R_1 \min} \right)$$

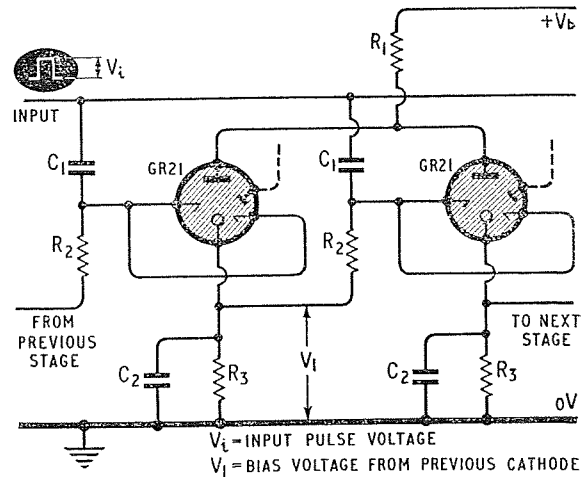

Fig. 3.19 A GR21 chain counter

from which

$$\frac{R_1 \min}{R_3 \max} = 0.367$$

and, allowing for the 10% resistor tolerances, $R_1/R_3 = 0.449$. Combining this with the relationship found above that $(R_3 + R_1) = 28.4 \text{ k}\Omega$, it is found that $R_3 = 19.6 \text{ k}\Omega$ and $R_1 = 8.8 \text{ k}\Omega$.

If these values are substituted in equation (4), it is found that $V_{1 \min} = 50.7 \text{ V}$. Using condition (3) and the fact that $V_t \max = 155 \text{ V}$, $V_i \min = 119 \text{ V}$ (allowing a 15 V safety margin). If this has the same tolerance as the H.T. supply voltage, $V_i \max = 166 \text{ V}$. This obviously violates condition (2) and the design is unsatisfactory.

There are three possible ways in which the circuit may be altered to enable it to operate satisfactorily. Close tolerance resistors may be used, the supply voltage V_b may be stabilised or the variation in the values of V_i may be reduced. If the supply voltage is stabilised this will also reduce the variations of V_i . Three SR2 Cerberus stabiliser tubes may be placed in series to provide a nominal stabilised voltage of 264 V . The maintaining voltage of each stabiliser tube may vary by $\pm 3 \text{ V}$ and, therefore, $V_b \min = 255 \text{ V}$ and $V_b \max = 273 \text{ V}$. This maximum voltage actually exceeds the maximum recommended for the GR21 tube by 3 V , but this is permissible, since the minimum breakdown voltage for the anode to cathode gap is 290 V .

If these values are used in the equations as before, it is found that $R_1 = 16.3 \text{ k}\Omega$ and $R_3 = 34.2 \text{ k}\Omega$. The nearest preferred values of $15 \text{ k}\Omega$ and $33 \text{ k}\Omega$ respectively have been used in the calculation of the following values. Using equations (6) and (7), it is found that $I_{k \text{ min}} = 2.6 \text{ mA}$ and $I_{k \text{ max}} = 3.9 \text{ mA}$.

for counting frequencies of up to 2 kc/s is 47 pF , but it may be increased with decreasing frequency. The minimum value of R_2 ($4.7 \text{ M}\Omega$) is determined by the maximum quiescent trigger current.

The importance of supply voltage and component tolerances in the design of cold cathode tube

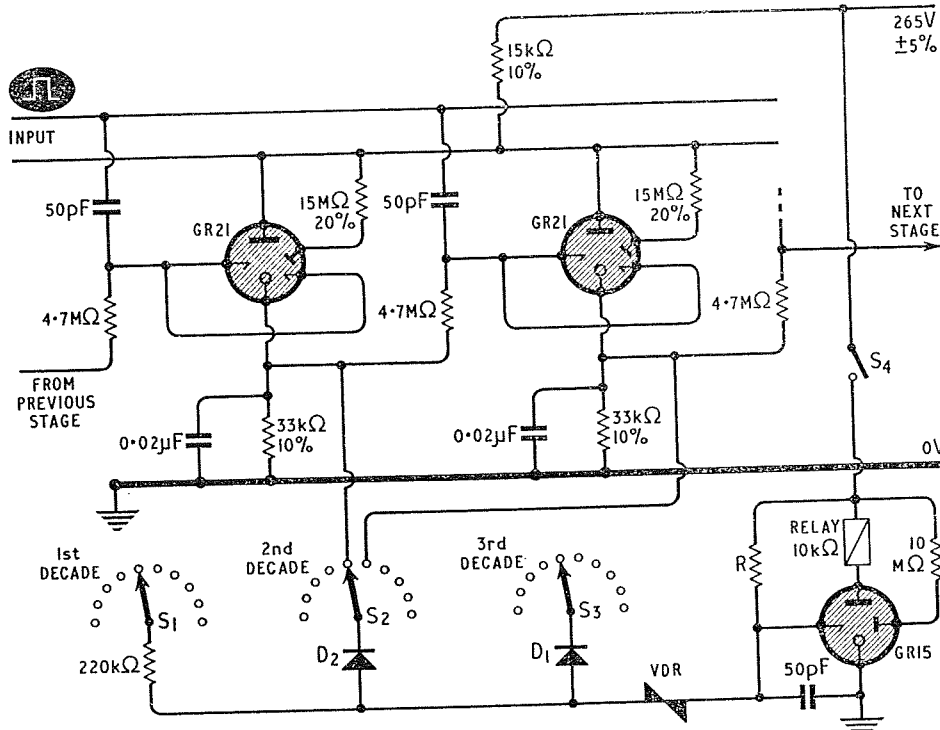

Fig. 3.20 A trigger tube predetermined counter. Only the fifth and sixth stages of the second decade are shown; other stages are identical with them

Using equations (4) and (5), it is found that $V_{1 \text{ min}} = 89.4 \text{ V}$ and $V_{1 \text{ max}} = 121.7 \text{ V}$. All GR21 trigger tubes strike when their trigger to cathode potential reaches $+155 \text{ V}$. If another 20 V in excess of this is allowed to ensure rapid ignition, it can be seen from condition (3) that $V_{i \text{ min}} = 86 \text{ V}$. This voltage can increase by over 40% before condition (2) is violated. In actual practice there is always stray capacitance in the trigger circuit and this forms a potential divider with C_1 . V_i can therefore exceed the maximum calculated value by a small amount.

The value of C_2 is set at about $0.02 \mu\text{F}$ by the deionisation time of the GR21 tube. A lower limit for the value of C_1 is set by the recommended minimum control capacity of 40 pF . A suitable value

circuits can be clearly seen in the above example. A small percentage variation in the H.T. supply voltage (especially if it is fairly low in value) can result in a larger percentage variation in the current taken by the tube, since the maintaining voltage is almost independent of this current.

3.5.1 Predetermined Counting

Output potentials may be obtained from any selected cathodes of a trigger tube ring counter and can be used for the operation of a relay when the state of the count reaches a certain predetermined number. The basic circuit of such a predetermined counter is shown in Fig. 3.20⁽²⁰⁾; the design of the ring

Table 3.1

TABLE OF BASIC TRIGGER TUBE DATA

The data given below is only approximate and may apply only under certain conditions.
Further details are given in manufacturers' data sheets.

Type and Manufacturer	Maximum H.T. Supply Voltage	Approx. Maintaining Voltage	Trigger Striking Voltage	Continuous Current (mA)	Base	Remarks
CERBERUS:						
GR15	270	107	120-140	10-40	B9A	Priming anode.
GR16	350	111	120-140	20-40	B9A	Priming anode; internal shield.
GR20	270	109	120-140	4-30	B9A	Twin triggers; priming anode.
GR21	270	110	130-155	2½-8	submin.	Twin triggers; priming anode.
GR31	350	111	125-140	10-40	B9A	Priming anode.
GR32	205	{105 110}	121-126	5-25	B9A	2 main anodes + priming anode.
GR33	290	105	128-137	25 max.	B9A	Priming anode.
GR41	350	110	120-140	4-10	submin.	Twin triggers; priming anode.
GR43	250	107	115-122	1-5	submin.	Priming anode.
ELESTA:						
ER1	250	107	125-140	10-40	B9A	Priming anode
ER2	340	111	125-140	15-40	B9A	Twin triggers;
ER3	250	107	125-140	10-40	B9A	priming anode.
ER32	340	115	120-140	7-15	submin.	Twin triggers; priming anode.
ER33	260	107	120-140	5-15	submin.	Twin triggers; priming anode.
ENGLISH ELECTRIC:						
*5823	200	62	73-105	25 max.	B7G	Close tolerance versions of the 5823.
*QT1250	210	62	72-80	25 max.	B7G	
*QT1251	210	62	72-80	25 max.	submin.}	
ERICSSON†:						
GDT120M	340	112	105-155	3-9	B7G	Priming diode.
GDT120T	400	112	100-155	5-25	B9A	Priming diode.
GPE120T	250	{105 110}	120-125	25 max.	B9A	2 main anodes; priming anode.
GPE175M	310	150	173-183	3½ max.	B7G	Twin triggers; priming cathode.
GTE120Y	275	106	114-122	1-5	submin.	Priming anode.
GTE130T	290	105	128-137	25 max.	B9A	Two anodes.
GTE175M	310	150	173-183	3½ max.	B7G	Priming cathode.
*GTR80M	200	62	70-90	25 max.	B7G	
GTR120W	310	118	110-170	3-9	submin.	
FERRANTI:						
*GK10	150	75	80	7½ max.	B7G	
*GK32	140	80	85-98	2 max.	3 caps	
*GK33	140	80	85-98	2 max.	3 wires	
*GK40	140	75	79-85	5 max.	3 caps	
*GK42	140	75	79-85	5 max.	3 wires	
G.E.C.:						
*CCT6	250	60-80	70-90	1-5	submin.	

SINGLE CATHODE GAS FILLED TUBES AND THEIR CIRCUITS

Table 3.1 (cont.)

Type and Manufacturer	Maximum H.T. Supply Voltage	Approx. Maintaining Voltage	Trigger Striking Voltage	Continuous Current (mA)	Base	Remarks
HIVAC:						
*XC13	200	70	75	7.5 max.	} submin.	
*XC18	210	73	68	1 max.		
*XC22	210	70	69	1/2 max.		
*XC23	200	67	70	7.5 max.		
*XC24	210	73	68	1 max.		
MULLARD/ PHILIPS:						
Z70U/Z700U	310	116	137-153	2-4	submin.	Priming cathode. Twin triggers; priming cathode.
Z70W/Z700W	310	116	137-153	2-4	submin.	
*Z71U/Z701U	165	60	73-90	3-9	submin.	Twin triggers. Priming anode.
Z803U	290	105	128-137	8-25	B9A	
Z806W	390	110	118-121	12-25	B9A	Priming anode; screening anode. Tritium primed.
*Z900T	200	62	73-95	35 max.	B7G	
R.C.A.:						
*OA4G	225	70	70-90	25 max.	Octal	
*1C21	180	70	66-80	25 max.	Octal	
*5823	200	61	80	25 max.	B7G	
S.T.C.:						
*G1/237G}	200	70	75	1 1/2 max.	submin.	Priming diode+shield.
*G1/238G}						
*G1/371K	360	175	190	10 max.	B7G	
*G150/2D	150	68	70	30 max.	Octal	
*G240/2D	230	90	75	30 max.	Octal	
TELEFUNKEN:						
*OA4G	225	70	70-90	5-25	Octal	Priming anode.
*5823	200	65	70-90	5-25	B7G	
*5823A	350	65	70-90	5-25	B7G	
ZC1010	335	121	157-167	8 max.	submin.	

* Signifies that the cathode is coated with a material of low work function.
 † Now obtainable through Hivac Ltd.

circuit employed has been discussed in the previous section. Two stages of the second decade ring circuit are shown together with the coincidence circuit. Any number of similar decades can be added. The GR21 has two trigger electrodes and may, therefore, be used in reversible ring counters using the principles discussed previously.

The desired predetermined number is set by means of the selector switches S_1 , S_2 and S_3 . If each cathode selected by these switches is conducting, the potential of the junction of the diodes D_1 and D_2 in the coincidence circuit will be raised to a value which will result in the GR15 tube striking

and the 10 k Ω relay in the anode circuit of this tube closing. Some means must be provided for opening the contacts of S_4 after the relay has closed so that the GR15 tube is extinguished ready for the next operation. The contacts S_4 normally form part of a circuit (such as a batching unit) which is operated by the relay in the GR15 anode circuit.

Siemens E50C2 diodes are suitable for D_1 and D_2 . The voltage dependent resistor marked VDR should pass about 100 μ A when the potential difference across it is 100 V; a Philips type VD 1000 P/680 B is suitable. The resistor R should be chosen so that the potential difference across the

ELECTRONIC COUNTING CIRCUITS

voltage dependent resistor is 80 to 100 V. The input pulses may have an amplitude of about 120 V and a duration of about 20 μ sec.

3.5.2 Relay Operation

If it is required to operate a relay or an electro-magnetic counter from a trigger tube circuit, a valve circuit similar to that of Fig. 4.37 will be suitable. The trigger tube replaces the Dekatron, V_1 , the output voltage from the cathode of the trigger tube being fed through the 4,700 pF capacitor into the circuit of V_2 . If no heater supplies for valves are available, however, the circuit of Fig. 4.38 which employs only cold cathode tubes may be more convenient.

REFERENCES

1. G.H. HOUGH & D.S. RIDLER, 'Some recently developed cold cathode glow discharge tubes and associated circuits', *Electron. Eng.*, **24**, 152 (1952); **24**, 230 (1952); **24**, 272 (1952).
2. J.C. MANLEY & E.F. BUCKLEY, 'Neon diode ring counter', *Electronics*, **23**, 84 (1950).
3. 'Trigger Tubes', *Electron. Appl. Bull.*, **16**, 1, 1 (1955/56).
4. 'Glimmrelaisröhren und ihre Diagramme', Telefunken publication No. 58 03 37.
5. 'Philips Cold Cathode Trigger Tubes'. Philips publication No. 20/092/D/E-1-62.
6. 'Philips Subminiature Trigger Tubes'. Z70U. Z70W., Philips publication No. 20/641/D/E-3-62.
7. M. VOLLENWEIDER, 'Kenndaten und Kennlinien von Kaltkathodenröhren', *Cerberus Elektronik*, **3** (1957).
8. F.M. PENNING, *Electrical Discharges in Gases*, Philips Technical Library (1957).
9. R.S. SIDOROWICZ, 'Cold-cathode tube circuits for automation', *Electron. Eng.*, **33**, 138 (1961); **33**, 232 (1961); **33**, 296 (1961).
10. S.T.C. Valve Division publication No. CE1005.
11. Mullard Technical Handbook
12. Ericsson Tube Technical Handbook
13. 'Cold Cathode Trigger Tubes' Ericsson publication No. B. 6305/1 (May 1963).
14. Elesta Schaltepfählungen No. 17.16.12 Ausgabe 9.58.
15. 'Mullard Cold Cathode Tubes', Mullard (1962).
16. A. TURNER, 'The design and manufacture of a low cost cold cathode trigger tube.' *Electron. Eng.*, **30**, 166 (1958).
17. H. LIEBENDÖRFER, 'Ein neuer Kaltkathodenzählring mit direkter Ziffernanzeige.' *Cerberus Elektronik*, **12**, (1959).
18. 'G1/371K High Speed Trigger Tube.' S.T.C. Valve Division application Report No. MS/118.
19. 'Das Entwerfen von Schaltungen mit Kaltkathodenröhren.' *Cerberus Elektronik*, **5** (1957).
20. Cerberus sheets 2.12.21.
21. R. KRETZMANN, *Industrial Electronics Handbook*, Philips Technical Library (1959).

3.6 THYRATRON COUNTING CIRCUITS

Thyratron tubes contain a gas filling, but unlike the tubes used in the circuits discussed in this chapter, they have thermionic cathodes and require a heater supply. They can be used in binary and ring counting circuits which operate in very similar ways to the cold cathode tube circuits discussed in this chapter. Circuits showing how the 2D21 (EN91) thyratron can be used for counting have been published⁽²¹⁾. Thyratrons are not normally used as self indicating devices, although they do glow somewhat in operation. They have been used for counting in the past, but are now seldom employed for this purpose, since other devices have been developed which are much more convenient and consume less power. The maximum frequency at which thyratron circuits can operate is, like all gas filled tubes, limited by ionisation and deionisation times.

Multi-Electrode Gas Filled Counting Tubes And Their Circuits

4 Kc/s double pulse tubes are made by a number of manufacturers, each manufacturer having published different practical circuits for their use. The principle of operation and basic circuit requirements of this type of tube are discussed in Section 4.2, but the practical circuits for these tubes recommended by the various manufacturers are discussed in the section of the chapter covering the tubes of the manufacturer concerned. The principle of operation of other types of polycathode tubes is discussed together with practical circuits for their use in the section which covers the tubes of the particular manufacturer.

4.1 INTRODUCTION

One of the disadvantages of trigger tube counting circuits is that ten of the tubes are required in each decade. Great efforts have, therefore, been made to design cold cathode tubes one of which can replace ten trigger tubes in counting circuits; the resulting polycathode tubes are one of the most commonly used devices in medium speed counting equipment. Most of them can count at frequencies up to four thousand pulses per second, some up to twenty thousand, whilst two types can count at up to one million pulses per second.

Most polycathode tubes require a greater H.T. supply voltage than trigger tube counting circuits, but they usually pass a smaller current than trigger tubes. In common with most other cold cathode tubes, the polycathode counting tubes have a very long life when they are correctly used. The number of components required per decade is usually less when a polycathode tube is being used than when trigger tubes are employed, but a more complicated input circuit may be necessary.

4.1.1 Construction

In practice, simple polycathode gas filled tubes for decade counting usually consist of twenty, thirty or

forty cathodes placed around a single common anode. Groups of the cathodes are joined together internally so that the number of external connections is reasonably small. A discharge takes place between the anode and one of the cathodes when the tube is in operation and a 'negative' glow is formed. The position of the glow can be observed through the dome of the glass envelope and provides a visual indication of the state of the count. Most of the tubes are fitted into an escutcheon on which the digits are marked, but a few of the tubes do not require an escutcheon.

The tubes have the same basic properties as the simple cold cathode gas filled tubes described in Chapter 3. The striking voltage is normally much greater than the maintaining voltage. If a discharge is taking place to one of the cathodes, it can be transferred to an adjacent cathode by the application of a negative going pulse to the latter. The coupling between the two cathodes takes place automatically by means of the ions provided by the discharge at the first cathode. Cathodes adjacent to the discharge are much more strongly primed than any of the other cathodes.

The coupling components which are used in trigger tube circuits are not required when polycathode tubes are used. No priming electrodes are required, since a discharge is always taking place

to one of the cathodes when the tube is in operation. After the transfer has taken place, the discharge to the cathode which was initially glowing is normally extinguished automatically by the fall of anode voltage. In some of the earlier polycathode tubes, however, an additional positive going pulse had to be applied to the cathode which was to be extinguished at the same time that the negative going pulse was applied to the cathode to which the glow was about to be transferred⁽¹⁾.

4.1.2. Types of Tubes

If a tube contains only ten cathodes around a common anode, the glow can be made to move from cathode to cathode by suitable successive negative going pulses applied to each succeeding cathode in turn. This is the principle of the indicator tube to which pulses are fed from a counting circuit. Such a simple tube with only ten cathodes cannot actually perform the counting operation itself, since a circuit is said to be able to count only if it changes its state when successive input pulses are fed into the circuit along the same wire. Indicator tubes (as opposed to counting tubes) require pulses to be fed successively to each of the cathodes along different wires; they are described in Chapter 10.

In counting tubes at least one additional cathode (known as a transfer or guide cathode) is placed between each two adjacent main cathodes. The discharge does not remain at any transfer cathode for more than a very short time. The main cathode at which the glow rests corresponds to a certain digit which can be read from the escutcheon which surrounds the domed end of most of the tubes. If only one transfer cathode is employed between each two main cathodes, all of the transfer cathodes are normally connected together. Negative going pulses to be counted are applied to all of the transfer cathodes, but the discharge can move only to a transfer cathode which is adjacent to the main cathode which is initially glowing, since no other transfer cathode is appreciably primed by the ions from the discharge. At the end of the pulse the discharge is made to travel from the transfer cathode to the next main cathode, usually by means of a positive bias which is applied to the transfer cathodes.

4.1.3 Asymmetrical Tubes

If only ten transfer electrodes are employed and they are all connected together, the electrode geometry must be asymmetrical so that the discharge can travel around the tube only in the desired direction. For example, the main cathodes may be so shaped that the discharge can pass only to the transfer electrode which is one step in a clockwise direction from the main cathode which is initially glowing. The discharge may be prevented from returning to the previous main cathode at the end of the pulse by the effect of a parallel capacitor and resistor from each main cathode to earth. Whilst the discharge remains at a main cathode the capacitor charges and subsequently holds this cathode at a positive potential whilst the discharge is at the succeeding transfer cathode. This technique employing directional main cathodes is used in the S.T.C. G10/241E 'Nomotron' counting tube.

In other types of counting tubes both the main and transfer cathodes are directional. The counting speed is then not limited to such an extent by the effect of the cathode circuit time constant, since the latter does not control the direction of rotation of the discharge. The Elesta EZ10B tube employs this principle. Tubes which use directional asymmetrical electrode structures cannot be used for reverse counting (subtraction).

4.1.4 Symmetrical Tubes

In many other types of tube two transfer electrodes are employed between each two of the main cathodes. The tubes themselves are symmetrical in each direction and the direction of the rotation of the discharge is determined by the timing of the applied input pulses. All of the transfer cathodes which are on the clockwise side of the main cathodes adjacent to them are joined together and are known as the first guides (see Fig. 4.1). Similarly all of the transfer electrodes which are on the anticlockwise side of the adjacent main cathodes are joined together and are known as the second guides.

In operation a negative going pulse is applied to the first transfer electrodes to cause the discharge to move one step and a fraction of a second later another pulse is applied to the second guide electrodes

so that the discharge moves another step. Finally, the discharge moves to the next main cathode at the end of the second guide pulse. Such tubes are known as double pulse tubes, since two successive pulses are required for each counting operation. Three distinct stepping operations take place each time a count is registered. Examples of those tubes operating on this particular principle are the Mullard Z504S, the Ericsson GC10B and the Sylvania 6476.

Another type of symmetrical tube has ten main cathodes and thirty transfer cathodes surrounding a common anode. The Ericsson GC10D is a tube of this type and is known as a single pulse Dekatron, since only one pulse is fed to the circuit to operate this tube.

4.1.5 Counter and Selector Tubes

The 'zero' main cathode of almost all tubes is brought out to a separate base pin so that an output pulse can be taken from it for triggering the next decade. In many counting tubes which are intended for use in simple straightforward counting circuits, the other nine main cathodes are brought out to a single common base pin. Such tubes are known as counter tubes.

Some tubes, such as the Mullard Z504S and the Ericsson GS10C/S, have each main cathode connected to a separate base pin so that an output pulse can be obtained from the circuit after any desired number of counts. This pulse may be used to initiate some external action. Such tubes are known as selector tubes and must be used when electrical readout from any cathode is required. They can perform any function which can be carried out by counter tubes.

Counter tubes can sometimes be manufactured rather more cheaply than the equivalent type of selector tube. In addition, the user of counter tubes has fewer soldered connections to make than the user of selector tubes.

Some tubes are also manufactured in which some but not all of the main cathodes are connected to separate base pins; they are useful in bidirectional counting circuits. A typical example is the Ericsson GC10/4B.

4.1.6 Scale of Twelve

Cold cathode tubes are available with ten main cathodes for decade counting and also with twelve main cathodes for counting on a scale of twelve. Other types of counting tubes, such as EIT tubes and Trochotrons, are not manufactured for scale of twelve operation, presumably because of a lack of demand.

Scale of twelve tubes are useful when pence are to be counted, since one output pulse is provided for each twelve pence counted. Tubes with twelve main cathodes are also useful dividing the number of input pulses by three, four, six or twelve (for example, in conjunction with a decade tube for converting one pulse per second into one pulse per minute).

4.1.7 The Operation of Numerical Indicator Tubes

The Ericsson GCA10G counter and GSA10G selector tubes can be used to drive numerical indicator tubes directly, ten additional anodes being provided in each tube for this purpose. Other cold cathode decade tubes require ten amplifier stages per decade if readout by means of a numerical indicator tube is required.

4.1.8 Maximum Counting Speed

The maximum counting speeds quoted in this Chapter are those stated by the manufacturers of the tube concerned. In some cases operation at considerably greater speeds can be obtained if a stabilised power supply and close tolerance components are used and if the input pulses are accurately controlled in amplitude and duration. Some manufacturers seem to be rather more conservative in their maximum frequency ratings than others. Generally, however, it is not wise to attempt to appreciably exceed the maximum counting speed quoted by the manufacturers of the tube if a reliable counting circuit is required.

Some indication of the safety margin which is available for any tube when it is operating at a certain speed may be obtained by varying the anode resistor (and hence the anode current) of the tube when it is operating at that speed in order to ascertain the anode current range for satisfactory

operation. The actual readings of the anode current should be taken whilst the discharge is stationary in the tube. The anode current should not be allowed to exceed the maximum value for the tube concerned, although input pulse frequencies greater than the maximum recommended for the tube being used may be tried. The anode current range over which satisfactory operation is obtained normally becomes smaller as the operating frequency is increased in the region of the maximum published frequency for the tube. A stabilised H.T. supply is, therefore, normally desirable if the maximum possible operating frequency is required at the expense of circuit simplicity. Tests for reliability of counting using various input pulse amplitudes and/or durations are also very helpful in assessing whether or not a particular tube will operate satisfactorily at a certain counting speed.

Most double pulse tubes have a maximum counting speed of about 4,000 pulses per second, but other types can operate at up to 10,000, 50,000 or 100,000 pulses per second. The single pulse GC10D and the S.T.C. Nomotron can operate at up to 20,000 pulses per second whilst the Elesta EZ10B and ECT100 can count up to one million pulses per second.

The maximum counting speed may be reduced at high temperatures (above about 60° C) owing to the increased pressure of the gas. Substances which can poison the electrode surfaces may also be given off from the glass envelope if the ambient temperature increases, but these substances will not settle on the cathodes if the discharge is circulated. The maximum speed of operation may also be reduced at temperatures below -15 °C.

4.1.9 Life

The life of most types of polycathode gas filled tube is normally many tens of thousands of hours (tens of years). If, however, the discharge is allowed to remain at one cathode and is never circulated, minute amounts of material may be sputtered from the electrodes and be deposited on the adjacent cathodes. The discharge characteristics are different for sputtered nickel and pure nickel⁽²⁾ and after the discharge has rested at one cathode for a

very long time, longer input pulses may be needed for the operation of the tube. The tube may then be considered to be at the end of its useful life, although longer pulses may be used to drive it at low speeds. The sputtered material from the cathodes may also darken the inside surface of the glass envelope.

Longer life can be obtained from some tubes if the discharge is circulated around the tube at least once per week. Alternatively in a multidecade scaler which is to be used at low speeds, the positions of the tubes may be interchanged about once per month so that none of the tubes are used in the slowest decade for more than a month at a time. These precautions are, of course, required only when the discharge is likely to remain at one cathode for a very long time.

Longer life may be obtained from some types of tube if a value of the anode current near to the minimum recommended value is used. This may, however, reduce transfer sensitivity and hence the maximum operating speed somewhat.

No current should be allowed to pass through a cold cathode tube in the reverse direction, since this will probably result in damage to the surfaces of the cathodes.

4.1.10 Design for Optimum Anode Current

The current flowing through the tube should be within the limits specified by the manufacturer. A current greater than the specified maximum value leads to excessive sputtering of material from the cathodes and to short life, whilst a current below the specified minimum value will result in reduced transfer sensitivity and hence to unreliable counting or reduced operating speed. High speed tubes generally require a greater anode current than the simple 4 kc/s double pulse tubes.

The potential across a cold cathode tube is almost independent of the current flowing through the tube provided that it is being operated in the 'normal' region of the characteristic. The current which flows through the tube can be calculated by applying Ohm's Law to the circuit:

$$V_b - V_m = I_a (R_a + R_k) \quad (1)$$

where

- V_b is the H.T. supply voltage
- V_m is the tube maintaining voltage
- I_a is the tube anode current
- R_a is the anode resistance
- R_k is the cathode resistance

A minimum value for the H.T. supply voltage is quoted by the tube manufacturers. If a smaller supply voltage than this is used, the tube may not strike when the voltage is first applied. Since the tubes are not primed, there may be a delay of up to about a minute before they strike if a value of H.T. supply voltage near to the minimum recommended value is employed.

There is normally no upper limit to the H.T. supply voltage which can be used provided that the cathode current is kept within the rating of the tube by a suitable choice of resistor values. In most cases the H.T. supply need not be stabilised.

When the value of R_a has been chosen, the maximum value of the supply voltage may be calculated from the above equation by substituting for I_a the maximum permissible value of the tube current and for R_k the smallest value of resistor which is to be used in any of the cathode circuits of the tube. (The maximum current flows in that cathode circuit which has the smallest value of cathode resistor.)

Similarly the minimum value of the supply voltage may be calculated by using the same equation and substituting in it the minimum permitted value of the tube current and the largest value of cathode resistor which is to be used in any cathode circuit.

In the case of the GS10C/S, for example, let us assume that 100 k Ω resistors are used in alternate cathode circuits and that the anode resistor is 680 k Ω ⁽²⁾. The maximum current will flow when the discharge rests at one of the cathodes which is directly earthed. The maximum permitted current for the GS10C/S tube is 550 μ A and the maintaining voltage is about 192 V. The maximum supply voltage is, therefore, given by:

$$V_{b \max} = (0.00055 \times 680,000) + 192 = 566 \text{ V}$$

The minimum recommended anode current is 250 μ A. The anode current will have its smallest value when the discharge is resting at one of the

cathodes connected to a 100 k Ω resistor. The minimum supply voltage is therefore given by:

$$V_{b \min} = 0.00025(680,000 + 100,000) + 192 = 387 \text{ V}$$

This value is slightly below the minimum recommended value for reliable striking (400 V). The mean of the maximum and minimum values of H.T. supply voltage, that is 475 V, may be used as the H.T. supply voltage design value.

It might appear that this mean value could vary by ± 90 V or have a 64 V R.M.S. ripple. If variations of this magnitude did occur, however, the change in current flowing through the cathode resistors would cause a variation of about ± 10 V on the nominal output voltage of 30. This might well cause unsatisfactory operation of the circuits into which the output voltage is fed.

The circuits of some of the tubes are fairly critical and it is therefore usually advisable to employ a circuit which has been designed and thoroughly tested by the manufacturers of the tube concerned as the basis of any design for a piece of counting equipment.

4.2 4 kc/s DOUBLE PULSE TUBES

Some of the most commonly used cold cathode counter tubes function on the double pulse principle ⁽²⁻⁵⁾. The electrode structure of a double pulse selector tube is shown in Fig. 4.1. The anode is a circular metal disc placed near to the domed end of the tube (Plates 6 and 7). Thirty identical rods of small diameter are placed symmetrically around the anode; they are the main cathodes and the transfer cathodes. There are two transfer electrodes between each two main cathodes. All of the first guides are joined together and all of the second guides are joined together. In a counter tube (as opposed to a selector tube) the main cathodes K_1 to K_9 are also brought out to one common external connection.

The basic circuit for the normal operation of the tube is shown in Fig. 4.2. The tube may be represented as shown, the circular structure being illustrated as a linear one for convenience. The square brackets near each set of transfer electrodes indicate that

ELECTRONIC COUNTING CIRCUITS

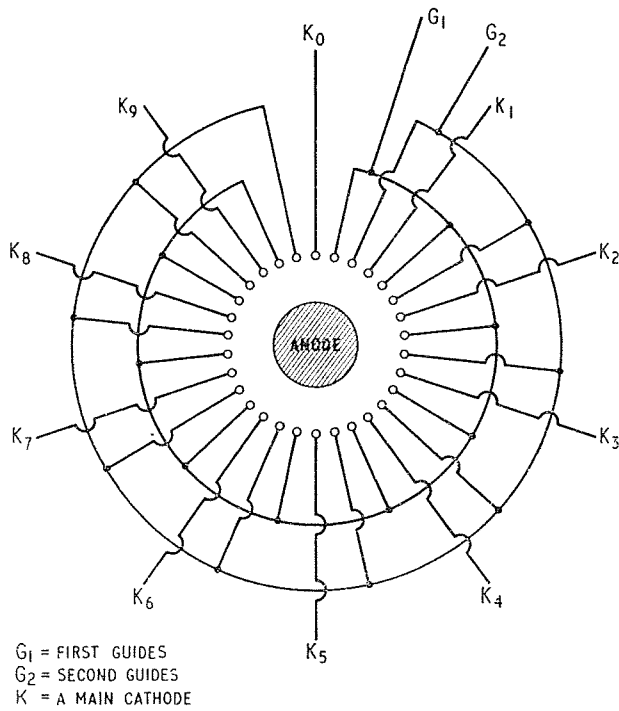
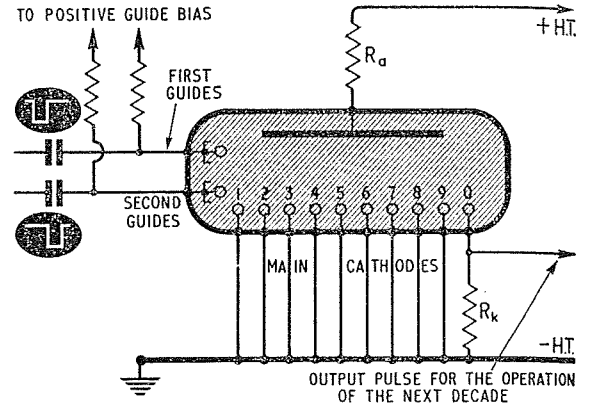

Fig. 4.1 The electrode structure of a double pulse selector tube

Fig. 4.2 The basic circuit for the operation of a double pulse tube



there are more than one first guide and more than one second guide in the tube.

The main cathodes are normally at earth potential whilst both sets of guide cathodes have a quiescent positive potential which is determined by the source of bias voltage. When an H.T. supply of over 400 V is connected to the circuit, one of the main cathodes will strike preferentially to any guide cathode, since the guide bias renders the anode to main cathode potential greater than the potential between the anode and any guide. As soon as ignition has taken place at any one main cathode, the potential between the anode and that main cathode will drop from the striking voltage to the maintaining voltage owing to the fall of potential across the anode resistor, R_a . The anode potential is then below the striking voltage to any other cathode and, therefore, the discharge will occur at only one main cathode.

4.2.1 Double Pulse Counting

The counting operation is performed in three stages. A negative going pulse is first applied to all of the first guide electrodes so that they fall in potential to a value which is appreciably below earth poten-

tial. In a typical double pulse tube with a maintaining voltage of 190 V, the priming effect of the ions from the discharge at the main cathode reduces the striking voltage at the two adjacent guide electrodes to approximately 200 V, whilst the striking voltage at the cathode three positions away is reduced to about 250 V⁽²⁾. If the glowing cathode is earthed, the potential difference between the anode and the first guide will be 200 V when the first guide potential has fallen to -10 V. The first guide which is adjacent to the main cathode, therefore, commences to strike when it is at this potential. No other first guide is sufficiently primed for striking to occur.

As the guide potential falls further, the current to the guide increases so that the operating point moves to the flat portion of the anode voltage/anode current characteristic where the voltage between the anode and the first guides is almost constant and independent of the current flowing. The anode potential falls with the potential of the first guides so that the potential difference between these electrodes is constant and equal to the maintaining voltage for the tube concerned. This fall of anode voltage results in the voltage between the anode and the main cathode falling below the maintaining

voltage of this gap and the discharge to the main cathode is, therefore, extinguished.

The transfer characteristic of the tube for any two adjacent cathodes is of the form shown in Fig. 4.3. It can be seen that as the current passing to the cathode which is about to glow increases, the current passing to the cathode which was initially glowing decreases and the total anode current remains more or less constant.

It should be noted that the guide electrode, which is one position in an anticlockwise direction from the discharge at the main cathode, is a second guide. The discharge shows no tendency to move in an anticlockwise direction to this electrode, since the second guide electrodes are still receiving a positive bias.

The discharge has thus moved one step in a clockwise direction to the first guide and now primes the

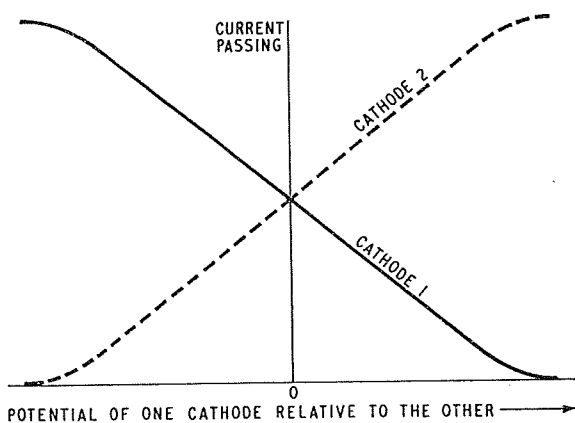

Fig. 4.3 The transfer characteristic for two similar cathodes in a cold cathode tube

succeeding second guide. If the pulse now ceased, however, the discharge would return to its original position at the main cathode owing to the positive guide bias.

When the discharge has been fully transferred to the first guide electrode, a negative going pulse is applied to the second guide electrodes so that their potential is reduced to a value which is appreciably below that of the main cathodes and which is approximately equal to that of the first guides which are still receiving a pulse. The pulse to the first guides terminates soon after the application of the second guide pulse and the first guide poten-

tial rises towards the bias voltage. The anode potential also rises so that the anode to first guide voltage is kept constant at the maintaining voltage of the tube. Soon the anode to second guide primed striking potential of about 200 V is reached. The second guide which is primed then strikes and the anode voltage falls until the anode to second guide potential is equal to the maintaining voltage of the tube. The anode to first guide potential is now below the maintaining voltage for this gap and the discharge at the first guide is extinguished. The discharge has now moved two positions clockwise.

Finally, when the second guide pulse terminates, the anode voltage again rises, since the anode to second guide potential tends to remain constant at the maintaining voltage. When the potential of the second guides reaches about 10 V above earth whilst returning to the quiescent bias potential, the discharge will move one further step in a clockwise direction to the next (primed) main cathode. There is obviously no tendency for the discharge to move in an anticlockwise direction to the first guide, since this electrode is at a positive potential with respect to the main cathode and the anode to first guide striking potential is, therefore, not reached. One of the purposes of the guide bias is to cause transference of the discharge to the main cathode at the end of the second guide pulse. The three successive stepping operations have now been completed and one count has been registered.

The guides are used to determine the direction in which the discharge rotates in the tube. If the second guides receive a negative going pulse and subsequently the first guides receive a similar negative going pulse just before the termination of the second guide pulse, the discharge will move in an anticlockwise or reverse direction. Circuits for addition or subtraction can, therefore, be constructed using double pulse tubes.

When the anode current flows to the zero cathode, K_0 , the voltage produced across the cathode resistor (see Fig. 4.2) can be used to trigger the next decade. The output pulse is not suitable for feeding directly to the counting tube of the next decade, but must be fed into a coupling circuit which amplifies it, changes its polarity and converts it into the required double pulse.

4.2.2 Cathode Resistor and Guide Bias Values

If the cathode resistor is small in value compared with the anode resistor, an increase in the value of the cathode resistor will not appreciably affect the magnitude of the current passing through the tube. The output voltage available at the cathode will therefore be proportional to the value of the cathode resistor if the latter is small.

As the cathode voltage increases with increasing values of cathode resistor, however, it will approach the bias potential of the two sets of guides. Further increases in the value of the cathode resistor then merely cause more of the anode current to flow to the adjacent guides and less to the main cathode (see Fig. 4.3). Any increase in the output voltage as the value of the cathode resistor increases is then negligible⁽²⁾.

Another effect occurs if the guides receive a large positive bias (say +100 V) in an attempt to prevent the above effect from limiting the output voltage. The maintaining voltage of the tube is virtually constant and as the cathode at which the discharge is occurring becomes more positive, the potential of the anode will increase by the same amount as that of the cathode. The non-glowing cathodes remain at earth potential, however, and therefore the potential between them and the anode has increased. The discharge may, therefore, spread somewhat to the adjacent cathode gaps and these may break down at an anode-cathode potential difference of about 250 V which corresponds to a cathode potential of less than +60 V. The glow is especially likely to jump back to the previous main cathode, however, if that cathode has not completely deionised.

The optimum value of the guide bias is normally a compromise between a high value which would result in limited tube life and a low value which would limit the output pulse amplitude. A guide bias of about +40 V is about the maximum which is recommended for 4 kc/s tubes; if this value of bias is used, an output pulse of about 35 V across a 150 k Ω resistor can then be obtained. Under carefully controlled conditions output pulses of 65 V across 200 k Ω cathode resistors have been obtained with a guide bias of +65 V⁽²⁾, but these operating conditions are not recommended for general use.

4.2.3 Negative Cathode Bias

An increased output pulse amplitude can be obtained by returning the cathode load resistors to a source of negative voltage. For instance, if they are returned to a -20 V line, a 50 V output signal can be obtained if the cathodes rise to +30 V when passing a current. The anode potential will then rise to only +220 V (for a tube with a maintaining voltage of +190 V), so that there is no danger of an adjacent cathode striking. The bias potential of the output cathode may also be employed to bias the succeeding valve in the coupling stage to cut off, the cathode of the coupling valve being earthed.

When a negative bias is applied to the output cathode(s), the minimum amplitude of the pulses applied to the first guides must be increased by an amount equal to the negative bias. This ensures that the guides fall in potential by an amount which is sufficient to cause reliable transfer of the discharge from the negatively biased cathodes to the first guides.

It is not wise to return the output cathode load resistor to a bias voltage which is more negative than -20 V, or the discharge may transfer correctly from the output cathode to the first and second guides and then suddenly jump back to it, as it will still be primed somewhat and is at a greater negative potential than the succeeding main cathode. Most of the circuits published by the Ericsson Company for their tubes have the output cathodes returned via the cathode resistor to a -20 V line. The Mullard/Philips circuits employ a -12 V line for the same purpose.

The potential of any cathode which is used to generate an output pulse should not be allowed to rise to within ten volts of the positive guide bias potential or the glow discharge may fail to transfer from it to the succeeding first guide owing to the possibility of current sharing between the main cathode and the preceding second guide electrode.

The maximum recommended value of the cathode resistor in any main cathode circuit is given by the equation⁽⁴⁾:

$$R_{k \max} = \frac{(V_g + V_k - 10)R_a}{(V_b - V_m - V_g + 10)} \quad (2)$$

the output voltage for any value of R_k is given by:

$$V_{out} = \frac{(V_b - V_m + V_k)R_k}{(R_a + R_k)} \quad (3)$$

where V_g is the positive guide bias and V_k is the output cathode negative bias. The other symbols are as defined earlier for equation (1) in Section 4.1.10.

If the values of $V_g = +40$ V and $V_k = -12$ V (as recommended in Mullard/Philips circuits) are used, the maximum value of R_k is found to be 140 k Ω . The preferred value of 120 k Ω is, therefore, recommended and output pulses of 30 V are obtained⁽⁴⁾.

4.2.4 Output Pulse Shape

When the discharge is transferred to the main cathode, the current does not increase very suddenly, but depends on the instantaneous value of the potential difference between the main cathode and the guide from which the discharge is transferred (see Fig. 4.3). The rate of rise of the leading edge of the output pulse is approximately equal to the rate of decay of the trailing edge of the second guide pulse. The transfer from the second guide to the main cathode may not take place at the same potential difference at various positions in the tube and there can be jitter in the time at which the leading edge occurs. The trailing edge of the output signal is produced by the leading edge of the first guide pulse which is usually quite sharp; the trailing edge of the output signal is, therefore, more suitable for use when the pulse is to be employed as a form of time marker⁽²⁾.

The duration of the output pulse is approximately equal to the time during which neither set of guides is receiving a pulse.

4.2.5 Input Pulse Requirements

It is essential that the pulses applied successively to the two sets of guides should be of a suitable amplitude and duration and that they should be correctly timed with respect to each other. Transfer can be effected by a number of types of waveform, but for maximum speed of operation the optimum waveforms are rectangular pulses which have a slight overlap in time as shown in Fig. 4.4.

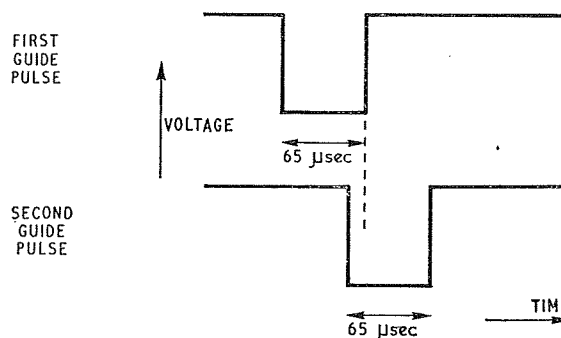

Fig. 4.4 Ideal rectangular negative going pulses for feeding to the first and second guides

It is not usually practical to construct input circuits which convert a single input pulse into two almost perfectly shaped rectangular overlapping pulses for the guides, although a suitable circuit for this purpose has been described⁽³⁾. In actual practice pulses similar to those shown in Fig. 4.5 are usually used. Although the second guide pulse is very different in shape from the ideal pulses of Fig. 4.4,

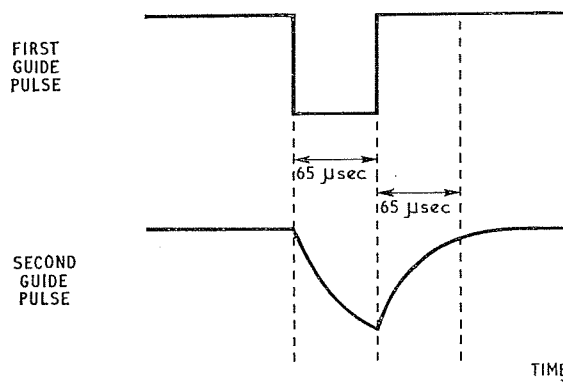

Fig. 4.5 Practical waveforms for 4 kc/s double pulse tubes. The second guides pulses are obtained by integrating the pulses applied to the first guides

the only disadvantage in the use of pulses of the shape shown in Fig. 4.5 is that the maximum operating speed of the tube is slightly reduced. The pulse for the second guides is normally obtained by integrating the first guide pulse by means of a simple resistance-capacitance circuit.

If the pulse to the second guides is applied too soon after the pulse to the first guides, the discharge will not have been fully transferred to the first guides and the preceding second guide will still be

primed to some extent. The discharge will be pulled forward to the first and second guides at the same time as it is being pulled backwards to the preceding second guide with the probable result that no transfer at all will take place.

If the first pulse terminates appreciably before the beginning of the second pulse, the glow will transfer to the first guide, but during the interval between the two guide pulses it will return to the main cathode from which it came. When the second guide pulse is applied, it will move one further step in an anticlockwise direction to the second guide preceding the main cathode at which the discharge initially rested. Finally at the end of the second guide pulse the discharge will return to the initial position at the main cathode.

New tubes may count correctly if a small gap is present between the two guide pulses, but a minimum overlap of one or two microseconds is essential if the tube characteristics have been affected by long stand-by periods⁽²⁾.

4.2.6 Pulse Duration

The pulse applied to the first guides must be of sufficient duration for three successive processes to take place. First of all, the discharge must be established at the first guides and the anode to main cathode glow must be extinguished. Secondly, the priming of the succeeding second guide electrode must take place and, finally, the second guide preceding the main cathode which was initially glowing must have time to become deionised. These processes take a total time of about 65 μ sec, but a nominal first guide pulse width of about 75 μ sec is recommended so that an adequate allowance can be made for tolerances, etc.⁽⁴⁾.

Similarly the pulse applied to the second guide electrodes must be of a sufficient duration for three similar processes to occur. The discharge must be formed at the second guide electrodes and extinguished at the first guides. Secondly, the succeeding main cathode must be primed. In addition the main cathode which was previously glowing must be deionised, but this last process can occur during the total time in which the pulses are applied to the first and second guide electrodes. The required

pulse duration to the second guides is about the same as that to the first guides and a minimum of about 75 μ sec is recommended⁽⁴⁾.

If the guide bias is 40 V \pm 10%, it is recommended that the glow discharge should remain at each main cathode for at least 100 μ sec⁽⁴⁾.

4.2.7 Maximum Counting Speed

The total time occupied by the three separate steps is 75+75+100 = 250 μ sec. The maximum speed of operation is, therefore, about 4,000 pulses per second.

4.2.8 Pulse Amplitude

The use of guide pulses of fairly large amplitude generally results in the most reliable counting. The upper limit of the pulse amplitude is set by the breakdown of the main cathode to guide gap which occurs at a potential of about 140 V. The guide to main cathode voltage should always be appreciably less than this figure or the adjacent main cathode may act as an additional anode, in which case the surface of the electrode would be ruined. In addition, if the guide pulses are too large in amplitude, it is possible for an unprimed guide to strike.

The minimum pulse amplitude which must be applied to the guide electrodes to accomplish the transfer is a function of the pulse duration. It is also dependent on the guide bias; the greater the positive guide bias, the greater the negative pulse voltage required to overcome this bias and to cause the transfer to occur.

If the minimum permissible pulse duration of 65 μ sec is employed, the potential difference required between a primed cathode and anode for transfer is about 231 V for Mullard/Philips tubes. The amplitude of the pulse which must be applied to the primed guide cathode is $(231 - V_m)$ where V_m is the maintaining voltage. This pulse amplitude is equal to approximately 35 V⁽⁴⁾. If the pulse length is increased to 100 μ sec or more, the required anode to cathode potential is reduced to 214 V so that the negative guide pulses need have an amplitude of only about 18 V⁽⁴⁾. A further increase of pulse length will not reduce the required pulse amplitude

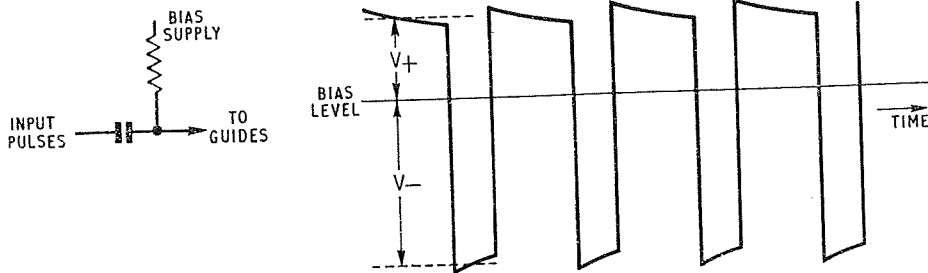

Fig. 4.6 Instantaneous guide potential plotted against time

any further. These figures apply to the least favourable tubes at the start of life.

An optimum anode to guide voltage during the pulse of $V_m + 80 \pm 20$ V is recommended for Mullard/Philips 4 kc/s double pulse tubes. This is equivalent to applying a negative pulse to the first guide equal in amplitude to $V_g + 80 \pm 20$ V where V_g is the positive guide bias voltage. It is also recommended that the second guides should receive a pulse of about the same amplitude. A positive guide bias of $+40$ V $\pm 10\%$ is recommended⁽⁴⁾.

If high speeds are not required, 4 kc/s double pulse tubes may be operated with a guide bias of $+8$ V. Pulses of -15 V in amplitude will then drive the tube. Under these conditions the maximum counting speed is about 700 pulses per second and the output signal amplitude is about 1 V⁽²⁾.

The leading edge of the guide pulses should have a rise time exceeding $1 \mu\text{sec}$ or otherwise a discharge may occur between two of the leads which connect the electrodes to the tube base.

4.2.9 Guide Bias Circuit

When the pulses are fed to the guides through a capacitor, the effective value of the guide bias is different from the applied bias voltage. When a train of rectangular pulses is passed through a capacitor to the guides (Fig. 4.6), the potential at the guide is such that the area of the waveform above the horizontal line representing the applied bias is equal to the area below this line. If the pulse applied to one set of guides is $60 \mu\text{sec}$ in duration with inter-pulse spacings of $190 \mu\text{sec}$ and the total voltage swing ($V_+ + V_-$) is 80 V, it can easily be shown that V_+ will be 19.2 V. V_+ is effectively added to

the steady bias applied to the guides. If the repetition rate is halved, the interval between the pulses becomes $440 \mu\text{sec}$ and V_+ falls to 10 V. Thus if either the pulse amplitude or the mark to space ratio can vary and the tube is to be operated at fairly high speeds, it is essential to use clamping diodes to ensure that the guide bias is kept constant⁽²⁾.

The internal resistance of the bias supply for the guides (R in Fig. 4.7) also requires some consideration. Immediately after a pulse is applied to the guides, the coupling capacitor, C , begins to charge from V_g through the resistor R and also from the current passing through the tube; this charging current also passes through the internal resistance

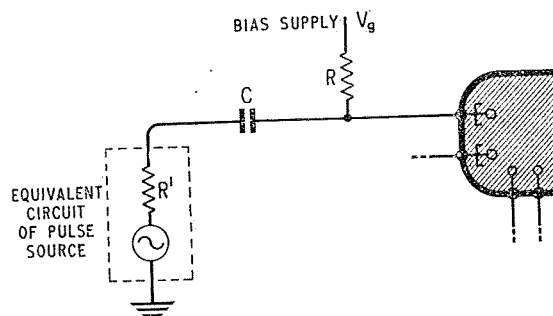

Fig. 4.7 Bias supply impedance

R' of the source of the guide pulses. The potential of the guide rises and if C is small it may rise so much that the discharge moves from the guide whilst the pulse is still being applied to it. R and C should, therefore, be large during the time that the pulse is applied so that C does not charge appreciably from V_g .

At the end of the guide pulse, however, it is desirable that R and C should be small so that C can be

discharged through R and R' in series before the next pulse arrives.

In practice one satisfactory arrangement consists in the use of a fairly large value for C and a diode for $R^{(2)}$. The diode presents a large impedance during the pulse, but its resistance is very low as C discharges by sending a current through it in the forward direction. The use of a potentiometer to supply the guide bias for a number of double pulse tubes is only permissible when the potential divider resistance values are so low that the guide currents of all stages together cause a bias change of only a few volts. Adequate decoupling should be provided.

4.2.10 Basic Guide Integrator Circuit

Normally two suitable separate input pulses are not available for the operation of a double pulse tube and therefore the pulse required for the second

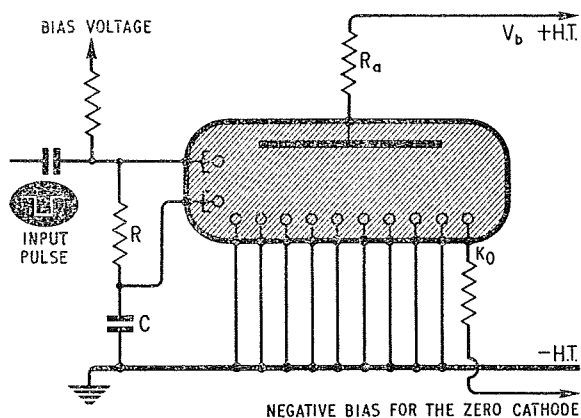

Fig. 4.8 The basic RC integrator circuit for obtaining the two guide pulses from a single input pulse

guides must be obtained from that applied to the first guides. In practice the second guide pulse is almost always obtained by passing the first guide pulse through a simple integrating circuit (see Fig. 4.8). The pulse is delayed by the desired amount, but its amplitude may be reduced somewhat by the integrating circuit. The circuit design is fairly critical, since a compromise between the desired second guide pulse amplitude, width and delay must be made. Numerous pulse shapes are possible, but satisfactory results will normally be obtained if a

voltage at least equal to the minimum recommended transfer voltage is maintained for at least the minimum recommended transfer time with a suitable overlap. The form of the integrated second guide pulse is shown in Fig. 4.5.

When the negative going input pulse of about 120 V in amplitude is applied to the input of the circuit of Fig. 4.8, the first guide potential falls and the capacitor C begins to charge from the negative pulse. The time constant for this charging is determined by the values of R and C ; by a suitable choice of these components the potential of the second guides can be made to reach the transfer potential after any desired time.

At the end of the input pulse the first guide potential rises immediately to the guide bias voltage, but the capacitor C takes time to discharge through the resistor R and the bias supply resistors. The second guide potential thus rises exponentially to the guide bias level as shown in Fig. 4.5 and the transfer is then complete.

4.2.11 Anode Capacity

If the tube anode to cathode capacity is excessive, the anode potential may be prevented from rising rapidly as the guide potential rises at the end of the second guide pulse. The anode to second guide potential may then fall below the maintaining voltage of the tube so that the glow is extinguished. The anode voltage will rise and ignition may occur at any of the ten main cathodes. This difficulty is most likely to occur when the trailing edge of the second guide pulse is steep; for this reason the slope of the trailing edge should not exceed $100 \text{ V}/\mu\text{sec}^{(2)}$. Stray anode circuit capacitance should also be minimised by soldering the anode resistor directly to the tag of the tube base. The problems associated with the anode circuit capacity become much more acute when high speed cold cathode tubes are used.

4.2.12 Reset

When a discharge is present at any place in a 4 kc/s double pulse tube, the striking voltage of any anode to cathode gap does not exceed about 300 V. The

ischarge may, therefore, be reset to zero (or, in the case of a selector tube, to any desired digit) by causing the above potential difference to be present for a short time across the gap to which it is desired to transfer the discharge. There are two basic methods by which this may be accomplished⁽²⁾.

If the glowing cathode is earthed, the anode potential will be about +190 V with respect to earth. If any other cathode receives a pulse which reduces its potential to at least 110 V below earth potential, this cathode will strike. The anode voltage will fall to +80 V so that the potential across the tube is equal to the maintaining voltage. The cathode which was initially glowing will therefore be extinguished.

Alternatively the cathode to which it is desired to transfer the discharge may be left at earth potential and all of the other cathodes may be pulsed to at least 110 V above earth potential. The anode potential will commence to rise towards +300 V, but as soon as the discharge strikes at the desired anode-cathode gap, the anode potential will fall again to +190 V. This is only +80 V higher than the potential of all the other cathodes and the discharge to the cathode which was initially glowing will, therefore, be extinguished.

Practical circuits for double pulse tubes have been designed by a number of manufacturers; typical examples are included in Sections 4.3-4.5.

4.3 MULLARD/PHILIPS COLD CATHODE DECADE TUBES AND THEIR CIRCUITS

Double Pulse 4 kc/s Counter: Z303C (CV2271).

Double Pulse 4 kc/s Selectors: Z502S (CV2325) and Z504S.

Double Pulse 50 kc/s Selector: Z505S.

Tube requiring no coupling amplifier between stages: Z302C.

4.3.1 4 kc/s Double Pulse Tubes

The same circuits may be used for all three of the electrically similar 4 kc/s double pulse tubes. The Z303C is a counter tube with an international octal base. The Z502S has a B12E base with a bottom

cap which projects through the centre of the base, whilst the smaller Z504S has a B13B base.

4.3.2 The 4 kc/s Mullard Input Circuit⁽⁴⁾

The recommended Mullard input circuit for double pulse 4 kc/s tubes is shown in Fig. 4.9. The E88CC double triode is used in a cathode coupled monostable circuit which generates the required rectangular pulse of 75 μ sec duration when it is suitably triggered. The first guide pulse is passed to the integrating circuit $R_{12}C_5$ and the resulting pulse is fed to the second guides. The circuit will operate a double pulse tube over the range 0 to 4 kc/s with a supply voltage tolerance of $\pm 10\%$. In this type of circuit the amplitude and width of the guide pulses are independent of the normal variation in the valve characteristics during life.

The triode V_{2a} is normally conducting whilst V_{2b} is normally cut off by the bias developed across R_4 by the current flowing to V_{2a} . The grid potential of V_{2a} and hence the cathode potential of both triodes is determined by the values of the potential divider R_1 , R_2 and R_3 which are chosen to provide a nominal cathode voltage of 78 V for the triodes. This cathode voltage determines the anode current which will flow when V_{2b} is switched to the conducting state.

When a suitable negative going pulse is fed into the circuit of Fig. 4.9, V_{2a} is cut off and this results in the bias to V_{2b} being reduced. This triode, therefore, conducts. The capacitor C_3 maintains the potential at the grid of V_{2b} at nearly its quiescent level, since this capacitor discharges relatively slowly through R_7 .

The anode current of V_{2b} is determined by R_4 whilst the anode load (which is effectively R_6 and R_{12} in parallel) determines the amplitude of the first guide pulse (120 V). The capacitor C_2 discharges through R_3 and R_6 and V_{2a} will return to its original conducting state after a time determined by C_2R_3 (R_6 is small compared with R_3). The values shown in Fig. 4.9 have been chosen so that the circuit returns to its original state after 75 μ sec.

When V_{2b} returns to its quiescent condition, a positive pulse occurs at its anode. This pulse is prevented from reaching the guide electrodes of the

ELECTRONIC COUNTING CIRCUITS

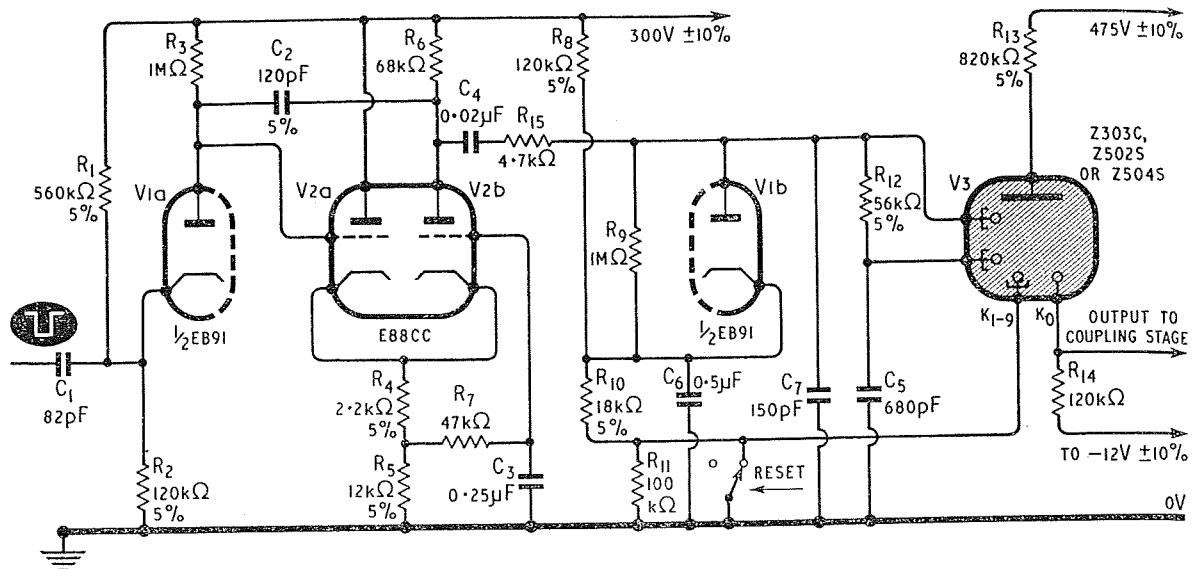

Fig. 4.9 An input circuit for the Mullard Z303C, Z502S or Z504S tubes. Component tolerances are 10% unless otherwise stated

counter tube by the diode *V1b*. Thus the guides do not rise above the bias potential.

The diode *V1a* prevents the positive going trailing edges of the input pulses from causing *V2* to return prematurely to its quiescent condition.

Input Pulses

The negative going leading edges of the input pulses should have slopes of not less than 10^8 V/sec and their amplitude should not be less than 30 V for satisfactory operation of the input circuit of Fig. 4.9.

The time constant of $R_{12}C_5$ which determines the form of the second guide pulses is 38 μ sec. The second guide pulse width varies from 80 to 90 μ sec as the supply voltage varies from +10% to -10% of its nominal value. Both guide pulse amplitudes can vary by about 10 V in either direction from the nominal value of 120 V as the supply voltage varies within the permitted tolerances.

4.3.3 Mullard Valve Coupling Circuit for 4 kc/s Tubes

The amplitude of the output pulse from the zero cathode of *V3* in the circuit of Fig. 4.9 is about 42 V; the maximum positive potential reached by this cathode is, therefore, 30 V. The output pulse is

positive going and its duration can vary from 100 μ sec upwards depending on the length of time for which the discharge rests at the zero cathode of the counter tube. If this pulse is to be used to drive a succeeding decade, it must be fed into a coupling circuit which will convert it into a negative going rectangular pulse of about 120V in amplitude and 75 μ sec in duration.

A practical coupling circuit for coupling two decade counter tubes is shown in Fig. 4.10. Only one half of an E88CC double triode (*V2*) is used in the coupling stage; in a multidecade counter the other half of the E88CC tube may be used in a succeeding coupling stage.

When no discharge is present at the zero cathode of the preceding counter tube, *V1*, the grid of the triode *V2* is maintained at -12 V and the valve is cut off. When the discharge in *V1* rests at the zero cathode, the grid potential of *V2* rises and the valve conducts. The anode potential of *V2* thus falls from that of the H.T. positive supply to about +100 V; this negative anode pulse is used to provide the pulses for the succeeding counter tube, *V3*. The potential divider R_6 - R_7 taps off the required 120 V pulse for the first guides. The second guide pulse is obtained by integration of the pulse at the anode of *V2*.

MULTI-ELECTRODE GAS FILLED TUBES AND THEIR CIRCUITS

V_2 conducts for the whole of the time during which the discharge rests on the zero cathode of V_1 . This is 100 μ sec upwards. The maximum frequency at which the first coupling circuit must be able to operate is, of course, 400 c/s which is one tenth of the maximum input frequency.

At high counting speeds (approaching 400 'carries' per second) the anode of V_2 returns to the H.T. positive potential when the valve is cut off at the end of the pulse. The first guide electrodes

The potential divider R_3 , R_4 , R_5 and C_2 shown in Fig. 4.10 which is used to provide the bias and reset voltages may be used as a common supply for up to five further coupling stages.

Resetting to Zero⁽⁴⁾

The main cathodes and guides are normally returned to the H.T. negative line in Figs. 4.9 and 4.10 by the reset switch. If this switch is opened, the potential of all cathodes other than the zero cathode

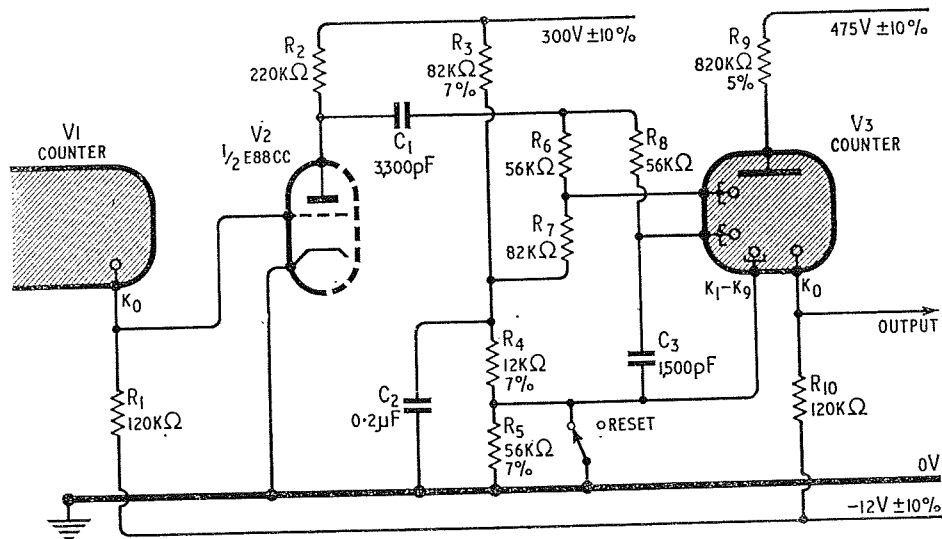

Fig. 4.10 A valve coupling stage for the Mullard Z303C, Z503S or Z504S tubes. Component tolerances are 10% unless otherwise stated

return to the positive bias potential and the discharge in V_3 is transferred first to the second guides and then to the next main cathode.

At low counting speeds the transfer must be completed before the trailing edges of the pulses arrive from V_1 . The discharge transfers to the first guides by the same mechanism as at high speeds, but the transfer to the second guide and to the next main cathode depends on the rate of flow of charge to C_3 . The transfer is always completed within 1 msec. The second guide pulse has a smaller effective amplitude (about 50 V) than the first guide pulse at low operating frequencies, but its duration is about 200 μ sec which is long enough to ensure reliable counting. At the end of the pulse from V_1 the guides may rise to a potential above the guide bias voltage for up to about 1.5 msec.

rises to +120 V and the anode rises towards +310 V. The striking potential of the anode to zero main cathode gap is therefore exceeded. When this gap strikes, the anode potential falls and discharges in any other positions are extinguished.

A relay or a manually operated switch may be used for the resetting switch; it must remain open for at least 5 msec. It is also possible to reset the tubes by the application of a negative going pulse with an amplitude of between 120 and 140 V to the zero cathodes of the counter tubes, but precautions must be taken to ensure that the stages which are reset do not pass pulses to the succeeding decades.

It should be noted that the circuit of Fig. 4.10 cannot be driven from the output of a counter tube which does not have its output cathode resistor

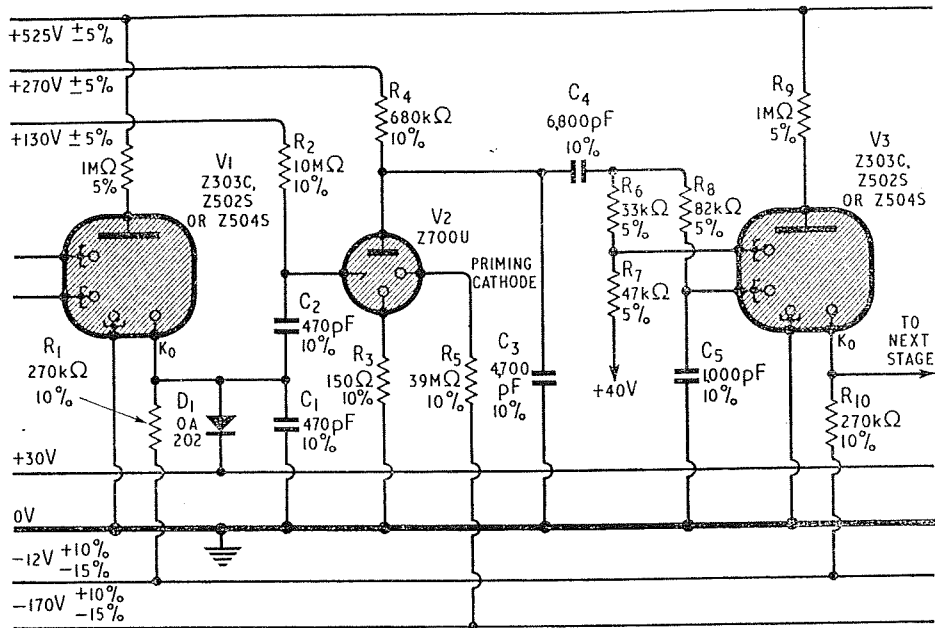

Fig. 4.11 A 40 c/s trigger tube coupling circuit

returned to a negative supply line of about -12 V. If the cathode resistor is returned directly to earth, the output pulse will probably be too small to operate the coupling circuit⁽⁴⁾.

Preferred Tube

The Mullard/Philips special quality valve type E88CC has been specified for the circuits of Figs. 4.9 and 4.10, since the tube has a closely controlled tail characteristic which ensures that either triode is fully cut off when it is biased to -12 V. The E88CC also has the advantage that it is designed for long life where conditions of prolonged cut off may be encountered.

It is possible to use the ECC81 (CV455 or 12AT7) instead of the E88CC, but some current may be passed by a proportion of ECC81 tubes when biased to -12 V. The coupling circuit will then generate a smaller output signal which can result in faulty operation.

4.3.4 Trigger Tube Coupling Circuits^(6,7)

Trigger tube circuits have been designed which will couple two decade counting tubes, only one Z700U trigger tube being required in each coupling circuit

for pulse shaping and amplification. The Z700U has been chosen because of its small size, low cost, low power consumption and short deionisation time which permits operation at frequencies up to 400 c/s. The tube feeding the coupling circuit can thus be used to count at up to its maximum speed of 4 kc/s.

Two coupling circuits will be described; one is suitable for operation at up to 400 c/s whilst the other is a slower but simpler circuit for operation at up to 40 c/s.

4.3.5 40 c/s Coupling Circuit^(6,7)

The circuit for use at frequencies up to 40 c/s is shown in Fig. 4.11. The output pulse from V1 is fed via C₂ to V2 which is ignited. The trigger of V2 also receives a positive bias from R₂. The V2 circuit is self extinguishing owing to the presence of R₄ and C₃. The negative anode pulse from V2 is used to operate the succeeding counter tube.

The maximum voltage which should be present at the zero cathode of V1 is 30 V. If a simple cathode resistor were to be used to return the output cathode to the -12 V line, the output volt-

would depend on the exact values of the components and of the supply voltage. This difficulty is averted in the circuit of Fig. 4.11 by the use of a large K_0 cathode resistor—which alone would provide a pulse exceeding a peak value of 30 V above earth—and by the use of a clamping diode between the K_0 electrode to the +30 V line as shown. As soon as the output voltage tends to exceed 30 V above earth, the diode conducts and prevents any further rise in the output potential. The tolerance on the amplitude of the output voltage is thus determined by the tolerance in the potential of the +30 V line rather than by the wider variations in the anode tube current.

No Z700U tube will ignite at a trigger voltage lower than +137 V, whilst all Z700U trigger tubes would ignite at trigger voltages of +153 V. A bias of 130 V $\pm 5\%$ applied to the trigger electrode of V_2 can be shown to ensure reliable operation with the component and supply voltage tolerances specified⁽⁶⁻⁷⁾.

The time constant of the components C_2R_2 must ensure self extinction and allow full recovery in the time of 25 msec between pulses at the maximum operating frequency of 40 pulses per second.

The capacitor C_1 is necessary to prevent spurious ignition of V_2 at the end of the pulse from V_1 . The manner in which these spurious pulses can arise in the absence of C_1 can be explained as follows. When V_2 is extinguished by the action of R_4C_3 , the anode potential falls to about +60 V in 20 μ sec and drags the trigger voltage with it. A negative going pulse of about 110 V can thus appear at the trigger electrode. This pulse is coupled to the output cathode of V_1 which falls from about +30 to about -60 V. After V_2 has been extinguished the current passing to the zero main cathode of V_1 raises the potential of this cathode to +30 V—which is a 90 V step. This causes the trigger of V_2 to rise from +60 to +150 V, which is enough to cause some Z700U tubes to strike.

When C_1 is incorporated in the circuit, it forms a potential divider in conjunction with C_2 . If these two capacitors are equal in value, only half of the negative going pulse is fed from the trigger electrode back to the zero cathode and the resulting positive going pulse is much reduced in amplitude.

R_6 and R_7 should be large so that a large portion of the output energy from the anode of V_2 is not wasted in the charging of C_4 . On the other hand the total resistance of R_6 , R_7 and R_8 should not be greater than 200 k Ω or the effective guide bias may rise due to the flow of guide current in these resistors. This could reduce tube life.

4.3.6 400 c/s Coupling Circuit⁽⁶⁻⁷⁾

The time constant for the rise of the anode voltage of V_2 of Fig. 4.11 must be greater than 150 μ sec for satisfactory self extinction of the circuit, but this time constant is too short to allow a satisfactory period of rest of the discharge at the first guides. If the time constants are increased to allow the discharge to remain for a suitable time at each of the guides, the maximum operating frequency is limited to 40 c/s.

The slightly more complicated circuit shown in Fig. 4.12 can, however, be used at frequencies up to 400 c/s; it is basically the same circuit as that of Fig. 4.11. The time constant of the trigger tube input circuit has been reduced to 560 μ sec (C_2R_2), whilst C_1 of Fig. 4.12 has the smaller value of 100 pF so that the output voltage rise time is a small fraction of the V_2 input time constant. Although the voltage available for igniting the trigger tube is slightly less than in the 40 c/s circuit, it is still sufficient, however, for satisfactory operation.

The d.c. restoring diode D_3 is added to return the effective guide bias to +40 V at the higher operating speeds. Its cathode is taken to +33 V to compensate for the forward voltage drop in the diode at the higher counting speeds. The addition of D_3 overcomes the objection to the use of larger values of the guide resistors R_6 and R_7 which have been increased in value to minimise the loss in pulse amplitude by the charging of C_4 .

The V_2 anode recovery time has been reduced by the return of R_3 to the 525 V line and the use of D_2 to clamp the anode voltage at the original H.T. level of +270 V as used to supply the trigger tube of Fig. 4.11. C_5 has been reduced to preserve the desired guide pulse amplitude whilst reducing the recovery time.

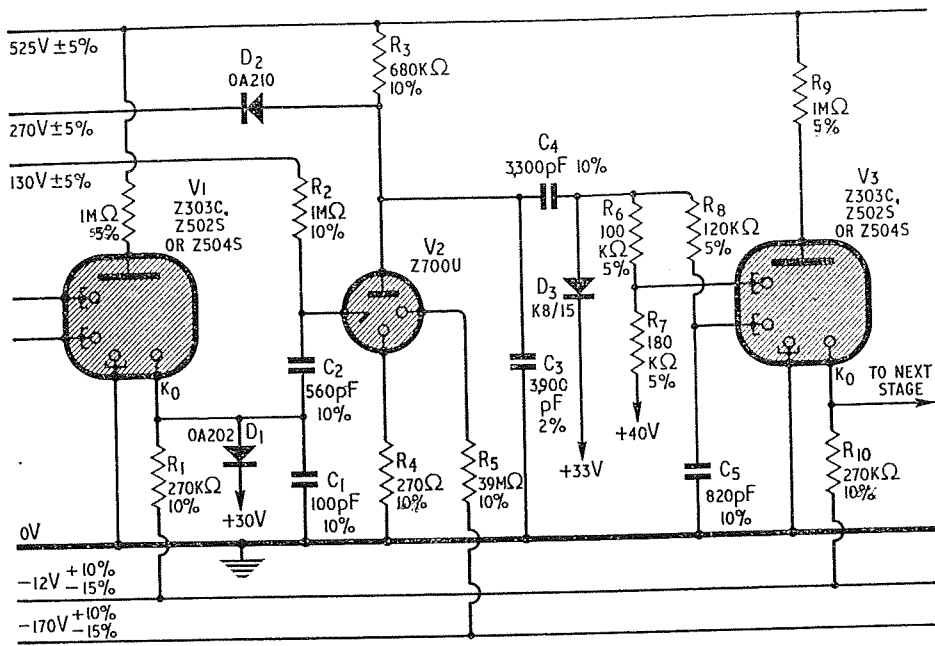

Fig. 4.12 A 400 c/s trigger tube coupling circuit

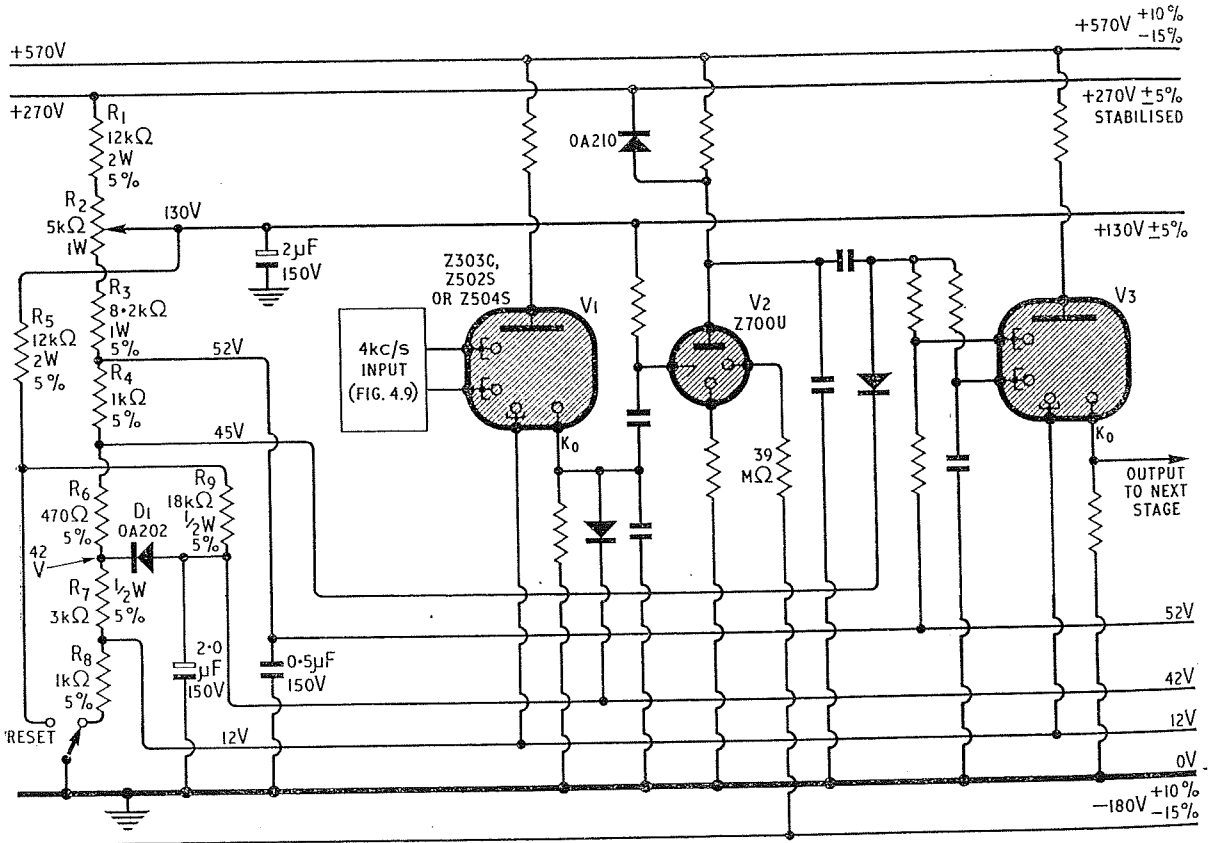

Fig. 4.13 A modified potential divider circuit for use with the power supply of Fig. 4.14. The values not marked are as in Fig. 4.12

Input Circuit

The input pulse to the 400 c/s circuit may be obtained from a counter tube which is fed from the 4 kc/s input circuit of Fig. 4.9. If the complete scaler in which the circuits are to be used will not be required to count at speeds above 400 c/s, a trigger tube circuit similar to the type shown in Fig. 4.12 may be used to operate the first counter tube.

In both the 40 c/s and 400 c/s trigger tube coupling circuits, the priming resistor of the Z700U tube is returned to a negative supply of -170 V so that the priming discharge is not extinguished when the anode circuit of the tube ignites and the anode voltage falls to about $+60$ V.

4.3.7 A Power Supply for Trigger Tube Coupling Circuits ⁽⁶⁻⁸⁾

The power supply requirements of the trigger tube coupling circuits can be somewhat simplified if the circuit of Fig. 4.12 is rearranged as shown in Fig. 4.13 and similar modifications are made to the slower circuit of Fig. 4.11.

In order to avoid the necessity for a -12 V supply line for the zero cathodes of the counter tubes, these cathodes are returned to earth and the other counter tube main cathodes are returned to a $+12$ V tapping on the potential divider chain. The output cathode reference potential then becomes $(32+12) = 42$ V and the required guide bias level $(40+12) = 52$ V. The potential divider network shown in Fig. 4.13 is fed from the $+270$ V stabilised supply.

Reset

When the reset switch of Fig. 4.13 is operated, the potential of all of the main cathodes except the zero cathode increases to about $+125$ V and the discharge therefore moves to the zero cathode.

In order to prevent the output cathode diodes from being damaged by excessive peak inverse voltages, these diodes are effectively disconnected from the potential divider by the diode D_1 during the resetting operation. D_1 is returned to earth through R_9 and is thus reversed biased during the resetting operation. When the reset switch returns

to its normal position, the capacitors connected from the $+130$, $+52$ and $+42$ V supply lines to earth prevent any excessive transient voltage rise in these line potentials.

4.3.8 The Power Supply Unit

Three power supply lines are required to operate the circuit of Fig. 4.13.

- They are: (a) An unstabilised supply of $+570$ V
 (b) A stabilised supply of $+270$ V
 (c) An unstabilised supply of -180 V

All of these may conveniently be obtained from the circuit of Fig. 4.14 which employs a Z806W trigger tube for stabilising purposes. This tube has a very stable ignition voltage and this determines the degree of stabilisation obtained. The electrode shown connected to the junction of R_7 and R_8 in Fig. 4.14 is a screening anode, whilst the electrode connected to R_9 is the priming anode. The Z806W has a B9A base.

The 425 V R.M.S. supply from the transformer undergoes full wave rectification by the four diodes (D_1 to D_4) and C_1 is charged via D_5 and R_1 . The resistor R_1 is included so as to reduce the rate of rise of the counter tube anode supply voltage and to prevent spurious breakdowns within the counter tubes immediately after the circuit is switched on.

When the potential of the anode of the Z806W tube rises to a predetermined value (270 V), the portion of this voltage tapped off by R_5 causes the tube to ignite. The voltage at the junction of R_2 and R_3 falls when the tube ignites and D_6 thus receives a reverse bias so that all of the current passes through the tube. At the end of the half cycle of the mains supply the trigger tube will be extinguished.

During the next half cycle the anode voltage of the tube rises until D_6 conducts and any charge which has passed from C_3 into the load is replaced so that the potential difference across this capacitor again rises to 270 V. The trigger tube then ignites and the diode D_6 is reversed biased so that no more current can flow through it until the next half cycle.

The diode D_5 prevents the capacitor C_1 from maintaining the potential of the tube anode at the maintaining voltage during the time when the

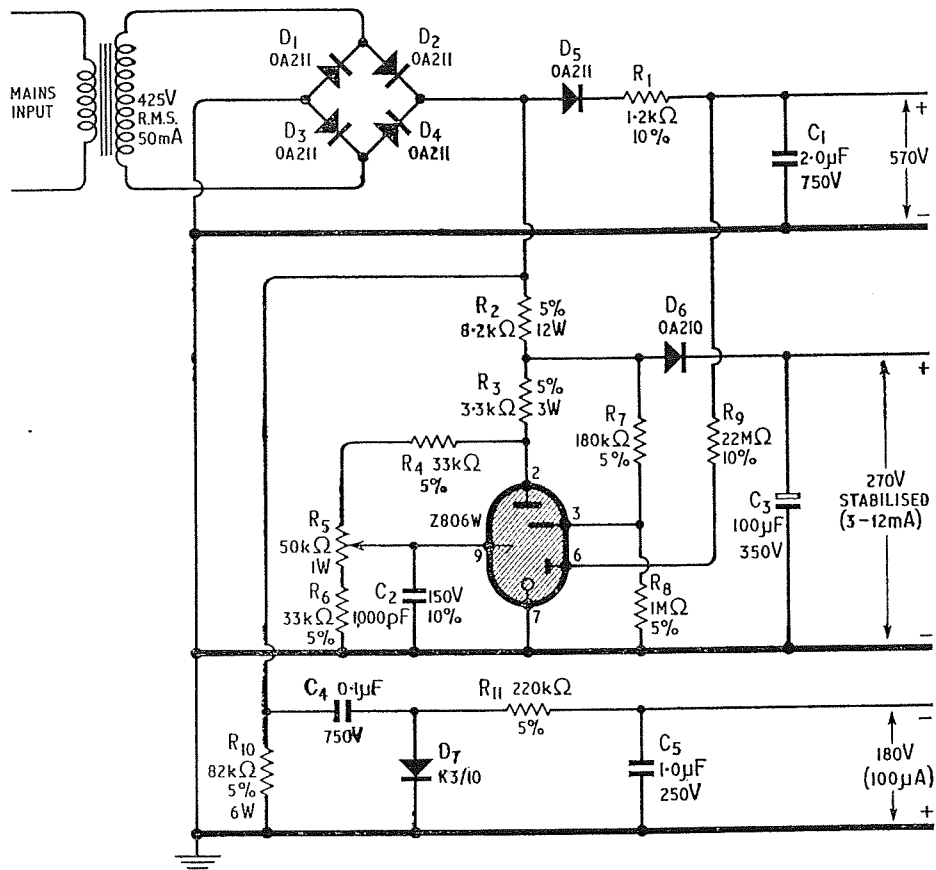

Fig. 4.14 The power supply for the scaler of Fig. 4.13

instantaneous voltage from the mains transformer is small.

The negative supply for the priming cathodes of the Z700U coupling tubes is obtained from the output of the bridge rectifier. The resistors R_{11} and R_{10} act as a potential divider and ensure that the charge on the capacitors cannot be fed back so as to hold the anode voltage of the Z806W at a value which would prevent the tube from being extinguished.

The circuit of Fig. 4.14 should not be operated without any load connected to the stabilised +270V supply or the current passing through the Z806W tube will be excessive. The tube current increases as the load decreases.

The variation in the stabilised output voltage of the circuit when loaded by a six stage scaler is less than 0.6%. The variable resistors R_2 of Fig. 4.13

and R_5 of Fig. 4.14 may be used for setting the 130 V and the 270 V lines to their nominal values. If a stabilised voltage other than +270 V is used to supply the circuit of Fig. 4.13, it is only necessary to modify the value of R_1 .

The trigger tube coupling circuits which have just been described are very suitable for use in small or portable equipment owing to the small size of the tubes used, the low power dissipation and the absence of heaters. Each decade can be conveniently constructed as a module which may be plugged into the complete unit.

4.3.9 Transistor Coupling Circuit ⁽⁹⁾

The circuit of Fig. 4.15(a) shows how transistors may be used to couple counting tubes. The output pulse from a counting tube is passed to an OC75 trans-

istor current amplifier which feeds a pulse to a pair of ACY17 transistors employed in a cascode circuit. They drive the first guides of the succeeding counting tube, the second guide pulses being obtained by means of a modified integrator circuit. The cascode pair are used instead of a single transistor owing to the difficulty of obtaining a transistor with a sufficiently high voltage rating at low cost.

If the discharge in $V1$ is not at the ninth cathode, $T1$ is bottomed. $T2$ and $T3$ are also normally bottomed so that the first guides are at a potential which is only slightly smaller than the +45 V supply. When the discharge reaches the ninth cathode of $V1$, $T1$ is cut off and its collector potential falls. The flow of current through the emitter-base junction of $T2$ effectively clamps the base potential of this transistor to +45 V and no pulse is applied to $V2$.

When the discharge in $V1$ leaves the ninth cathode, $T1$ is bottomed again and a positive going edge of about 9.4 V in amplitude is applied to the base of $T2$. The cascode pair are thus cut off and a negative pulse is applied from the collector of $T3$ to the first guide. $T2$ and $T3$ remain cut off until the coupling capacitor has discharged to a point at which the base potential of $T2$ falls to the emitter potential. The duration of the pulse applied to the first guides is determined by the negative supply voltages and the time constant of the circuit which couples $T1$ to $T2$.

The second guide circuit has been designed so that the discharge remains at the second guides for at least 160 μ sec. This is achieved by means of a diode and a 10 M Ω resistor through which current flows to complete the charging of the integrating capacitor.

A diode is used in the base circuit of $T3$ (and $T6$) to clamp the base voltage of these transistors to -9.4 V. When the cascode pair are suddenly cut off, the base current in each transistor is reversed. A considerable reverse current can flow until the stored holes are neutralised. If the diode were omitted, the base potential of $T3$ would fall to such an extent that the collector-base voltage rating of $T2$ would be exceeded.

The value of the OC75 collector resistor must be small enough to allow the coupling capacitor to

fully discharge during the time the glow rests at the ninth cathode. In the case of $V1$ this may be as short as 100 μ sec if this tube is operating at 4 kc/s. A collector resistor of 2.2 k Ω is suitable. In any subsequent slower stages the resistor value may be increased to reduce the current consumption; a 5.6 k Ω resistor is recommended for any coupling stage after the first.

The circuit of Fig. 4.15(a) requires positive power supply voltages of 500 V at 0.5 mA per stage and 45 V at 12 mA per stage. A negative supply voltage of -65 V at 12 mA per stage is also required. The -9.4 V supply may be obtained from the -65 V line by the use of an OAZ207 zener diode; the current required from the 9.4 V line is 5 mA for the first coupling stage and 2 mA for each succeeding stage.

This type of circuit in which the coupling pulse is obtained from the ninth cathode of the counting tube has some advantages over trigger tube and hard valve coupling circuits in which the pulse is taken from the zero cathode when it is to be used for batching or timing operations. The delay per stage as a scaler based on the circuit of Fig. 4.15(a) moves from 09999 to 10000 is only about 2 μ sec and this minimises errors in coincidence gating circuits.

It is probable that a complete transistor coupled stage (including the Z504S tube holder) can be made in module form with a volume less than 1 in³.

The valve input circuit of Fig. 4.9 may be used for driving the first counting tube of Fig. 4.15(a), but it is usually more convenient to employ the transistor blocking oscillator driving circuit of Fig. 4.15(b).⁽⁹⁾ Input pulses greater than 6 V in amplitude and not less than 2 μ sec in duration can be used to drive the ACY17 transistor, $T1$, of the blocking oscillator circuit. A fairly large number of turns are employed on the secondary windings of the transformer so that the output pulses have an amplitude great enough to drive the decade tube, $V1$. The leading edge of the pulse from L_4 is used to drive the first guides, but the trailing edge cannot pass through the OA202 diode. The second guides are driven by the trailing edge of the blocking oscillator pulse; this is taken from L_5 so that it is of the correct polarity to drive the guides.

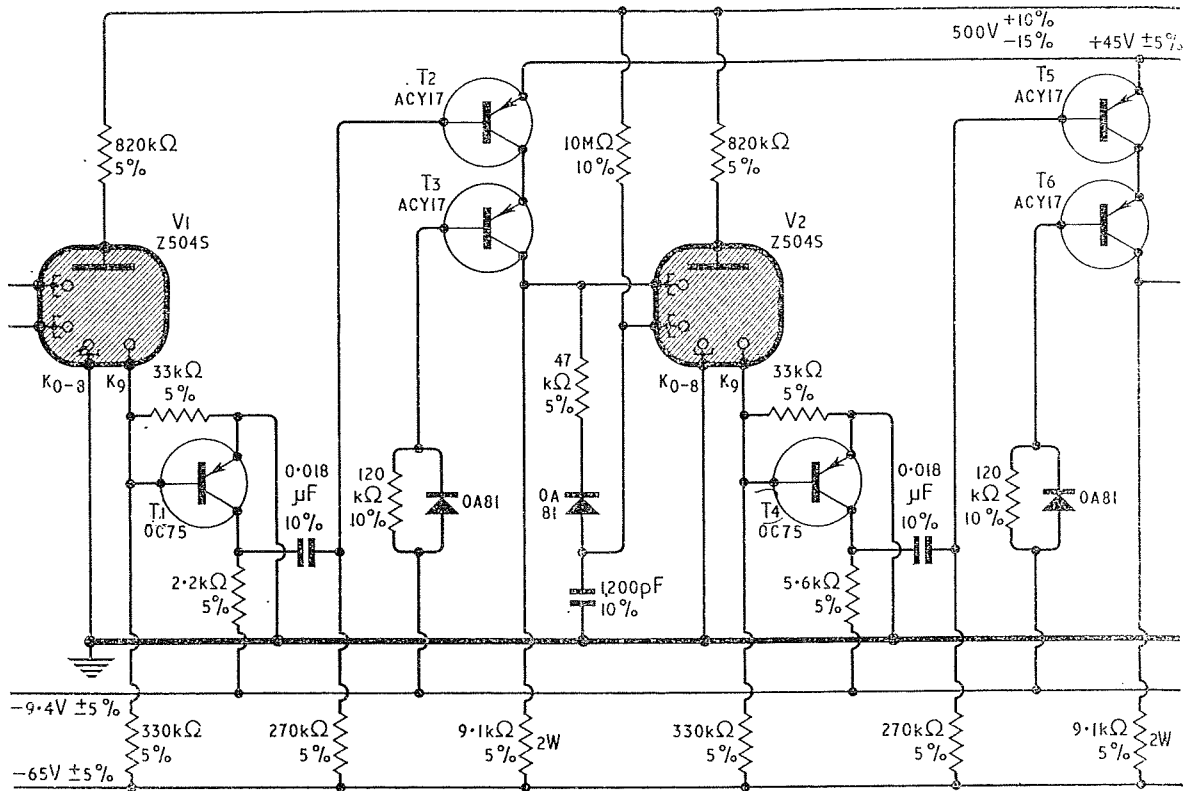

(a)

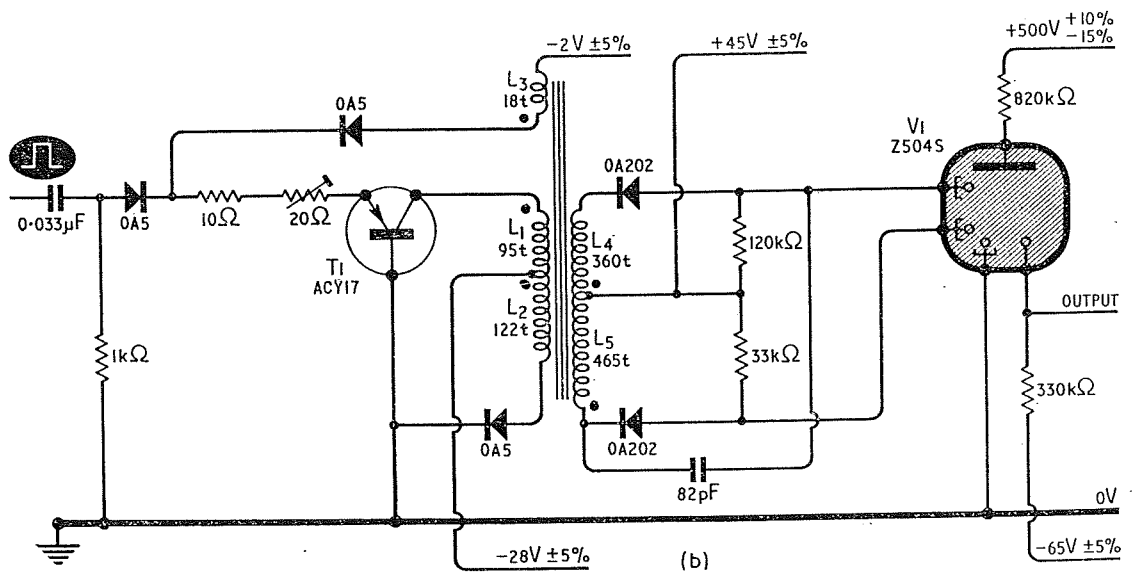

(b)

Fig. 4.15(a) Transistor coupling stages; (b) a blocking oscillator circuit for driving the Z5045, etc.

MULTI-ELECTRODE GAS FILLED TUBES AND THEIR CIRCUITS

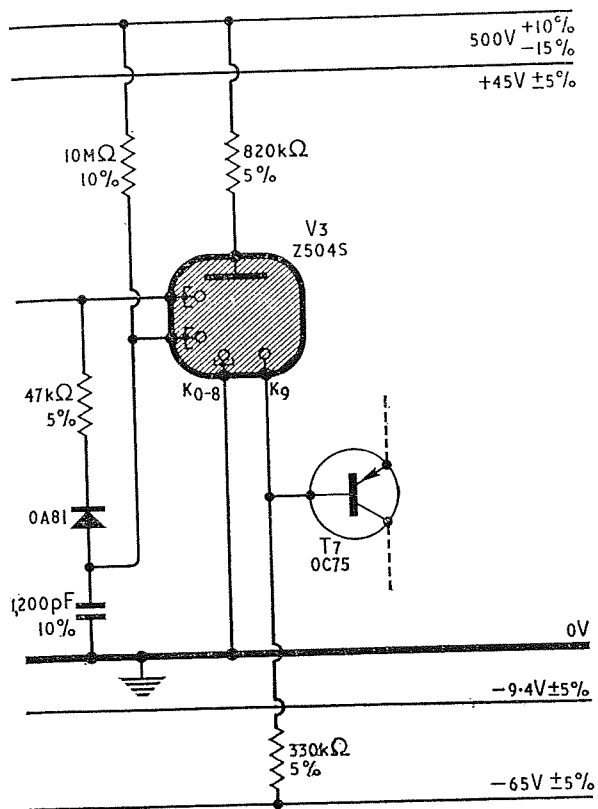

TRANSFORMER DETAILS

Core: - Mullard FX2240
 Bobbin type DT2179
 Tag plate DT2227
 Clamping nut DT2155 (6B.S.)

Winding order	No. of turns
L_1	95
L_2	122
L_3	18
L_4	360
L_5	465

4.3.10 Sine Wave Drive for 4 kc/s Tubes⁽⁴⁾

When a double pulse tube is to be used to count the peaks of a sine wave, the simplified input circuit of Fig. 4.16 can be used. The input sine wave is

applied to the second guides if clockwise rotation of the glow is required and if the negative peaks of the wave are to be counted. The sine wave which is applied to the second guides is also changed in phase by C_2 and R_2 and the resulting sine wave is applied to the first guides. The wave applied to the first guides leads that applied to the second guides in phase if clockwise rotation is desired.

The input voltage to the circuit of Fig. 4.16 should be between 40 and 70 V R.M.S. and the frequency must not exceed the maximum operating frequency of the tube (4 kc/s). The value of the capacitor C_2 required depends on the input sine wave frequency and is shown in the table beneath Fig. 4.16.

The positive guide bias required is only 8 to 10 V, since the positive half cycles of the input waveform provide the additional bias required.

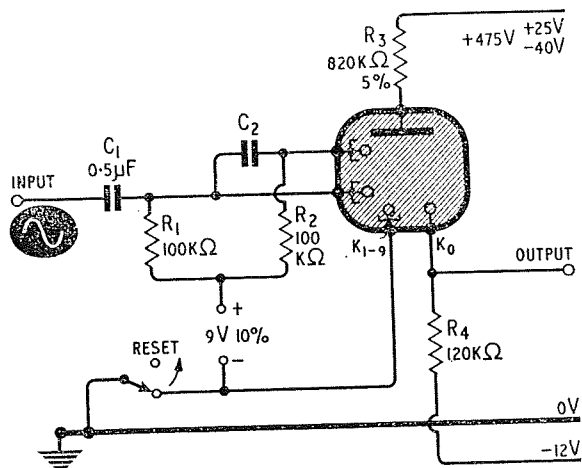

Input frequency (c/s)	50	100	200	500
C_2 (μF)	0.1	0.05	0.02	0.01

Input frequency (c/s)	1000	2000	4000
C_2 (μF)	0.005	0.002	0.00068

Fig. 4.16 A sine wave drive circuit for the Mullard 4 kc/s double pulse tubes. Component tolerances are 10% unless otherwise stated

ELECTRONIC COUNTING CIRCUITS

It should be noted that if a multidecade counter is required for sine waves, the output pulses from the circuit of Fig. 4.16 are not steep enough to operate the coupling circuit of Fig. 4.10 if the frequency of the sine wave input is below about 300 c/s. The circuit can be modified for low input frequencies⁽⁴⁾.

The circuit of Fig. 4.16 is very similar to the Ericsson circuit of Fig. 4.22. Neither of these circuits can count every peak from the moment the sine wave input is applied, since a short time is necessary for the correct phase relationship to be established at the first guides. It is obvious that no first guide peak will precede the first peak applied to the second guides, since each peak actually reaches the second guides before its effect reaches the first guides.

4.3.11 The Operation of the Z504S Above 5 kc/s⁽¹⁰⁾

The maximum operating frequency of the Z504S tube is limited by the fact that an output pulse must be obtained from the tube for the operation of the coupling circuit of the next decade. It has been found that if all cathodes of Z504S tubes are connected directly to earth, all of the tubes will operate at frequencies up to 18 kc/s and most tubes of this type will operate at over 25 kc/s.

In the circuit of Fig. 4.17 an OC71 transistor is connected as a grounded emitter amplifier to convert the current pulse from the output cathode into a voltage pulse. The transistor is normally held in the bottomed condition by a current of approximately 180 μA which flows through the emitter-base circuit and through the 68 k Ω resistor. When the discharge in the Z504S passes to the output cathode, the 350 μA cathode current supplies the 180 μA taken by the 68 k Ω resistor and also supplies an additional current of about 170 μA to the transistor base. The direction of the current passing in the transistor base lead is therefore reversed and the transistor is cut off. The collector potential changes from nearly zero volts to -12 V.

A negative output pulse of -12 V can thus be obtained without the output cathode of the Z504S changing by more than 0.3 V from the earth potential. The transistor may be connected to the ninth

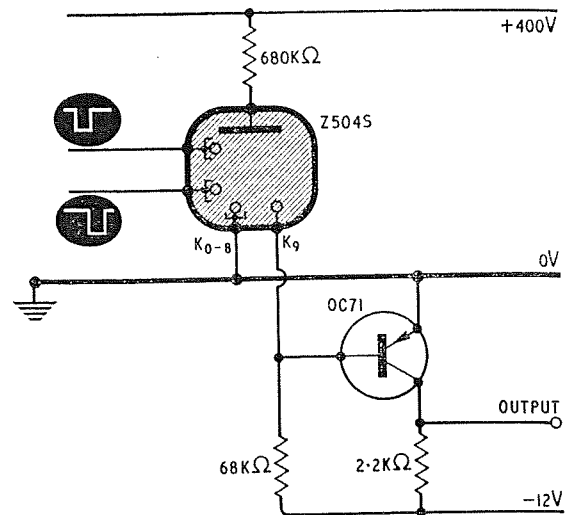

Fig. 4.17 Operation of the Z504S at 10 kc/s

cathode of the tube. The 12 V negative going output pulse can be differentiated so that, when the discharge leaves the ninth cathode for the zero cathode, a positive going pulse is obtained which can be used to drive a hard valve coupling stage.

Measurements have been made on several Z504S tubes operating in this type of circuit and it has been found that operation at 10 kc/s could be achieved without any sacrifice in reliability⁽¹⁰⁾. The negative going input pulses to the tube under these conditions should have an amplitude of 100 V and a duration of 33 μsec .

4.3.12 The Z505S Tube

The Mullard Z505S tube is a double pulse selector tube which can operate at frequencies up to 50 kc/s, since the duration of the guide pulses may be 6 μsec as opposed to the 75 μsec pulses required by the 4 kc/s tubes. Various circuits are available⁽¹¹⁾.

The tube may be used with 15 k Ω cathode resistors returned to earth, in which case 12 V output pulses are available. Cathode resistors should be used only in those cathode circuits from which outputs are required; the remaining main cathodes should be returned to earth. Alternatively the Z505S may be used with the one output cathode returned to a -12 V supply via a 32 k Ω resistor; output pulses of about 24 V are then obtained.

The Z505S tube may be fed from similar circuits to those used for the 4 and 5 kc/s double pulse tubes, but the time constants of the driving circuit must be altered if advantage is to be taken of the greater maximum operating speed of the Z505S. The multivibrator pulse shaping circuit should have a time constant which will give an output pulse for driving the Z505S of not less than 6 μ sec duration. The time constant of the integrating circuit should also be reduced. The values of anode resistor, supply voltage, etc. required for the Z505S tube are

first counted in the normal way, but the counting process must be stopped whilst the digits are displayed by the indicator tubes.

4.3.13 The Z302C Tube

The Z302C tube is interesting because it can be used in circuits which require no amplifying device of any kind between successive counting tubes. Circuits employing this tube have an upper frequency limit of about 1 kc/s. Both positive and negative

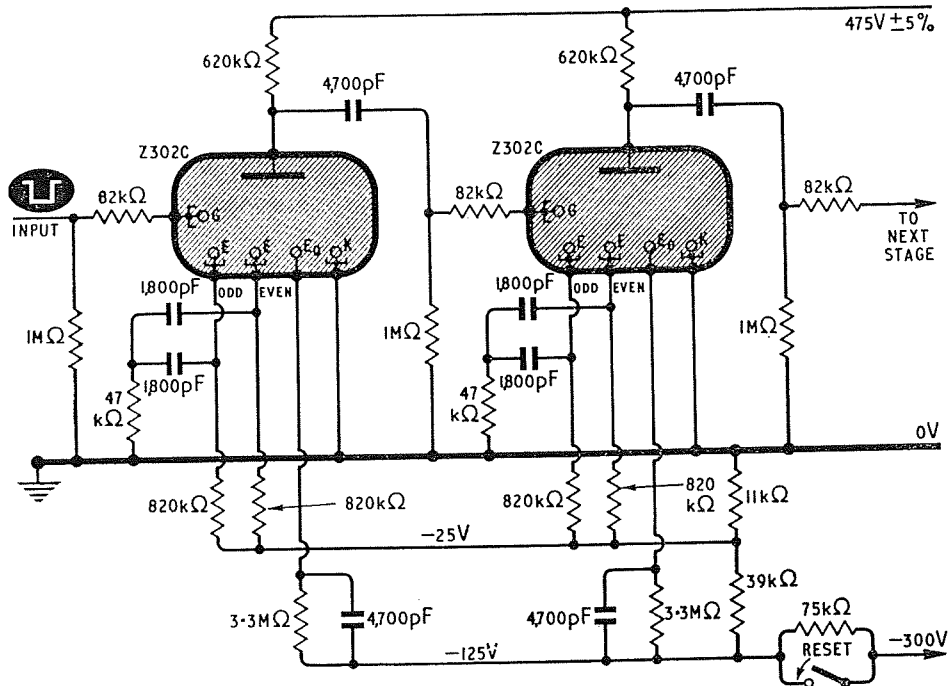

Fig. 4.18 A two decade circuit for the Z302C counter tube

shown in the table of Mullard tube data. It should be noted that a guide bias of +50 V is recommended.

A decade counting circuit using the Z505S has been developed in which 'In-line' numerical readout is provided by Z520M digital indicator tubes⁽¹¹⁾. The maximum counting speed is limited to about 40 kc/s by the transistor coupling circuits employed; these coupling circuits are also used to drive the digital indicator tubes. The operation of this type of circuit occurs in two phases. The input pulses are

supply voltages of fairly high value are required, although the current taken is small.

The Z302C has thirty equally spaced cathodes arranged in a circle around a common anode, two transfer electrodes being placed between each two main cathodes. The first guides are all connected together and are given the symbol G. The second guides are connected in two groups. All of the second guides which precede an odd numbered main cathode are joined together and are given the symbol E_{odd} , since the second guides in this type of

ELECTRONIC COUNTING CIRCUITS

tube are also known as extinguishing electrodes. The second guide which precedes the zero main cathode has a separate external connection, E_0 , but the remaining second guides which precede the even numbered main cathodes are connected to a common base pin, E_{even} . The main cathodes are joined to a common base pin, K.

The type of circuit which can be used with the tube is shown in Fig. 4.18.⁽¹²⁾ An input pulse of about 80 V in amplitude and about 300 μsec in duration is applied to all of the first guides. This causes the discharge to be transferred to a first guide. The guide current flows through a 1 M Ω resistor to earth and the potential of the first guides

therefore rises. When the input pulse terminates, the discharge is transferred to the second guide, since the latter is returned to a source of negative potential of about -25 V through an 820 k Ω resistor.

Whilst the discharge rests at the second guide, the 1,800 pF capacitor connected to the second guide charges and after a short time the second guide becomes sufficiently positive to cause the discharge to be transferred to the next main cathode. Any tendency the discharge may have to return to the first guide is opposed by the positive potential which the latter would acquire as soon as the first guide current commenced to flow through the 1 M Ω first guide resistor.

Table 4.1 BASIC DATA AND BASE CONNECTIONS FOR MULLARD/PHILIPS COLD CATHODE COUNTER AND SELECTOR TUBES

	Z302C	Z303C	Z502S	Z504S (ZM1070)	Z505S (ZM1060)
Maximum counting speed (kc/s)	1	4	4	5	50
Recommended anode current (mA)	0.4	0.34	0.34	0.34	0.80
Recommended H.T. supply (V)	475	475	475	475	525
Recommended anode load (Ω)	680K	820K	820K	820K	330K
Recommended guide bias (V)	—	+40	+40	+40	+50
Recommended pulse amplitude (V)	80	100	100	100	120
Recommended pulse duration (μsec)	350	75	75	75	6
Maintaining voltage (nominal)	190	191	191	195	260
Minimum H.T. supply voltage	400	350	400	375	400
Anode current					
Max. (mA)	0.55	0.55	0.55	0.525	1.00
Min. (mA)	—	0.25	0.25	0.25	0.60
Base	I.O.	I.O.	B12E	B13B	B13B
Escutcheon required (Mullard)	101065	101065	101064	101065	101065
Max. diameter (mm)	29.5	29.5	33	30	30
Max. seated height (mm)	87.5	87.5	70.5	36	36
Type of tube	10 way counter	10 way counter	10 way selector	10 way selector	10 way selector
<i>Base Connections</i>					
Pin 1	I.C.	K	K_0	K_5	K_5
Pin 2	E_{odd}	N.C.	K_9	K_4	K_4
Pin 3	E_{even}	G_1	K_8	K_3	K_3
Pin 4	G	A	K_7	G_2	G_2
Pin 5	K	G_2	K_6	K_2	K_2
Pin 6	E_0	N.C.	K_5	K_1	K_1
Pin 7	I.C.	K_0	K_4	K_0	K_0
Pin 8	A	N.C.	K_3	G_1	G_1
Pin 9	—	—	K_2	K_9	K_9
Pin 10	—	—	K_1	K_8	K_8
Pin 11	—	—	G_2	A	A
Pin 12	—	—	G_1	K_7	K_7
Pin 13	—	—	—	K_6	K_6
Base Cap	—	—	A	—	—

(The Z2302C tube is now obsolete)

When the discharge is resting at a main cathode, a small current will flow to the preceding second guide, since this is connected to the -25 V line. The flow of this small priming or probe current through the 820 k Ω second guide resistor ensures that the second guides are maintained at a positive potential which prevents the back transfer of the glow from the main cathode to the preceding second guide. Alternate second guides are joined together so that, although the second guide preceding the main cathode at which the discharge is resting is at a positive potential with respect to the -25 V line, the succeeding second guide (which is taking virtually no current, as it is not strongly primed) is at the potential of the -25 V line; this, therefore, enables the discharge to move from the first to the second guide at the end of the input pulse.

The zero second guide, E_0 , is returned to a negative supply of about -125 V via a 3.3 M Ω resistor in parallel with a capacitor. When the discharge first reaches E_0 , the potential of this cathode is maintained at about -125 V whilst the $4,700$ pF capacitor is charging. A larger current, therefore, flows to the zero second guide than flows when the discharge rests at any other cathode. As the capacitor in the cathode circuit of the zero second guide charges, however, the guide becomes more positive owing to the flow of current through the 3.3 M Ω resistor. The discharge, therefore, moves to the zero main cathode.

The large current which flows to the zero second guide for a short time produces a relatively large voltage pulse across the anode resistor and this pulse can be used to operate the succeeding decade directly through a resistance-capacitance coupling, as it is of a suitable amplitude and of the correct polarity.

The reset switch can be used to apply momentarily a negative potential of about 300 V to the zero cathode of the counter tubes. The discharge can thus be transferred to the zero cathodes of all of the tubes in the scaler.

Although the Z302C is no longer in current production, the above details have been included since it is felt that the principle of operation of this tube is of interest.

4.4. ERICSSON TUBES AND THEIR CIRCUITS

Double Pulse Decade Tubes:

- 4 kc/s Counter tubes: GC10B; GC10B/S (CV2271).
- 4 kc/s Counter specially processed for long life: GC10B/L (CV6044).
- 4 kc/s Computing tube with intermediate outputs: GC10/4B (CV1739).
- 4 kc/s Computing tube specially processed for long life: GC10/4B/L (CV6100).
- 4 kc/s Selector tube: GS10C/S (CV2325).
- 5 kc/s Selector tube: GS10H (with routing guides; the smallest and cheapest dekatron.)
- 10 kc/s Selector tubes: GS10D and GS10E.
- 1 kc/s Low voltage dekatron: GS10J.
- 10 kc/s Tubes with auxiliary anodes for direct operation of digitrons
Counter: GCA10G
Selector: GSA10G.

Double Pulse 12 way Tubes:

- 4 kc/s 12 way Computing tube with intermediate outputs: GC12/4B.
- 4 kc/s 12 way Selector tube: GS12D.

Single Pulse 20 kc/s Decade tube: GC10D (CV5143).

Tubes for Maintenance Only:

- 1 kc/s GC10/2P (miniature)
- 4 kc/s GS12C (soldered contacts on phenolic tube)
- 10 kc/s GS10G (with routing guides)
- 10 kc/s GS10K (decade selector with three sets of guides for high voltage or high current output).

(Ericsson tubes are now being manufactured by Hivac Ltd.)

Ericsson gas filled polycathode counter and selector tubes are known by the registered trade mark of Dekatron. The basic data for these tubes is shown in Table 4.4. All of the current types, except for the single pulse GC10D, operate on the double pulse principle discussed in Section 4.2, but there are a large number of different types from which the circuit designer can choose.

4.4.1 Circuits for Double Pulse Tubes

The same basic type of circuit can be used with any of the simple 4 kc/s double pulse Dekatrons, but the optimum values of some of the components depend on the particular type of tube chosen; these values are shown on the circuit diagrams. The circuits of Figs. 4.19 to 4.23 inclusive can be used with any of the following tubes: GC10B, GC10B/S, GC10B/L, GC10/4B, GC10/4B/L, GC12/4B, GS10C/S, GS10H and GS12D.

4.4.2 Dekatron Coupling Circuits⁽¹³⁾

The circuit of Fig. 4.19 shows how a GTE175M trigger tube, *V*₂, can be used for coupling two 4kc/s double pulse Dekatrons. When the discharge in the first counting tube, *V*₁, moves to the zero cathode, the resulting positive going pulse from this cathode is applied to the trigger electrode of *V*₂ via the capacitor *C*₁. This pulse, when added to the bias applied to the trigger electrode, causes the trigger tube to ignite. The flow of anode current in the trigger tube causes the anode potential of the tube to fall, and this fall is fed to the first guides of the succeeding counter tube, *V*₃, via a capacitor. The second guide pulse is obtained from a tapping on the anode load resistor of the trigger tube.

The number of 'carries' per second is limited to a maximum of about 500 by the characteristics of the trigger tube, but even if the preceding Dekatron, *V*₁, is operating at its maximum speed of 4 kc/s, the trigger tube will not be required to handle more than 400 pulses per second. Although Fig. 4.19

requires no heater wiring, a -100 V supply is required for the priming cathodes of the GTE175M tube.

A similar circuit using a hard valve for coupling two Dekatrons is shown in Fig. 4.20. The valve is used to amplify and invert the phase of the positive going signal from the cathode of the first Dekatron. The resulting negative going pulse is fed to the first guides of *V*₃ and, through an integrating circuit, to the second guides.

If a selector tube is used with a resistor in each of the main cathode leads, the current passing through the tube will be less than in a counter tube of similar construction in which nine of the main cathodes are directly earthed. In order to overcome this change of anode current, it is recommended that, when a 4 kc/s selector tube is used with a 150 kΩ resistor in each cathode circuit, the anode resistor should be reduced from the value of 820 kΩ recommended for 4 kc/s counters to 680 kΩ so that the total (anode+cathode) resistance remains almost unchanged. Thus the anode current is kept

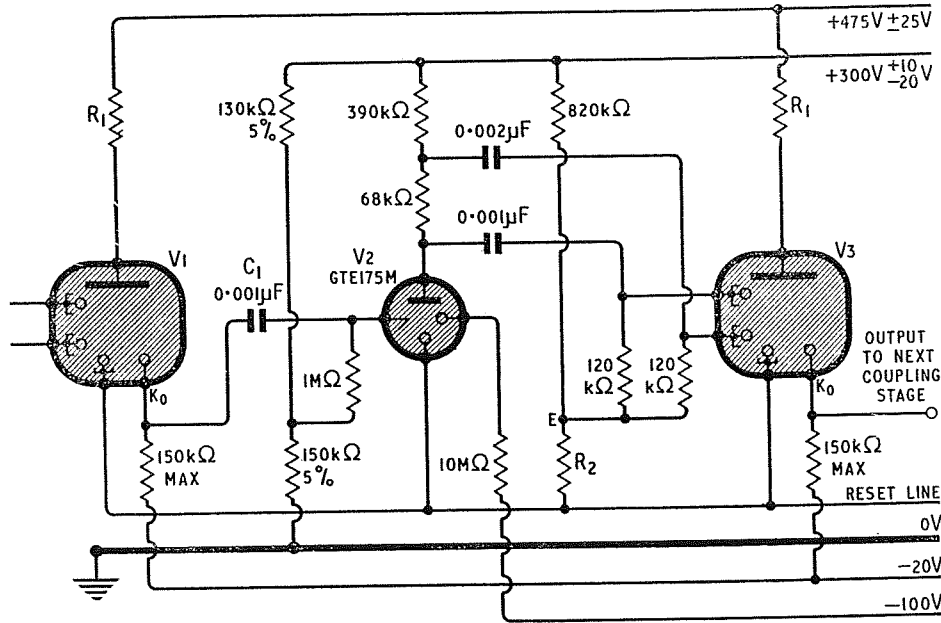

Fig. 4.19 A trigger tube coupling circuit for 4 kc/s Dekatrons

<i>V</i> ₁ , <i>V</i> ₃	Counters	Selectors
<i>R</i> ₁	820 kΩ	680 kΩ
<i>R</i> ₂	39 kΩ	47 kΩ

at its optimum value if the recommended H.T. supply potential of 475 ±25 V is employed.

The maximum positive potential of the output cathode of a counter tube is about +18 V, but owing to the smaller value of the anode resistor used in selector tube circuits, the potential of the output

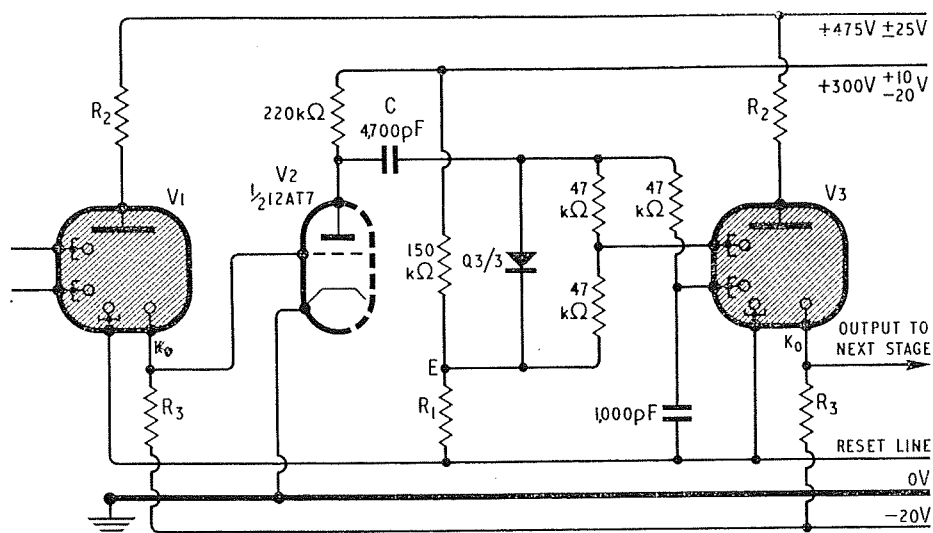

Fig. 4.20 A valve coupling circuit for 4 kc/s Dekatrons

V_1, V_3	Counters	GS10C	GS12D
R_1	10 k Ω	22 k Ω	22 k Ω
R_2	820 k Ω	680 k Ω	910 k Ω
R_3	150 k Ω	150 k Ω	270 k Ω
E	+18 V	+36 V	+36 V

cathode of a selector tube may reach +36 V. The positive guide bias should not be less than the maximum potential reached by any main cathode (except for sine wave inputs) and, therefore, a larger bias is recommended for selector tubes than for counter tubes. Suitable values for the potential divider resistors from which the guide bias may be obtained are shown in Figs. 4.19 to 4.21 and also in Fig. 4.23. The guide bias is the potential at the point marked 'E' in these circuits.

In the case of the trigger tube coupling circuit of Fig. 4.19, the capacitor C_1 should be increased to 0.01 μ F if the input to V_1 is a sine wave; otherwise the pulses from V_1 might not be steep enough to pass through C_1 to the trigger tube V_2 .

4.4.3 Input Circuit for 4 kc/s Dekatrons⁽¹³⁾

A suitable circuit for providing the twin pulses of the correct shape for the first counter tube of Fig. 4.19 or 4.20 is shown in Fig. 4.21. A short positive pulse of an amplitude not less than 20 V may be used to trigger the monostable multivibrator V_1 .

In the quiescent condition V_1b conducts owing to the fact that its grid is connected to the positive

H.T. line via a 390 k Ω resistor. V_1a is normally cut off by the voltage present across the common cathode resistor resulting from the flow of anode current in V_1b . The input pulse causes V_1a to conduct and the resultant negative pulse at the anode of this valve is fed to the cathode follower, V_2 . The output at the cathode of V_2 is, of course, in phase with the grid potential of this valve and is fed to the first guides of the Dekatron, V_3 . The same pulse is fed through an integrating circuit to the second guides.

The Q3/3 diode in the guide circuits of Figs. 4.20, 4.21 and 4.23 prevents the guides from becoming more positive than the guide bias supply point, E. The GEX55/1 diode in Fig. 4.21 prevents the negative going trailing edge of the input pulse from reaching the grid of V_1a where it might cause the multivibrator to return prematurely to its quiescent state.

Sine Wave Input⁽¹³⁾

If the input consists of sine waves, the circuit shown in Fig. 4.22 may be used to count the peaks. The circuit is very similar to the Mullard circuit of Fig. 4.16 and suffers from the same disadvantage that the correct phase relationship of the pulses at the

ELECTRONIC COUNTING CIRCUITS

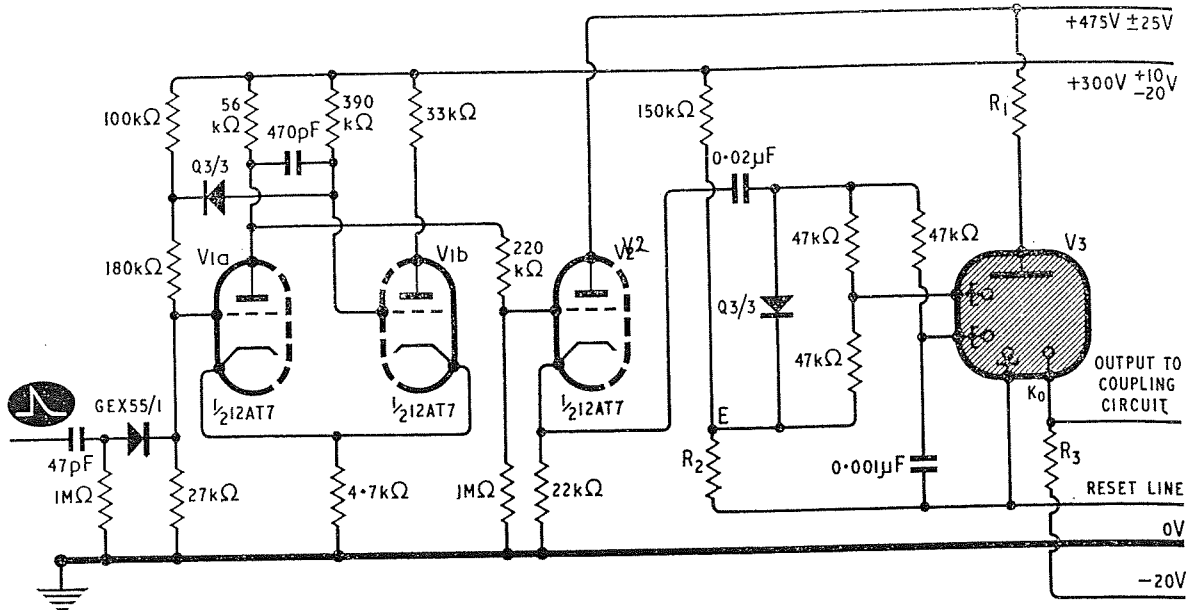

V_3	Counters	Selectors
R_1	820 k Ω	680 k Ω
R_2	10 k Ω	22 k Ω
R_3	150 k Ω (max.)	150 k Ω (max.)
E	+18 V	+36 V

Fig. 4.21 An input circuit for 4 kc/s Dekatrons

two guides is not established until a few cycles have elapsed. If it is necessary to count every sine wave peak from the moment that the signal is applied to the circuit, the circuit of Fig. 4.23 may be used. The 12AU7 acts as a Schmitt trigger circuit. Each negative peak of the input sine wave causes $V1a$ to be cut off and $V1b$ to conduct. The negative pulses at the anode of $V1b$ are fed to the first guides of $V2$.

Reset

The reset lines shown in the circuits in this section should be connected to earth through a resistor which is shorted out by a switch or a relay except during the actual moment when the resetting operation is carried out. The output cathodes of the Dekatrons and the cathodes of the valves in the input and the coupling circuits are returned to separate H.T. negative lines.

If the switch or relay which connects the reset line to earth is opened, the current from the counting tubes flows through the resistor to earth and

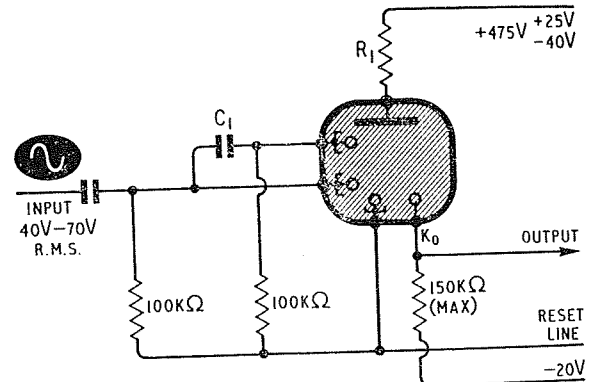

Input frequency	4 kc/s	2 kc/s	1 kc/s	500 c/s
C_1	680 pF	0.002 μ F	0.005 μ F	0.01 μ F

Input frequency	200 c/s	100 c/s	50 c/s
C_1	0.02 μ F	0.05 μ F	0.1 μ F

	Counters	Selectors
R_1	820 k Ω	680 k Ω

Fig. 4.22 A circuit for feeding 4 kc/s Dekatrons from a sine wave input

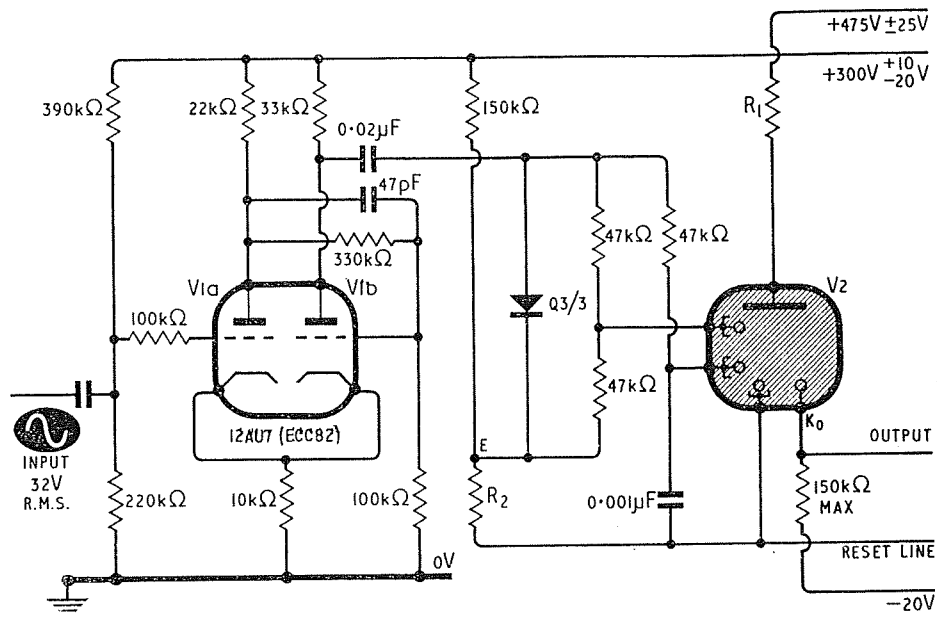

Fig. 4.23 A Schmitt trigger circuit for shaping sine wave input signals

	Counters	Selectors
R_1	820 k Ω	680 k Ω
R_2	10 k Ω	22 k Ω
E	+18 V	+36 V

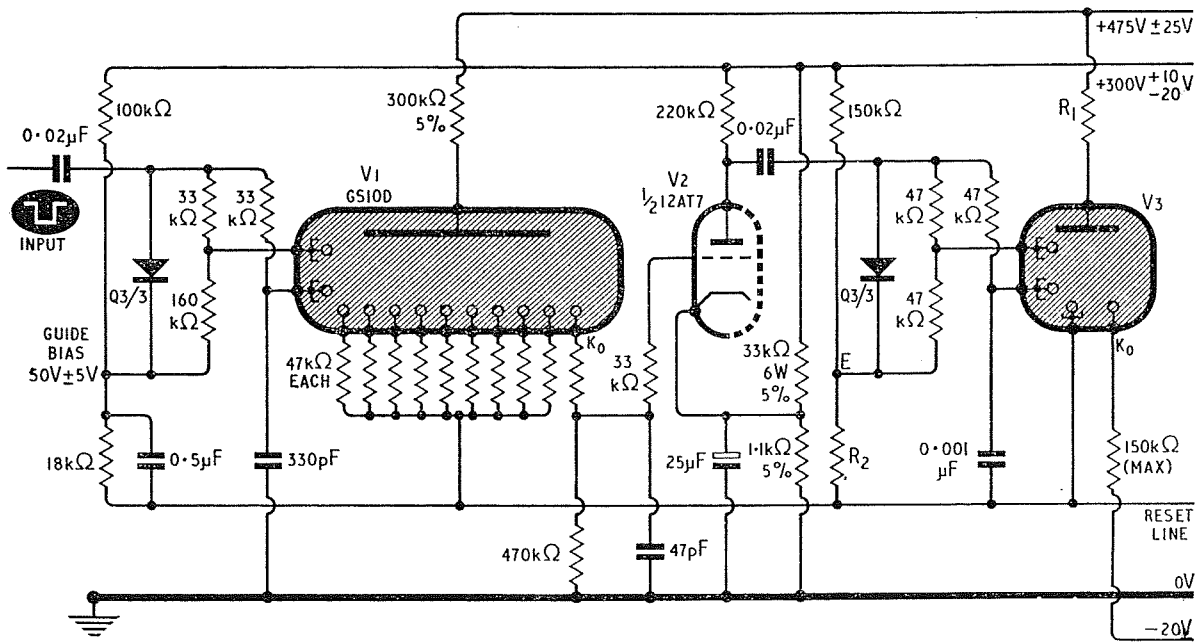

Fig. 4.24 A circuit for coupling the GS10D to a 4 kc/s Dekatron

	Counters	Selectors
R_1	820 k Ω	680 k Ω
R_2	10 k Ω	22 k Ω
E	+18 V	+36 V

ELECTRONIC COUNTING CIRCUITS

the potential of all of the main cathodes except the zero cathode of each Dekatron is raised so that the discharge in each tube moves to the zero cathode.

The value of the reset resistor should be chosen so that the potential of the reset line increases by about 100 V during the resetting operation. The value of this resistor should be varied according to the number of decades used.

4.4.4 The GS10D Tube ⁽¹³⁾

The GS10D double pulse selector tube can be used to count impulses at frequencies up to 10 kc/s, but it can count sine wave peaks at up to 20 kc/s. The operating principle of the GS10D circuits is the same as that of the 4 kc/s double pulse tubes, but the input pulses can be shorter in duration. A typical circuit for the GS10D is shown in Fig. 4.24 in which it is coupled to the succeeding 4 kc/s tube by a valve amplifier. The grid and cathode of the valve are also used as a limiting diode for the GS10D output cathode voltage.

The GS10D has a higher anode current and requires a rather higher guide bias than the 4 kc/s tubes. It can be seen from Fig. 4.24 that the integrating circuit time constant in the GS10D second guide circuit is much less than in the second guide circuit of the succeeding 4 kc/s tube, V_3 .

The impulses to the circuit of Fig. 4.24 should have an amplitude of 145 ± 15 V and a duration of $33 \mu\text{sec}$ ($\pm 20\%$). The slope of the leading edge of the negative going input pulse should not exceed $150 \text{ V}/\mu\text{sec}$. The circuit may be fed from a circuit identical to the input section of Fig. 4.21, but the capacitor connecting the grid of V_{1b} in Fig. 4.21 to the anode of V_{1a} should be reduced from 470 pF to about 150 pF so that the desired pulse length of about $33 \mu\text{sec}$ is obtained.

If the maximum possible speed of operation is to be obtained from the GS10D, it is essential to reduce the effect of stray capacitance from the anode to ground to a minimum. The anode resistor should be wired not more than $\frac{1}{4}$ in. (5 mm) from the anode tag of the tube holder.

The characteristics of the GS10E are rather similar to those of the GS10D and both tubes can be used in similar circuits. The maximum operating

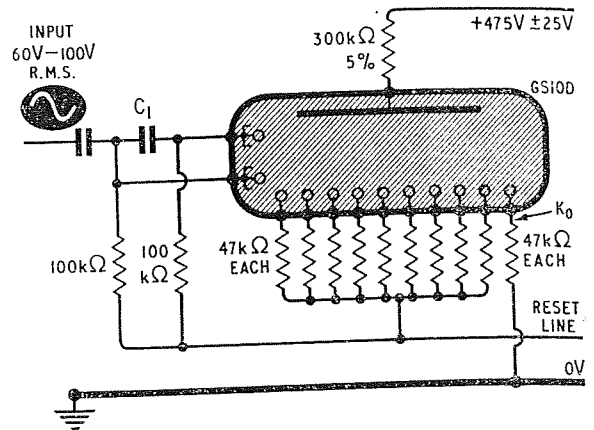

Input frequency	20 kc/s	15 kc/s	10 kc/s	5 kc/s	2 kc/s
C_1	270 pF	330 pF	470 pF	680 pF	0.002 μF
Input frequency	1 kc/s	500 c/s	200 c/s	100 c/s	50 c/s
C_1	0.005 μF	0.01 μF	0.02 μF	0.05 μF	0.1 μF

Fig. 4.25 A sine wave input circuit for the GS10D

speed quoted for the GS10E is 10 kc/s both in the case of rectangular input pulses and in the case of sine wave input.

The GS10D may be used in the circuit of Fig. 4.25 to count the peaks of sine waves at frequencies up to 20 kc/s. The value of C_1 should be varied as shown in Fig. 4.25 for different operating frequencies. When the input is first applied, the correct phase relationship of the guide voltages will not be established for a short time and a few of the first peaks of the input wave will not be counted.

4.4.5 Transistor Drive circuits

The circuit of Fig. 4.26 shows how a transistor may be employed to drive a Dekatron⁽¹³⁾. The input pulses should have an amplitude of between 5 and 12 V and should be negative going; their duration should not be less than $10 \mu\text{sec}$. The transistor is employed in a blocking oscillator circuit so that a single transistor can be used and so that a voltage large enough to drive the Dekatron can be taken from the secondary winding of the blocking oscillator transformer. A cheap low voltage transistor can be used, since the voltage applied to it is relatively small.

MULTI-ELECTRODE GAS FILLED TUBES AND THEIR CIRCUITS

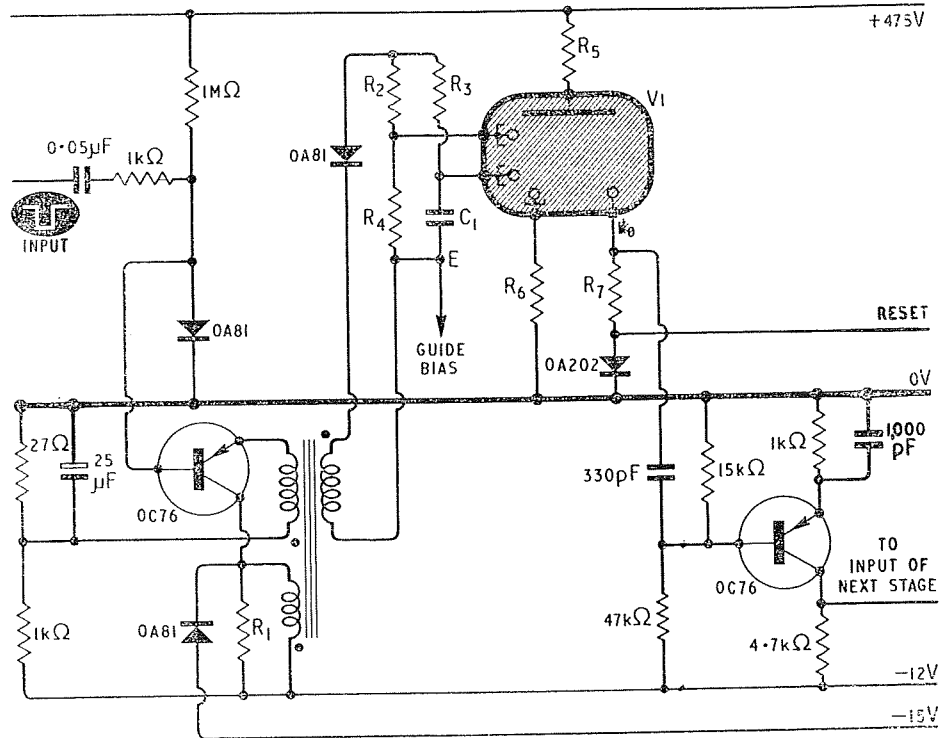

Transformer details for 4 kc/s. Dekatrons

5/16 in stack of 0.008 in mu-metal laminations RCL191, type 421. Collector winding 100 turns, emitter winding 20 turns, output winding 906 turns

Transformer details for 10 kc/s Dekatrons

1/4 in stack of 0.004 in mu-metal lamination RCL191, type 450. Collector winding 45 turns, emitter winding 7 turns, output winding 515 turns.

Type of tube	V_1	R_1	R_2	R_3	R_4	R_5	R_6, R_7	C_1	Guide Bias
4 kc/s Dekatrons	GC10B,	4.7 kΩ	47 kΩ	47 kΩ	47 kΩ	820 kΩ	150 kΩ max	1000 pF	+18 V
	GS10C	4.7 kΩ	47 kΩ	47 kΩ	47 kΩ	680 kΩ	150 kΩ max	1000 pF	+36 V
	GS12D	4.7 kΩ	47 kΩ	47 kΩ	47 kΩ	680 kΩ	270 kΩ max	1000 pF	+36 V
10 kc/s Dekatrons	GS10D	Omit	33 kΩ	160 kΩ	160 kΩ	300 kΩ	47 kΩ max	330 pF	+50 V
	GS10E	Omit	33 kΩ	33 kΩ	16 kΩ	240 kΩ	39 kΩ max	330 pF	+50 pF

Fig. 4.26 A transistor drive and coupling circuit for Dekatrons

The circuit will provide an output pulse which is capable of driving a similar succeeding decade directly.

The type of transformer, the guide bias and the values of some of the components should be chosen according to the type of Dekatron which is to be used. Full details are given in Fig. 4.26. Other transistor drive circuits have been published. ^(14, 15)

4.4.6. The Computing Tubes ^(13, 16)

The decade computing tube GC10/4B is of exactly the same construction as the GC10B counting

tube except that four of its main cathodes are brought out to separate base pins whereas in the GC10B only one of the main cathodes has a separate base pin. The GC10/4B/L is a long life version of the GC10/4B, whilst the GC12/4B has twelve main cathodes, four of which are brought out to separate base pins.

The computing tubes can be used in multidecade circuits for addition or subtraction where the direction sensing circuits require at least one output pulse between the digits zero and nine. The four output cathodes which are connected to separate base pins are designated *A, B, C* and *D*. The remain-

4.4.7 The GS10J

The GS10J is a low voltage Dekatron which has a striking voltage of 150 V. The recommended H.T. supply voltage is 200 V, but the maximum operating frequency is 1 kc/s. The pulses fed to the guides should be of about 24 V in amplitude and 300 μ sec in duration with a 10 μ sec overlap.

The GS10J may be used in circuits similar to those designed for 4 kc/s tubes, but the time constant of the integrating circuit feeding the second guides should be increased by a factor of about four and the input pulses must be about four times as long as those recommended for 4 kc/s tubes. The anode resistor should be 330 k Ω and the maximum output voltage which can be obtained from the tube is about 3 V across 3.3 k Ω cathode resistors.

4.4.8 Tubes with Routing Guides for Bidirectional Counting^(13, 17)

In the GS10J, GS10H, GS10G, GCA10G and GSA10G tubes the first guide electrode following the ninth main cathode and the second guide elec-

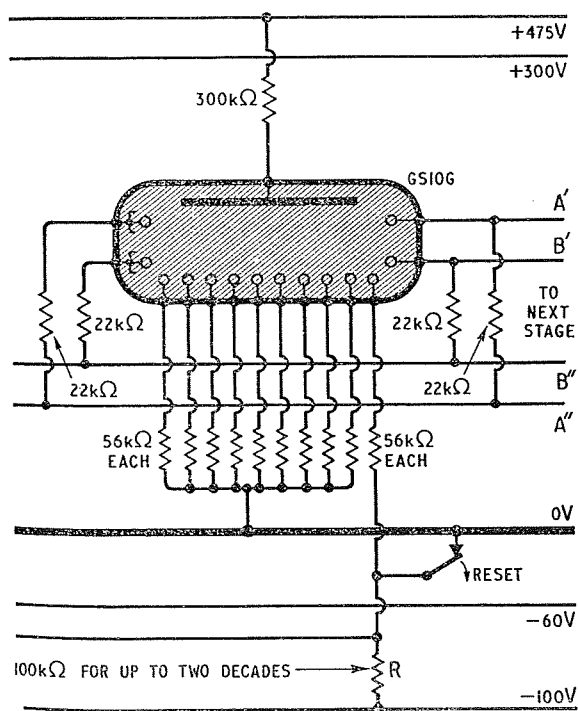

reversible counting circuit

trode preceding the zero cathode are each brought out to separate base pins. These electrodes are known as routing guides and enable the tubes to be used in multidecade bidirectional counting circuits. The conventional symbol for Dekatrons with access to routing guides is as shown in the circuit of Fig. 4.27, the routing guides being the two electrodes on the right hand side of the tube symbol.

If a scaler is adding pulses, a 'carry' pulse must be fed to the succeeding decade when the discharge arrives at the zero cathode. Similarly, if the input pulses are being subtracted from the total count, a negative carry pulse must be passed to the next decade when the discharge arrives at the ninth cathode. If the same circuit is to be used for both forward and reverse counting, it is not sufficient merely to insert resistors in the zero and ninth cathode circuits in order to obtain the carry pulses. The carry pulses must also be gated according to the direction of counting.

In the bidirectional counting circuit of Fig. 4.27, the first guide pulses are applied to nine of the first guide electrodes and also, via a resistor, to the first routing guide. Similarly, the second routing guide is connected via resistors to the other second guides. When the discharge rests momentarily at either of the routing guides, a potential difference will be present across the routing guide series resistor.

If the discharge is moving forwards, it will first rest momentarily at the first routing guide. The voltage across this guide resistor will be amplified by the double triode stage V_A and a pulse will be fed to the first guides of the succeeding Dekatron. A fraction of a second later the discharge in the first Dekatron will rest momentarily at the second routing guide and the voltage across the guide resistor will be amplified by V_B so that a pulse is fed to the second guides of the next decade. Since the second Dekatron receives a pulse at its first guides before the pulse arrives at its second guides, the discharge will move one position in a clockwise direction.

If the first Dekatron had been counting in reverse, however, the discharge would have rested at its second routing guide before coming to its first routing guide. The resulting pulses would have been amplified by V_B and V_A respectively and passed

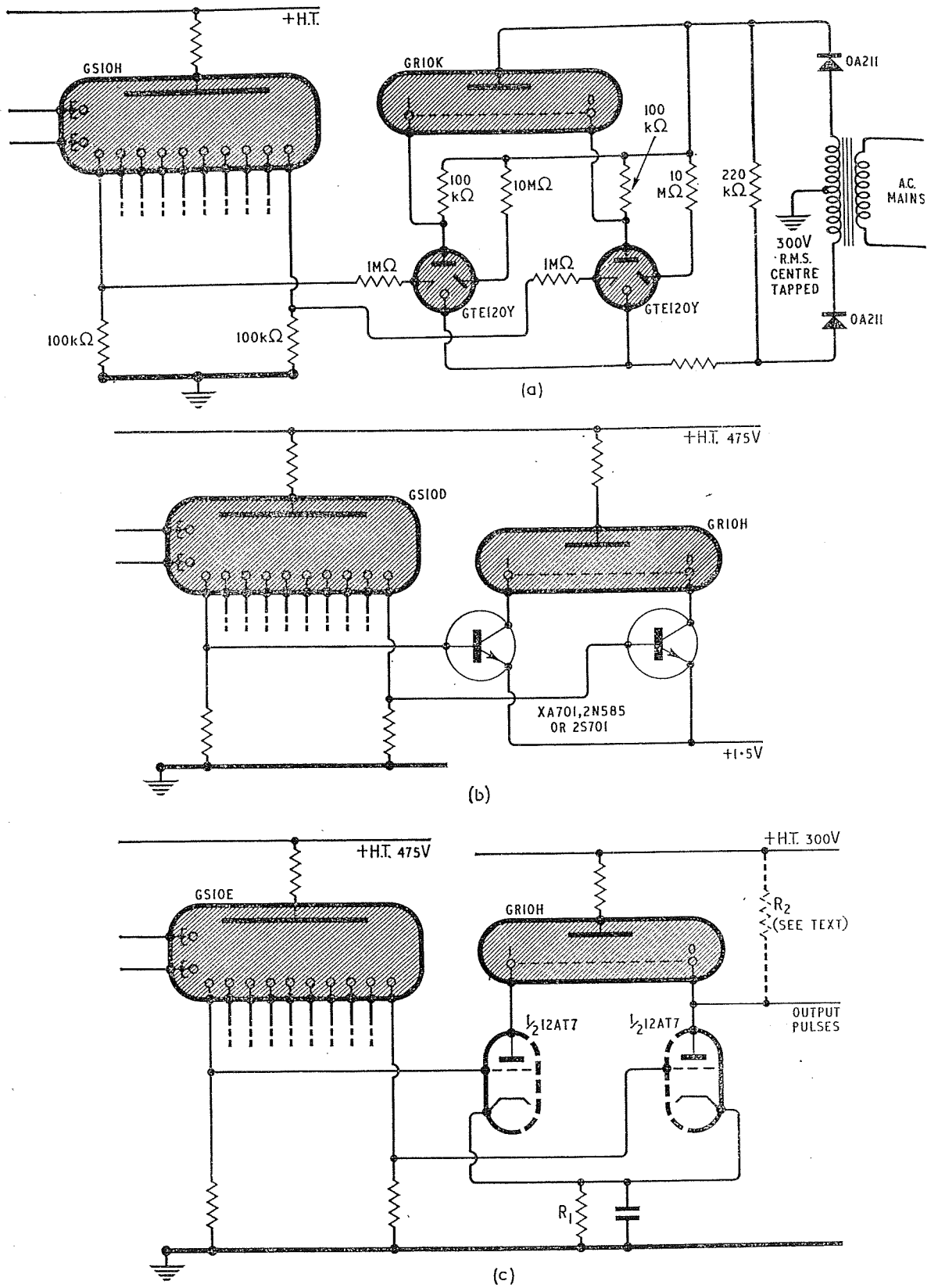

Fig. 4.28 Digitron readout from Dekatron circuits using (a) trigger tube, (b) transistor and (c) valve coupling

to the second Dekatron; the second guide electrodes of this Dekatron would, therefore, have received a pulse before the first guide electrodes and the tube would count in reverse (or subtract).

It can be seen that the grid and cathode of the first stage of each coupling amplifier are connected directly across the corresponding routing guide resistor. The second stages of the coupling amplifiers are cathode followers which provide a drive of low impedance for the succeeding Dekatron and also provide a means by which a suitable guide bias may be obtained. The coupling amplifiers V_A and V_B are d.c. coupled throughout.

A negative going pulse of about 100 V in amplitude and 30 μ sec in duration fed into the 'A' input followed by a similar and slightly overlapping pulse to the 'B' input will cause the count to increase by one unit, whereas two similar pulses fed first into the 'B' input and then into the 'A' input respectively will reduce the total count by one unit. The switching of the second decade takes place simultaneously with the switching of the first decade and the whole process is, therefore, very rapid.

The resistor R in the resetting circuit of Fig. 4.27 may be 100 k Ω for up to two decades, but its value should be reduced in proportion to the number of decades if more than two are employed.

4.4.9 Digital Indication from Dekatron Circuits

Dekatron tubes are self indicating devices, but the state of the count is shown merely as the position of a point of light. If readout in the form of actual digits is required, it is necessary to use the Dekatron to control the operation of a numerical indicator tube (see Chapter 10). Ericsson Numerical Indicator Tubes are known as 'Digitrons'.

Two main requirements must be satisfied for the operation of Digitrons⁽¹⁸⁾. The current passing through the Digitron must be great enough for the whole of the cathode to be covered by the glow. The second requirement is that all of the Digitron cathodes which are not glowing at any given time must be at a positive potential or pre-bias of about 40 V which will prevent any discharge from taking place to them.

Circuits such as those shown in Fig. 4.28 have been developed which enable Digitron readout to be obtained from standard type Dekatrons⁽¹⁸⁻²¹⁾, but since the normal Dekatron does not pass enough current to operate a Digitron, some form of amplifying device must be used in this type of circuit.

The circuit of Fig. 4.28(a) was developed in order to provide a simple means of adding digital readout to an existing Dekatron scaler without altering the existing circuitry. GTE120Y miniature wire ended trigger tubes are used as amplifying devices. This type of tube has a sufficiently stable trigger characteristic to enable the circuit to operate from an input differential of 12 V developed across the cathode resistors of a Dekatron selector tube⁽²⁰⁾.

The power supply to the Digitron and trigger tubes is half wave rectified unsmoothed a.c. The tubes will, therefore, be extinguished once per cycle of the mains frequency. When one of the trigger tubes has ignited, the fall in potential across the resistor in the trigger tube cathode circuit ensures that no other tube can ignite. The peak negative voltage applied to the trigger tube cathodes is well in excess of the trigger to cathode striking potential of 120 V and, therefore, one trigger tube will always strike. The discharge then spreads to the anode and this prevents other tubes from striking by the mechanism discussed.

The time taken for the tube to strike decreases rapidly as the trigger to cathode voltage increases above the required minimum. An over-voltage of one volt applied to a tube is sufficient to ensure that this tube will strike first, but in order to allow for the spread of trigger tube striking voltages from tube to tube, it is necessary to apply about 12 V from the cathode of the Dekatron at which the discharge is resting.

The anode current of the trigger tube which has been ignited causes a potential drop across the trigger tube anode resistor and this is applied to the corresponding cathode of the Digitron which, therefore, glows.

An alternative circuit employing ten transistors per decade is shown in Fig. 4.28(b)^(20, 21). The transistors must be used in the grounded emitter configuration, since they are required to give a cur-

rent gain. The output voltage from the Dekatron is positive going and this voltage must be used to render the transistors conducting. NPN transistors are therefore required. When a transistor conducts, a current flows from the Digitron cathode to the transistor collector and the Digitron cathode glows.

The non-glowing Digitron cathodes will have a potential which is dependent on the leakage current of the transistors used. The current flowing from these cathodes must not exceed about $100 \mu\text{A}$ per cathode or spurious glows may occur which make readout more difficult. The non-glowing cathodes will be about 40 V positive with respect to the glowing cathode when this current is passing and, therefore, fairly high voltage transistors should be used. These tend to be fairly expensive and hence the trigger tube circuit may be preferred. The GR10G is the only current type of Digitron tube which is not suitable for operation from commercially available transistors, since the degree of ionisation coupling in this tube necessitates much higher values of pre-bias voltage⁽²²⁾.

A third alternative is the circuit of Fig. 4.28(c) in which five double triodes per decade are used as amplifiers⁽²⁰⁾. The flow of the anode current of one triode through the common cathode resistor, R_1 , biases all of the other nine triodes to cut off. If a positive voltage is fed from a cathode of the Dekatron to the grid of the corresponding triode, the latter will conduct and the triode which was previously conducting will be cut off. The Digitron cathode supplying the current to the conducting triode will glow. The value of the resistor R_1 determines the Digitron current.

Negative going pulses may be obtained from a Digitron cathode (e.g. for the purpose of operating the succeeding decade), but in this case an extra resistor, R_2 in Fig. 4.28(c), should be included so that the leading edge of the pulse is not affected by the ionisation time of the Digitron.

Although the valve circuit requires no modifications to the Dekatron circuits, it has the disadvantage of being rather bulky.

4.4.10 Dekatrons for Digitron Operation

Two Dekatrons have been developed which contain ten additional electrodes in the form of an inner

ring between the main anode and the cathode-guide ring of electrodes. These additional electrodes are known as auxiliary anodes and can be seen in the photograph of the GCA10G and GSA10G. Each auxiliary anode is situated radially between a main cathode and the main anode. Dekatrons containing these additional electrodes may be used without any coupling amplifier for the direct operation of Digitron tubes and thus enable the extra cost and complexity of the ten amplifiers per decade shown in the circuits of Fig. 4.28 to be eliminated.

The only difference between the GCA10G and the GSA10G is that the former is a counter tube whilst the latter is a selector tube with a separate connection to each of the ten main cathodes. In both tubes the routing guides are brought out to separate external connections so that they can be used for bidirectional counting. Each of the ten auxiliary anodes is also connected to a separate base pin.

The total current passing to a glowing main cathode is shared between the main anode and the auxiliary anode which is nearest to the glowing cathode. The recommended main anode operating current is 0.62 mA and the auxiliary anode current 2.0 mA. The Digitron cathodes are connected directly to the auxiliary anodes, but a bias supply network also feeds the auxiliary anodes.

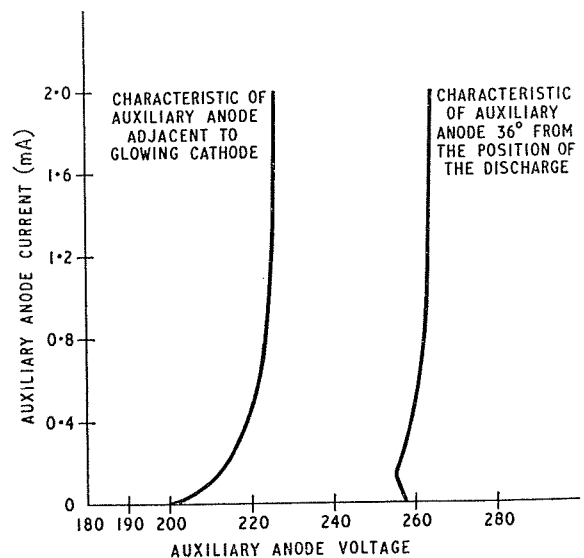

Fig. 4.29 Auxiliary anode characteristics

MULTI-ELECTRODE GAS FILLED TUBES AND THEIR CIRCUITS

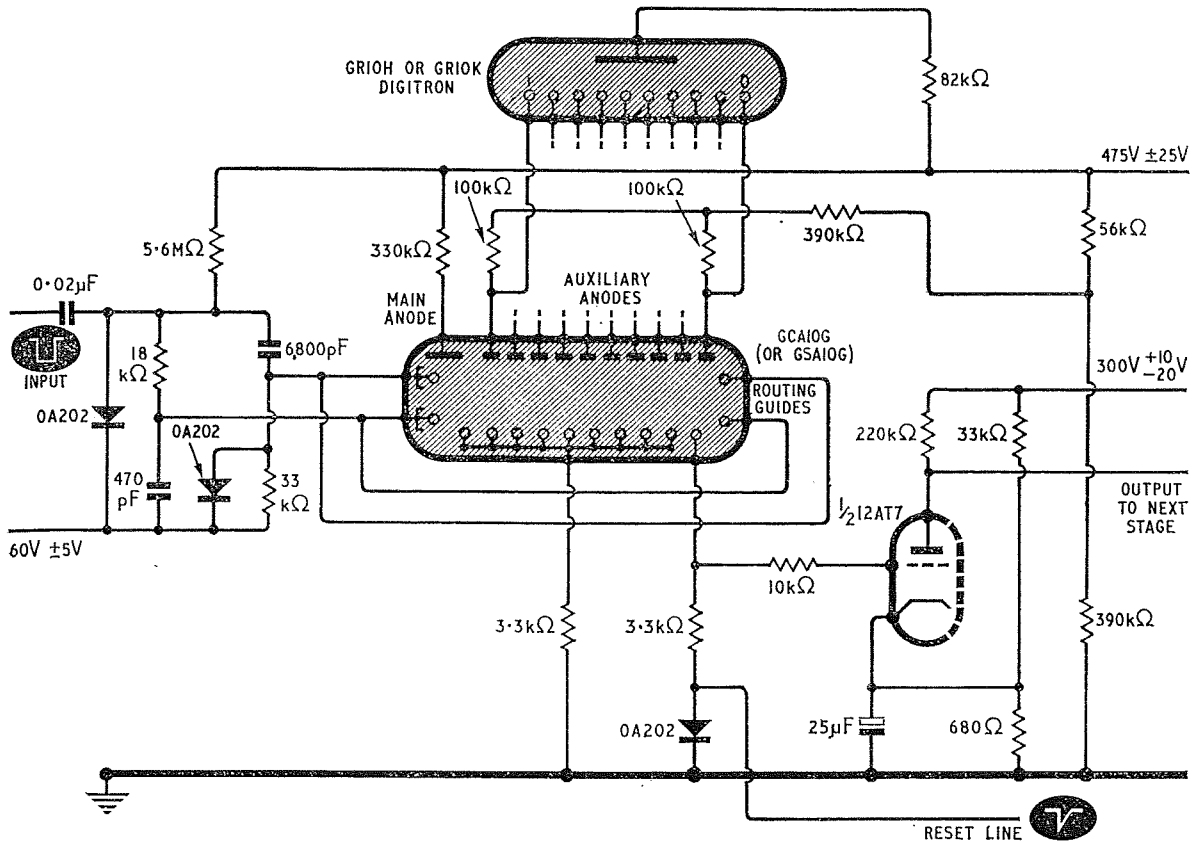

Fig. 4.30 The direct operation of a Digitron from a GCA10G tube

The extent to which the auxiliary anodes are primed depends on their distance from the glowing main cathode. It can be seen from the auxiliary anode characteristics of Fig. 4.29 that the auxiliary anode radially in line with the glowing cathode will conduct at an applied potential of about 40 V less than is required to cause one of the other adjacent auxiliary anodes to conduct. The characteristic is very steep, so the output impedance of the auxiliary anode circuit is very low. The normal operating point is about 225 V at 2 mA.

The fact that a potential of about 40 V can exist between the conducting auxiliary anode and an adjacent auxiliary anode before any appreciable conduction takes place to the latter enables the required pre-bias for the Digitron to be obtained.

A typical circuit for the operation of a Digitron from a GCA10G or a GSA10G is shown in Fig.

4.30⁽¹⁸⁾. A 100 kΩ resistor is connected to each auxiliary anode and the junction of the upper ends of these resistors is returned to a source of +430 V via a 390 kΩ resistor. These values are chosen so that the potential across the 100 kΩ resistor connected to the conducting auxiliary anode will be about equal to the required pre-bias for the Digitron of 40 V. This, therefore, ensures that a negligible current flows to the non-glowing cathodes of the Digitron.

The current passing to the auxiliary anode may be varied by changing the value of the Digitron anode resistor, whilst the Dekatron main anode current can be varied by changing the value of its main anode resistor. The two currents are more or less independent of each other.

The GCA10G can provide a pulse of about +10 V from its output cathode, whereas the GSA10G can provide a pulse of this value from

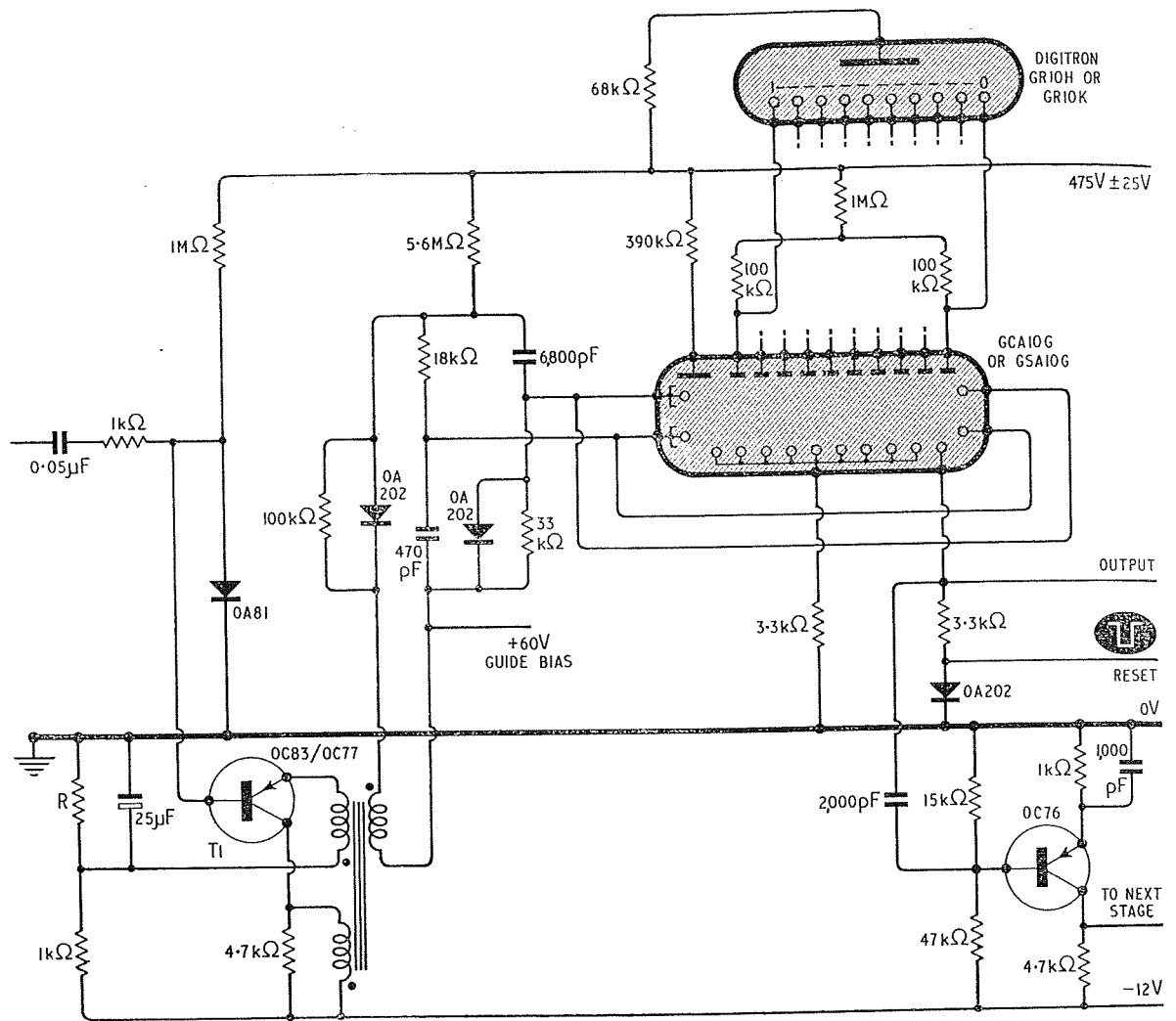

TRANSFORMER DETAILS

516 in stack of 0.008 in mu-metal laminations RCL 191, type 421	
collector winding	120 turns
emitter winding	50 turns
output winding	1500 turns

Max. freq.	T_1	R	Input Pulses	
			V_{min}	t_{min}
2 kc/s	0C77	27 Ω	5	10 μ sec
5 kc/s	0C83	12 Ω	10	20 μ sec

Fig. 4.31 Transistor drive and coupling circuits for the GCA10G or GSA10G

any of its main cathodes. In addition either tube can supply a negative going pulse of about 40 V amplitude from any of the auxiliary anodes.

The input pulses to the circuit of Fig. 4.30 should have an amplitude of between 140 and 160 V and should be between 90 and 110 μ sec in length. The circuit of Fig. 4.30 is designed for forward counting only and the first routing guide is connected to the other first guides. Similarly, the second routing guide is connected to the other second guides.

Owing to the relatively high cathode current of the Dekatrons which employ auxiliary anodes, the input circuit techniques which are used are somewhat different from those employed with other types of Dekatron. It is important to note that the Digitron is an integral part of the system and its associated circuitry cannot be modified without affecting the Dekatron drive conditions.

The circuit of Fig. 4.31 shows how transistors may be used in the input and coupling circuits of the auxiliary anode tubes^(13, 23). The maximum counting speed is 5 kc/s if an OC83 transistor is employed for T1. The input pulses are used to operate this transistor which is connected in a blocking oscillator circuit. The output winding of the blocking oscillator transformer has a large number of turns in order that the voltage developed shall be great enough to operate the Dekatron. An OC76 transistor is used in the coupling circuit to invert the phase of the positive going output pulses from the zero cathode so that pulses which are suitable for the operation of the blocking oscillator of a succeeding stage are obtained. The capacitance coupling from the output cathode of the Dekatron to the base of the OC76 coupling transistor controls the duration of the pulses which are fed to the succeeding Dekatron. The reset pulses should be of 100 V amplitude and 50 μ sec duration.

The circuit of Fig. 4.32 shows how a GCA10G or a GSA10G tube may be used for forward counting when Digitron readout is not required⁽¹³⁾. The input and coupling circuits may be similar to those of Fig. 4.30 or 4.31.

4.4.11 Reversible Counting with Digital Readout⁽¹⁸⁾

The circuit of Fig. 4.33 illustrates the use of GCA10G or GSA10G tubes in reversible counting

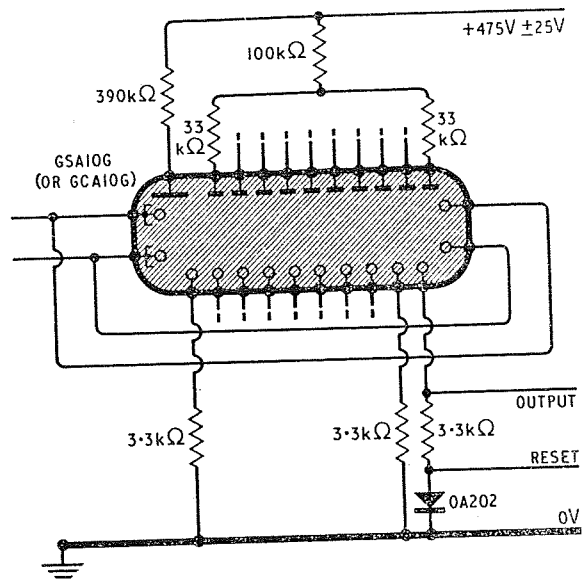

Fig. 4.32 A circuit for the GSA10G (or GCA10G) without Digitron readout

circuits which provide digital indication. The principle of operation of this circuit is the same as that of Fig. 4.27, but Digitron readout has been added. The input pulses should be of 100 V in amplitude and 60 μ sec in duration with an overlap of at least 15 μ sec. If the first pulse is applied to the 'A' input and the second pulse to the 'B' input, the count will increase, but if the first pulse is applied to the 'B' input and the second pulse to the 'A' input, subtraction will take place.

4.4.12 Circuits for Division

If a 10-way Dekatron is used in the circuits which have been discussed, it will divide the number of incoming pulses by 10 and similarly a 12-way Dekatron can be used to divide by 12. If the 0 and 5 main cathodes of a 10-way Dekatron are connected together and the junction is returned to earth via a load resistor, the circuit can be used to divide by five, since two output pulses will be obtained across the load for each complete revolution of the discharge in the tube.

If the even cathodes of a decade selector tube are connected to a load resistor and the odd cathodes are connected to earth directly, the system can be

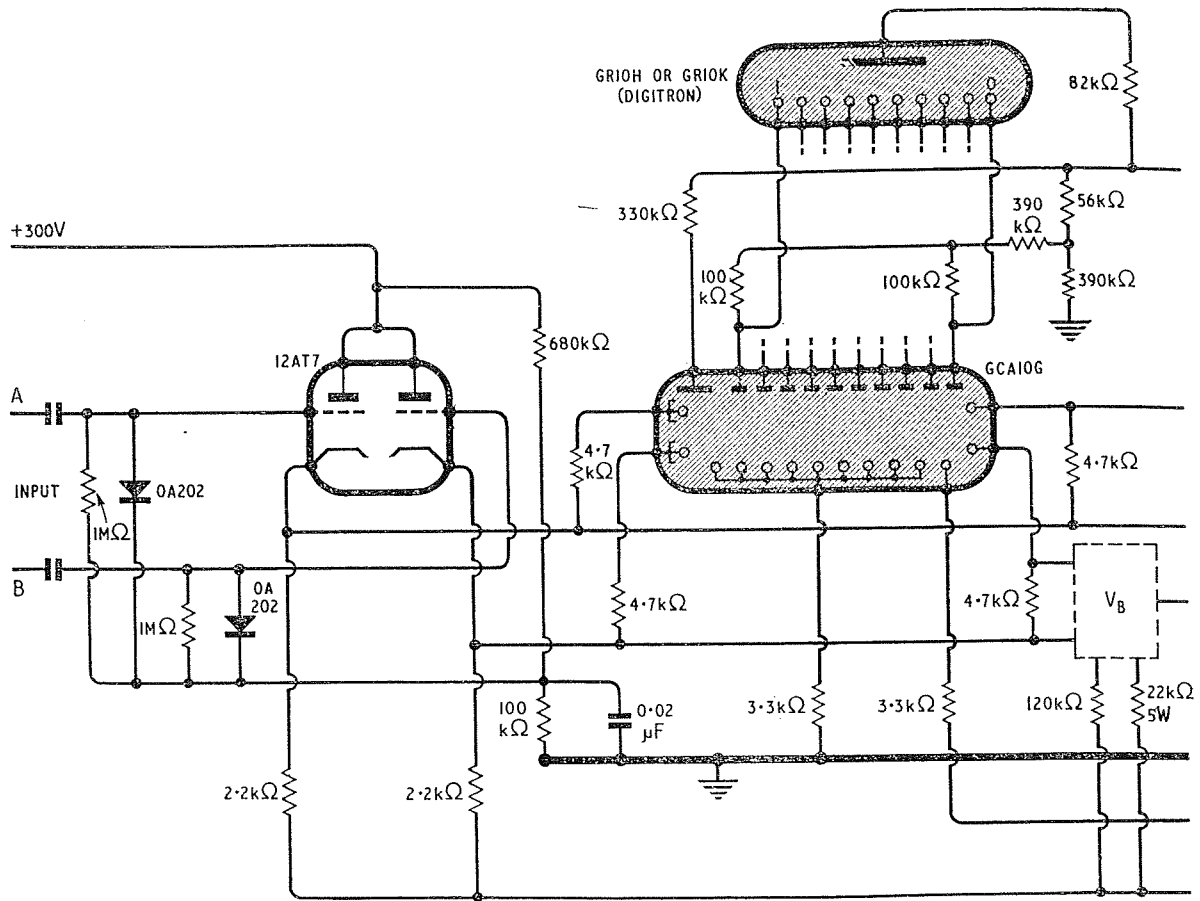

Fig. 4.33 A bidirectional

used to divide by two. The 12-way selector tube type GS12D is especially versatile in this type of application, since it can be used to divide by 2, 3, 4, 6 or 12. The output pulses are equally spaced.

4.4.13 The GC10D Single Pulse Dekatron^(13, 24)

The GC10D single pulse Dekatron requires only one input pulse to cause it to count. In addition it has the advantage that it can operate at frequencies up to 20 kc/s. The structure of the GC10D tube is similar to that of the double pulse Dekatron shown in Fig. 4.1, except that forty identical cathodes surround the common anode instead of the thirty cathodes used in double pulse tubes. Ten of the cathodes are main cathodes, whilst the remaining thirty are transfer or guide cathodes. There are three

guide cathodes between each two main cathodes.

All of the guide cathodes which are on the clockwise side of the adjacent main cathode are joined together and are known as the first guides (G_1 in Fig. 4.34). The electrodes on the clockwise side of each of the first guides are also joined together and are known as the second guides (G_2). Nine of the third guides are joined together (G_3), but the third guide preceding the output cathode is brought out to a separate base pin and is shown on the right hand side of the GC10D circuit symbol in Fig. 4.34. It is known as the output third guide.

The basic type of circuit in which the GC10D can be used for counting random pulses is shown in Fig. 4.34. The first and second guides are joined together via a resistor and a capacitor in parallel and are returned to a source of positive bias via a

MULTI-ELECTRODE GAS FILLED TUBES AND THEIR CIRCUITS

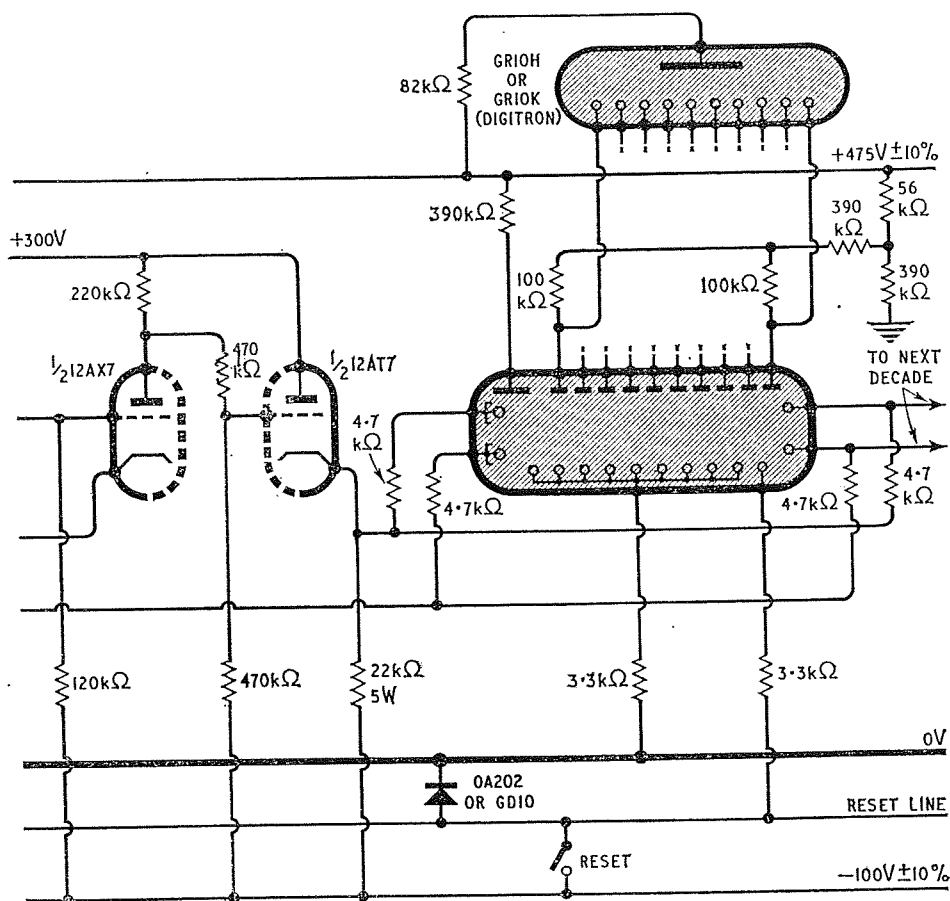

counter with Digitron readout

resistor R_1 and a diode D_1 . The third guides are returned to earth via a parallel resistor and capacitor. The small capacitors in the guide circuits limit the rate of change of guide potential to a suitable maximum value.

The negative input pulses are applied directly to the second guides and also via the parallel resistor and capacitor to the first guides. When the pulse is applied, the discharge moves one position in a clockwise direction from the glowing main cathode to the adjacent first guide which has been strongly primed. The anode voltage falls so that the first guide to anode potential is equal to the maintaining voltage of the tube and the discharge to the main cathode is then extinguished.

The capacitor in the first guide circuit charges from the current passing to the guide and the first

guide potential increases. The discharge, therefore, transfers to the second guide which is still at its maximum negative potential. Transfer will occur when the potential across the capacitor in the first guide circuit is equal to the difference between the primed striking voltage and the maintaining voltage of the tube.

During the remainder of the input pulse the discharge rests at the second guide, but when the pulse ceases the anode potential rises so that the anode to second guide voltage is kept at the maintaining voltage of the tube. The third guide which is strongly primed then strikes, but soon the capacitor in the third guide circuit becomes charged from the third guide current to a potential which is great enough to cause the discharge to transfer to the succeeding earthed main cathode.

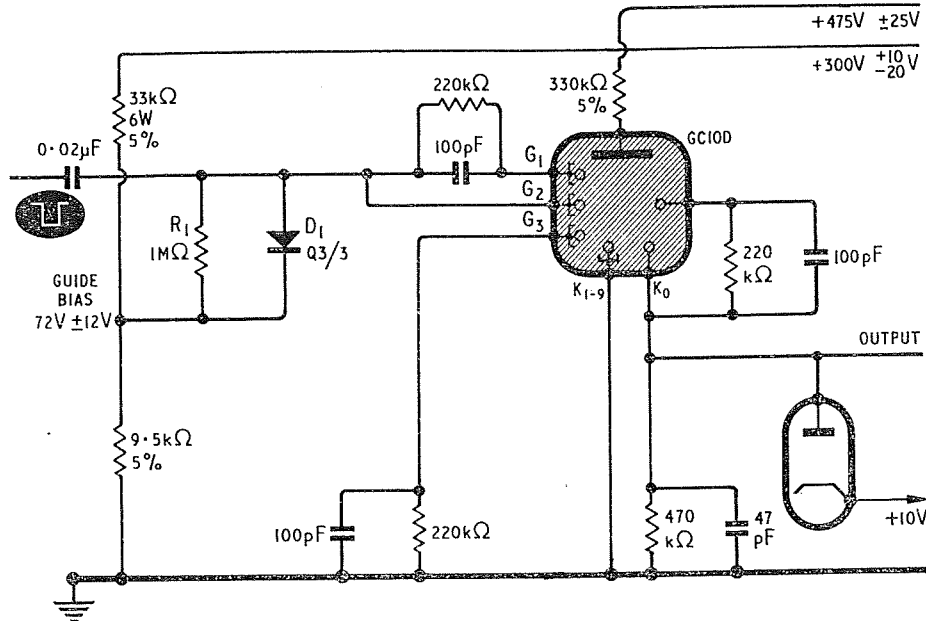

Fig. 4.34 The basic circuit for the single pulse GC10D tube

Although each count requires four separate steps (as compared with the three steps of the double pulse Dekatrons), the time the discharge remains at the first and third guides is extremely short owing to the automatic transfer mechanism as the capacitors in the guide circuits charge. The length of time for which the discharge rests at the second guide electrode is determined by the length of the input pulse. Thus the four stepping operations which take place in a single pulse Dekatron can be arranged to occur in a shorter time than the three steps of the double pulse tube.

The diode D_1 presents a large impedance to the input pulses and serves to prevent the first and second guide electrodes from becoming appreciably more positive than the guide bias supply point. If the diode were omitted, the ions from the adjacent conducting main cathode would produce a small current in R_1 which would result in an additional positive bias being formed at the guides.

The third guide preceding the output cathode is connected to the latter by a resistor and capacitor in parallel. When the output cathode is conducting and is at a positive potential (owing to the flow of current through the cathode resistor), the potential of the third guide is raised to the potential of the

output cathode. The discharge is thus prevented from returning from the output cathode to the preceding third guide when the output cathode potential becomes positive with respect to earth.

The output cathode should not be allowed to rise to a potential above +10 V or the discharge may transfer spontaneously from this cathode to another

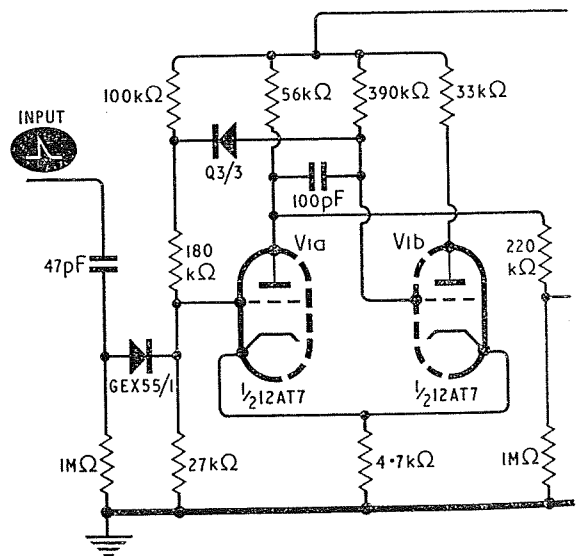

Fig. 4.35 An input circuit for the GC10D with

electrode. A clamping diode is, therefore, used from the output to a 10 V supply as shown in Fig. 4.34.

The amplitude of the input pulses to the second guides of the tube should be between 133 and 195 V and their duration should not be less than 25 μ sec.

A suitable input circuit for the GC10D is shown in Fig. 4.35. The pulse shaper, consisting of $V1a$, $V1b$ and $V2a$, is similar to the input circuit of Fig. 4.21, but the capacitor connecting the anode of $V1a$ to the grid of $V1b$ has been reduced to 100 pF so that pulses of about 25 μ sec duration are fed into the GC10D tube instead of the 80 μ sec pulses which are required for the operation of the 4 kc/s double pulse tubes.

A pulse coupling amplifier, $V2b$, is included in the circuit of Fig. 4.35. The grid and cathode of this valve also serve as the diode shown in Fig. 4.34. The output from the circuit may be fed into the capacitor marked C in Fig. 4.20 so that $V3$ of Fig. 4.20 serves as the next decade, $V1$ and $V2$ being omitted.

If a -20 V supply is available, the point marked 'A' of Fig. 4.35 may be taken to it instead of to earth, in which case the cathode of $V2b$ should be taken directly to earth. The potential divider in the cathode circuit of $V2b$ is then eliminated.

It is important that the stray capacitance from the anode of the GC10D to earth should be kept to

a minimum; the anode resistor should not be more than $\frac{1}{4}$ in from tag 4 of the tube base.

GC10D Sine Wave Circuit⁽¹³⁾

The GC10D may be used in the circuit of Fig. 4.36 to count the peaks of sine waves. The amplitude of the input waveform should be between 65 and 100 V R.M.S. The circuit may be used to feed a second decade by connecting the output to the capacitor C of Fig. 4.20, $V1$ and $V2$ of Fig. 4.20 being omitted.

4.4.14 Coupling Dekatrons to Magnetic Counters

Dekatrons may be used to divide the frequency of an input signal so that the output pulse frequency is not too great to be counted by an electro-magnetic counter. The output pulses from the Dekatron cannot be fed directly into the magnetic counter, since the output power which a Dekatron can supply is much too small to operate a magnetic counter directly and the pulse duration will not, in general, be suitable.

A typical circuit for coupling a 4 kc/s Dekatron to a magnetic counter is shown in Fig. 4.37⁽²⁵⁾. The double triode $V2$ forms a monostable multi-vibrator circuit which is used to amplify and shape

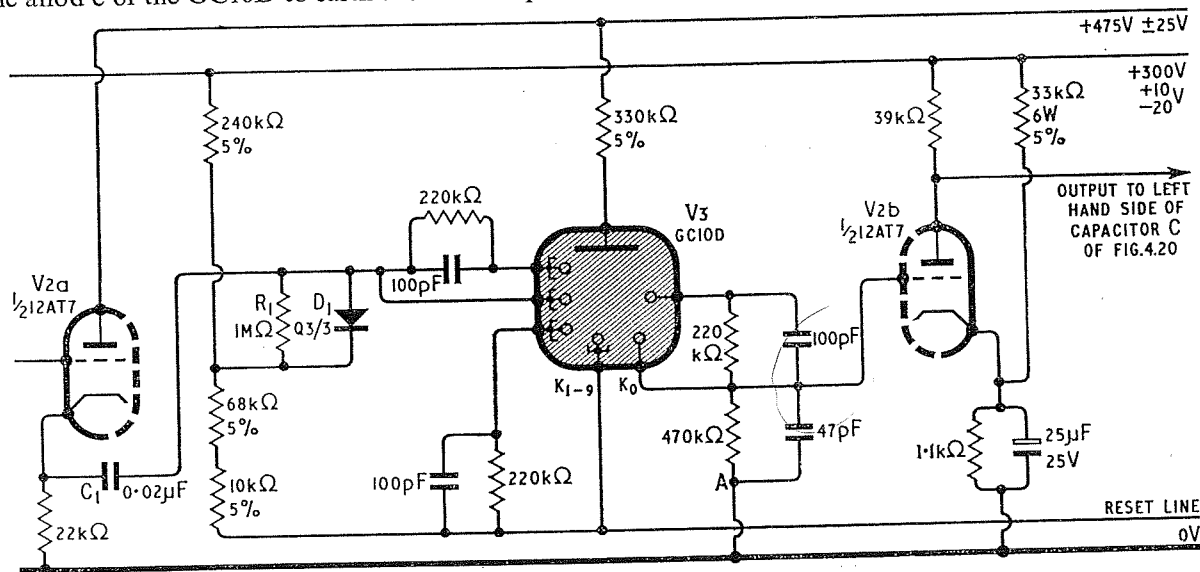

a coupling circuit for driving a 4 kc/s tube

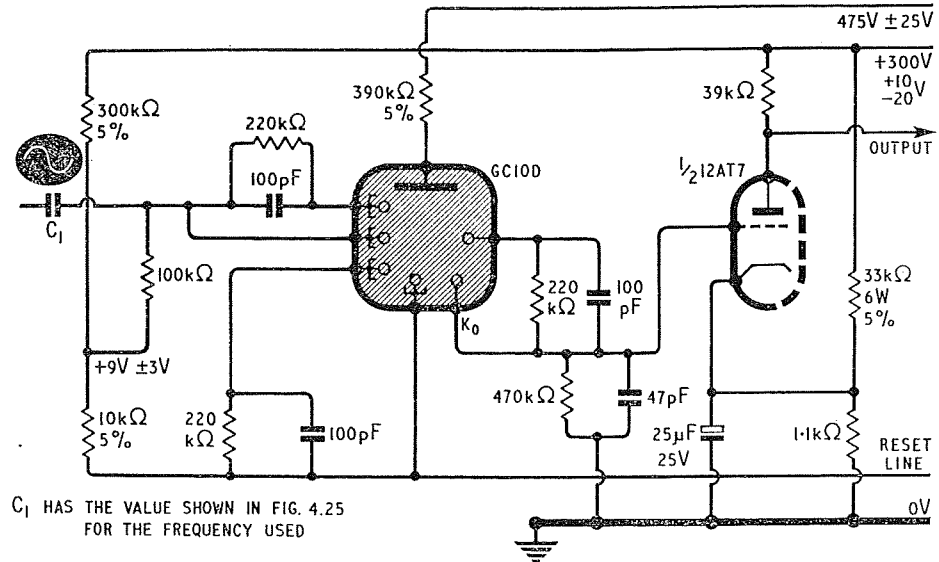

Fig. 4.36 A sine wave input circuit for the GC10D

the pulses from the Dekatron, $V1$. $V2a$ is normally conducting because its grid is connected to the +350 V line via the counter coil, whilst $V2b$ is normally cut off by the bias produced by the flow of the $V2a$ current through the common cathode resistor. In the quiescent state no appreciable current, therefore, flows through the magnetic counter in the $V2b$ anode circuit.

If a negative going pulse is applied to the grid of $V2a$, this triode is cut off and $V2b$ conducts, thus operating the magnetic counter. After a preset time the circuit returns to its initial state and is then ready to receive another pulse. Although the output pulses from the Dekatron are positive going, the positive leading edges are shorted to earth by the OA85 diode. The negative trailing edges are

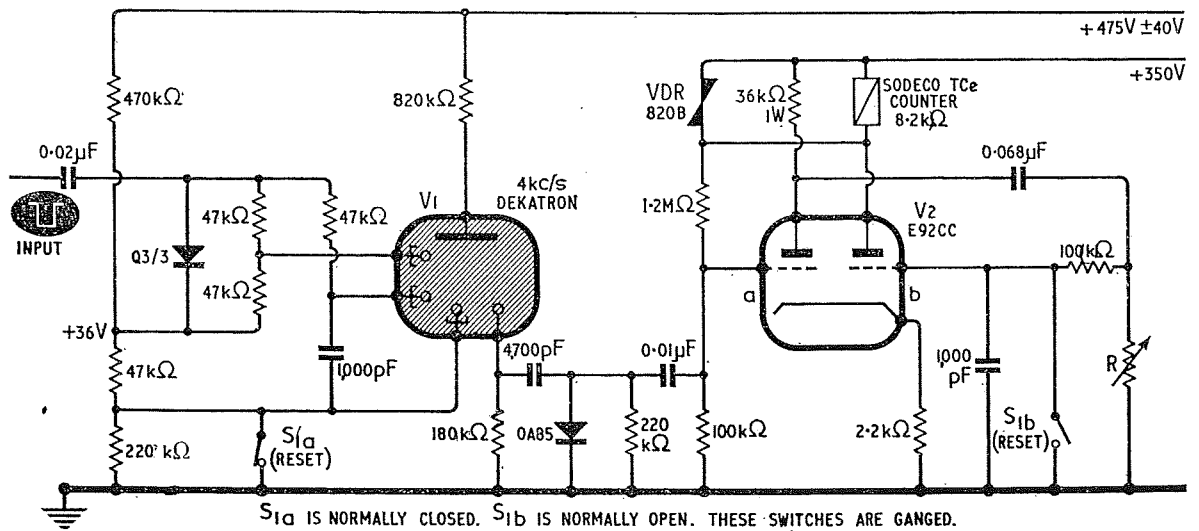

Fig. 4.37 The use of a 4 kc/s Dekatron for feeding a magnetic counter

Table 4.4 BASIC DATA FOR ERICSSON DEKATRON TUBES

Current Types	Max. Counting Rate (kc/s)	Nominal Maintaining Voltage (volts)	Min. V_b (volts)	Max. i_a (μA)	Min. i_a (μA)	Recommended Operating Conditions						Dimensions			
						i_e (μA)	V_b (volts)	Anode Load (ohms)	Max. cathode Load (ohms)	Guide Bias (volts)	Pulse Drive (volts)	Pulse Duration (μsec)	Reset Pulse (volts)	Max. Diameter (mm)	Max. Sealed Height (mm)
GC10B, GC10B/S, GC10/4B, GC12/4B	4	191	350	550	250	310 $\pm 20\%$	475	820k	150k	+18	-145 ± 15	80	-120	29.5	88.5
GC10B/L	4	190	350	550	250	310 $\pm 20\%$	400	470k	100k	+35	-145 ± 15	80	-120	29.5	87.5
GS10C/S	4	192	400	550	250	325 $\pm 20\%$	475	680k	150k	+36	-145 ± 15	80	-120	33.1	70.5
GS10D	10 or 20	208	440	900	700	800	475	300k	47k	+50	-145 ± 15	33 $\pm 20\%$	-140	33.1	70.5
GS10E	10		440	900	700	800	475	240k		± 5	-130	25	-120	33.1	70.5
GS10J	1		150			350	200	330k	3.3k	+12	-24	300	-120	30	36
GS10H	5	187	380	370	250	340	475	820k	82k	+35	-145 ± 15	75	-120	29.5	54.2
GCA10G, GSA10G	10	240	440	900	500	620	475 ± 25	390k	3.3k	+60 ± 5	-150 ± 10	30	-100	33.1	70.5
GS12D	4	191	400	350	190	270 $\pm 20\%$	475	910k	270k	+36	-145 ± 15	80	-120	29.5	88.5
GC10D	20	215	420	1200	700	800	475	330k		+72 ± 12	-144 ± 50	25	-140	29.5	88.5
Maintenance Types															
GS10G	10	210	400	900	700	725	475	300k	68k		-100	30	-140	29.5	54.2
GS10K	10	210	480	2000	1500	500	500	120k	27k	+85	-150	65	-120	29.5	54.2
GC10/2P	1	190	320	500	315	350 $\pm 10\%$	475	820k	150k	+18	-145 ± 15	350	-120	19	47.5
GS12C	4	192	350	550	250	325 $\pm 20\%$	475	680k	150k	+36	-145	80	-120	29.5	96

Ericsson tubes should now be obtained from Hivac Ltd.

Table 4.5 ERICSSON TUBE ESCUTCHEONS,

Current Types:	Escutcheon (Ericsson)	Base	BASE								
			1	2	3	4	5	6	7	8	9
GC10B, GC10B/S GC10B/L	N78211 (bakelite) or N79368 (brass)	I.O.	K_{1-9}	-	G_1	a	G_2	-	K_0	-	
GC10/4B, GC10/4B/L	(As GC10B)	I.O.	K_{1-9}	K_D	G_1	a	G_2	K_A	K_B	K_C	
GC12/4B	N79369 (brass)	I.O.	K_{1-11}	K_C	G_1	a	G_2	K_A	K_B	K_D	
GS10C/S, GS10D GS10E	N80977 (brass)	Duodecal + base cap	K_0	K_9	K_8	K_7	K_6	K_5	K_4	K_3	K_2
GS10H, GS10J	(As GC10B)	B17A	K_6	K_5	I.C.	K_4	K_3	I.C.	K_2	a	K_1
GS12D	N84538 (brass)	Duodecal + base cap + 2 flying leads	K_0	K_{11}	K_{10}	K_9	K_8	K_7	K_6	K_5	K_4
GCA10G	(As GC10B)	B27A	K_{1-9}	K_0	RG_2	RG_1	A_1	A_0	A_9	A_8	A_7
GSA10G	(As GC10B)	B27A	K_1	K_0	RG_1	RG_2	K_9	A_8	K_8	K_7	I.C.
GC10D	(As GC10B)	I.O.	K_{1-9}	G_3	G_1	a	-	K_0	G_3 out	G_2	
Maintenance Types: GS10G	(As GC10B)	B26A or B27A	K_6	K_5	K_4	G_2	K_3	I.C.	K_2	I. C.	K_1
GS10K	-	B27A	K_5	I.C.	K_4	G_1	K_3	I.C.	K_2	G_2	K_1
GP10/2P	N84338 (brass)	B7G	I.C.	G_1	K_{1-8}	G_2	K_0	K_9	a		
GS12C	N79369 (brass)	16 tags for soldering	a (Red)	-	K_0	K_{11}	K_{10}	K_9	K_8	K_7	G_2

BASES AND CONNECTIONS

CONNECTIONS																	
10	11	12	13	14	15	16	17	19	20	21	22	23	24	25	26	27	28
K_1	G_2	G_1	Base Cap = Anode.														
K_0	RG_2	RG_1	K_9	K_8	G_2	K_7	G_1										
K_3	K_2	K_1	Base Cap = anode			Yellow lead = G_1			Green lead = G_2								
A_6	A_5	A_4	A_3	A_2	I.C.	G_2	G_1	-	-	-	-	-	-	-	-	-	a
K_6	K_5	I.C.	K_4	K_3	G_2	G_1	K_2	A_1	A_0	A_9	A_7	A_6	A_5	A_4	A_3	A_2	a
K_0	RG_2	RG_1	K_9	I.C.	K_8	K_7	G_1	-	-	a	-	-	a	-	-	a	-
K_0	G_3	K_9	I.C.	K_8	I.C.	K_7	K_6	-	-	-	-	-	-	-	-	-	a
K_6	K_5	K_4	G_1	K_3	K_2	K_1											

G_1 = 1st Guides G_3 out = Output 3rd guide (GC10D) RG_2 = 2nd Routing guide
 G_2 = 2nd Guides a = Main anode
 G_3 = 3rd Guides RG_1 = 1st Routing guide A_5 = Auxiliary anode 5
 K_4 = Main cathode A

ELECTRONIC COUNTING CIRCUITS

thus passed to the E92CC multivibrator which is triggered. The input circuit to the Dekatron may be of the type shown in Fig. 4.21 or, for sine wave inputs, as in Fig. 4.22.

Ideally, the value of the resistance R should be such that the current pulse to the magnetic counter is of about the same duration as the time between pulses when the circuit is operating at its maximum speed. For example, if the Dekatron is counting at 250 pulses per second, the magnetic counter will be operating at 25 pulses per second and the value of

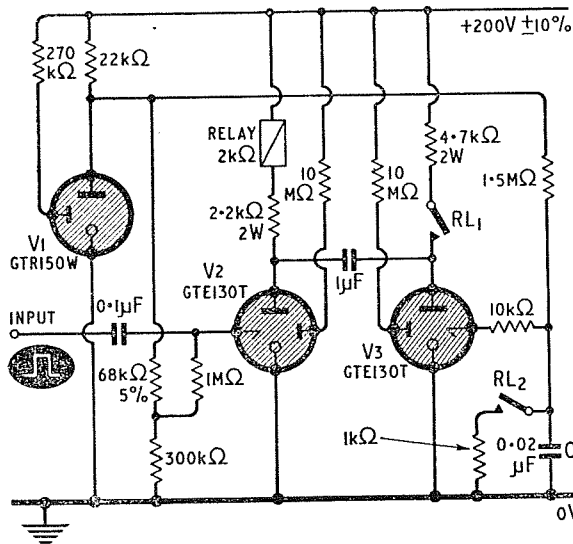

Fig. 4.38 A trigger tube circuit for operating a magnetic counter from a Dekatron

R should be about $120\text{ k}\Omega$. The voltage dependent resistor, VDR 820B, is used to short circuit the voltage peaks formed when the current ceases to flow in the relay.

During the operation of the reset switch, S_{1a} , a spurious pulse might be registered by the magnetic counter, but this can be prevented by earthing the grid of $V2b$ by means of S_{1b} during the resetting of the Dekatron. The switches however may be replaced by relays if, it is so desired. S_{1b} must open after S_{1a} has closed at the end of the resetting operation.

A trigger tube circuit for operating a relay or electromagnetic counter is shown in Fig. 4.38⁽¹³⁾. It is very suitable for driving a relay from the out-

put of a decade tube. The maximum operating speed is about 15 pulses per second.

When an input pulse is received, the combined effect of the pulse and the trigger bias cause $V2$ to strike and the relay in the anode circuit of this tube closes. The relay contacts RL_1 close and RL_2 open. The capacitor C charges through the $1.5\text{ M}\Omega$ resistor and after a short time $V3$ ignites. The negative pulse at the anode of this tube is coupled to the anode of $V2$ which is thus extinguished. The relay contacts RL_1 open so that $V3$ is extinguished and in addition the contacts RL_2 close so that the capacitor C loses virtually all of its charge through the $1\text{ k}\Omega$ resistor. If RL_2 shorted C directly to earth, excessive sparking would occur at the contacts.

The circuit requires input pulses of about 25 V in amplitude and $100\text{ }\mu\text{sec}$ in duration. The relay or electro-magnetic counter should be rated at about 50 V, 25 mA. The GTR150W provides a stabilised supply of about 150 V for biasing the trigger electrodes of the tubes. The value of the capacitor C determines the duration of the energising pulses fed to the relay; with the values shown the duration of these pulses is about 50 msec.

4.4.15 Power Supplies for Ericsson Dekatrons⁽¹³⁾

Wherever possible the circuits designed by the Ericsson Company for their Dekatrons operate with power supply potentials of $475 \pm 25\text{ V}$, 300

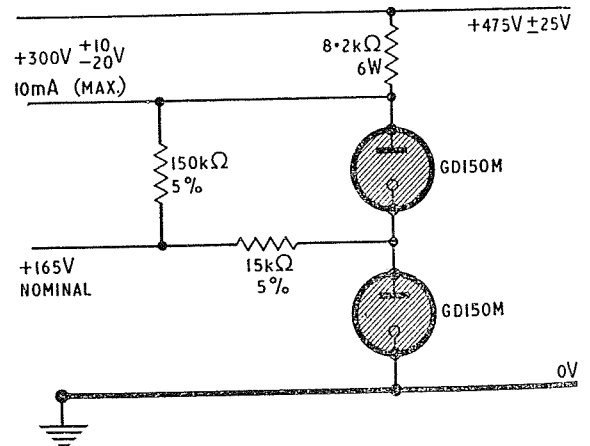

Fig. 4.39 A stabilised 300 volt power supply for Dekatron circuits

± 10 V, -20 V and -100 V. The $+300$ V supply may be obtained from the stabilised circuit of Fig. 4.39 which employs two Ericsson GD150M tubes and can supply up to 10 mA. The -20 V supply for the Dekatron output cathodes can be obtained from a potential divider across the -100 V power supply; care should be taken to ensure that the impedance of the -20 V line is not greater than 4 k Ω .

4.5 RAYTHEON AND SYLVANIA DOUBLE PULSE DECADE TUBES AND THEIR CIRCUITS

4 and 5 kc/s tubes:

Selector tubes: Sylvania } 6476
 Raytheon } 6476A
 Raytheon } 7978

'Computer' tube with access to 4 cathodes:
 Sylvania } 6802
 Raytheon }

Miniature tube with access to 3 cathodes:
 Sylvania } 6879

100 kc/s tubes:

Selector tubes: Sylvania } 6910
 Raytheon }
 Raytheon } 8262

'Computer' tube with access to 4 cathodes:
 Sylvania } 6909
 Raytheon }

'Computer' tube with access to 3 cathodes:
 Sylvania } 7155

Raytheon and Sylvania tubes which have the same type number are equivalents, but sometimes the Raytheon Company put the letters CK in front of the type number; for example, the CK6476 is equivalent to the 6476. British equivalents to some of these tubes are given in the appendix.

4.5.1 4 and 5 kc/s tubes

The 4 and 5 kc/s American tubes may be used in the 4 kc/s circuits given in Sections 4.3 and 4.4. In addition, some rather interesting circuits have been published by the American manufacturers.

In the circuit of Fig. 4.40⁽²⁶⁾, the whole of the triode anode current is obtained from the guide electrodes of the counting tube. The triode, V_1 , conducts only during the time the grid is receiving a positive going pulse, the duration of which is limited by the differentiating circuit in the input.

The circuit of Fig. 4.41⁽²⁶⁾ may be used to divide the incoming pulse frequency by a factor of eight. The input circuit is somewhat similar to that of Fig. 4.40. V_2 is normally cut off by the applied

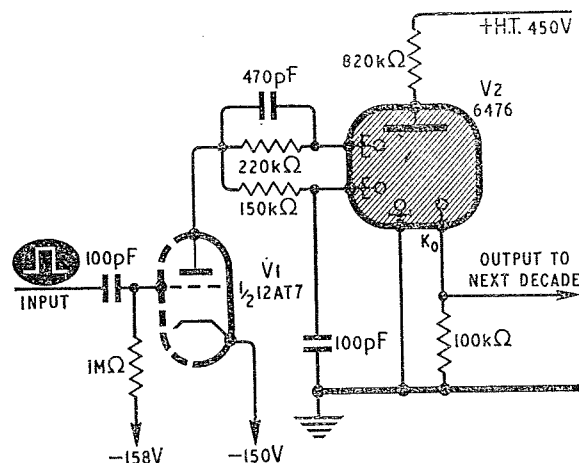

Fig. 4.40 A circuit for driving the 6476 tube

grid bias, but conducts when the discharge in V_3 first reaches K_8 ; the discharge is thus returned to the zero position, the ninth position being omitted. The resetting action is quite fast and no counts are missed provided that the pulses are spaced by at least 250 μ sec.

The circuit can be preset to divide by any desired number up to ten if an output from the appropriate cathode is used to operate the resetting valve, V_2 . All of the subsequent cathodes will be missed. Division by 2 or 5 may be accomplished by the method suggested in the previous section of this chapter, the resetting circuit being unnecessary.

4.5.2 100 kc/s Tubes

100 kc/s double pulse tubes function in exactly the same way as 4 kc/s double pulse tubes, but they can operate from rectangular guide pulses of 4 μ sec in duration which have a minimum overlap of 2 μ sec. The guide pulse amplitude should be between 120 and 140 V, which is very similar to that required for the 4 kc/s tubes. In actual practice, rectangular guide pulses are somewhat difficult to obtain and the tubes are normally operated from somewhat rounded pulses.

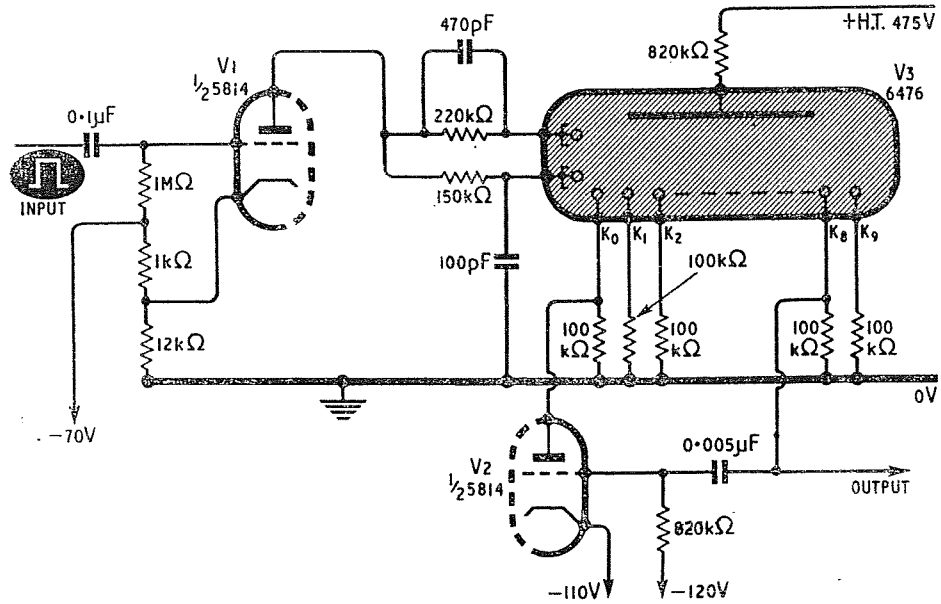

Fig. 4.41 A scale of eight frequency divider

Whenever double pulse tubes are used at high speeds, the anode resistor of the counting tube should be soldered directly to the tube base in order to keep stray anode to earth capacitance to a minimum. When 100 kc/s tubes are used at frequencies above 50 kc/s, a potentiometer should be included in the anode circuit so that the average anode current taken by the tube can be adjusted by at least 100 μ A above and below the specified value in order to obtain the optimum anode current for the tube concerned. The potentiometer cannot be soldered

directly to the anode tag of the tube, since this would increase the anode to earth capacitance. A fixed resistor should be included between the anode and the potentiometer.

A circuit which will drive a 6910 tube at frequencies up to 50 kc/s is shown in Fig. 4.42⁽²⁶⁾. A positive going pulse applied at the input through the differentiating circuit causes anode and screen grid currents to flow in the 5654 tube, V1, for a short time. Initially the capacitor in the screen grid circuit maintains the screen grid voltage well

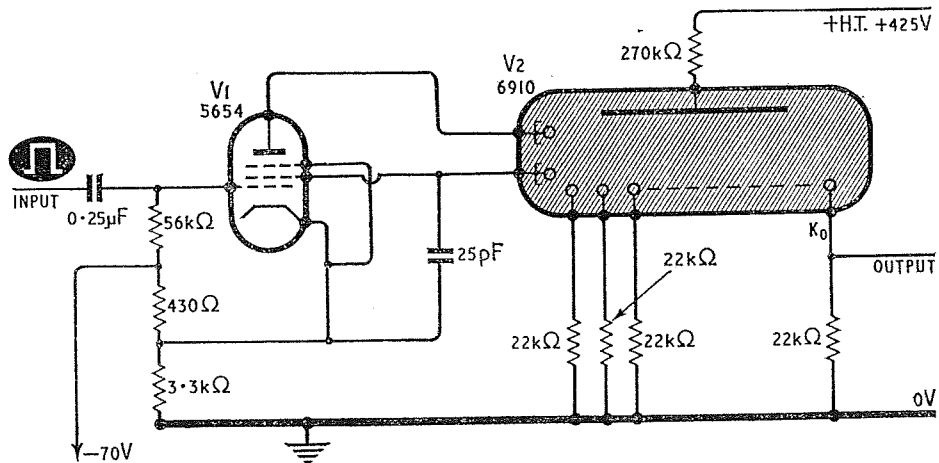

Fig. 4.42 A 50 kc/s counting stage

Table 4.6 BASIC DATA AND CONNECTIONS FOR THE AMERICAN DOUBLE PULSE TUBES

	6476	6802	6879	7978	6910	6909	7155	8262
Max. frequency (kc/s)	4	4	5	5	100	100	100	100
Anode current (μ A) max.	600	600	600	600	800	800	800	800
min.	300	300	300	300	600	600	600	600
Min. anode supply voltage	350	350	350	350	400	400	400	400
Min. transfer voltage	35	35	35	35	35	35	35	35
Min. guide bias (V)	+35	+35	+35	+35	+45	+45	+45	+45
Min. rectangular pulse amplitude (V)	-75	-75	-75	-75	-85	-85	-85	-85
Min. rectangular pulse duration (μ sec)	60	60	60	60	4	4	4	4
Min. reset pulse amplitude (V)	-120	-120	-120	-120	-120	-120	-120	-120
Min. reset pulse duration (μ sec)	50	50	50	50	4	4	4	4
Max. cathode resistor (k Ω)	150	150	150	150	50	50	50	50
Base	Modified duodecal	I.O.	B7G	13 pin	Modified duodecal	I.O.	B7G	13 pin
Bulb Type	T11	T9	T5 ^{1/2}	T9	T11	T9	T5 ^{1/2}	T9
<i>Connections</i>								
Pin 1	K ₀	K ₁₋₇	K ₈	a	K ₀	K ₁₋₇	K ₈	a
Pin 2	K ₉	K ₅	G ₁	K ₅	K ₉	K ₅	G ₁	K ₅
Pin 3	K ₈	G ₁	K ₁₋₇	K ₄	K ₈	G ₁	K ₁₋₇	K ₄
Pin 4	K ₇	a	G ₂	G ₂	K ₇	a	G ₂	G ₂
Pin 5	K ₆	G ₂	K ₀	K ₃	K ₆	G ₂	K ₀	K ₃
Pin 6	K ₅	K ₉	K ₉	K ₂	K ₅	K ₉	K ₉	K ₂
Pin 7	K ₄	K ₀	a	K ₁	K ₄	K ₀	a	K ₁
Pin 8	K ₃	K ₈	—	K ₀	K ₃	K ₈	—	K ₀
Pin 9	K ₂	—	—	K ₉	K ₂	—	—	K ₉
Pin 10	K ₁	—	—	G ₁	K ₁	—	—	G ₁
Pin 11	G ₂	—	—	K ₈	G ₂	—	—	K ₈
Pin 12	G ₁	—	—	K ₇	G ₁	—	—	K ₇
Pin 13	—	—	—	K ₆	—	—	—	K ₆
Base Cap	a	—	—	—	a	—	—	—

The 6476A tube is similar to the 6476, but the voltage between two electrodes other than the anode has a maximum value of 200 volts instead of the maximum rating of 140 volts for the 6476.

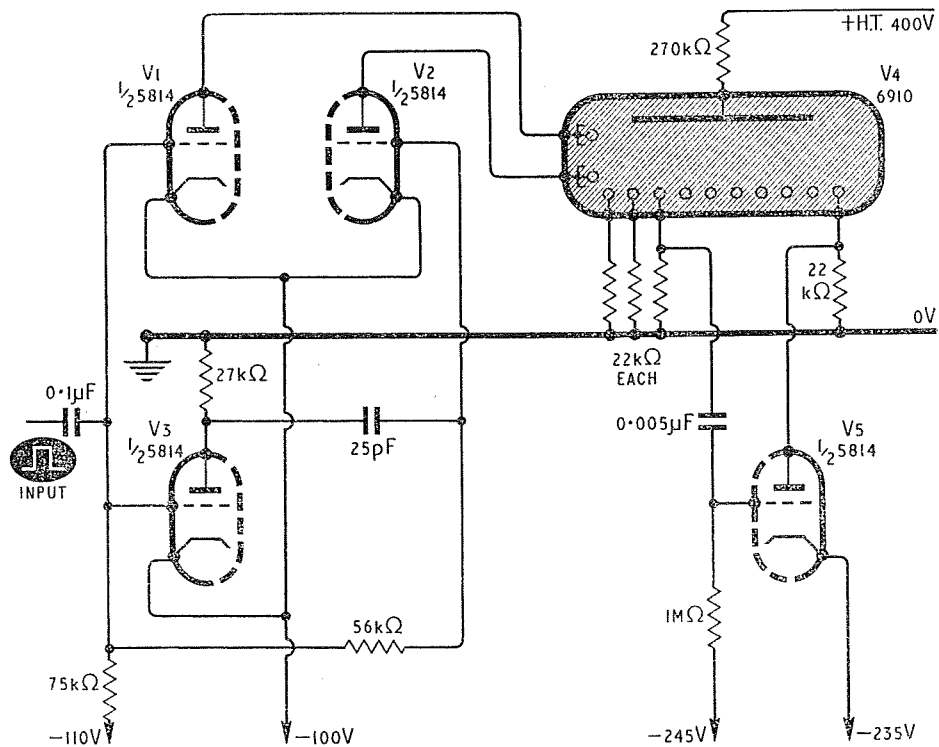

Fig. 4.43 A high speed frequency divider

above the cathode potential and the current taken by the anode results in the anode to cathode potential falling to a small value. The discharge transfers to the first guides at this point, but the low anode voltage causes the screen current to increase and the capacitor in the screen grid circuit is discharged. As the control grid potential of $V1$ falls, the anode voltage rises and the discharge moves to the second guide. When the screen capacitor recharges, the positive potential of the screen grid causes the glow to move to the succeeding main cathode.

The circuit of Fig. 4.43 may be used to divide the input pulse frequency by any number up to ten⁽²⁶⁾. The input frequency may have any value up to about 70 kc/s, but above this value the operation of the circuit is not very reliable unless the optimum component values and voltages are very carefully chosen. The circuit is similar to the slower circuit of Fig. 4.41, since a pulse taken from any cathode may be used to reset the discharge to the zero cathode.

The input pulses to this circuit should be positive going and have an amplitude of 10 V and a duration

of 4 μ sec. They are amplified by $V1$ and fed to the first guides. They are also amplified by $V3$ and differentiated by the anode circuit of this valve. The resultant waveform is mixed with a fraction of the original input signal and, after amplification by $V2$, the combined pulse is used to drive the second guides of the counting tube, $V4$.

4.6 THE CERBERUS DZ10 TUBE AND ITS CIRCUITS

The 3 kc/s Cerberus DZ10 decade selector tube differs from the tubes described in Sections 4.2–4.5, since it employs only one transfer or guide electrode between each two main cathodes. The guide electrodes and the main cathodes are so shaped that counting can occur in the forward or clockwise direction only. All of the main cathodes are connected to separate base pins. The tube is essentially a low voltage type, but it requires more current than the types which have been discussed previously. Further details of the DZ10 are given in the table.

Plate 1. Sodeco TCe5E counter.
(Courtesy: Sodeco)

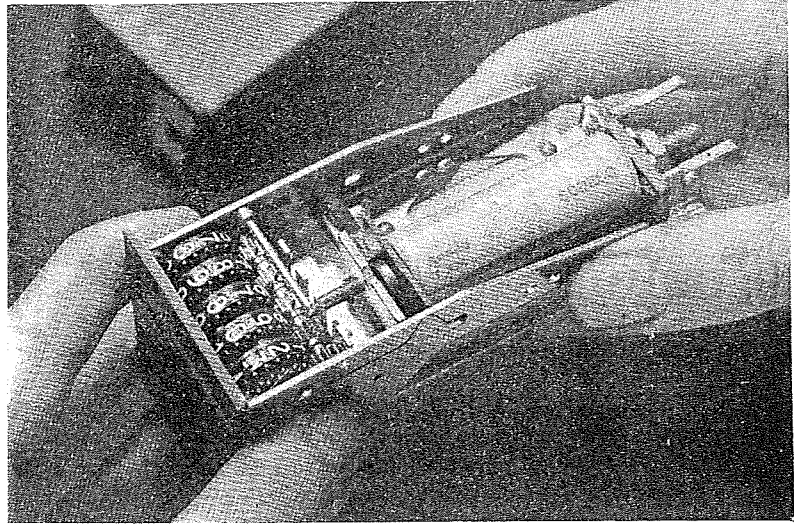

Plate 2. Sodeco TCeF4PE
predetermined counters.
(Courtesy: Sodeco)

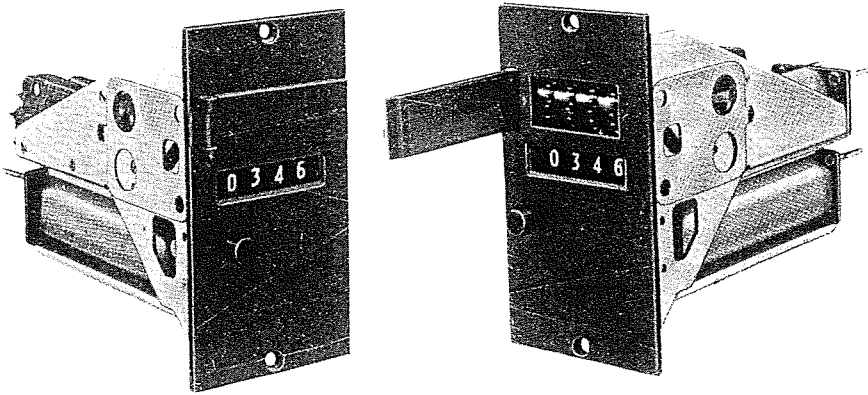
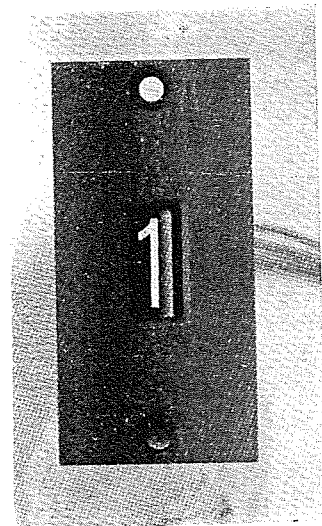
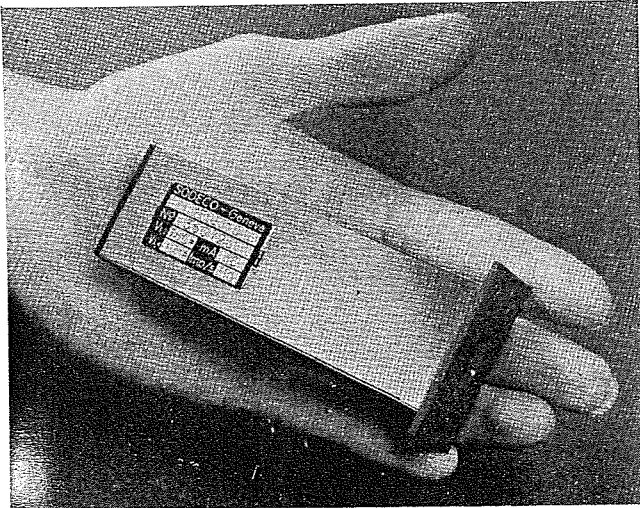

Plate 3. A Sodeco
single digit counter.
(Courtesy: Sodeco)



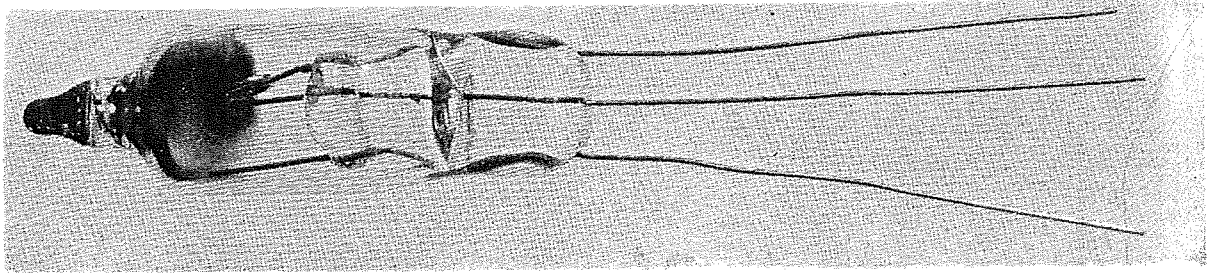

Plate 4. A miniature trigger tube
Type GTR120W. (Courtesy:
Ericsson)

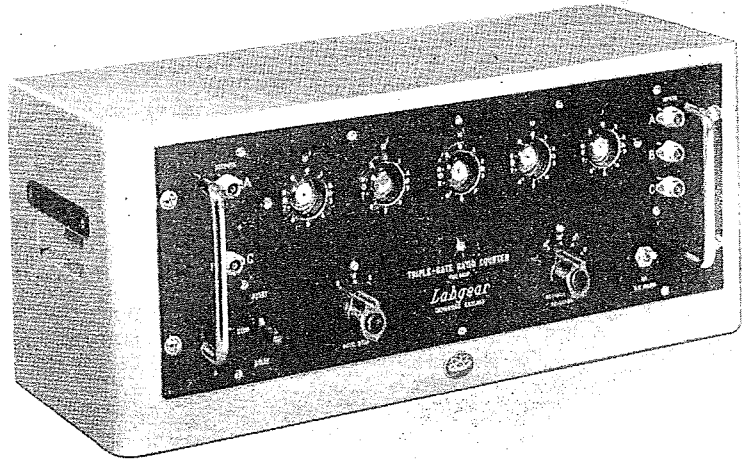

Plate 5. A typical scaler employing polycathode decade tubes.
(Courtesy: Labgear)

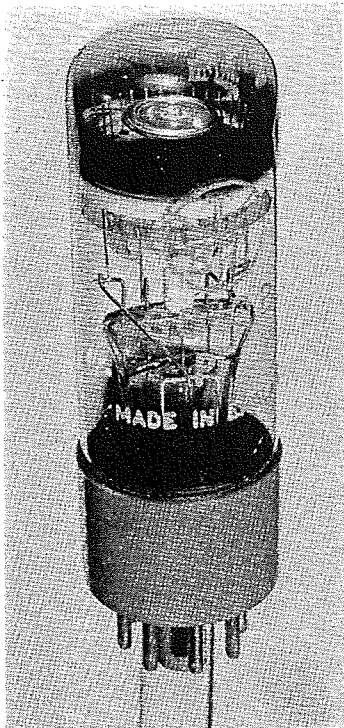

Plate 6. The GC10B decade tube. (Courtesy: Ericsson)

Plate 7. The GS10H miniature decade tube. (Courtesy: Ericsson)

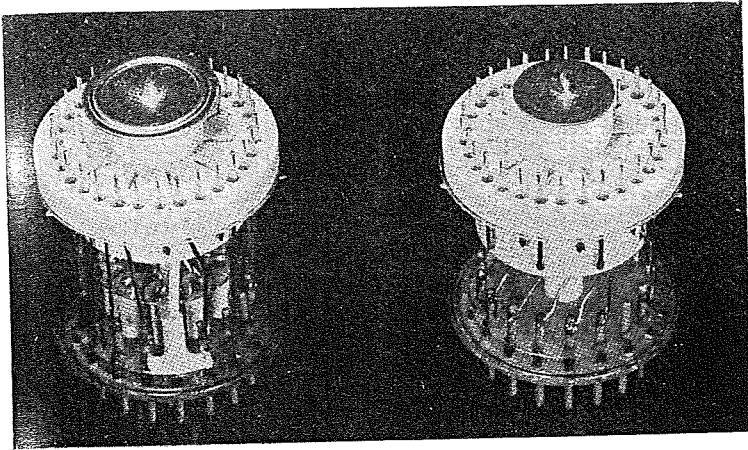
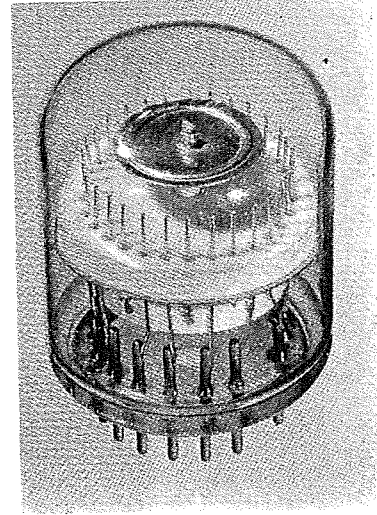

Plate 8. The electrode structure of the GSA10G (left) and the GCA10G (right) showing the auxiliary anodes. (Courtesy: Ericsson)

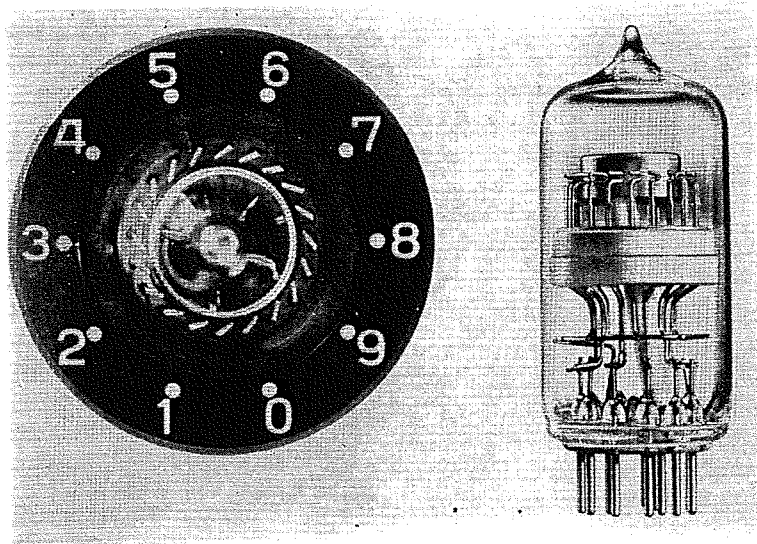

Plate 9. The EZ10B tube (Courtesy: Elesta)

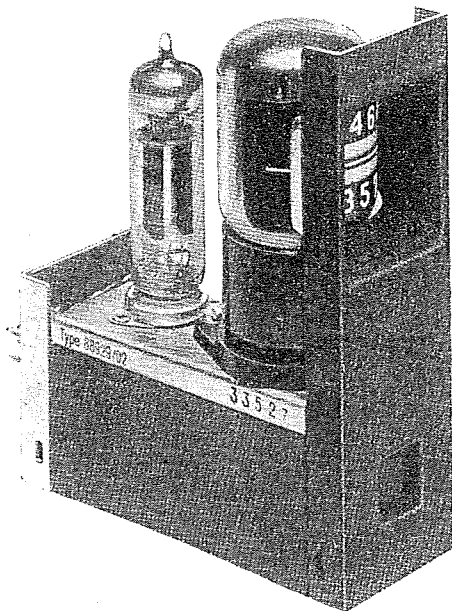

Plate 10. A 30 kc/s EIT decade module.
(Courtesy: Mullard)



Plate 11. An Ericsson VS10G trochotron.
(Courtesy: Ericsson)

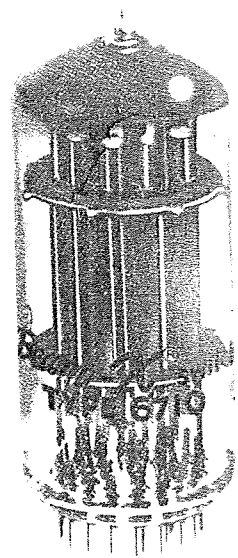

Plate 12. A Beam X tube
(Courtesy: Burroughs)

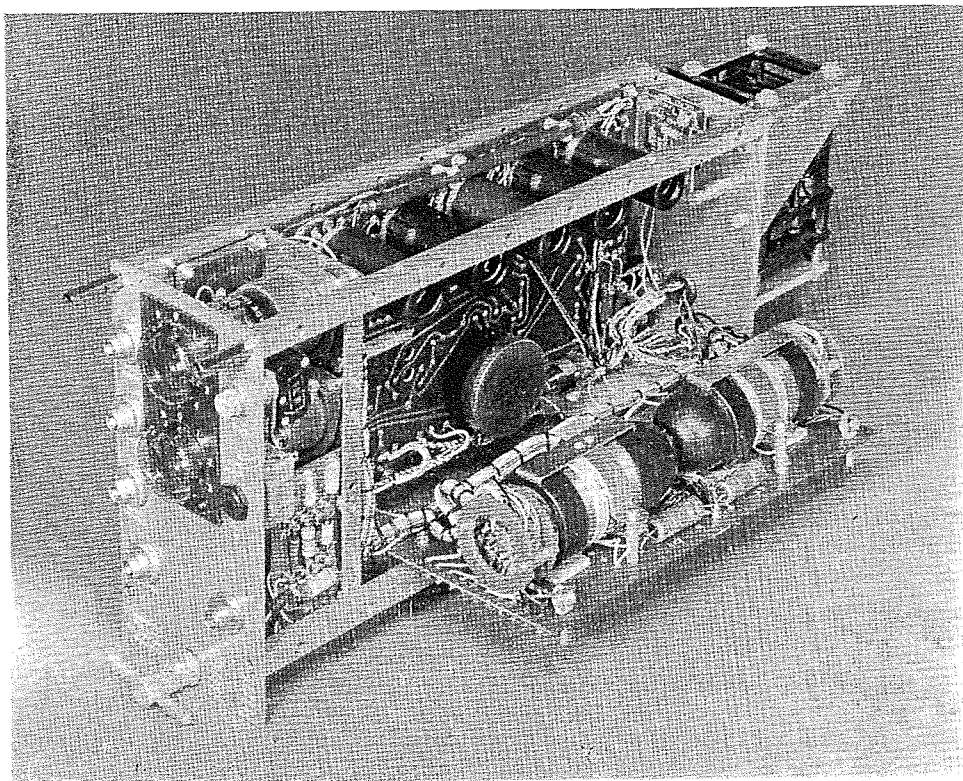

Plate 13. A two decade trochotron pre-scaler with GR10A readout-Bendix-Ericsson 2028A unit.
(Courtesy: Bendix-Ericsson)

MULTI-ELECTRODE GAS FILLED TUBES AND THEIR CIRCUITS

The five transfer cathodes which follow the main cathodes numbered zero to four inclusive are connected together and are brought out to the pin designated B_1 in the table of connections. The other five transfer cathodes are brought out to the connection marked B_2 . The two sets of transfer electrodes, B_1 and B_2 , are connected together in almost all circuits. The transfer electrodes receive a positive bias of about 30 V. The discharge, therefore, rests

fed to the grid of an EL83 pentode which amplifies the pulse and inverts its phase so that it is suitable for feeding into the succeeding stage.

Stages which will not be required to operate at frequencies above 1 kc/s do not require resistors and capacitors in their cathode circuits, although a resistor is, of course, required for those cathodes from which output pulses are to be taken. No cathode capacitors need, therefore, be used in any

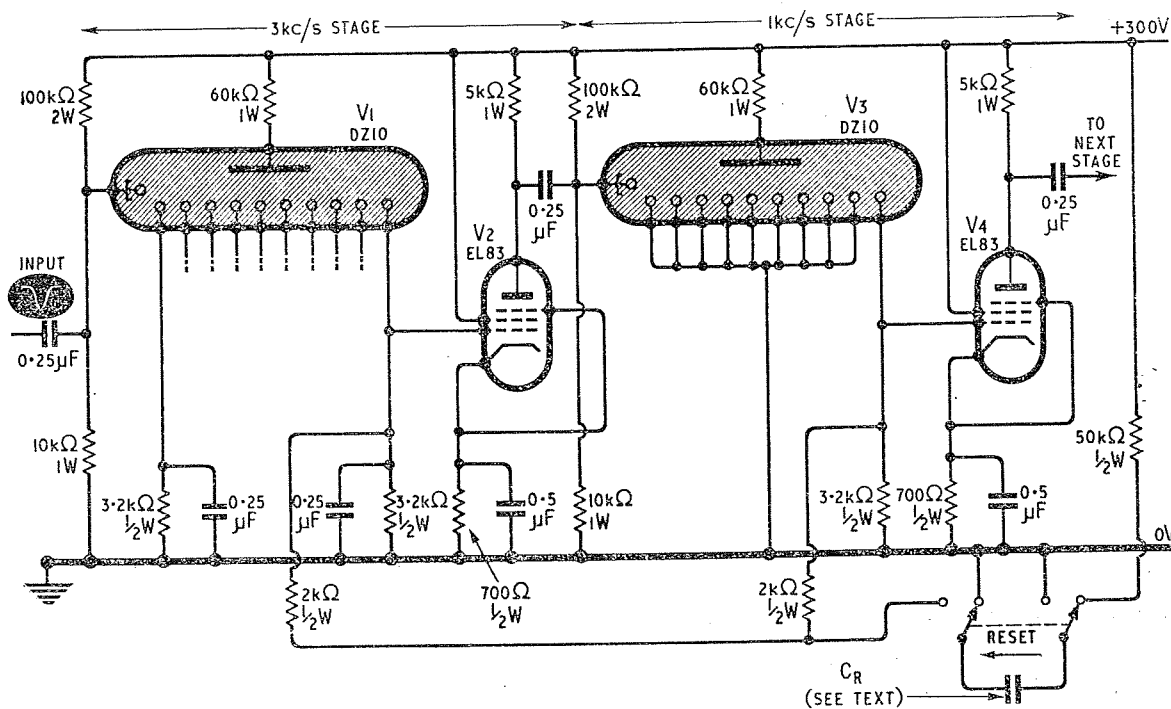

Fig. 4.44 A 3 kc/s counter using the Cerberus DZ10 tube

preferentially at the main cathodes except when the transfer cathodes are receiving a negative pulse. Each negative pulse applied to the transfer cathodes causes the discharge to move from a main cathode to the succeeding transfer cathode. At the end of the pulse the discharge moves to the next main cathode owing to the bias at the transfer cathodes.

A typical simple counting circuit is shown in Fig. 4.44. The input stage employs a resistor and a capacitor in parallel from each main cathode to earth; these components are necessary if the maximum counting speed of 3 kc/s is to be attained. The positive going pulse from the first decade is

stage after the first, since the maximum speed at which they will be required to count is one tenth of the maximum speed of the first decade, that is 300 c/s.

The internal resistance of the source of pulses feeding the circuit of Fig. 4.44 should be less than 4 kΩ or alternatively the amplitude of the input pulses should be greater than the values shown in the table. If positive going pulses of at least 150 μsec in duration are available, an EL83 circuit similar to the coupling circuits in Fig. 4.44 may be used as the input circuit; otherwise a circuit should be used which will lengthen the pulses to this figure.

ELECTRONIC COUNTING CIRCUITS

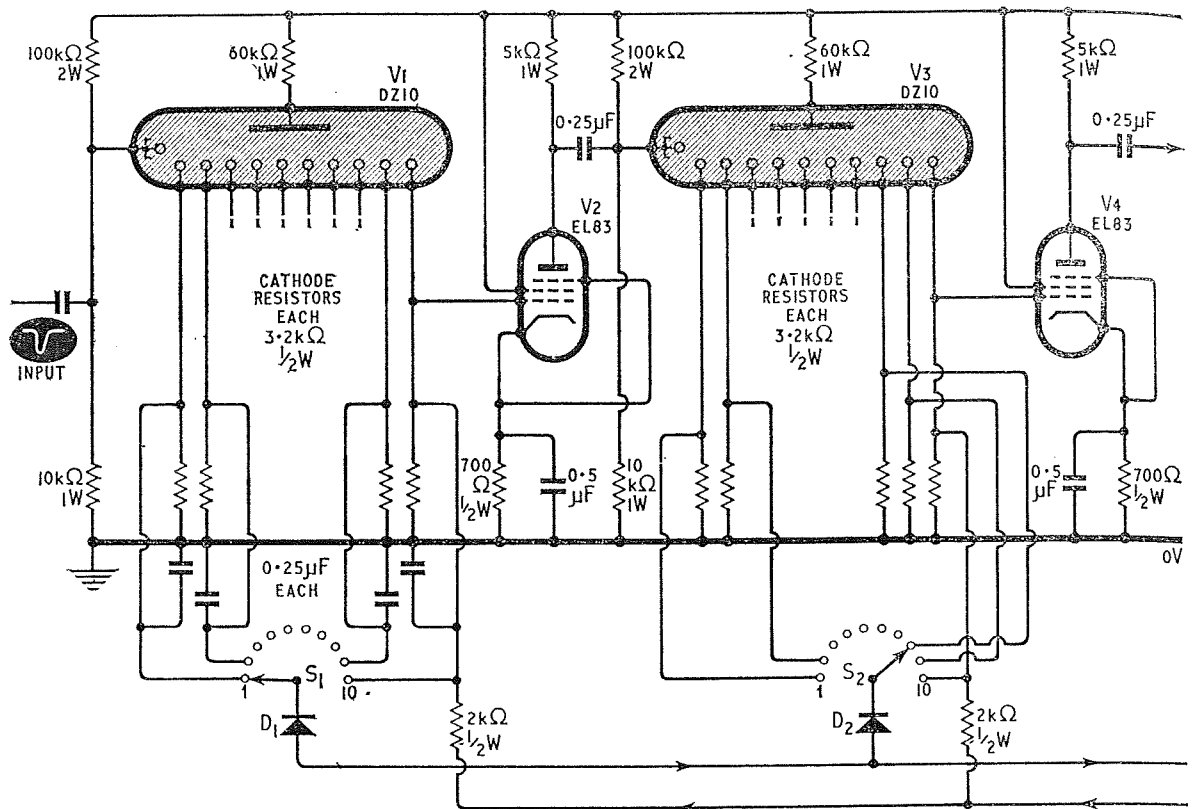

Fig. 4.45 A preset circuit using

Reset

During the counting operation the capacitor C_R becomes charged to the full H.T. voltage. When the reset switch is pressed, this capacitor provides a negative pulse which is fed to the zero cathode of each tube. All of the tubes are thus set to zero by the same process as for the double pulse tubes.

The value of C_R should be $2\ \mu\text{F}$ for resetting one decade and should be increased in proportion to the number of decades employed.

Preset Counter

DZ10 tubes may be used in the circuit of Fig. 4.45 for preset counting⁽²⁷⁾. The basic circuit is similar to that of Fig. 4.44, but cathode resistors are required in each of the cathode circuits of each decade.

The diodes D_1 and D_2 act as a simple coincidence circuit or AND gate. If the discharges rest at the first cathode of V_1 and at the first cathode of V_3 , these

cathodes will become positive with respect to earth. If S_1 and S_2 are in the positions shown, D_1 will be reverse biased by the cathode potential of V_1 , whilst D_2 will tend to be forward biased by the same potential, since D_2 is connected by S_2 to the eighth cathode of V_3 and this is at earth potential. D_1 therefore, acts as a high impedance and D_2 as a low impedance. These two diodes form a potential divider together with the eighth cathode resistor of V_3 . The junction of the two diodes remains at about earth potential owing to the ratio of their impedances.

If, however, the discharge in V_1 rests at the first cathode and the discharge in V_2 rests at the eighth cathode (and S_1 and S_2 are in the positions shown), both of these cathodes will be at a positive potential with respect to earth. The junction of the two diodes will reach this potential in spite of the fact that the cathode potentials tend to reverse bias both of the diodes, since negligible current is taken from the

MULTI-ELECTRODE GAS FILLED TUBES AND THEIR CIRCUITS

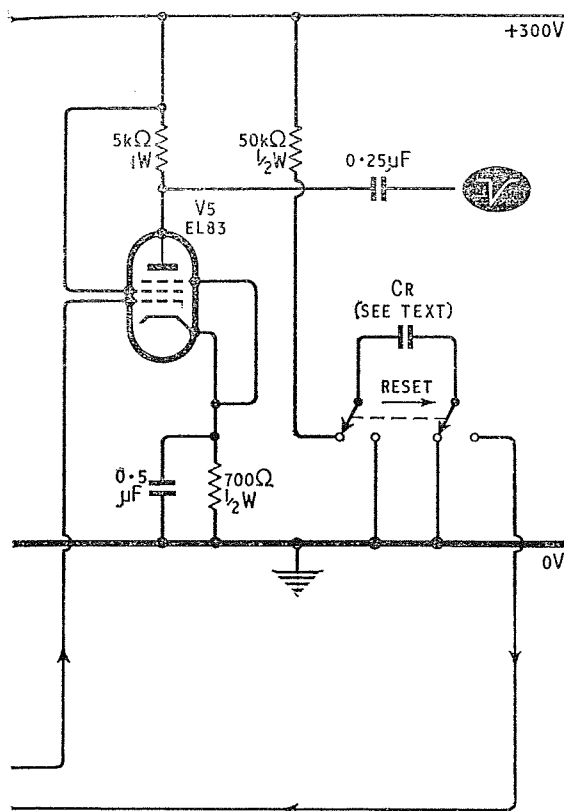

junction of the diodes by the grid of *V5*. When the discharge rests at the main cathodes of each of the counter tubes which have been selected by *S*₁ and *S*₂, the junction of the diodes becomes positive and this pulse is fed to *V5* where it is amplified and phase inverted.

If *S*₁ and *S*₂ are in the position shown, the potential at the anode of *V5* becomes lower when (and only when) the number of counts indicated is 81. At any other state of the count, no appreciable positive potential is present at the junction of the two diodes. Further decades similar to the second decade may be added to the circuit with all of the diodes returned to the grid of *V5*. An output pulse will then be obtained from *V5* only when the discharge in each of the decades rests at the cathodes selected by the switches.

The output pulses from the anode of *V5* can be used for operating any mechanism when the count has reached the value preset by the switches and can also be used to reset the counting circuit to zero automatically. The reset circuit can, of course, be arranged so that the counter is reset to any desired number of counts instead of to zero.

the DZ10 tube

Table 4.7 BASIC DATA AND CONNECTIONS FOR THE DZ10 TUBE

Max. counting speed (kc/s)	3	<i>Base</i>				
Striking voltage	160-200	14 pin Diheptal				
Maintaining voltage	110-115					
Anode current (mA)	2-8					
Anode supply voltage	220-400					
Max. output voltage	35					
Min. reset or preset voltage	80	<i>Connections</i>				
Transfer voltage between two adjacent cathodes	25-80	Pin	1	2	3	4
Min. length of input pulse (μsec)	150	Electrode	<i>K</i> ₁	<i>B</i> ₁	<i>K</i> ₀	<i>K</i> ₉
Max. slope of leading edge of input pulse (V/sec)	10 ⁶	Pin	5	6	7	8
		Electrode	<i>a</i>	<i>K</i> ₈	<i>K</i> ₇	<i>K</i> ₆
<i>Typical Operating Conditions</i>		Pin	9	10	11	12
Anode supply voltage	300	Electrode	<i>B</i> ₂	<i>K</i> ₅	<i>K</i> ₄	<i>a</i>
Anode current (mA)	4	Pin	13	14		
Anode resistor (kΩ)	47	Electrode	<i>K</i> ₃	<i>K</i> ₂		
Cathode resistor (kΩ)	3.3					
Cathode capacitor (for 3 kc/s stages) (μF)	0.25					
Output voltage	13					
Input pulse amplitude	50					
Transfer electrode bias	+30					
<i>Dimensions</i>						
seated height 90 mm (max.)		Diameter				
		56 mm (max.)				

(The DZ10 tube is now recommended for maintenance purposes only).

4.7 THE G10/241E 'NOMOTRON' TUBE AND ITS CIRCUITS

The 20 kc/s G10/241E decade selector tube, also known by the name of 'Nomotron', is manufactured by the Special Valve Division of Standard Telephones & Cables Ltd.⁽²⁸⁾. The Nomotron tube contains ten main cathodes equally spaced in a circle, one transfer cathode being placed between each two main cathodes. The electrode structure of the main cathodes has been made asymmetrical so that the discharge is able to move only in the forward direction from a main cathode to the succeeding transfer electrode. The asymmetry of the transfer electrodes ensures maximum priming in the forward direction. Each main cathode is connected to a separate base pin, but all of the transfer electrodes are joined to one common base pin. The Nomotron requires a higher current than the double pulse tubes, but a lower supply voltage is permissible. The current passed by the tube is sufficient to operate a relay directly.

The structure of the tube is shown in Fig. 4.46. The anode consists of a cylindrical cup placed around the cathodes. A shield is also used to limit the glow to the desired part of the tube; it confines the discharge to the front surface of the main cath-

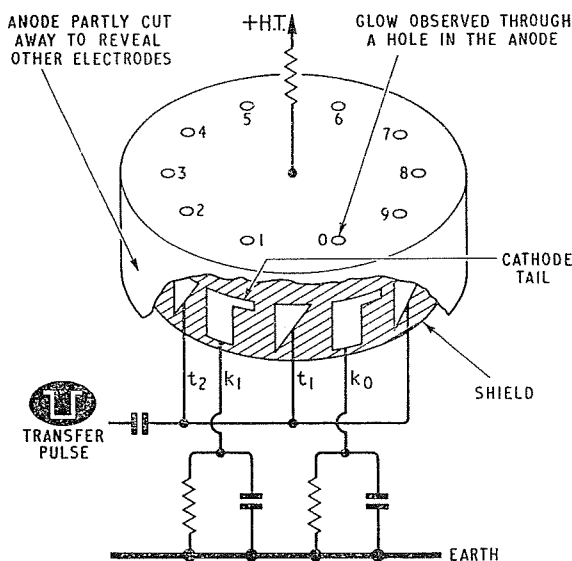

Fig. 4.46 The structure of the S.T.C. G10/241E Nomotron decade tube

odes and transfer electrodes. The glow is observed through one of ten small holes in the anode. The asymmetrical shape of the cathodes can be clearly seen in Fig. 4.46.

In operation the shield receives a positive bias of between 75 and 110 V, whilst the transfer electrodes receive a bias of about +90 V (see table of tube data). The tube is not sensitive to light and may be used in bright light or darkness without its characteristics being affected.

If the glow is resting at K_0 when a suitable pulse is applied to the transfer electrodes, the discharge will spread to the most strongly primed transfer electrode, that is to t_1 . As the potential of t_1 falls with the applied pulse, the anode voltage of the tube will fall also so that the voltage between these electrodes remains constant at the maintaining voltage of the tube. The fall of anode voltage results in the discharge at K_0 being extinguished.

At the end of the input pulse the transfer electrodes return to their normal bias potential. The cathode which was previously glowing (K_0) will still be at a positive potential with respect to earth owing to the charge held by the cathode capacitor. The discharge, therefore, moves to the most strongly primed electrode which is not positively biased, that is to K_1 . The discharge moves to the 'tail' of K_1 initially, but quickly moves to the main part of the cathode, since a high current concentration at the small tail area would result in a greater maintaining voltage than normal. The next transfer cathode is then primed by the discharge.

4.7.1 Cathode Circuit Time Constants

The decay of the voltage across the cathode capacitor after the discharge has left the corresponding main cathode occurs exponentially with a time constant $C_k R_k$, the cathode capacitor C_k discharging through the cathode resistor, R_k . When the discharge comes to rest at a main cathode, the corresponding cathode capacitor commences to charge. The a.c. resistance of the tube and of the power supply are negligible compared with R_k and the anode resistor, R_a . If steady voltages are ignored and only voltage changes are considered, the anode resistor and the cathode resistor may, therefore,

be considered to be in parallel with the cathode capacitor which thus charges with a time constant of

$$\frac{R_a R_k}{R_a + R_k} C_k.$$

The minimum value of the cathode capacitor is determined by the requirement that the cathode potential shall remain above 33 V until the end of the input pulse to the transfer electrodes so as to ensure that the discharge does not return to the main cathode which was previously glowing. The maximum value of the cathode capacitor is determined by the requirement that the voltage across it shall have decayed to less than five volts before the discharge arrives at that cathode again; otherwise the discharge may not transfer to that cathode easily.

5 V during the period in which the discharge rests at the other cathodes. Subject to this condition, the main cathodes K_1 , K_3 , K_5 and K_7 may be connected together and returned to earth through a single common resistance-capacitance circuit. By connecting alternate main cathodes together in this way some economy may be effected. Any cathode from which an output pulse is required, normally K_9 , must obviously have its own parallel resistance-capacitance circuit to earth.

4.7.2 5 Kc/s Circuit

The basic circuit for operating a Nomotron tube at frequencies up to 5 kc/s is shown in Fig. 4.47⁽²⁸⁾. The positive bias potentials for the transfer electro-

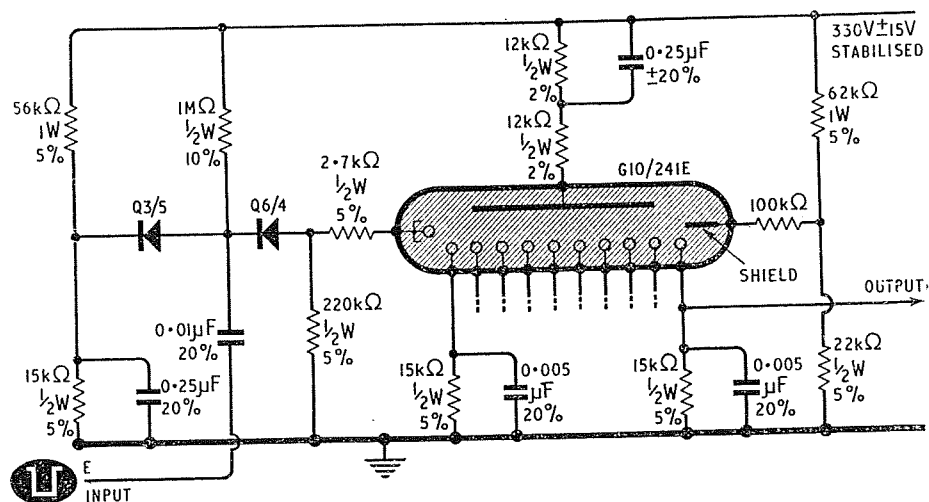

Fig. 4.47 The circuit recommended for the operation of the G10/241E up to 5 kc/s

The value of the cathode capacitor used should be the maximum permitted for the speed required (see table of data), but should not normally exceed 0.1 μF . If it is necessary that the value of the cathode capacitor should be greater than this, the capacitor in the anode circuit should be omitted so that extended current surges are avoided.

In simple straightforward counting circuits it is unnecessary to employ more than three parallel resistance-capacitance cathode circuits provided that the charge on each capacitor decays to less than

des and for the shield are obtained from the potential dividers shown. The input pulses are fed to the transfer electrodes via the Sen Ter Cel 'Unistor' type Q6/4 which isolates the input circuit from the transfer electrode during the quiescent period and permits a condition of bias equilibrium across the transfer leak resistor.

During the time that the pulse is applied, the Q6/4 is, of course, in its conducting state. The unistor type Q3/5 is used to provide d.c. restoration of the applied pulses.

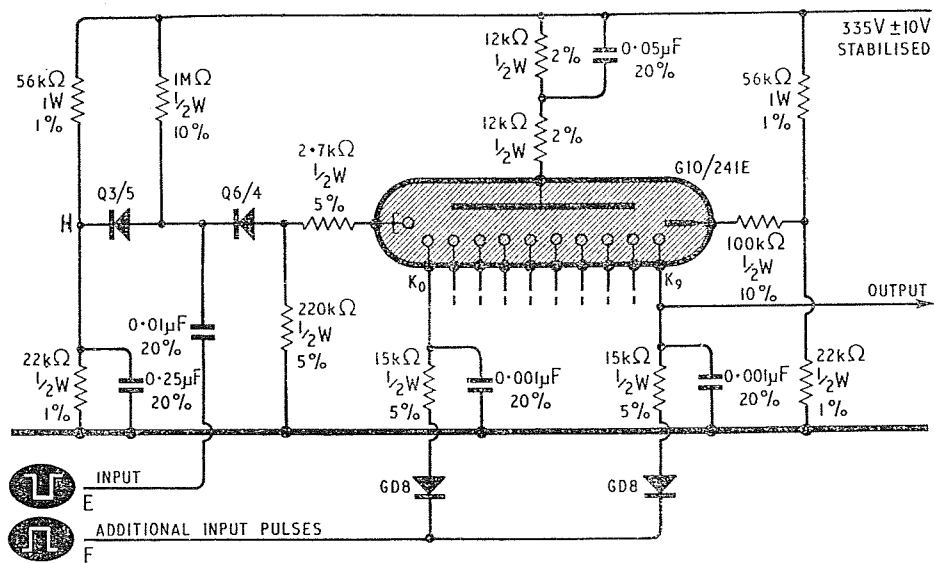

Fig. 4.48 A Nomotron 20 kc/s circuit

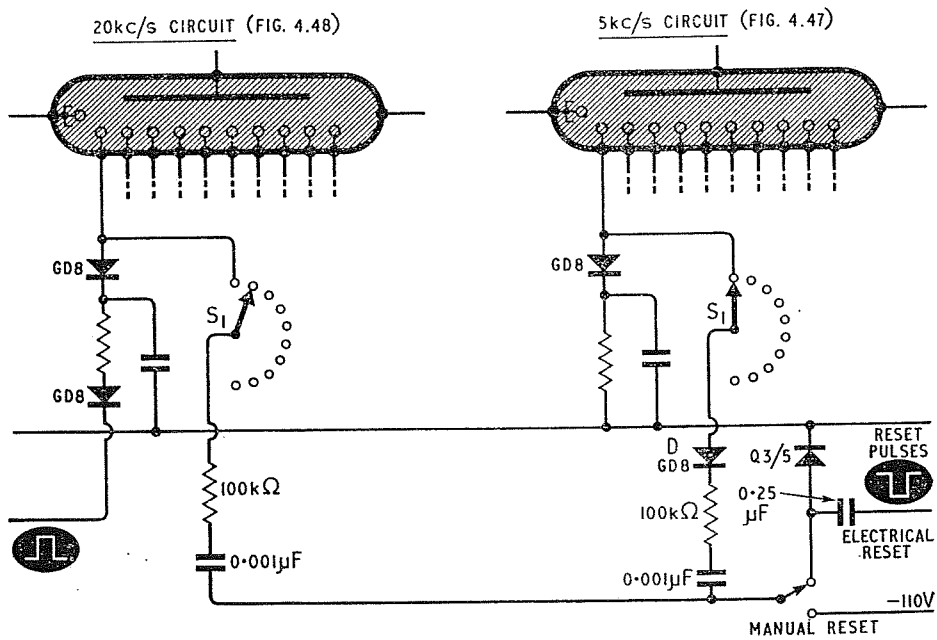

Fig. 4.49 Two methods of resetting Nomotron circuits

4.7.3 Input Pulse Requirements

The input pulse should be of sufficient amplitude to reduce the anode to earth potential to less than 60 V and its duration should be great enough to ensure that the discharge can spread across the surface of the transfer electrode during the time that the pulse lasts. Whilst it is desirable that the pulse should be fairly long, its duration must be related to the cathode circuit time constants so as to ensure that there is a potential of at least 33 V at the previously conducting main cathode when the input pulse terminates.

The effective duration of the pulse is from the time the anode potential commences to fall to the time at which the anode to earth potential rises to 180 V. When this potential is reached the anode current will commence to flow to the next main cathode.

The minimum input pulse duration is determined by the rate at which the discharge spreads over the surface of the transfer electrode. If the internal impedance of the source of the transfer pulses is kept small, the minimum pulse duration is approximately 4 μ sec. Generally 120 V (± 15 V) rectangular negative going pulses of 16 ± 4 μ sec in duration are recommended.

Fig. 4.47, with the Nomotron inserted, presents an impedance of about 13 k Ω to the pulse source; the latter should be matched to this impedance.

4.7.4 20 Kc/s Circuit

Whilst satisfactory results may be achieved with the Nomotron circuit of Fig. 4.47 at frequencies above 5 kc/s, it is necessary to make the time constant of the cathode components so short that the duration of the transfer pulse must be reduced to a point at which reliability may be impaired.

This difficulty may be overcome by the use of the circuit of Fig. 4.48 in which the Nomotron can operate at frequencies up to 20 kc/s⁽²⁸⁾. Although cathode circuits of short time constant are employed, the discharge of the cathode capacitors is prevented until the end of the input pulse by means of an additional positive going input pulse applied to the cathodes as shown in the circuit. The two input pulses occur simultaneously and are of the same duration; they may be generated by the circuit of

Fig. 4.50 or alternatively a pulse transformer or a paraphase amplifier may be employed.

The transfer electrodes of Fig. 4.48 should be fed with rectangular negative going pulses of 120 ± 15 V in amplitude and of 10 ± 2 μ sec in duration. The auxiliary positive going pulses fed to the cathode circuit should be of 50 ± 5 V in amplitude and of 10 ± 2 μ sec in duration; they should be obtained from a circuit of internal impedance not exceeding 5 k Ω to earth.

The shield electrode may be connected via a 100 k Ω resistor to point *H* instead of as shown in the circuit of Fig. 4.48, thus eliminating the potential divider resistors in the shield circuit.

Prolonged conduction at one cathode of a Nomotron should, where possible, be avoided. If this type of operation is unavoidable, a value of cathode current close to the minimum should be chosen and it is preferable that the discharge in the tube should be circulated from time to time at any frequency between 50 and 5,000 c/s.

Reset

The recommended circuit for the resetting of Nomotron tubes is shown in Fig. 4.49⁽²⁸⁾. The resetting operation can be made to take place either manually or automatically by means of a suitable pulse. The cathode circuit of the Nomotron on the left-hand side of Fig. 4.49 is arranged for operation at up to 20 kc/s, whilst that on the right-hand side is for use at up to 5 kc/s. A selector switch is shown in the cathode circuit of each tube; it enables the discharge to be reset to any desired cathode — a facility which is useful when articles are being batched. In simple counting circuits where the tubes are always reset to zero, the selector switch may be omitted. If a positive pulse is used to delay the discharging of the cathode capacitor in the first Nomotron stage for 20 kc/s operation, an isolating diode (marked *D* in Fig. 4.49) is required in each subsequent stage.

If the reset switch is pressed to the manual position, a negative pulse passes from the -110 V line to the selected cathode circuits. If electrical reset is required, a negative pulse of -150 ± 20 V in amplitude and about 30 μ sec in duration should be applied to the reset pulse input.

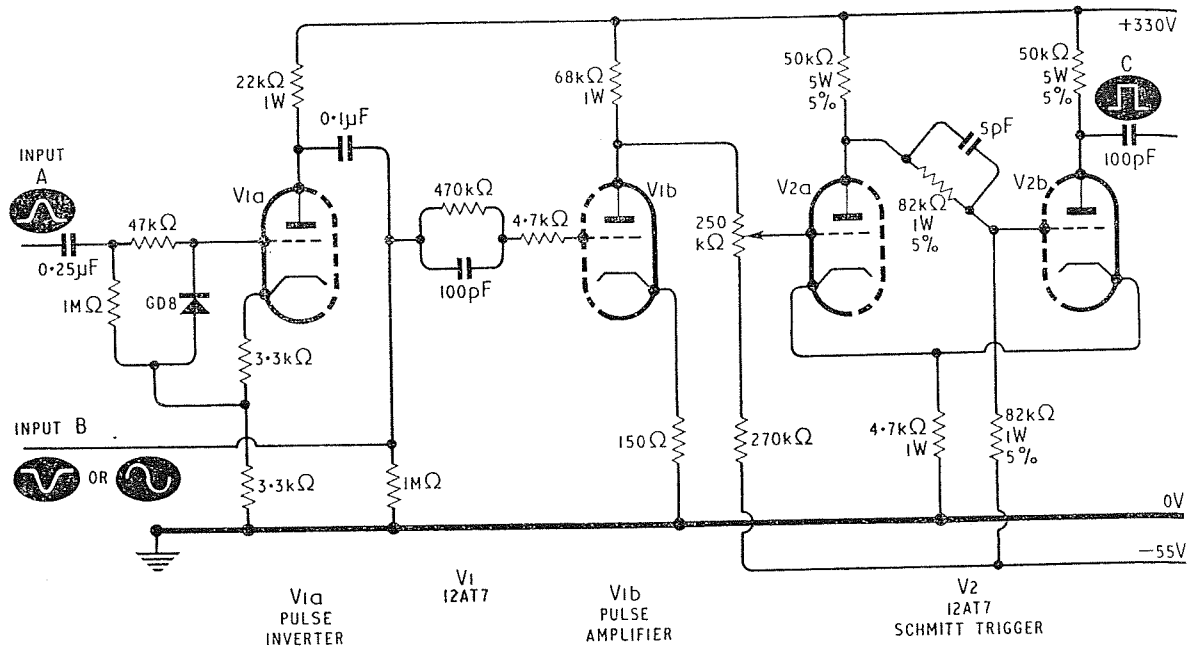

Fig. 4.50 An input circuit for feeding

4.7.5 Input Circuit ⁽²⁸⁾

The pulses which are required for the operation of the circuits of Figs. 4.47 and 4.48 may be obtained from the circuit of Fig. 4.50. Four 12AT7 double triode valves are used in this input circuit. If the pulses to be counted are positive going, they should be applied to the input terminal *A*; they are inverted in phase by *V1a* and the resulting negative going pulses are fed into the pulse amplifier *V1b*. If sine waves or negative going pulses are to be counted, the input may be fed directly into *V1b* by using the input *B*. *V1b* is a d.c. coupled amplifier which permits input waveforms of low amplitude (down to 5 V peak) and low rates of rise to be used.

The output from *V1b* is fed into the Schmitt trigger circuit *V2a* and *V2b* which converts the pulse into a rectangular waveform of short rise time. The voltages at the grid of *V2a* should be set so that the trigger circuit operates from the input signals but not from stray signals such as mains hum. The 'speeding up' capacitor shunting the resistor between the anode of *V2a* and the grid of *V2b* must be very small if the input waveform is not to distort the sharp corners of the output waveform from *V2b* (shown at *C*).

The positive going output pulses from the Schmitt trigger circuit are fed via a differentiating network into *V3a*. *V3* is a flip-flop circuit which adjusts the duration of the pulses to approximately 16 μsec. The output pulse amplitude from *V3b* at point *D* is about 75 V. If the input which is to be counted consists of discrete positive going pulses with a rate of rise of the leading edge exceeding 40 V/μsec, the circuits of *V1* and *V2* can be omitted and the input can be fed directly into the differentiating capacitor and resistor in the grid circuit of *V3a*.

The positive going pulses from the point marked *D* in Fig. 4.50 are fed into the grids of the driver stage, *V4a* and *V4b*. *V4b* provides the negative going pulses at output *E* for feeding to the transfer electrodes of the Nomotrons in Figs. 4.47 and 4.48. *V4a* is a cathode follower which provides the positive going pulses at output *F* which are required for the operation of the 20 kc/s circuit of Fig. 4.48; it also provides the positive pulses required to drive hard valve coupling stages.

If it is required to gate the input, a suitable valve such as the short suppressor base pentode type 6F33 or the heptode type 7032 may be used in the

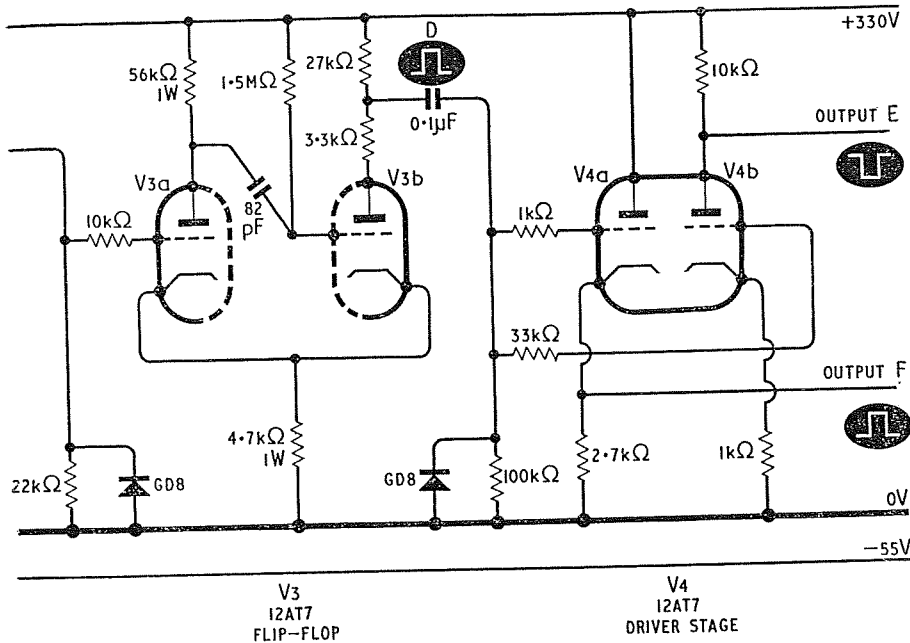

the circuit of Figs. 4.44 and 4.45

circuit. If the input pulses are positive going, it is often convenient to replace $V1a$ by the gating valve. Alternatively the gating valve may be inserted between the flip-flop ($V3$) and the driver stage ($V4$). If the tube type 7032 is used, care should be taken that the anode and screen voltage rating are not exceeded. Precautions should also be taken to ensure that gating does not occur during the time in which a transfer pulse is applied to the input.

4.7.6 Hard Valve Coupling Circuit

The hard valve coupling circuit recommended for use with Nomotron tubes is shown in Fig. 4.51⁽²⁸⁾. A negative going pulse for the operation of the succeeding Nomotron is produced at the anode of the coupling valve if and only if all of the gating diodes in the input circuit of the coupling tube receive simultaneous input pulses. One gating diode is connected to the positive pulse line (F in Fig.

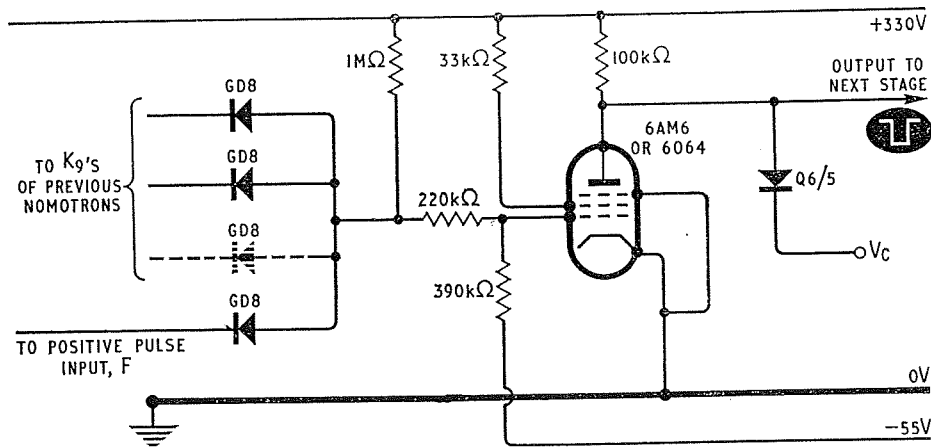

Fig. 4.51 A hard valve circuit for coupling Nomotrons

ELECTRONIC COUNTING CIRCUITS

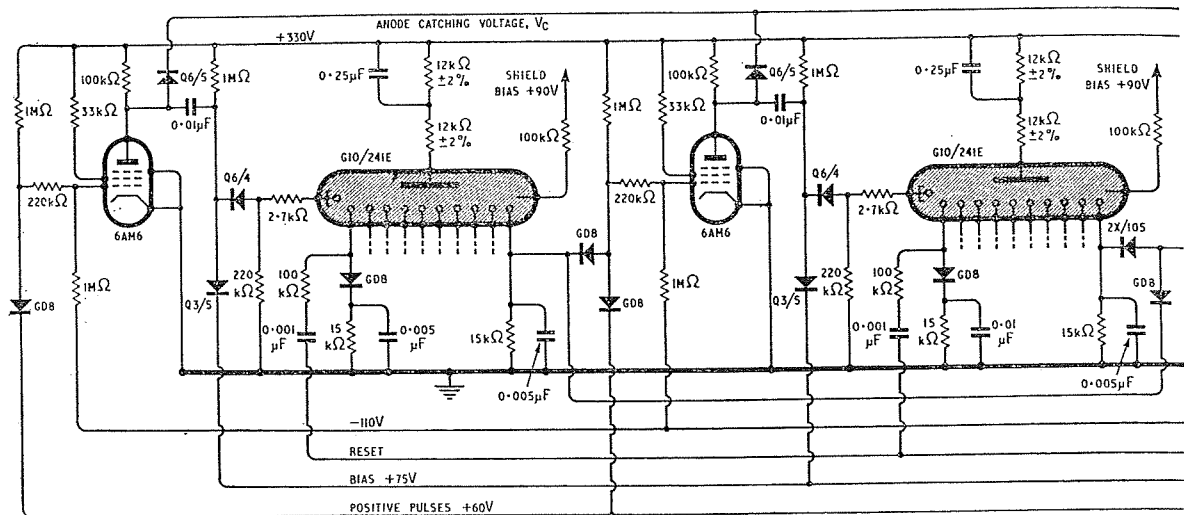

Fig. 4.52 A three decade Nomotron

4.50), whilst each of the remaining diodes are connected to the ninth cathode of one of the preceding Nomotrons.

Positive potentials will be fed to all of the diodes simultaneously only when an input pulse is received at a time when the discharge in each of the preceding Nomotrons is at the ninth cathode. The minimum value of cathode capacitance should be used in the ninth cathode circuits of the Nomotrons in order to avoid double gating. The catching potential, V_c , of the anode circuit should be adjusted so that the output pulse from the coupling circuit has an amplitude of 120 V.

A typical three decade counting circuit employing hard valve coupling is shown in Fig. 4.52⁽²⁸⁾. The impedance of the anode catching voltage supply must be small compared with all of the valve anode resistors connected in parallel. If several decades are to be used, a cathode follower is more economical on power than a potential divider for supplying the required adjustable catching potential. A 6CH6 cathode follower is used in Fig. 4.52.

4.7.7 Trigger Tube Coupling Circuit

The use of the trigger tube circuit of Fig. 4.53 enables a number of Nomotrons to be coupled without the necessity for heater supplies⁽²⁸⁾. This circuit requires input voltages of closer tolerances than

the hard valve coupling circuit. Negative input pulses of 160 V in amplitude which occur simultaneously with the input pulses to the first Nomotron must be fed into the circuit.

The catching potential, V_c , must be adjusted so that the trigger tube anode voltage does not exceed 165 V in the quiescent condition; this is 10 V less than the maintaining voltage, so the tube will be extinguished between successive pulses. The negative input pulses which are applied to the cathode must not be much less than 155 V in amplitude or the output pulses will be too small. On the other hand the input pulses must not exceed 165 V or they may cause spurious triggering.

The output pulse amplitude from the trigger tube coupling circuit is equal to the input pulse amplitude at the cathode plus the catching potential minus the maintaining voltage of the tube.

A three decade circuit using trigger tubes as the coupling amplifiers is shown in Fig. 4.54. The anode catching potential may be obtained from a 6CH6 cathode follower stage as in the hard valve circuit of Fig. 4.52.

4.7.8 Sine Wave Drive

It is not generally recommended that Nomotron tubes should be operated directly from sine waves, since large values of cathode capacitance are requir-

ELECTRONIC COUNTING CIRCUITS

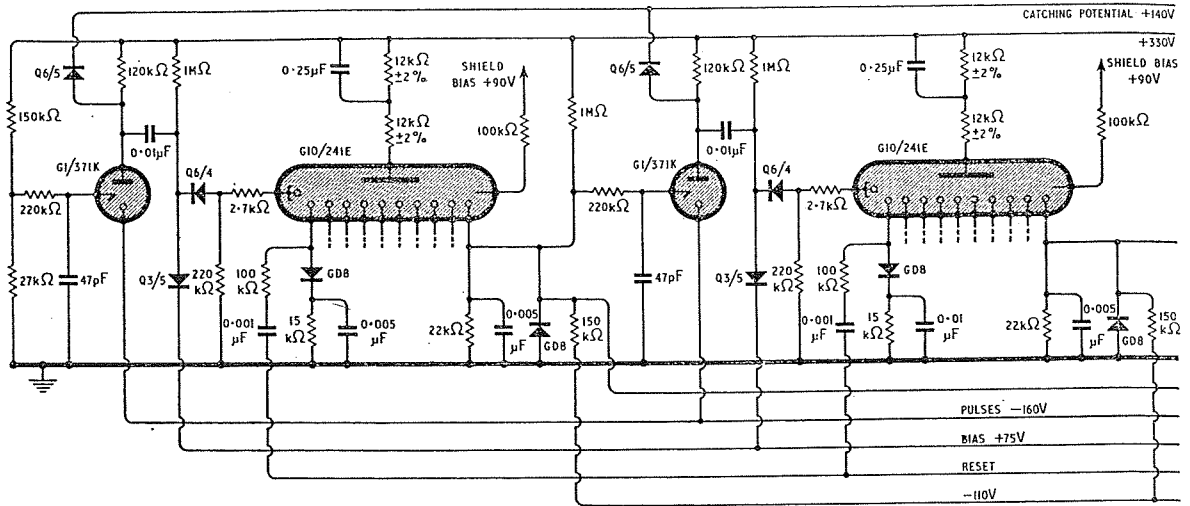

Fig. 4.54 A three decade Nomotron scaler using trigger tube coupling. (Right) connections

in Fig. 4.55. It is very useful in count-down circuits which give an output at a sub-multiple of the mains frequency. The capacitor which normally shunts one of the anode load resistors is omitted in order to avoid an excessive flow of current through the tube. The potential divider which supplies the guide bias may be modified so as to include reactive elements which shift the phase of the cathode waveforms relative to the mains sine wave. If it is desired to isolate the circuit from the mains, the potential divider can be replaced by a transformer with 100 V R.M.S. output; an anode supply voltage of 315 V will then be required.

4.7.9 The Operation of Relays from Nomotrons

The comparatively high cathode current passed by Nomotron tubes (2.4 to 5 mA) enables them to be used to operate a relay directly without any intermediate amplifier. Whilst it is desirable that relays which have a coil resistance approaching 15 kΩ should be used, satisfactory operation can be obtained with the S.T.C. midget relay type 4192AA which has two change over contacts or with the S.T.C. relay type 4600 which is limited to one change over contact. A suitable circuit is shown in Fig. 4.56⁽²⁸⁾.

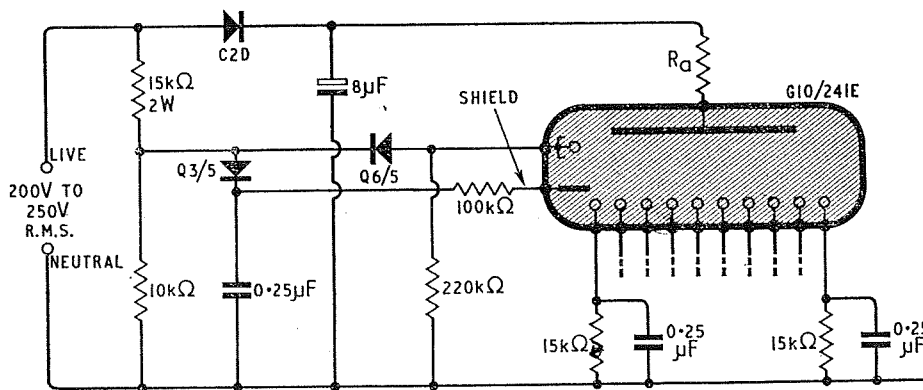
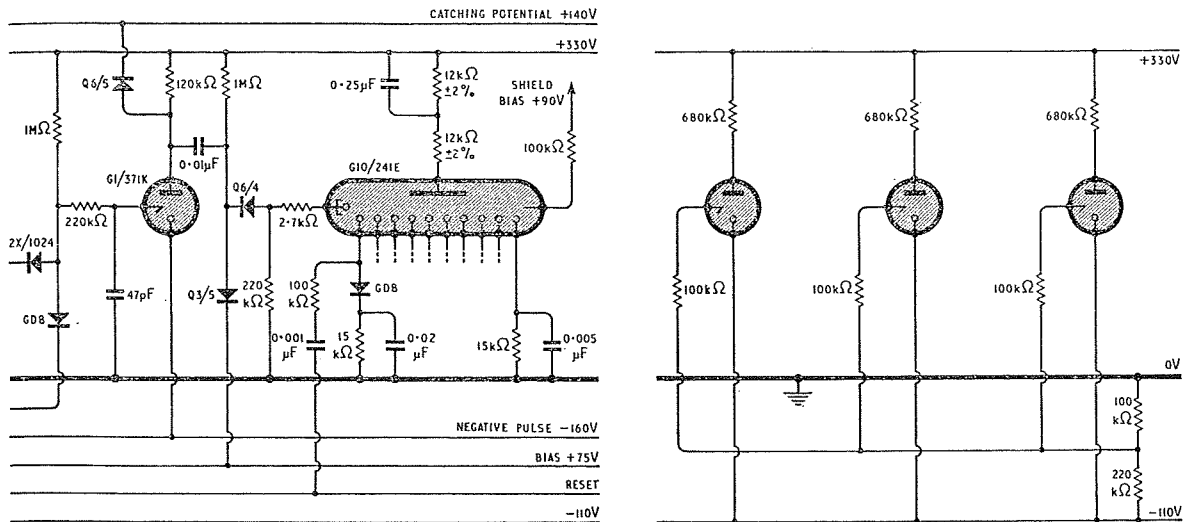

Fig. 4.55 A Nomotron circuit for counting the waveform of 50 or 60 c/s A.C. mains

MULTI-ELECTRODE GAS FILLED TUBES AND THEIR CIRCUITS



to priming gaps and shield electrodes of the trigger tubes—see also Fig. 4. 53

Table 4.8 BASIC DATA FOR THE S.T.C. NOMOTRON, G10/241E (CV2223).

Striking voltage Maintaining voltage	280 V 180 V	<i>Connections</i> Pin 1 2 3 4 5 6 Electrode Shield K_0 K_9 K_8 K_7 K_6 Pin 7 8 9 10 11 12 Electrode K_5 K_4 K_3 K_2 K_1 Transfer cathodes			
<i>Ratings:</i> Minimum H.T. supply voltage Maximum anode voltage relative to any non-conducting cathode Quiescent cathode current Shield bias	310 V 250 V 2.4 – 5 mA 75 – 110 V	Base cap = anode A numbered escutcheon plate around the tube may be used to facilitate readout.			
<i>Typical Operating Conditions:</i>	Maximum Frequency				
Stabilised H.T. voltage Transfer electrode bias Nominal shield bias Anode load (2% tolerance) Anode load capacitor (20%) Cathode load (5%) Cathode capacitor (20%) Input pulse duration Input amplitude Output pulse Cathode current	<i>1 kc/s</i> 315–345 V 75 V 90 V 24 kΩ 0.25 µF 15 kΩ 0.02 µF 15–100 µsec 105–135 V 40 V 3.7 mA	<i>5 kc/s</i> 315–345 V 75 V 90 V 24 kΩ 0.25 µF 15 kΩ 0.005 µF 12–20 µsec 105–135 V 40 V 3.7 mA	<i>20 kc/s</i> 325–345 V 90 V 90 V 24 kΩ 0.05 µF 15 kΩ 0.001 µF 8–12 µsec 105–135 V 40 V 3.7 mA		

Dimensions Seated height 50.8 mm (max.)
 Base B12E (McMurdo type X12E)

Diameter at base: 43.7 mm (max.)

ELECTRONIC COUNTING CIRCUITS

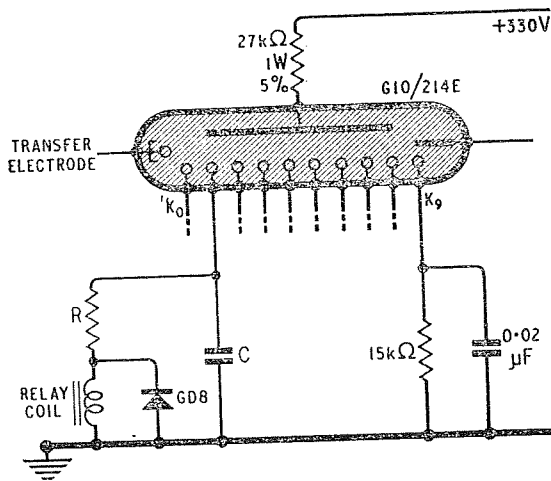

Relay type	Relay Coil resistance	Recommended Values	
		C	R
S.T.C. Midget 4193 AA	6.8 kΩ	0.1 μF	8.2 kΩ
S.T.C. type 4600 Post Office type 3000	6.5 kΩ	0.5 μF	2.2 kΩ

Fig. 4.56 The operation of a magnetic relay from a Nomotron

The inductance of the relay coil reduces the effective time constant of the cathode circuit and a larger capacitor should be employed to compensate for this. A diode should be connected across the relay to prevent oscillations from occurring when the discharge leaves the cathode to which the relay circuit is connected. If such oscillations occurred, the cathode would swing to a negative potential and spurious back stepping of the glow could occur.

The relay could, of course, be used to operate an electro-magnetic counter in order to increase the number of digits which can be displayed without increasing the number of Nomotrons.

4.8 THE ELESTA EZ10B AND ECT100 TUBES AND THEIR CIRCUITS

4.8.1 The EZ10B

The Elesta EZ10B tube is a miniature gas filled decade selector tube which can be used for counting at frequencies up to 1 Mc/s⁽²⁹⁻³¹⁾. A total of 20

cathodes are employed around the cylindrical anode, one transfer cathode being placed between each two main cathodes. All of the cathodes are placed in the tube at an oblique angle (as shown in the photographs) in order that the discharge shall be able to rotate in the forward direction only. When the discharge is resting at a certain main cathode, the succeeding transfer cathode is strongly primed owing to the fact that the oblique angle at which the cathodes are placed results in a small part of the succeeding cathode being in the edge of the discharge region. An appreciable current, known as the probe current, flows to the cathode succeeding the cathode at which the discharge is resting. This assists very rapid transfer of the discharge. The cathode preceding the discharge is not strongly primed.

The gas with which the tube is filled is hydrogen; this has low ionisation and deionisation times and its use, therefore, enables high counting speeds to be attained. The discharge, which gives the visual indication of the count, is blue in colour as opposed to the orange coloured discharge which occurs in most other cold cathode counting tubes. A special type of cathode must be used for tubes filled with hydrogen in order to avoid instability.

All of the main cathodes in the EZ10B are connected to separate base pins, but the transfer cathodes are connected in two groups to two base pins. This is merely for convenience in manufacture and the two groups are normally joined together externally when the tube is being used.

When a negative pulse is applied to the transfer cathodes, the discharge will move to the most strongly primed transfer cathode, that is, to the one succeeding the main cathode at which the discharge was resting previously. At the end of the pulse the transfer cathodes become positive with respect to the main cathodes (owing to the positive bias applied to them) and the discharge will be automatically transferred to the next main cathode.

4.8.2 The EZ10B and the EZ10A

The EZ10B tube has been evolved from the EZ10A tube⁽³¹⁻³⁴⁾ which is now a maintenance type. The structure of the two tubes is very similar, but they

are filled with different gases. The EZ10B can count at frequencies up to about 1 Mc/s whereas the EZ10A is limited to about 300 kc/s. It is most important that the correct circuits should be used for each type of tube. The EZ10A will have a very short operating life if it is used in the circuits which have been designed for the EZ10B (despite the fact that its initial performance will be quite satisfactory). If the EZ10B is used in circuits designed for the EZ10A, faulty counting is likely to occur. The anode current range for satisfactory operation is not the same for the two tubes. The circuits to be described are for use with the current production tube, the EZ10B.

Anode Supply Voltage

In the circuits to be described an anode supply voltage of +580 V is recommended. This is about twice the maintaining voltage of the tube. A fairly high voltage is required to ensure that the anode current remains within the specified working range for all normal mains supply variations. A stabilised supply as low as +450 V may be employed provided that the anode resistor is decreased in value so as to keep the anode current within the specified operating range. The current should be adjusted to 1.5 mA when the discharge is stationary at one cathode.

The anode resistor should be mounted as closely as possible to the tube socket so that stray capacitance is kept as small as possible. If a variable anode resistor is employed so that adjustment can be made for optimum anode current, an additional fixed resistor of at least half the total anode resistance should be mounted close to the tube socket.

Input Pulses

Although the shape and amplitude of the input pulses to the EZ10B are not critical, it is advisable to use the optimum wave forms so that satisfactory operation over a fairly large range of anode current (and hence of anode voltage) is possible. Counting errors due to the changing of the tube characteristics during life are then prevented.

The pulses should be preferably approximately rectangular in shape, since if the input voltage changes slowly, double transfers may occur. The

rate of rise of the leading edge of the input pulse should not exceed 10^9 V/sec, but if input pulses of a comparatively long duration are used, it is advisable to increase the rise and fall times of the input pulses to about 10% of the total pulse length up to a maximum of 1 msec. Rise or fall times exceeding 1 msec may cause double transfers.

A capacitor of about 10–100 pF, may be connected between the transfer cathodes and earth in order to reduce the rate of change of input pulse voltage.

The pulse amplitude should be about 100 to 120 V for counting speeds up to 100 kc/s with a pulse length of not less than 5 μ sec and a transfer cathode bias of about +55 V. Both the pulse amplitude and the transfer cathode bias should be increased with increasing counting speed above 100 kc/s. For counting at up to 500 kc/s the pulses may have an amplitude of 200 V and a duration of 1 μ sec and the transfer bias may be about +80 V. An input pulse amplitude of 220 V and a duration of 0.5 μ sec are recommended for counting speeds of up to 1 Mc/s with a transfer cathode bias of +120 V. The pulse amplitude should be adjusted for optimum performance when the tube is used at frequencies approaching 1 Mc/s.

Cathode Circuits

Capacitors should be placed in parallel with the cathode resistors in circuits which are intended for use at very high speeds. A cathode will then remain at a positive potential for a short time after it has ceased to conduct. This reduces the possibility of a transfer of the discharge in the reverse direction. In addition, the capacitors in parallel with the cathode resistors absorb any spurious pulses which may be coupled into the cathode circuits from the steep edges of the drive pulses by stray capacitance.

Output Pulses

The main output pulse has an amplitude of approximately 7 V, but it is preceded by a smaller positive going rectangular pulse of about 2 V in amplitude. The smaller pulse is caused by the flow of the 'probe' current through the resistor in the main cathode circuit during the time the discharge rests momentarily at the preceding transfer cathode.

ELECTRONIC COUNTING CIRCUITS

The duration of the 2 V output pulse is equal to the duration of the input transfer pulse.

Two methods may be used to prevent the preliminary 2 V step from causing double triggering of the succeeding stage. The simplest method involves

Tolerances

The tolerances of the resistors and capacitors in the EZ10B circuits to be discussed are $\pm 10\%$ unless otherwise stated. The capacitors may be rated at 400 V d.c. working and the resistors may be $\frac{1}{2}$ W

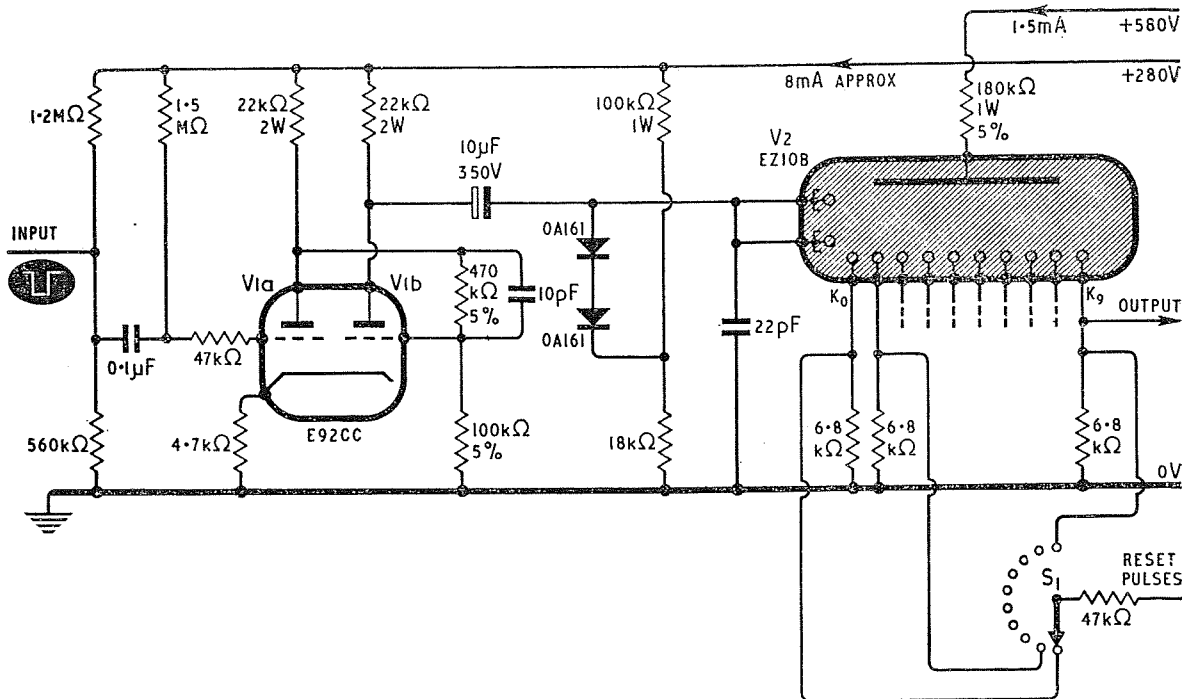

Fig. 4.57 A 100 kc/s circuit for the EZ10B tube

the differentiation of the output pulse by means of a coupling capacitor; the negative peaks thus produced at the end of the cathode pulses may be used to trigger the following driver stage of the next decade. The output pulse must be taken from the ninth cathode of the EZ10B. This method is used in the circuits to be described and has the advantage that the output pulse is little delayed.

The second method involves the use of a series diode connected to a suitable bias supply. The diode passes only those pulses which exceed 2 V in amplitude. When this method is employed, the positive going output pulses must be taken from the zero cathode of the EZ10B; they may be used to control PNP transistors which are used as the pulse amplifiers.

size unless otherwise indicated. The supply voltages may vary from -10% to $+15\%$ of the stated value except in the case of the high speed circuits requiring stabilised supplies.

100 kc/s Input Circuit⁽²⁹⁾

The input circuit of Fig. 4.57 can be used for counting at up to 100 kc/s. The left-hand triode of the E92CC, V1a, is normally conducting, since its grid is connected to the positive H.T. line via two resistors. A suitable negative pulse applied to the input cuts off V1a and causes V1b to become fully conducting. The resulting negative going rectangular pulse at the anode of V1b is fed to the transfer electrodes of the EZ10B.

The 0.1 μF capacitor and the 1.5 MΩ resistor in the input circuit impose a lower limit on the

rate of rise of the input waveform. The input pulse must reach an amplitude of 30 V within 0.05 sec if it is to be counted. The pulse duration is limited to 0.1 sec. If sine waves of amplitude 40 V R.M.S. are applied at the input, the minimum frequency of operation is approximately 1 c/s.

The 10 μ F electrolytic capacitor which couples the anode of $V1b$ to the EZ10B should have a low leakage current. The large value is necessary in order that the longest pulses shall be transmitted without too much distortion. In this way an undesirable slow voltage rise at the transfer cathodes at the end of the pulse is avoided. Smaller input and drive pulse coupling capacitors may be used if the input consists of short pulses or of pulses with steep fronts.

A potential divider is used to provide the bias voltage for the transfer electrodes. The OA161 diodes are used to clamp the transfer electrode potential to the bias voltage. The 22 pF capacitor from the transfer electrodes to earth prevents these electrodes from changing in potential very rapidly.

The tube may be reset to any desired digit by selecting the appropriate cathode by means of the selector switch and applying a resetting pulse. If the 47 k Ω resistor in the reset line is replaced by a diode, output pulses may be taken from any desired cathode. If the tube is to be used for simple counting, the reset line may be connected via the 47 k Ω resistor to the zero cathode, the switch S_1 being omitted.

If a photoelectric pick-up is to be used, a Siemens photodiode type TP 50 may be connected across the input. A counting speed of 10 kc/s can then be attained if the light is of sufficient intensity and if not more than three feet of a low capacity cable is used to connect the diode.

500 kc/s Input Circuit⁽²⁹⁾

An input circuit which is very similar to that described previously can be used for counting at frequencies up to 500 kc/s provided that a stabilised power supply is employed. This type of circuit is shown in Fig. 4.58. The left hand triode of the E182CC is normally conducting, but if a suitable negative pulse is applied to the grid of $V1a$, the

other triode, $V1b$ conducts and a negative rectangular pulse is thus produced at the anode of $V1b$. This pulse is fed to the EZ10B transfer electrodes by means of the coupling capacitor. The inductance of approximately 3.7 mH in the anode circuit of $V1b$ is used to compensate for the circuit capacities and ensures that pulses fed to the counting tube have a constant amplitude up to the maximum frequency at which the circuit is designed to operate. The two diodes in the grid circuit of $V1a$ prevent this tube from taking excessive positive grid current.

A -140 V supply is required. This may be obtained from a 120 V a.c. supply from a transformer as shown in the circuit. Any suitable diode may be used for D . The resistor R should be chosen so that the negative supply voltage is -140 V.

At high counting speeds the input pulses should have a fairly large amplitude. The steep fronts of these pulses are coupled to some extent through the tube and wiring capacities to the output cathodes and mask the wanted signal. In order to suppress these spurious pulses, pulses of opposite polarity to those fed to the transfer electrodes are taken from the anode of $V1a$ and fed through an RC network (39 k Ω , 2 pF) to the output cathode. The spurious pulses are thus cancelled out and the output pulses may be used to operate the succeeding decade. It may be necessary to find the optimum values of the RC network by experiment for the particular circuit layout used.

The two diodes in the circuit of the output cathode prevent negative pulses from being fed along the output line to the next decade. Small capacitors are placed in parallel with the cathode resistors for the reasons discussed previously.

The satisfactory operation of the circuit is not very dependent on the shape of the input pulses. The amplitude of the pulses fed to the circuit should be between -30 and -100 V and their duration must be not less than 0.5 μ sec. The circuit layout and wiring must, of course, conform to the standards normally used for microsecond pulse circuits.

1 Mc/s Input Circuit⁽²⁹⁾

The design and operation of EZ10B circuits which are intended for use at the maximum operating

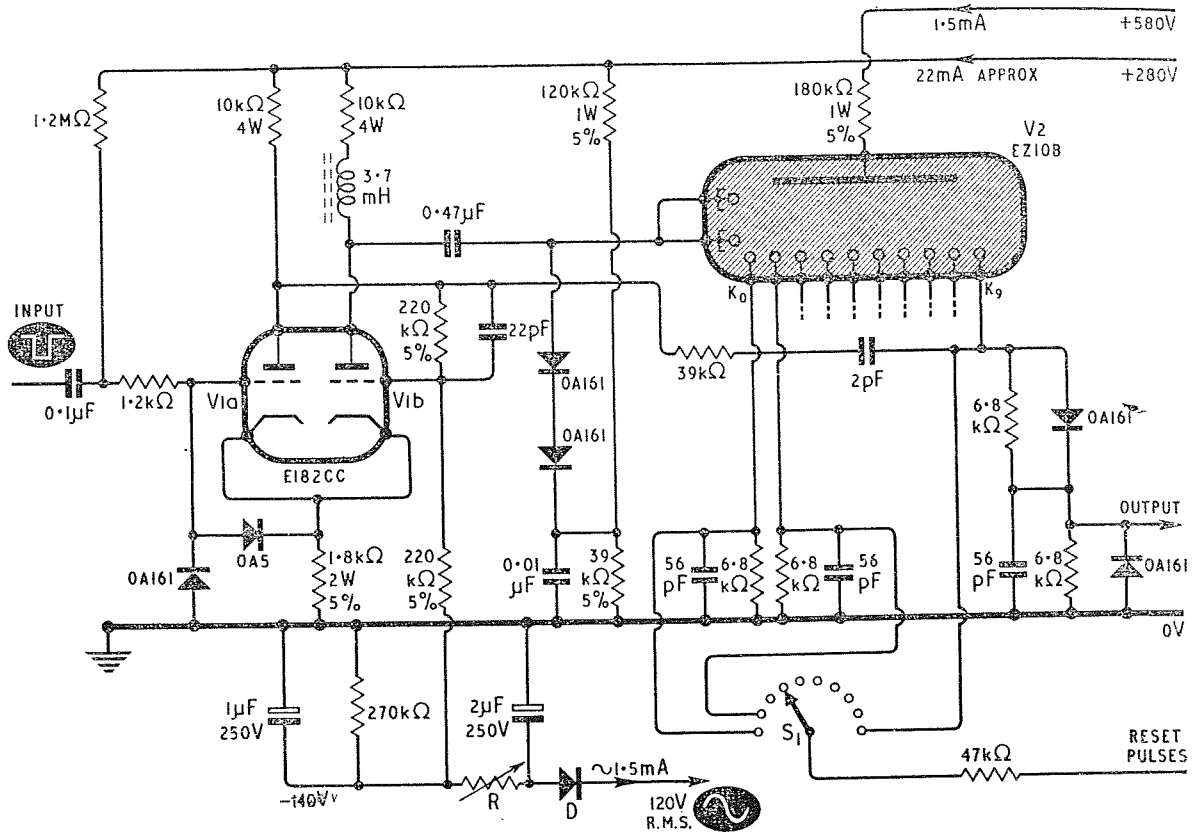

Fig. 4.58 A 500 kc/s circuit for the EZ10B tube

frequency of the tube are somewhat more critical than in circuits used for lower speed operation. The recommended circuit is shown in Fig. 4.59. A stabilised power supply is required for reliability. The input pulses to this circuit should be approximately rectangular in shape and should have an amplitude of not less than -20 V. The input pulse duration should be between $0.5 \mu\text{sec}$ and 25msec . Such pulses may be obtained from a suitable monostable circuit such as a Schmitt trigger circuit.

The input pulses are fed to the grid of $V1a$, the OA161 diode in the input circuit preventing the grid of this triode from becoming positive when the trailing edge of the input pulse is fed to the circuit. For short pulses the anode load of $V1a$ is effectively $2.2 \text{k}\Omega$. Pulses are fed from the anode to the grid of $V1b$ which has a bias of -16 V. The negative going pulses from the anode of $V1b$ are fed to the transfer electrodes of the counting tube. The diodes in the transfer electrode circuit are used

to clamp the pulses to the desired bias voltage and to limit their amplitude to the optimum value. Pulses are also fed from the anode of $V1a$ to the output cathode of the EZ10B for the same purpose as in the circuit of Fig. 4.58; the coupling resistor and capacitor should be adjusted for the particular circuit layout being used.

The anode current should be adjusted so that the value used is in the centre of the range over which the tube operates satisfactorily. The input pulse amplitude should also be adjusted for satisfactory operation over the largest possible anode current range. These adjustments must be repeated each time the EZ10B tube is replaced.

Coupling Circuits⁽²⁹⁾

Coupling circuits which can be used at up to 1kc/s or at up to 10kc/s are shown in Fig. 4.60. The circuit of Fig. 4.57 may be used as the preceding circuit and will, of course, operate at ten times the

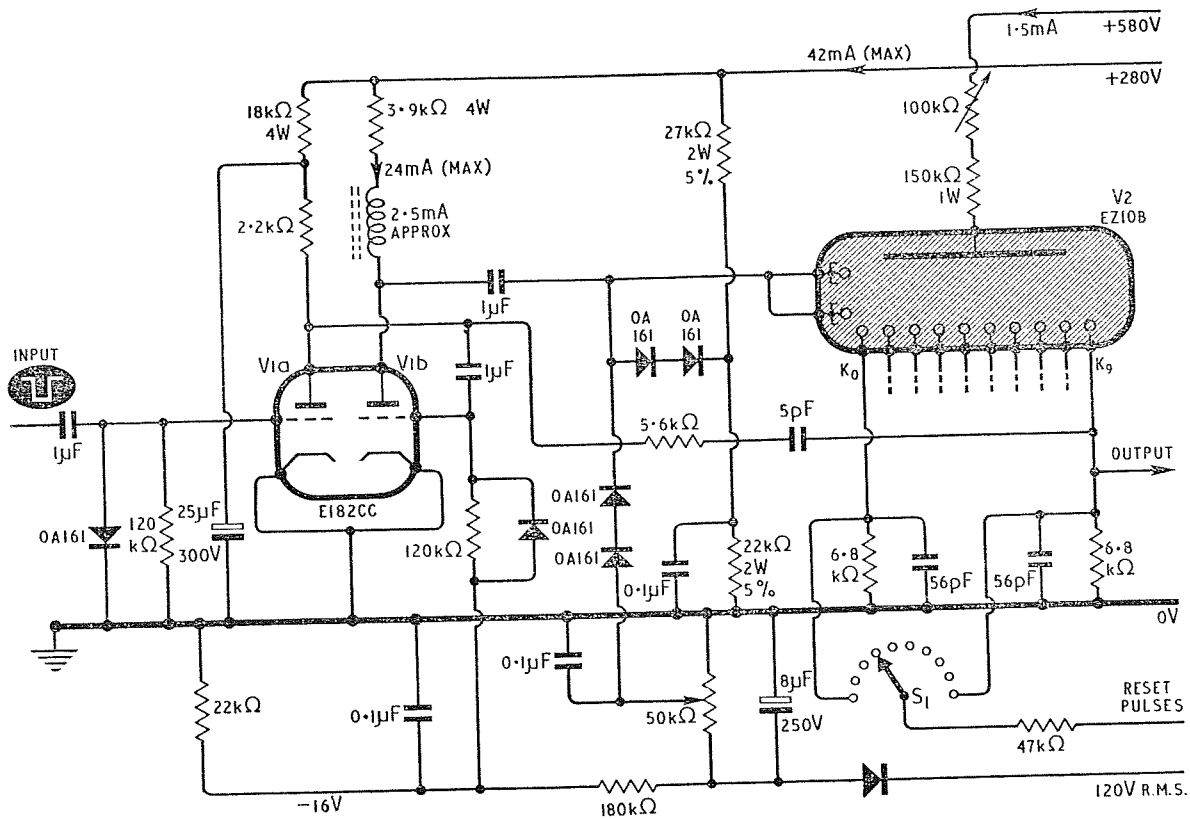

Fig. 4.59 A 1 Mc/s input circuit for the EZ10B

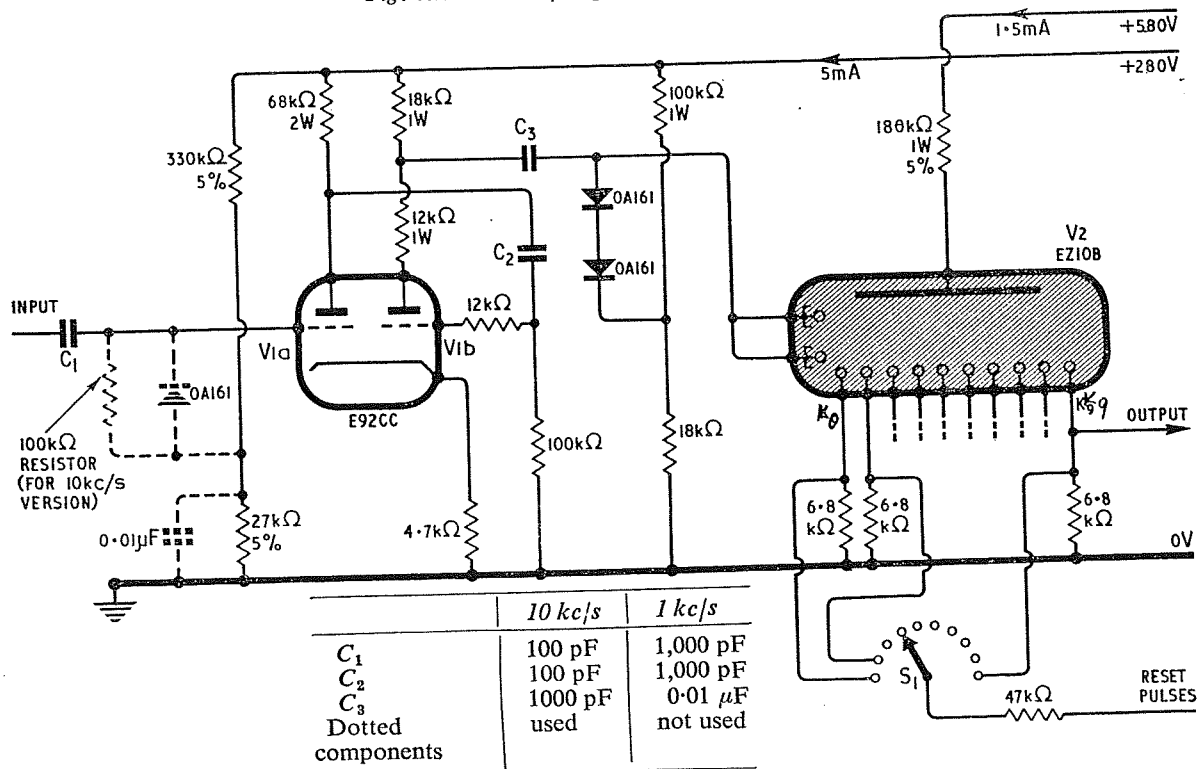

Fig. 4.60 EZ10B circuits for coupling frequencies of up to 1 kc/s or up to 10 kc/s

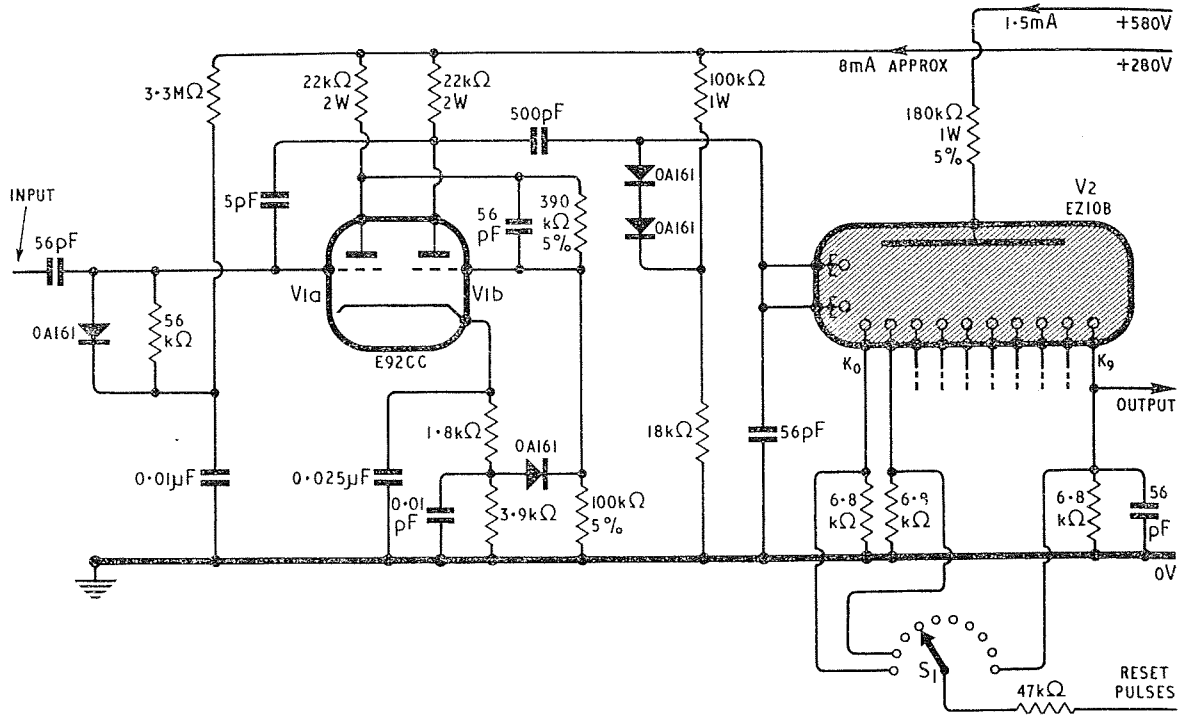

Fig. 4.61 A 100 kc/s coupling stage for the EZ10B

rate at which the coupling circuit operates. Any number of identical coupling circuits may be cascaded.

The 1 kc/s version of the circuit of Fig. 4.60 requires three components fewer than the 10 kc/s version. In addition it is less critical in design and operation and is therefore to be preferred for use at operating speeds of less than 1 kc/s.

The capacitor C_1 and the input resistor serve to differentiate the output pulses from the ninth cathode of the previous counting tube. The extra components shown dotted decrease the charging time of C_1 for high frequency operation.

V1 is a cathode coupled multivibrator, V1a normally being in the conducting state. The negative pulses formed by differentiation of the input pulses cause V1a to be cut off and the resulting pulse from V1b is used to operate the counting tube. The duration of the pulse fed to the EZ10B is determined by C_2 and the associated resistors.

100 kc/s Coupling Circuit⁽²⁹⁾

The circuit of Fig. 4.61 can be used at frequencies of up to 100 kc/s and is therefore suitable for use

after the high speed circuits of Figs. 4.58 and 4.59. It contains a monostable multivibrator in which V1a is normally conducting. The circuit has a very high sensitivity and can be triggered reliably with negative input pulses of 2 V peak amplitude.

The input pulses are differentiated in the input of the circuit of Fig. 4.61. In order to obtain the desired sensitivity of 2 V, the grid of the second triode is connected through a diode to a bias voltage produced by the flow of current through a part of the cathode resistor of the tube. Thus the negative peaks of the grid potential of V1b are limited to the optimum value.

The duration of the pulses fed to the EZ10B is determined mainly by the value of the 5 pF capacitor which is connected from the anode of V1b to the grid of V1a.

Relay Output Circuit, Reset Circuit and Power Supply Unit⁽²⁹⁾

If a relay or electro-magnetic counter is to be used in the output stage of a scaler employing EZ10B tubes, its coil can be fed from the E92CC multivibrator circuit shown in Fig. 4.62. The capacitor

MULTI-ELECTRODE GAS FILLED TUBES AND THEIR CIRCUITS

C_1 may be adjusted in value from about 0.01 to 0.5 μF in order to obtain pulses of optimum duration for the operation of the particular relay or counter employed. The negative going input pulses should have an amplitude, however, of not less than 4 V.

The reset or predetermining pulses are obtained by the discharging of the 0.25 μF capacitor which is in the reset line. This capacitor is normally connected to the +580 V line via the 1 M Ω resistor. When the manual reset button is pressed, one side of the capacitor is connected to earth via the 100 Ω resistor and a negative pulse is applied to the reset line. The resistors and capacitors in the reset circuit damp any oscillations due to contact bounce. An additional contact must be employed on the manual reset switch if a relay or electro-magnetic counter is

used in the output stage. This contact isolates the relay and the anode of $V1b$ of Fig. 4.62 from the H.T. supply during the resetting operation so that the pulse produced when the final EZ10B tube is reset does not operate the relay or magnetic counter. In general, proper resetting is possible only if the reset pulses are of longer duration than the longest drive pulses employed.

Variable resistors may be employed in the power supply unit (as shown in Fig. 4.62) so that the anode supply potentials may be adjusted to the optimum values. If mains voltage variations greater than -15% or +10% of the nominal value are likely to occur, the use of a magnetic voltage stabilising circuit is recommended.

The relay circuit of Fig. 4.62 is very convenient when a predetermined number of objects are to be

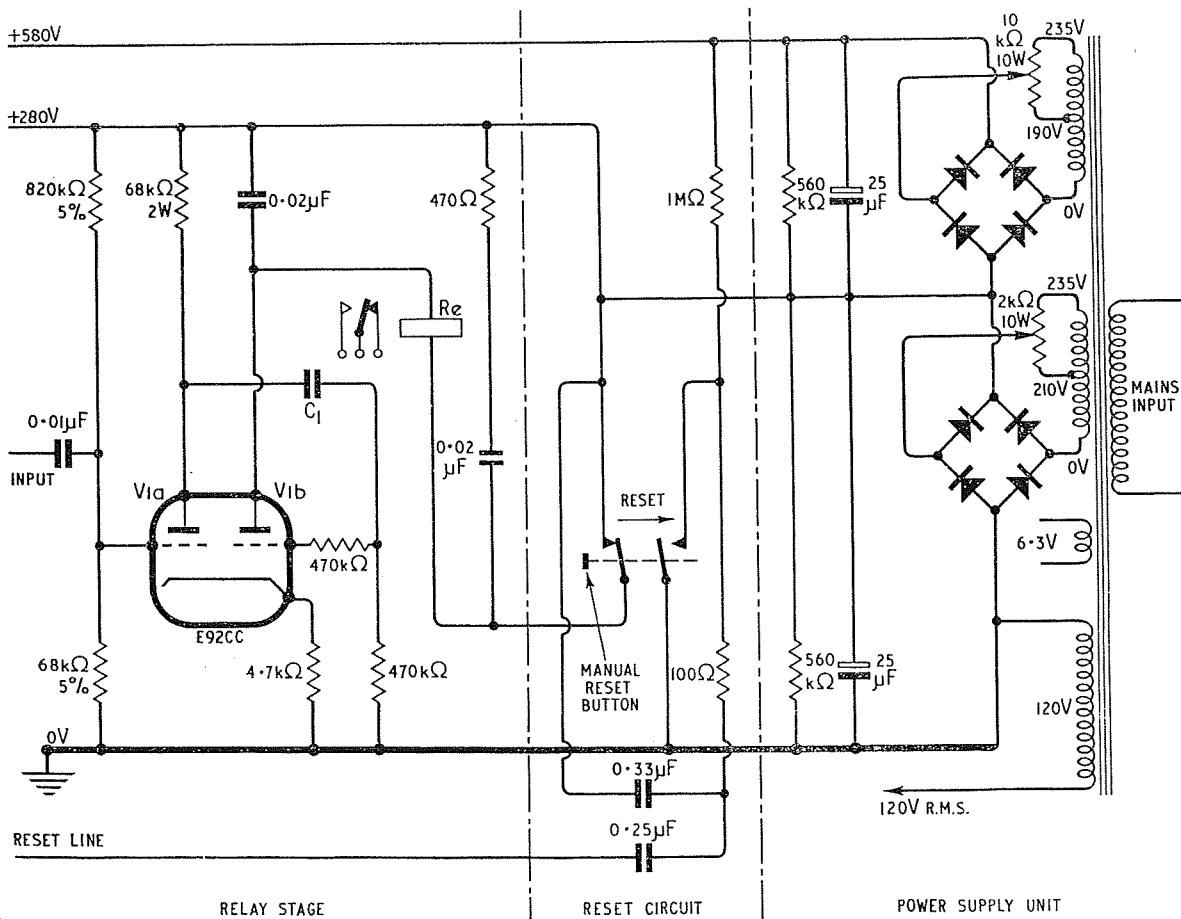

Fig. 4.62 A power supply, reset circuit and relay output stage for use with EZ10B circuits

ELECTRONIC COUNTING CIRCUITS

placed in each batch. The EZ10B tubes should be preset so that the counter indicates the difference between the maximum capacity of the scaler and the number of objects to be placed in each batch. The output pulse produced by the multivibrator or relay may be used to preset the counter and also to operate the mechanism which moves the con-

The transistor circuits discussed in this section operate satisfactorily in the temperature range 0°C to 45°C .

100 kc/s Transistor Input Circuit⁽³⁰⁾

A 100 kc/s counting stage employing a transistor blocking oscillator circuit to feed an EZ10B is

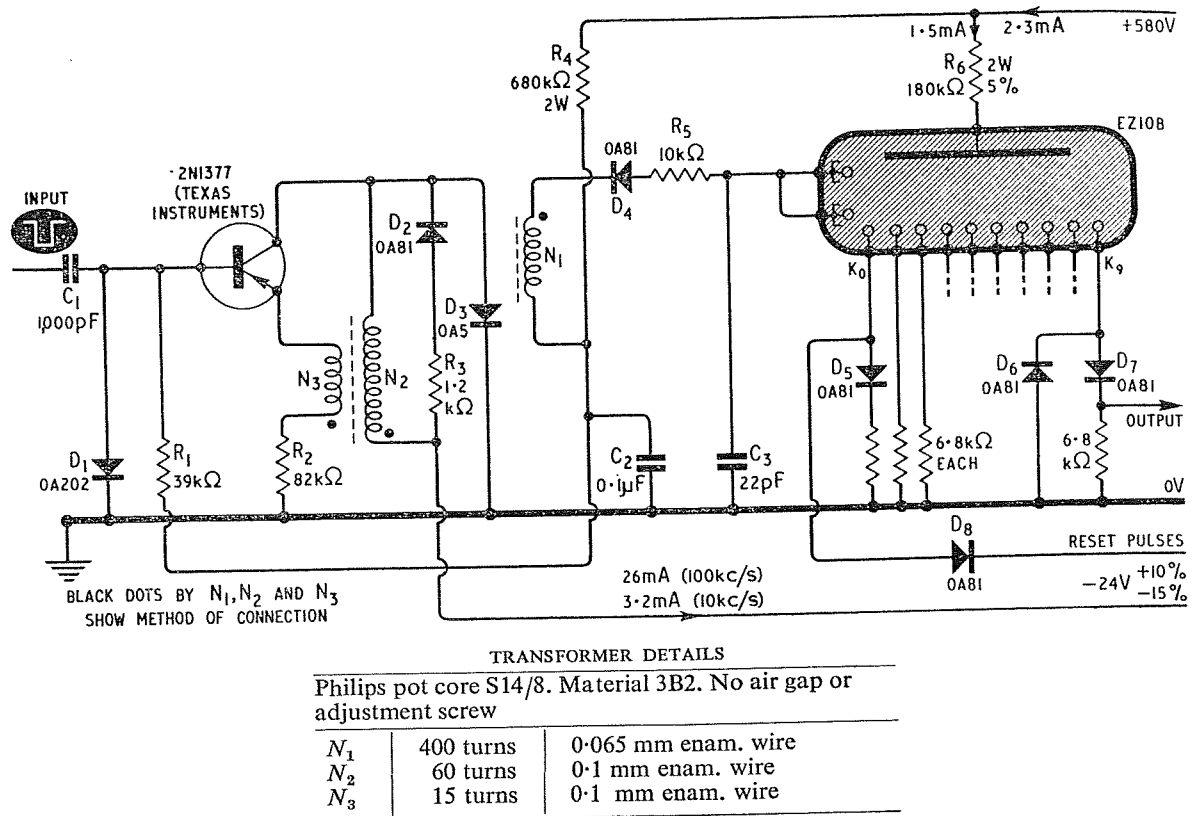

Fig. 4.63 A transistor drive circuit for the operation of the EZ10B at up to 100 kc/s

tainer for the next batch of objects into the correct position.

Transistor Circuits for the EZ10B

The EZ10B tube requires input pulses exceeding 100 V in amplitude for reliable operation. It has been found that the most economical way of producing such pulses is by the use of low priced transistors in blocking oscillator circuits. One transistor is required to drive each EZ10B tube. The quiescent power consumption is very small.

shown in Fig. 4.63. This circuit is normally used as the input stage of an EZ10B transistor scaler. The input pulses used to operate the circuit should have an amplitude of -10 V and a minimum duration of $3\ \mu\text{sec}$. The rise time of the negative going leading edge of the input pulse should be less than $1\ \mu\text{sec}$.

The three windings of the blocking oscillator transformer, N_1, N_2 and N_3 are wound on a common Philips S14/8 pot core. D_1 and D_3 protect the transistor base and collector respectively against any

MULTI-ELECTRODE GAS FILLED TUBES AND THEIR CIRCUITS

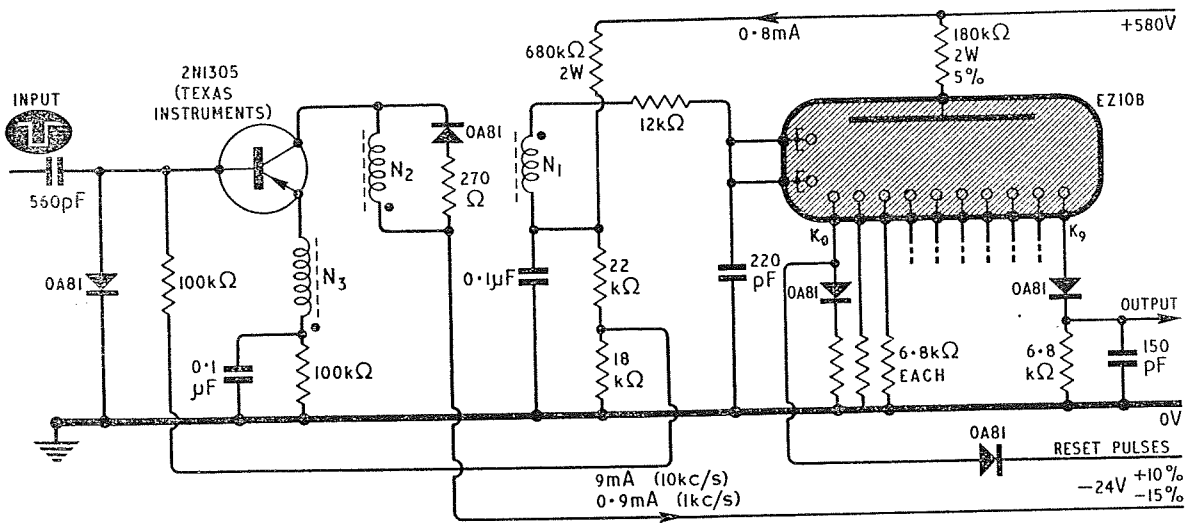

TRANSFORMER DETAILS

Philips pot core S18/12. Material 3B2. Air gap 0.16 mm
No adjustment screw

N_1	1200 turns	0.064 mm enam. wire
N_2	200 turns	0.1 mm enam. wire
N_3	70 turns	0.1 mm enam. wire

Fig. 4.64 A transistor drive circuit for the operation of the EZ10B at up to 10 kc/s

excessive peak voltages, whilst D_2 and R_3 (assisted by D_4) clamp the free oscillations of the transformer at the end of each pulse. R_5 and C_3 are used to give the pulse the desired shape. The output from the ninth cathode of the EZ10B may be used to feed a succeeding 10 kc/s stage.

The resetting pulses are applied through D_8 to the zero cathode. All of the zero cathodes are connected together by the reset line and diodes (such as D_8) provide the necessary decoupling. D_5 presents a high impedance to the reset pulses and prevents a large portion of these pulses from being shorted to earth.

10 kc/s Transistor Input Circuit⁽³⁰⁾

The circuit shown in Fig. 4.64 may be employed in scalars operating at input frequencies not exceeding 10 kc/s and in decades following the 100 kc/s circuit of Fig. 4.63. The 10 kc/s stage closely resembles the 100 kc/s stage, but the problem of damping the transformer oscillations is reduced because of the smaller mark to space ratio. The sensitivity of the circuit of Fig. 4.64 has been increased by placing a capacitor in parallel with the resistor in the emitter

circuit so that the stage can be operated from the output pulses furnished by the preceding decades.

Windings N_1 , N_2 and N_3 are all on a common core.

Pulse Shaping Circuit⁽³⁰⁾

The circuits of Figs. 4.63 and 4.64 require input signals with steep sides. The input circuit of Fig. 4.65 may be used to convert the incoming pulses

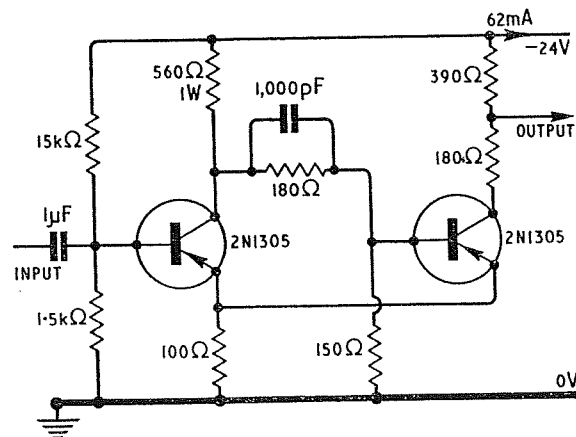

Fig. 4.65 A pulse shaping circuits for feeding the circuits of Figs. 4.60 and 4.61

ELECTRONIC COUNTING CIRCUITS

which are to be counted into pulses of a suitable shape for operating the counting stages. This pulse shaping circuit is basically a Schmitt trigger circuit which converts input signals of 5 to 15 V in amplitude and of arbitrary waveform into the 14 V rectangular pulses required for the operation of either of the counting circuits discussed previously.

The capacitor in the input of the pulse shaping circuit limits the lowest operating frequency for reliable counting of sine waves to about 5 to 10 c/s. At lower frequencies the capacitor may be omitted.

Relay or Magnetic Counter Operation⁽³⁰⁾

The circuit of Fig. 4.66 shows how a transistor amplifier may be used to convert the output pulses from an EZ10B tube into pulses which are suitable for the operation of a relay or an electro-magnetic counter.

When the discharge leaves the ninth cathode of the EZ10B, the resulting negative pulse is used to trigger a transistor monostable multivibrator which shapes the pulse. The resulting pulse is fed into an OC26 power transistor which operates the relay or

magnetic counter. The coil of the relay or counter should be designed to operate from 24 V at a maximum current of 0.5 A. The Sodeco magnetic counter type TCeZ6E which has a 24 V 350 Ω coil is suitable for use in this circuit.

Transistor Circuits Providing a Digital Display⁽³⁰⁾

The circuit of Fig. 4.67 shows how a digital display may be obtained from an EZ10B circuit by means of relatively cheap germanium PNP transistors. The cathode resistors have been divided into two sections so that a suitable output can be obtained for feeding into the bases of the transistors. Normally the emitters of the transistors are positive with respect to their bases; the transistors are therefore in their low resistance state and their collectors are almost at zero potential. When a certain cathode in the EZ10B strikes, however, a positive voltage is fed to the base of the corresponding transistor and this results in the transistor being cut off. The collector, therefore, becomes negative and this negative pulse causes the corresponding digit of the indicator tube to glow.

Table 4.9 THE BASIC DATA AND CONNECTIONS FOR THE ELESTA EZ10B TUBE

	<i>Min.</i>	<i>Normal</i>	<i>Max.</i>
Striking voltage	300	380	450
Maintaining voltage	280	300	330
Supply voltage	500	580	—
Anode current (mA)	1.2	1.5	1.9
Anode resistor (Ω)	—	180 k	—
Slope of pulse sides (V/sec)	—	—	10^9
Input pulse duration and spacing (sec)	5×10^{-7}	—	—
Input pulse amplitude (V)	SEE TEXT		
Resetting pulse amplitude (V)	—	120	—
Cathode resistor (Ω)	0	6.8 k	6.8 k
Peak output amplitude (V)	—	7	—
<i>Dimensions</i>			
Seated height 48 mm max.	Diameter 21 mm max.		
<i>Escutcheon</i>			
Elesta type ZB33 with circular polarised filter to improve contrast.			
<i>Base</i>			
13 pin miniature fitting into 15 pin Elesta socket ZB13.			
<i>Connections</i>			
1 K_0	2 K_9	3 K_8	4 K_7
5 K_6	6 K_5	7 K_4	8 K_3
9 K_2	10 K_1	11 and 13 transfer electrodes	15 A

When the wires have been soldered to the tube socket, the pins of the socket should remain completely movable to prevent strains at the glass base which could cause small cracks around the base pins.

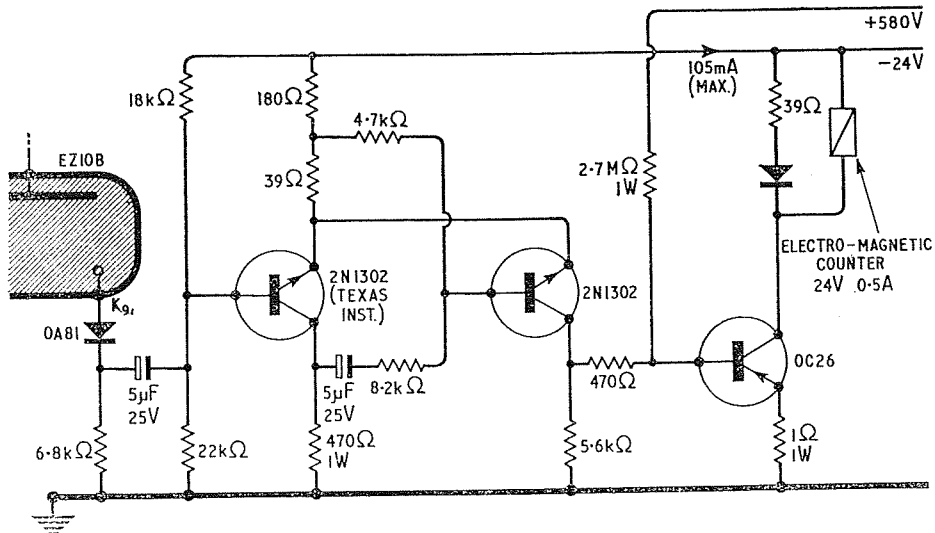

4.66 A transistor circuit for coupling the EZ10B to an electro-magnetic counter

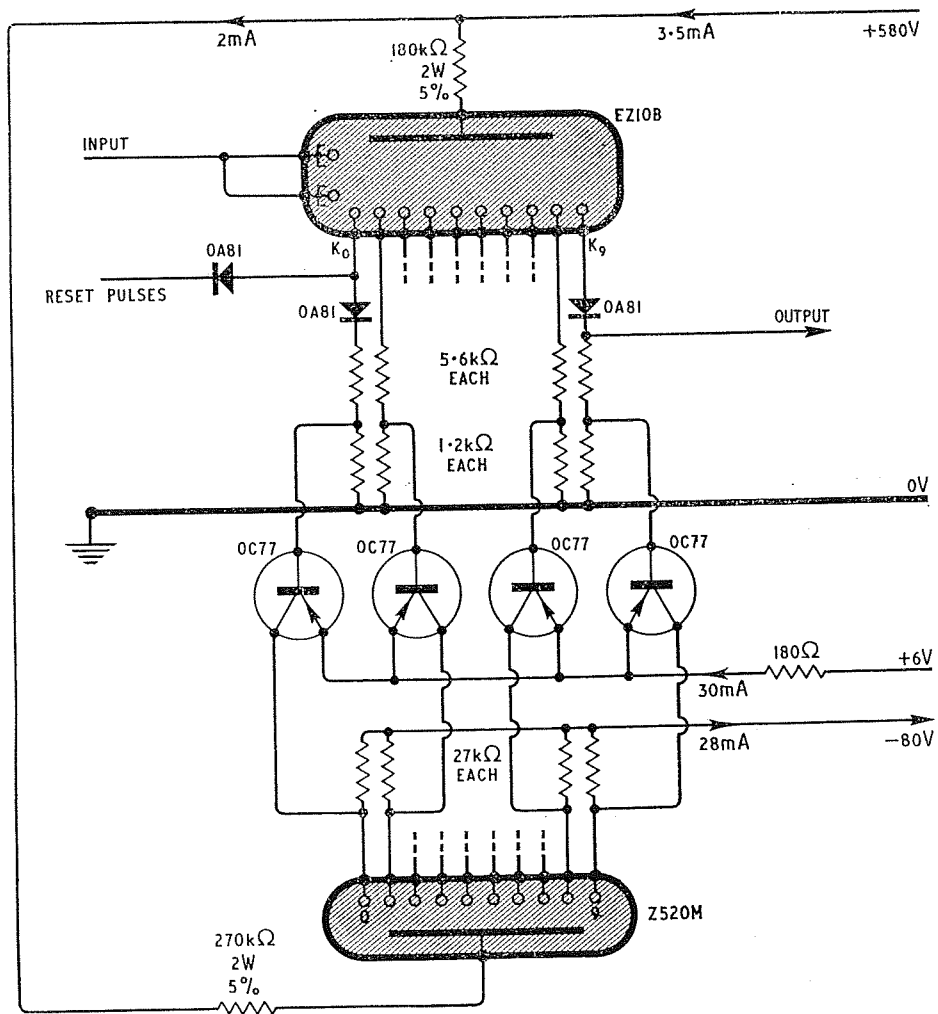

Fig. 4.67 Digital display from an EZ10B tube using PNP transistors

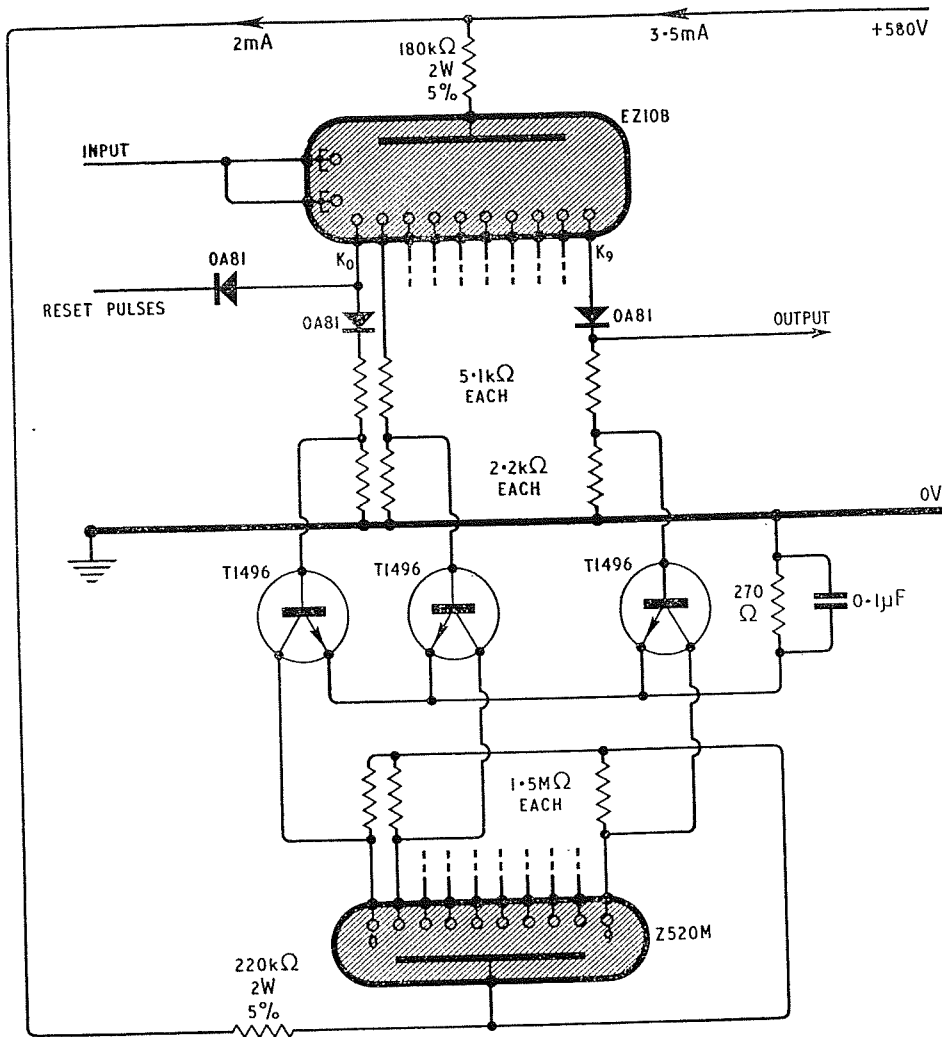

Fig. 4.68 Digital display from an EZ10B tube using NPN transistors

The disadvantage of this type of circuit is that nine of the ten transistors are conducting at any one time and, therefore, the current consumption is fairly high.

The circuit of Fig. 4.68 employs NPN Texas Instrument transistors type TI496 (or an equivalent type). The use of NPN transistors enables the positive voltage from the circuit of the EZ10B glowing cathode to be used to switch the corresponding transistor to the conducting state. Thus only one of the ten transistors is conducting at any instant and the power consumption is considerably smaller than when the circuit of Fig. 4.67 is used.

4.8.3 The ECT100 Reversible Selector Tube

The Elesta ECT100 tube⁽³⁵⁾ operates on principles which are rather different from those of the other tubes which have been discussed in this chapter. The electrode assembly and the basic circuit for the ECT100 tube is shown in Fig. 4.69. Four star shaped electrodes are stacked inside a cylindrical anode, *A*, so that they are separated from each other by a very small distance. Two of the electrodes are main cathodes and two are guide cathodes. Each of the four electrodes has five limbs or spokes, each of which points to the anode. The limbs are in

the same plane as the remainder of the particular electrode ring to which they are attached. An output electrode, S , is placed at the end of each main cathode limb. The fifteen electrodes of the system are placed in a miniature glass envelope which is filled with hydrogen.

One of the cathode rings will be referred to as K_1 and the other as K_2 . The first limb of the K_1 ring will be called K_{11} and the second limb of this ring K_{12} , etc. Similarly the fourth limb of K_2 will be designated K_{24} . A similar nomenclature will be used

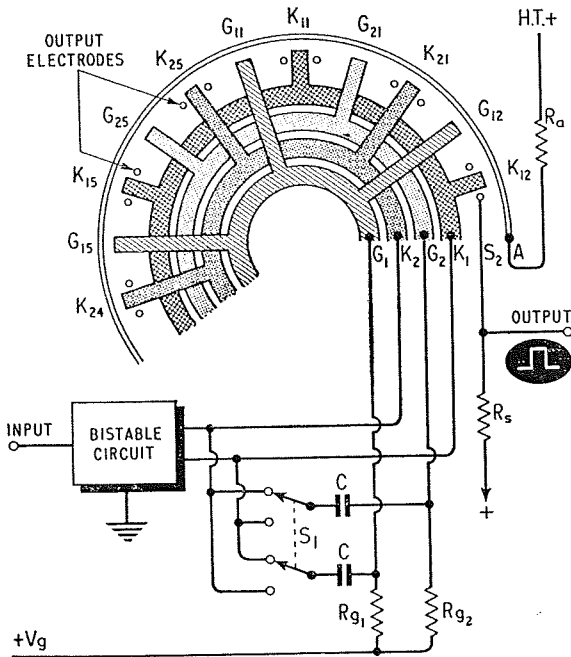

Fig. 4.69 The structure of the ECT100 tube and the basic circuit in which it is used

for the two guides (G_1 and G_2) and for the guide limbs.

The cathode rings are fed from the two outputs of a bistable circuit as shown in Fig. 4.69. The outputs of the bistable circuit are also differentiated and applied to the guides. The switch S_1 reverses the direction of counting; when G_1 is connected via a capacitor to K_1 , the tube counts in a forward or clockwise direction.

When the tube first strikes, a discharge occurs between the anode and one of the limbs of the cathode ring which is at the lower potential. Let us

assume that an initial discharge takes place at K_{11} . The potential drop across the tube anode resistor ensures that the tube cannot strike at any other limb of the same cathode ring. The other electrodes (K_2 , G_1 , G_2 and the ten output electrodes) are all at a positive potential with respect to K_1 and no discharge can occur between the anode and any one of them.

An input pulse will change the state of the bistable circuit and the potential of K_1 rises as that of K_2 falls. In addition the guide electrodes receive pulses of opposite phase. If the switch S_1 is in the position shown in Fig. 4.69, the potential of G_2 falls and the discharge moves to G_{21} , since this is the most strongly primed limb of G_2 . The positive going pulse applied to G_{11} prevents any possibility of the discharge moving in the wrong direction. As the amplitude of the differentiated pulse applied to G_2 decays, K_2 becomes the most negative of the electrodes. The discharge therefore moves to the limb of K_2 which is most strongly primed, namely K_{21} . A second input pulse will return the multivibrator to its initial state and the discharge will move to G_{12} and then to K_{12} .

If the position of the switch S_1 is changed and an input pulse is applied when the discharge is resting at K_{11} , G_1 will receive a negative going pulse. The discharge therefore moves in an anticlockwise direction from K_{11} to G_{11} and then to K_{25} . Thus the tube is counting in reverse.

In order to obtain the maximum possible reliability, the output waveforms from the multivibrator should be symmetrical with respect to each other. The guide bias should be equal to half the mean amplitude of the multivibrator output. The quiescent guide potential is slightly above the guide bias supply voltage, since a small 'probe' current always flows through the guide resistors when the discharge is resting at a main cathode. The rise time of the multivibrator output pulses should be short so that the peak voltage of the differentiated drive pulses equals the cathode drive pulse amplitude. Stray electrode capacitance must, of course, be kept low if a high counting speed is required. The time constant of the differentiating components must be short compared with the time taken for one count to be registered.

ELECTRONIC COUNTING CIRCUITS

Readout and Reset

The tube provides the normal visual readout (which is blue in colour) and in addition electrical readout can be obtained by the use of the output electrodes.

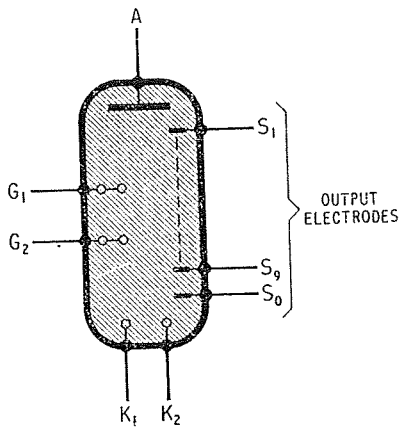

Fig. 4.70 The symbol for the ECT100 tube

Each main cathode has a small output electrode associated with it and the latter acts as a probe in the discharge. A positive going output pulse is obtained whose amplitude is a function of the output electrode load resistance. The output electrodes receive a positive bias to prevent them from initiating a discharge.

If outputs are not required from all of the output electrodes, a number of these electrodes may be connected together and returned to the output electrode bias supply via a common load resistor of maximum value $1\text{ M}\Omega$. At frequencies not exceeding 100 kc/s any number of the output electrodes may be connected in parallel.

If a large negative going pulse is applied to an output electrode, the discharge is transferred to this electrode for the duration of the pulse and the voltage drop across the tube anode resistor causes the discharge at any other point in the tube to be extinguished. At the end of the resetting pulse the main cathode limb which is adjacent to the conducting output electrode takes over the discharge, since it is strongly primed. The bistable circuit must be reset at the same time as the ECT100 tube.

The symbol for the ECT100 tube is shown in Fig. 4.70; for simplicity only three of the ten output electrodes are included in the symbol.

100 kc/s ECT100 Stage

A transistor driven ECT100 decade stage⁽³⁵⁾ is shown in Fig. 4.71. The two transistors are employed in a non-saturating bistable circuit in order to render the circuit less dependent on the current gain of the transistors. The input pulses should be negative

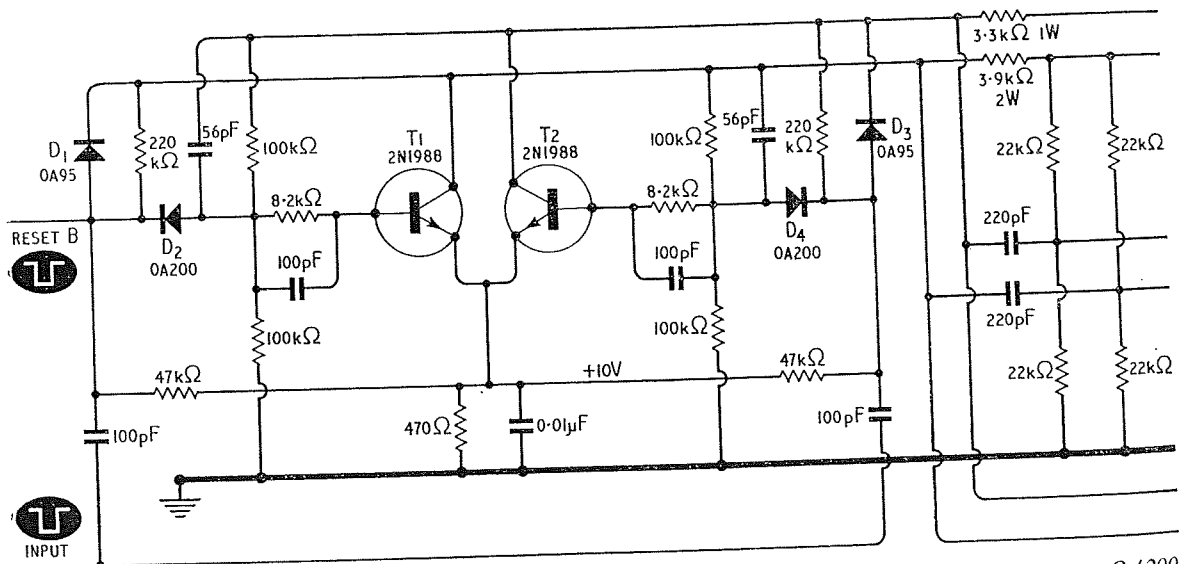

Fig. 4.71 A 100 kc/s circuit for the ECT100 tube. $D_1 = D_3 = 0A95$ or $AAZ10$; $D_2 = D_4 = 0A200$, $BFY13$ may be used instead of the

going, of between 10 and 25 V peak amplitude and of a duration which is not less than 0.1 μ sec. The negative going leading edge which triggers the bistable circuit should have a rise time not exceeding 4 μ sec. These pulses may be obtained from an identical preceding counter decade or from the pulse shaping circuit of Fig. 4.72. The method of feeding the ECT100 from the bistable circuit is similar to that of Fig. 4.69, except that no direction reversing switch is shown.

The ten output electrodes are returned via 100 k Ω resistors to a potential of +60 V on the potential dividing chain. For simplicity, only three output electrodes and three of their load resistors are shown in the circuit of Fig. 4.71. When the discharge moves to position nine (K_{25}), the positive going pulse at the ninth output electrode (S_9) renders D_5 conducting. The collector waveform is fed back through D_5 to S_9 when the discharge leaves position nine; this results in the output pulse to the next decade having the required sharp negative going edge and enables the delay between successive stages to be reduced to less than 0.4 μ sec.

Power supply voltage changes of +10% to -15% will not affect the operation of the circuit of Fig. 4.71. If unstabilised voltage supplies are employed,

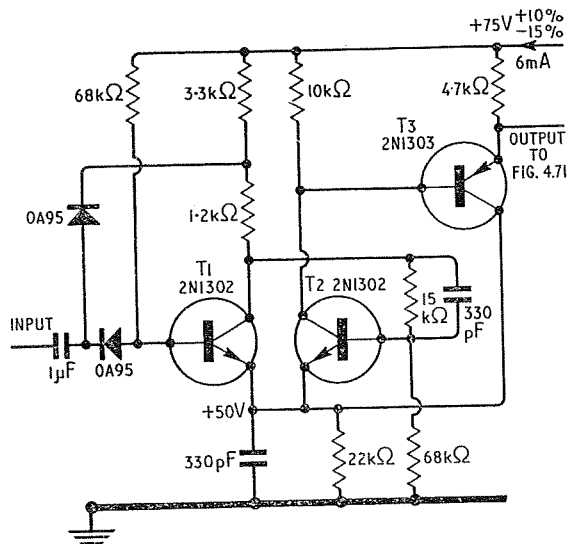

Fig. 4.72 An input pulse shaping unit

the effects of any mains voltage variations on the tube bias and drive circuits tend to cancel each other. If stabilisation is necessary, all of the voltage supplies should therefore be stabilised.

The input pulse shaping circuit of Fig. 4.72 is designed to provide the pulses with a sharp negative going edge which are required for the operation of the circuit of Fig. 4.71. The circuit shown in Fig. 4.72 consists of a Schmitt trigger circuit followed by an emitter follower circuit. It can be operated by input pulses of any shape which have a peak amplitude of not less than 18 V. The output pulses from the circuit of Fig. 4.72 have an amplitude of 13 V and a rise time of 0.2 μ sec when no load is applied to the output.

If a negative going pulse of 220 V in amplitude and not less than 10 μ sec in duration is applied at the 'Reset A' terminal of Fig. 4.71 and at the same instant a negative going pulse of at least 10 V in amplitude is applied to the 'Reset B' terminal, the circuit will be reset to zero. The pulse applied to the 'Reset A' terminal resets the tube and that which is applied to the 'Reset B' terminal resets the bistable circuit.

The circuit of Fig. 4.73 can be used for providing the pulses required for resetting any number of stages up to ten. When the resetting switch is closed, the capacitor C discharges and a negative pulse of about 220 V in amplitude is fed through the diodes

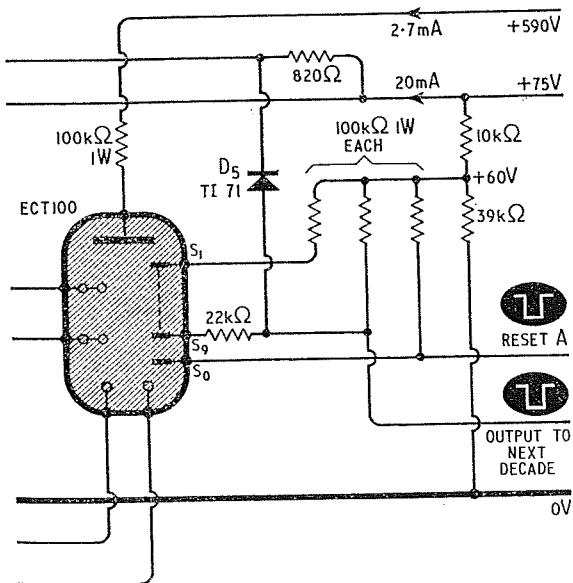

0A130 or 1S130; $D_5 = TI71$ (Siemens transistors type 2N1988 transistors specified)

ELECTRONIC COUNTING CIRCUITS

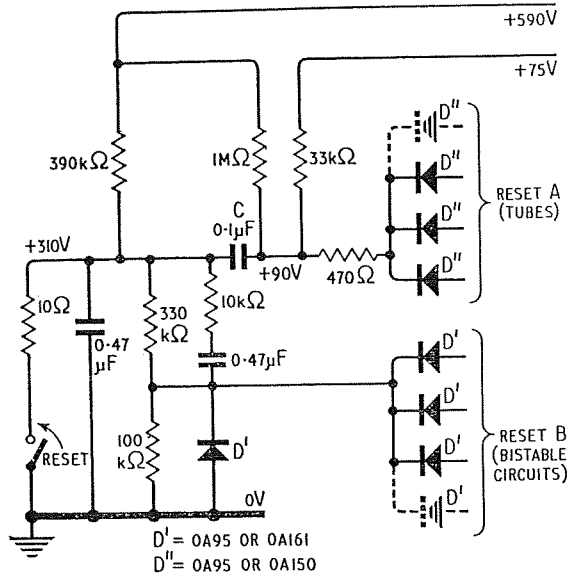

Fig. 4.73 A resetting circuit for the ECT100

D'' to reset the ECT100 tubes. The outputs from the circuit of Fig. 4.73 which are connected to the bistable circuits (Reset B) are normally at a potential of +72 V, but when the resetting switch is closed, this potential falls to zero. The circuit is capable of carrying out ten resetting operations per second. The supply voltage tolerances are -15% to $+10\%$ of the specified nominal value.

1 Mc/s ECT100 Decade

A 1 Mc/s circuit for the ECT100 is shown in Fig. 4.74⁽³⁶⁾. The output pulses from this circuit may be used to directly drive the 100 kc/s circuit of Fig. 4.71. The reset pulses required for the 1 Mc/s decade are similar to those required for the 100 kc/s decades. Four ES11 voltage stabiliser tubes are used in the anode circuit of the 1 Mc/s decade. The 25 kΩ resistor in the anode circuit of the ECT100 tube in Fig. 4.74 should be adjusted until the potential difference across the 33 kΩ anode resistor is 52 V. The absolute maximum speed at which the ECT100 can count is about 2 Mc/s.

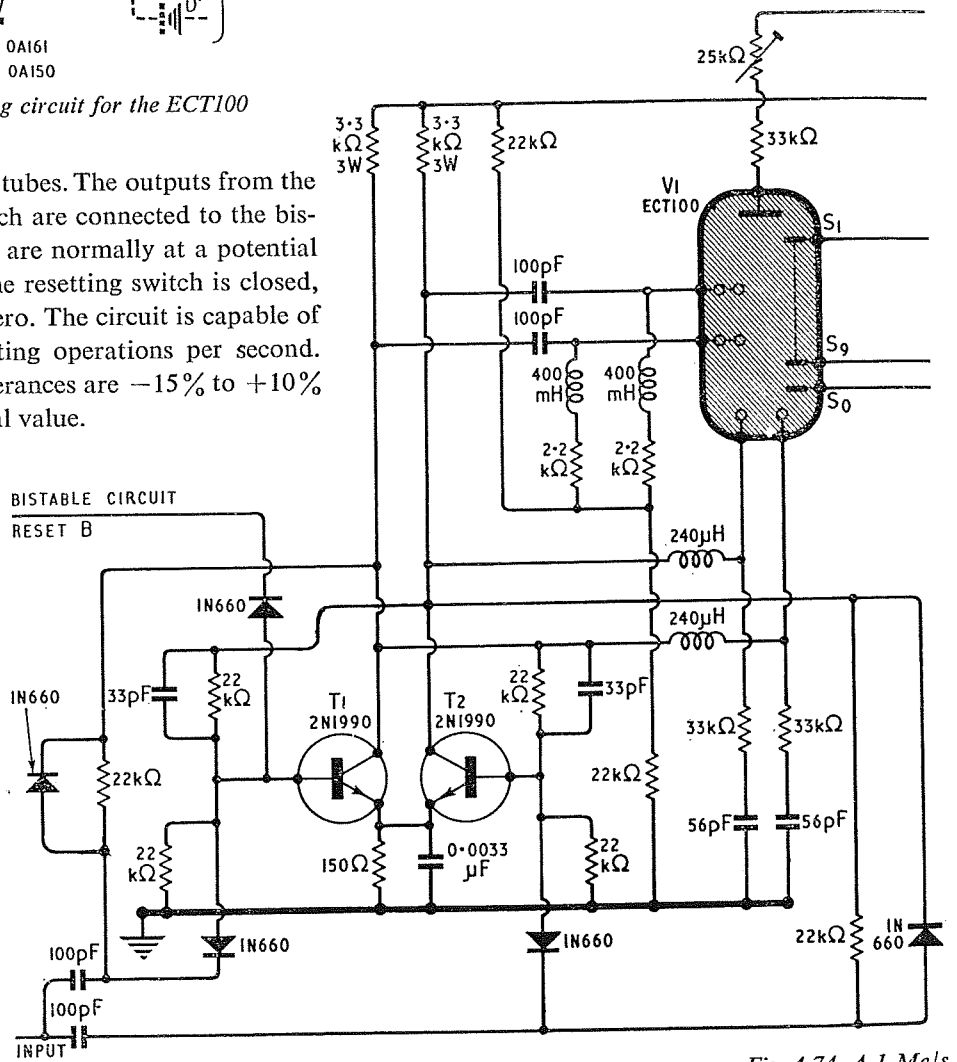
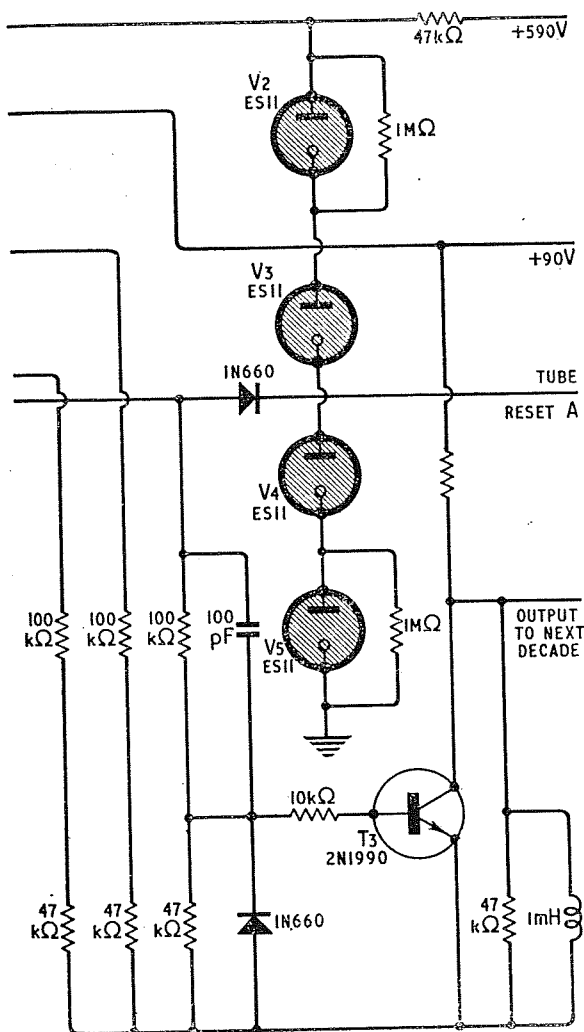

Fig. 4.74 A 1 Mc/s

MULTI-ELECTRODE GAS FILLED TUBES AND THEIR CIRCUITS

Table 4.10 BASIC DATA AND BASE CONNECTIONS FOR THE ECT100 TUBE

Anode to cathode breakdown voltage	320-375	Base	Connections
Maintaining voltage	295-320	1	S ₀
Temperature range	-100 to +100 °C	2	S ₉
Max. magnetic field (gauss)	200 (any direction).	3	S ₈
Mounting position	Any	4	S ₇
Minimum life (h)	25,000	5	S ₆
		6	S ₅
		7	S ₄
Dimensions		8	S ₃
Seated height 38 mm (max.)	Diameter 21 mm (max.)	9	S ₂
		10	S ₁
Escutcheon		11	A
Elesta type ZB23 with circular polarised filter		12	K ₂
		13	G ₂
Base		14	K ₁
Elesta special type socket ZB25		15	G ₁



circuit for the ECT100

4.9 MULTIPLE ANODE COUNTING TUBES

The characteristics of the multiple cathode tubes described in the preceding sections of this chapter tend to change if the discharge rests for a long time at any one cathode. The sputtering which occurs at the cathodes results in a non-uniformity of the cathode surfaces and a reduction in reliability. New types of tube are being developed in England⁽³⁷⁾ and Japan⁽³⁸⁾ in which the reliability is improved by the use of a single cathode surrounded by a number of anodes. If the cathode is a wire completely surrounded by the glow, no variation of the tube characteristics due to changes in the cathode surface are likely to occur during the life of the tube. Some multiple anode tubes employ a circular cathode resembling the anode of a normal double pulse tube; in this case only a part of the cathode surface is covered by the glow at any one time.

Multiple anode tubes have the additional advantage that they can drive numerical indicator tubes directly without any intermediate amplifying device. Each anode of the counting tube is connected to the appropriate cathode of the indicator tube.

4.9.1 Inverse Tubes

One type of multiple anode tube consists of a single cathode surrounded by thirty anodes. The structure is very similar to that of the conventional double pulse tube, but the polarity of the applied potential

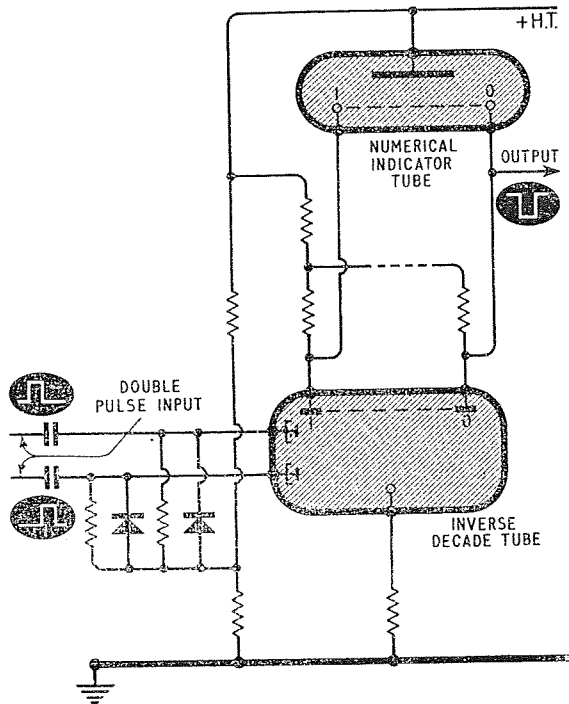

Fig. 4.75 The basic circuit for the operation of an inverse tube

is reversed. Such tubes are often referred to as inverse tubes, although the Japanese tubes are known as 'Polyatrons'. The operation is very similar to that of normal double pulse tubes. Ten of the anodes are main anodes, whilst the other twenty are used as first and second guide electrodes. The tube registers a count when a suitable positive going pulse is applied to the first guides followed by a positive going pulse to the second guides. The amplitude of the guide pulses is smaller than for the conventional double pulse tubes, about 40–50 V⁽³⁷⁾.

The basic circuit for the operation of an inverse decade tube is shown in Fig. 4.75. The load resistor may be placed in the indicator tube anode circuit or in the counting tube cathode circuit. The method of applying pulses to the guides is the same as that used with normal double pulse tubes, but the pulses must be positive going.

4.9.2 Magnetically Biased Tubes⁽³⁷⁾

Another type of multiple anode tube employs twenty anodes, one guide anode being placed be-

tween each two main anodes. In this type of tube the direction of rotation of the glow is determined by the polarity of an applied magnetic field. If the guide electrodes are left unconnected, a value of the magnetic field strength can be found at which the discharge will rotate continuously. A suitable negative potential applied to a guide will cause the rotation to cease. In this type of tube the guides may, therefore, be referred to as locking electrodes.

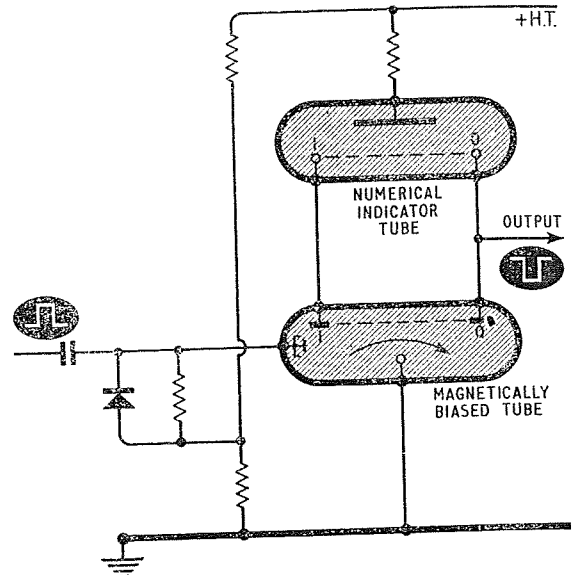

Fig. 4.76 The basic circuit for a magnetically biased decade tube

It is possible to operate tubes of this type by applying a pulse to all of the guides simultaneously so that the discharge commences to rotate, but the duration of the pulse must be controlled if only one count per pulse is to be registered. Pulses of 20 V in amplitude are sufficient. They may have any shape, since once the discharge has commenced to rotate, the stepping process is independent of the locking electrode potential. Alternatively alternate locking electrodes may be connected together and the two groups (each of five electrodes) thus formed may be driven from the two outputs of a bistable circuit; this effectively prevents the tube from stepping more than one position if the input pulses are long.

The speed of operation of the present experimental magnetically biased tubes is limited to a few

hundred cycles per second, but the characteristics are very stable. An external magnet is employed, but the field uniformity and alignment are not critical. The basic circuit for the operation of a numerical indicator tube from a magnetically biased decade tube is shown in Fig. 4.76.

It seems certain that more will be heard of multiple anode gas filled decade tubes in the future, since they seem likely to satisfy the increasing demand for a very high degree of reliability coupled, of course, with an economical form of digital readout.

REFERENCES

1. J. J. LAMB & J. A. BUSTMAN, 'A polycathode glow discharge tube for counters and calculators', *Electronics*, **22**, 92 (1949).
2. 'Dekatrons Containing Neon', Ericsson Telephones Tube Division, (1962)
3. R. C. BACON & J. R. POLLARD, 'The Dekatron', *Electron. Eng.*, **22**, 173 (1950).
4. G. F. JEYNES, 'Decade stepping tubes and their operation', *Mullard Technical Communications*, **4**, 37, 194 (1959).
5. 'Decade Counter Tube Handbook', Sylvania Special Tube Dept, Publication ET-3911-13MZ-11/13 (1964).
6. G. F. JEYNES & S. ZILKHA, 'Trigger tube coupling circuits for counting tubes', *Mullard Technical Communications*, **7**, 66, 184 (1963).
7. G. F. JEYNES & S. ZILKHA, 'Cold-Cathode Trigger-Tube Coupling Circuits for the Z504S Stepping Tube', Mullard Report no. A.R.L. 594.
8. G. F. JEYNES & S. ZILKHA, 'Power Supply and Manual Reset Circuits for the Z504S Scaler described in A.R.L. 594' (An addendum to the previous reference).
9. G. C. CHAPPELL & G. F. JEYNES, 'Transistorised Coupling Circuits for the Z504S Stepping Tube', Mullard Report no. A.R.L. 612; G.C. CHAPPELL & G.F. JEYNES, 'Transistor coupling circuits for the Z504S stepping tube', *Mullard Technical Communications*, **7**, 70, 310 (1964); 'A Decade Scaler', Mullard Educational Service (1964); C.S. BARKER & G.F. JEYNES, 'Counting circuit design using the inherent reliability of counting tubes', *Brit. I.R.E. Symposium, Cambridge* (1964); C.S. BARKER, 'Operating principles of the Z504S stepping tube', *Mullard Technical Communications*, **8**, 75, 131 (1965).
10. 'Mullard Cold Cathode Tubes'. I.E.A. Exhibition, May 1962.
11. 'Decade Counting Circuit with In-line Numerical Readout', Mullard Publication no. TP528. (May 1963); R.D. RYAN, 'A 50 kc/s cold-cathode decade counter' *Electronic Eng.*, **36**, 779, (1964); 'Devices for Industrial Counting', Mullard Ltd., R.E.C.M.F. Exhibition (May 1965).
12. D. G. M. DAWE, 'A 100 c/s counter for registering small time intervals', *Electron. Eng.*, **33**, 582 (Sept. 1961).
13. Ericsson Tube Technical Handbook, Ericsson Telephones Ltd.
14. H. SADOWSKI & M. E. CASSIDY, 'How transistor drives cold-cathode counter', *Electronics*, **32**, 46 (1959).
15. H. A. KAMPF, 'Increasing counting system reliability', *Electronics*, **32**, 112 (1959).
16. E. K. ASCHMONEIT, 'Die Dekatronröhren, gasgefüllte Zählröhren mit symmetrischen Kathoden', *Elektronik*, **5**, 301 (1956).
17. L. C. BRANSON, 'Reversible Dekatron counters', *Electron. Eng.*, **27**, 266 (1955).
18. D. REANEY, 'A new Dekatron for the direct operation of digitrons'. *Electron. Eng.*, **34**, 372, (1962).
19. N. MCLOUGHLIN, D. REANEY & A. W. TURNER, 'The digitron'. *Electron. Eng.*, **32**, 140 (1960).
20. 'Digitron Display Tubes', Ericsson Tube Division (1962).
21. G. HIGGINS, 'A gas-filled glow discharge character display tube', *J. Brit. I.R.E.*, **22**, 2, 133 (1961).
22. 'Transistor Operation of Digitron Tubes', Ericsson Tube Division Publication P. 6105.1.
23. Ericsson Circuit LK 226.
24. J. R. ACTON, 'The single pulse Dekatron', *Electron. Eng.*, **24**, 48 (1952).
25. Sodeco Information Sheet E 48.
26. 'Operation of Decade Counter Tubes', Raytheon Publication SP1097 (1963).
27. Cerberus sheets 2.13.10D.
28. 'G10/241E Nomotron', S.T.C. Valve Division Application Report No. MS/114.
29. 'The Decade Counter Tube EZ10B', Elesta Technical Communications, No. 17, (Feb. 1961).
30. 'Die Zählröhre EZ10B in Transistorschaltungen'. Elesta Technische Mitteilungen Nr. 18 (April 1962).
31. K. APEL & P. BERWEGER, 'Miniature gas-filled tubes for high speed counting'. *Electronics*, **33**, 46 (1960).
32. Elesta Technische Mitteilungen, Nr. 14 (Jan. 1960).
33. H. L. v. GUGELBERG, 'Eine neue dekadische Zählröhre mit kalten Kathoden', *Helv. Phys. Acta*, **26**, 586 (1953).
34. K. APEL, Elektronische Zähl-schaltungen, Franckh'sche Verlagshandlung, Stuttgart (1961).
35. 'Decade Counter Tube ECT100', Elesta Sheets 24. 12. O1E (May 1963); 'ECT100-A New Decade Counting Tube', Elesta Technical Communications, No. 20 (July 1963).
36. '1 Mc/s ECT100 Counter Module', Elesta publication (Oct. 1963).
37. D. REANEY, 'The multiple anode Dekatron', *Brit. I.R.E. Symposium on Cold Cathode Tubes, Cambridge* (March 1964).
38. Y. HATTA, H. MASE & M. SUGAWARA, 'A new poly-anode counting tube, the "Polyatron"', *J. Brit. I.R.E.* **26**, 5, 383 (1963).

EIT Decade Counting Circuits

The principle of operation of the Mullard/Philips EIT decade counter tube is fundamentally different from that of all other types of counting tube. The EIT is a high vacuum tube which has been especially designed for counting purposes; it has an indirectly heated cathode. The EIT is basically a small cathode ray tube of special design without any vertical deflecting plates and of about the same size as an octal based radio receiving tube. It has the advantage of being a self indicating device, but it cannot easily be used to control digital indicator tubes because the same electrodes are always being employed in the EIT whatever the state of the count. The method of readout is unique. An H.T. supply of 300 V is adequate for most EIT circuits.

The EIT is not a gas filled device and, therefore, its maximum operating speed is not limited by

ionisation and deionisation times. All EIT tubes can operate at counting speeds up to at least 30,000 pulses per second, but about 75% of all the tubes can be used in slightly more complicated circuits for counting at frequencies up to 100,000 pulses per second⁽¹⁾. Operation at frequencies of the order of one million pulses per second has been reported⁽²⁾.

The form and the dimensions of the EIT are shown in Fig. 5.1.

5.1 READOUT

The EIT tube employs a ribbon shaped electron beam of rectangular cross section which has ten stable positions in the tube. A small portion of the beam passes through one of the ten holes in the anode and strikes a fluorescent coating on the inside of the tube envelope so that a vertical green luminescent mark is formed in a position near to the digit which is to be indicated. The ten digits themselves are marked on a paper mask which is fixed to the outside of the tube. The beam advances at one step per input pulse until the digit 'nine' is reached, after which a further input pulse will reset the beam to zero.

Even digits are indicated as a mark on the upper strip of fluorescent material and odd digits on the lower strip (see Fig. 5.1); this enables a clearer indication to be obtained than would be possible if only one fluorescent strip were used to indicate all ten digits. The beam itself is not deflected vertically in order to enable it to strike the appropriate fluorescent strip, but is merely deflected horizontally across the tube. There are holes placed alternately in the upper and lower parts of the anode; when the beam

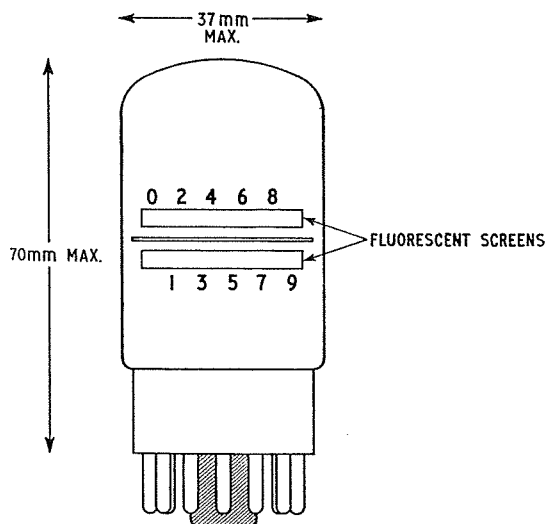

Fig. 5.1 The EIT decade counting tube

passes through one of the upper holes an even digit is indicated, but at the next step it will pass through one of the lower holes to indicate an odd digit. Only a small portion of the beam passes through a hole, the remainder of the beam being intercepted by the anode.

5.1.1 The Electrodes of the EIT

In order to show that the tube has ten stable positions, the somewhat complicated electrode structure of the tube (shown in cross section in Fig. 5.2) must be studied. The conventional symbol for the tube, as used in circuits, is shown in Fig. 5.3 with the connections to the B12A base. Some of the less

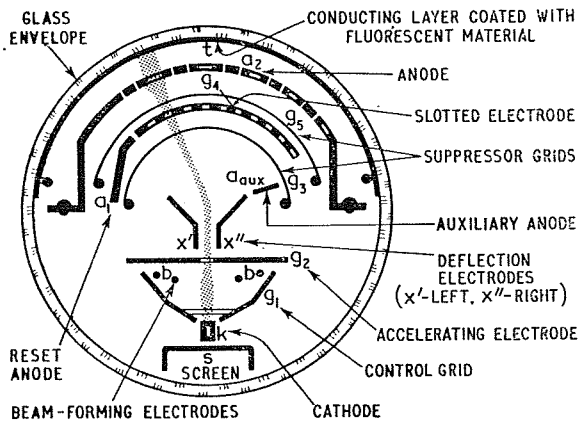
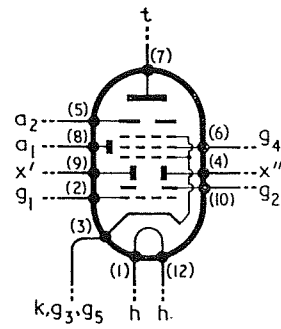

Fig. 5.2 The electrode structure of the EIT

important electrodes which have no external connection are not shown in this symbol. Sometimes g_3 and g_5 are also omitted from the symbol.

The electron beam is formed at the rectangular shaped cathode, k , the front of which is covered with an electron emissive oxide coating. The beam flows through the control grid, g_1 , past the beam forming electrodes, b , and is then accelerated through the electrode g_2 . These electrodes focus the beam and also give it the desired rectangular cross section which resembles a piece of thick ribbon placed in a vertical plane.

The beam is then deflected by the deflector plates, x' and x'' , into one of the ten stable positions. The electrodes g_3 and g_5 are suppressor grids which are internally connected to the cathode to prevent any



BASE SOCKET:—DUODECAL TYPE 5912/20

Fig. 5.3 The symbol for the EIT; the numbers indicate the base connections

unwanted effects which might be caused by secondary electron emission from g_4 or from the anode, a_2 .

The electrode g_4 has slots of the shape shown in Fig. 5.4. As will be shown later, it can be arranged that the electron beam will be stable only when a certain fraction of it is passing through one of the vertical rectangular slots in g_4 . The purpose of the horizontal slot will be discussed later.

The beam then travels to the anode, a_2 . A portion of it passes through the anode to the fluorescent target, t . This target is covered with a conductive coating which is connected to the positive H.T. supply line so as to prevent the accumulation of negative charge from the electron beam which might disturb the operation of the tube.

The electrode a_1 is the reset anode. When the tube is indicating the digit 'nine' and a further pulse is received, the beam is deflected by the plates x' and x'' so that it strikes the reset anode; the mecha-

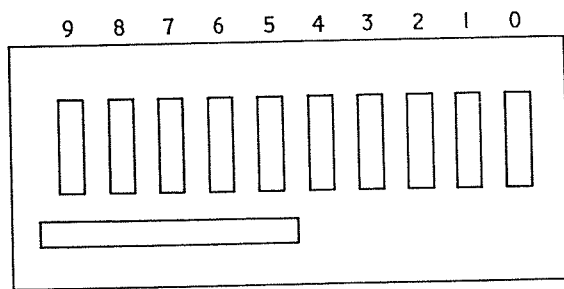

Fig. 5.4 The g_4 electrode showing the one horizontal and ten vertical slots

ELECTRONIC COUNTING CIRCUITS

nism by which the tube is reset is then initiated by the fall of the reset anode potential.

The auxiliary anode, a_{aux} , is internally connected to the accelerating electrode, g_2 , and is employed to capture undesired stray electrons. The screen s is internally connected to the cathode.

5.1.2 Ribbon Shaped Electron Beams^(3, 4)

In tubes such as the EIT in which the beam is deflected only in one plane, a ribbon shaped electron beam of relatively large cross sectional area can be used (since the resolution in one plane is unimportant), but in normal cathode ray tubes a very small circular beam must be used to obtain good resolution in two dimensions. For a given charge density in the beam and a given applied voltage, a larger current will flow in a ribbon shaped beam than in a small circular beam owing to the larger cross sectional area of the former. A large current is desirable in the EIT so that the stray electrode capacitances can be quickly charged. The ribbon shaped beam enables the tube to operate from fairly small voltages. This favours high operating speeds because the change in the electrode potentials (and hence the change in the charge of the stray capacitances) is kept small.

The use of a ribbon shaped beam also has the additional advantages that the dimensions of the tube (and hence the inter-electrode capacitances) can be small and that the alignment of the tube need be carried out accurately only in one dimension.

In the EIT a beam current of about 1 mA is used at an applied potential of about 300 V.

5.2 ANODE CHARACTERISTICS

The anode characteristics of the EIT must be examined in order to ascertain why the ten holes in g_4 enable the electron beam to exist in ten stable states. If the horizontal slot in g_4 (shown in Fig. 5.4) were not present, the main anode current, i_{a_2} , plotted against the deflector voltage of plate x'' ($V_{x''}$) would be as shown in Fig. 5.5(a) provided that the potential of the other deflector plate, $V_{x'}$, were kept constant. When the potential of x'' is altered, the beam is deflected and passes through a series of

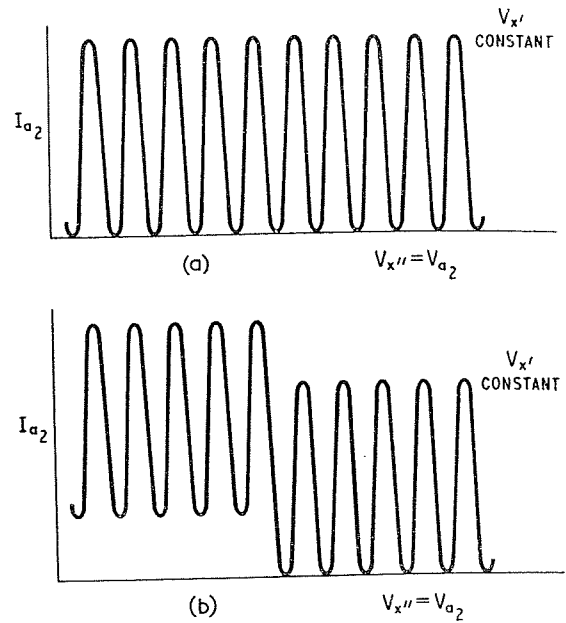

Fig. 5.5 Theoretical characteristics of the EIT, (a) when g_4 has no horizontal slot and (b) when the horizontal slot is present in g_4

maxima and minima as it passes across the holes in g_4 . The anode current will be a maximum when the beam is centred on one of the holes in g_4 and will be zero when it is entirely intercepted by g_4 .

In normal operation the main anode, a_2 , is connected directly to the deflector plate x'' . The potentials of x'' and of a_2 are therefore identical and Fig.

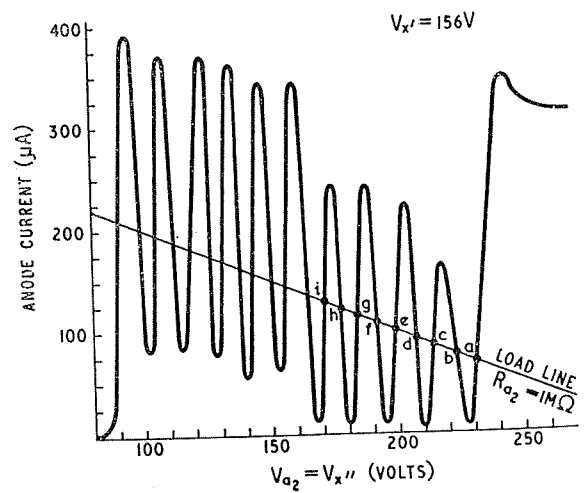

Fig. 5.6 The EIT anode characteristic for $V_{x'} = 156$ volts

5.5(a) is the dynamic anode current/anode voltage characteristic for this method of connection when the potential of x' is constant.

The presence of the horizontal slot in Fig. 5.4 changes the anode characteristic from that shown in Fig. 5.5(a) to that shown in Fig. 5.5(b). When the beam is in a position to the left of the fifth vertical slot in Fig. 5.4, a constant current passes through the horizontal slot and this current is superimposed on any current which may pass through one of the vertical slots. Hence the shape of the Fig. 5.5(b) characteristic.

In practice the characteristic is further modified by the fact that the slots in g_4 are not of constant width. The actual EIT anode characteristic is shown in Fig. 5.6 for the case when the x' deflector electrode has a potential of 156 V (1, 5, 6). It may be noted that when both of the deflector electrodes have the same potential ($V_{x'} = V_{x''} = V_{a_2} = 156$ V), the beam is not deflected and the tube indicates a number in about the middle of the decade.

5.3 BEAM STABILITY

The basic type of circuit used to supply voltages to the tube is shown in Fig. 5.7. The anode resistor, R_{a_2} , normally has a value of 1 M Ω . The straight line in Fig. 5.6 is the load line for this value of resistor.

If the beam is initially at the position a of Fig. 5.6 (indicating the digit zero) and the potential of the deflector electrode x' is increased relatively slowly (so slowly that the effect of the stray capacitance, C , shown in Fig. 5.7 is negligible), the beam will tend to be deflected towards the electrode x' . As the beam moves, however, it can be seen from the anode characteristic of Fig. 5.6 that it begins to pass out of the slot in g_4 and less of it strikes the anode. The resulting reduction in anode current leads to a reduction in the voltage dropped across the resistor R_{a_2} and hence to an increase in the common potential of the anode and of the deflector electrode x'' . The slope of the EIT characteristic is very steep at the points where it is crossed by the load line shown and therefore this increase in the potential of x'' is almost equal to the initial increase in the potential of x' which caused it. As both deflector electrodes

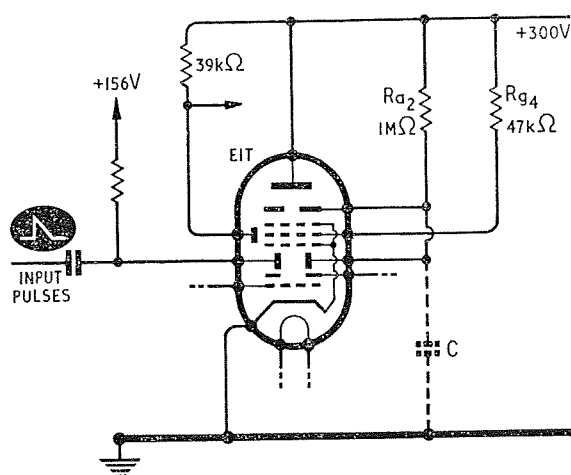

Fig. 5.7 The basic circuit for the EIT

are increased in potential by almost equal amounts, the amount by which the beam is deflected is virtually unchanged.

Similarly if the beam is at a and x' becomes slowly more negative, the anode current is increased (see Fig. 5.6) and this in turn causes a reduction in the potential of x'' . Thus the position a in Fig. 5.6 is a very stable one. The intersections of the load line with the rising parts of the EIT characteristic are the ten stable beam positions which are required for storing the information about the state of the count.

The anode a_2 and the x'' deflector plate are connected in a feedback system. The slope of the EIT characteristic is very much greater than the slope of the 1 M Ω load line at the operating point and this results in the feedback factor — and hence the stability of the operating point — being very high. The positions a, c, e, g, i , etc. in Fig. 5.6 are all very stable.

If the beam is at any moment at b or d , any slight increase in the potential of x' will cause the beam to be deflected towards this electrode and it can be seen from Fig. 5.6 that the anode current will then increase as more of the beam passes through the slot in g_4 . The potential of the anode and of x'' therefore decreases causing the beam to swing farther away from the x'' electrode. Eventually the beam will come to rest at one of the stable points c or e . Similarly if the beam is momentarily at b or d and the potential of x' is decreased slightly, the beam

will move so that the voltage of x'' becomes higher until a stable operating point is reached. The positions b, d, f , etc. are therefore unstable and the beam does not stay in a position represented by one of these points for more than a minute fraction of a second. At these unstable points the anode current decreases with increasing anode voltage, thus giving

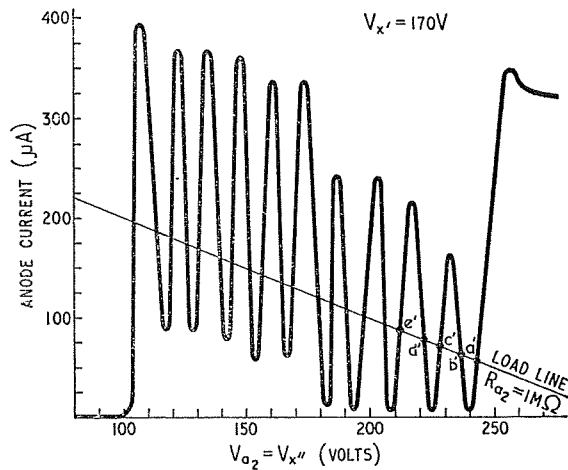

Fig. 5.8 The EIT anode characteristic for $V_{x'} = 170$ volts

a negative resistance effect over this portion of the curve.

The criterion of stability for any operating point in Fig. 5.6 is that the anode current of the EIT must increase as the anode voltage increases. That is, the point at which the load line cuts the characteristic of the tube is stable if the characteristic at that point slopes upwards from left to right.

If for any reason (such as a change in the supply voltage) the potential of x' alters fairly slowly, the anode current/anode voltage characteristic will maintain the same general form as shown in Fig. 5.6, but will be moved horizontally along the x axis (anode voltage axis) of the graph. This is because the stabilising effect discussed above alters the voltage of the anode and x'' electrodes to maintain the beam deflection almost constant.

Fig. 5.8 shows the anode characteristic for an EIT with a potential of 170 V applied to the x' deflector electrode^(1, 5, 6). It can be seen that the same system of stable and unstable operating points will be present and the general operation of the tube is unaffected by this voltage change.

5.4 THE COUNTING PROCESS

A very different process occurs when a positive going pulse with a very short rise time is fed to the x' electrode. The beam will be deflected to the left and the potential of the anode and x'' electrode will again tend to rise by the process discussed previously. The capacitance C (shown dotted in Fig. 5.7) prevents any very rapid change in the potential of the anode and of the electrode x'' , as time is taken for C to charge through R_{a2} . The capacitance C is merely the inter-electrode and stray wiring capacitance of the tube circuit. The beam is therefore deflected to the left before the voltage of x'' has time to rise appreciably. If the pulse is rapid enough and of a suitable amplitude, the beam will therefore move to the next stable position to the left of the initial position in Fig. 5.6 and a count will have been registered.

The stabilising mechanism of the tube circuit cannot work more quickly than is permitted by the anode resistance R_{a2} and the unavoidable stray parallel capacitance, C .

The pulse rise time and amplitude are quite critical. If the pulse is of too small an amplitude, the beam will not be deflected as far as the next stable position and no count will be registered, whilst if the amplitude is too large, the beam may pass through one stable position and register two counts for only one input to x' . The amplitude of the input pulse should be approximately equal to the difference of the tube anode voltage between two adjacent working points, e.g. a and c in Fig. 5.6. The geometry of the tube and the shape of the electrodes are carefully chosen so that the voltage difference between each of the stable working points (a to c , c to e , etc. in Fig. 5.6) is constant (about 13.6 V). The input voltage required to cause the tube to register one additional count is therefore independent of the digit being indicated.

It is most important that the input pulse amplitude to the x' plate of the tube should be $13.6 \text{ V} \pm 15\%$ (that is, 11.5 to 15.5 V).

An additional requirement is that the trailing edge of the pulse must not be too sharp or it will deflect the electron beam back to its initial state and no count will be registered. If the slope of the trail-

ing edge is not very great, the stabilising effect discussed previously will prevent the tube returning to its initial state when the trailing edge is applied to x' . If the time of fall of the pulse is too long, however, the maximum counting speed is reduced. It might be thought that if the stray capacitance, C , could be made very small, the maximum counting rate could be increased. In actual practice, however, the reset time is usually longer than the counting process itself and sets a limit to the maximum counting speed.

A suitable pulse for feeding into the x' electrode of the EIT is shown in Fig. 5.9. The slope of the leading edge of the pulse should not be less than 2×10^7 V/sec and that of the trailing edge should not be greater than 1.2×10^6 V/sec. If the average amplitude of the pulse is to be 13.6 V, the rise time should not therefore be greater than $0.7 \mu\text{sec}$ and the time of fall should not be less than $11 \mu\text{sec}$.

The mechanism of the counting process can be considered to operate in the following way. If the operating point is at a in Fig. 5.6 corresponding to

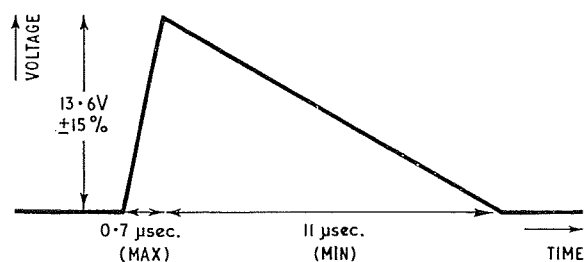

Fig. 5.9 An input pulse suitable for the operation of the EIT

an indication of zero, the anode and x'' potential is about 230 V whilst the x' deflector electrode potential is about 156 V. If a fast rising positive going pulse of 14 V is applied to the x' electrode (raising its potential to 170 V), the voltage of the x'' electrode remains constant for a very small fraction of a second owing to the stabilising effect of the capacitance C . The operating point is therefore momentarily moved to the point c' on the characteristic of Fig. 5.8. The pulse then decays slowly so that the potentials of x' and x'' decrease at about the same rate. Thus the operating point on the characteristic of Fig. 5.8 at c' is transformed relatively slowly into the characteristic of Fig. 5.6, but the operating point

now has time to move along with the curve and finishes at c in Fig. 5.6.

It can be seen from Fig. 5.6 that the horizontal slot in g_4 (see Fig. 5.4) lifts up the low voltage part of the anode current/anode voltage characteristic so that the height of each peak above the load line is fairly constant. The rate at which the stray capacitance, C , can be discharged by the EIT anode current during counting operations is dependent on the height of each peak of the characteristic above the load line. A reasonable height for each peak is essential in high speed counting circuits. This subject is more fully discussed in the section of this chapter which deals with the design of an input circuit for 100 kc/s operation.

The stabilising effect of C on the anode potential should not be confused with the stabilising effect that R_{a_2} has on the position of the beam. Advantage is taken of the latter effect (which is suppressed during the steep front of the input pulse by the presence of C) for maintaining the beam at the correct position after it has been displaced.

5.5 FLYBACK CIRCUITS

When the tenth input pulse is received, the EIT tube must be reset from 'nine' to 'zero'. Normally this resetting process is initiated by a pulse from the reset anode, a_1 , which is connected to the H.T. positive line via a 39 k Ω resistor (as in Fig. 5.7). If the tube is initially indicating the digit 'nine' and an additional input pulse is received, the beam will be deflected to strike the reset anode. The current passing to this anode will cause a voltage drop across the 39 k Ω resistor and a negative pulse can therefore be obtained from the reset anode. The pulse may be used to trigger a monostable multivibrator which is designed to provide suitable pulses to reset the tube and also to trigger the next decade.

Another method of obtaining a pulse to reset the EIT circuit does not depend on the use of a reset anode. When the beam is deflected from position 'nine' onto the reset anode, it leaves the g_4 electrode. This electrode is fed from the H.T. line via the resistor R_{g_4} and its potential therefore rises as the current through the resistor falls. This rise in potential can be used to render a triode conducting and the triode

in turn provides a pulse to cut off the EIT. An example of this type of circuit will be given in Fig. 5.16.

The EIT itself may be reset by two basic methods. In the first method a negative pulse is applied to the control grid, g_1 , or a positive pulse to the cathode, k . This pulse should have an amplitude of at least 24 V so that it is large enough to completely cut off the electron beam. The main anode current falls and therefore the main anode and x'' electrode potential rises. The change of the x'' electrode potential causes the beam to be deflected towards it so that 'zero' is indicated. This method of resetting the tube takes a comparatively long time and cannot therefore be used in high speed circuits. The circuitry required is, however, simpler than that used in the higher speed resetting circuits. Examples of practical circuits involving beam cut off will be given in the circuits of Figs. 5.10, 5.13 and 5.16.

In the second method of resetting the tube, a positive pulse is applied to the x' electrode and deflects the beam to the zero position. This method is suitable for high speed circuits operating at up to one million pulses per second⁽²⁾. An example of this type of circuit will be given in Fig. 5.15.

5.5.1 Reset Involving Beam Cut Off

When an EIT tube is cut off, its anode voltage will rise exponentially as the stray capacitance C (shown dotted in Fig. 5.7) charges through the resistor R_{a_2} . The time taken for this capacitance to charge limits the maximum frequency of operation of the tube. The minimum reset time may be estimated by the method discussed below.

It is important to ensure that the duration of the cut off pulse fed to the tube is great enough (with an adequate safety margin) to allow the stray capacitance, C , to charge to a potential which is enough to cause the beam to return at least as far as the zero position. Otherwise the beam may come to rest at any intermediate position. If the cut off time is too long, however, the reset time will be increased and the maximum counting rate will be reduced. If the beam is deflected too far, it will be in an unstable state and will quickly return to the zero position at the end of the cut off pulse.

It can be estimated from Fig. 5.6 (allowing adequate safety margins for normal tolerances, etc.) that the maximum voltage swing of the anode a_2 ever likely to occur in practice is from $V_{a_2}(9) = 95$ V in position 'nine' to $V_{a_2}(0) = 240$ V at the 'zero' position⁽¹⁾. The maximum stray capacitance, C , in parallel with R_{a_2} can be taken as 16.5 pF. If a close tolerance 1% high stability resistor is used for R_{a_2} , the maximum possible value of this resistor will be 1.01 M Ω . In addition a 10 k Ω resistor is normally placed in series with R_{a_2} for test purposes (as shown in Figs. 5.13 and 5.15). The maximum value of R_{a_2} is therefore 1.02 M Ω .

The capacitance C charges from the H.T. supply voltage V_b from the initial anode voltage of $V_{a_2}(9)$ volts to $V_{a_2}(0)$ volts during the cut off pulse.

It is shown in many elementary text books on electricity that if a capacitor C is charged from a source of voltage V_b via a resistor R , the voltage V across the capacitor after a time t is given by the relation:

$$V = V_b(1 - e^{-t/RC})$$

where e is the base of natural logarithms.

The above equation may be altered to:

$$\frac{V_b - V}{V_b} = e^{-t/RC}$$

This equation applies only if $V = 0$ when $t = 0$. In the case of the stray capacitance C charging through the resistor R_{a_2} , however, $V = V_{a_2}(9)$ initially.

If C had charged to a potential of $V_{a_2}(9)$ from an initial potential of zero through R_{a_2} , the time taken, t_1 , would be given by:

$$\frac{V_b - V_{a_2}(9)}{V_b} = e^{-t_1/R_{a_2}C} \quad (1)$$

If t_2 is the total time taken for the potential across the capacitance C to reach the value $V_{a_2}(0)$ from an initial value of zero,

$$\frac{V_b - V_{a_2}(0)}{V_b} = e^{-t_2/R_{a_2}C} \quad (2)$$

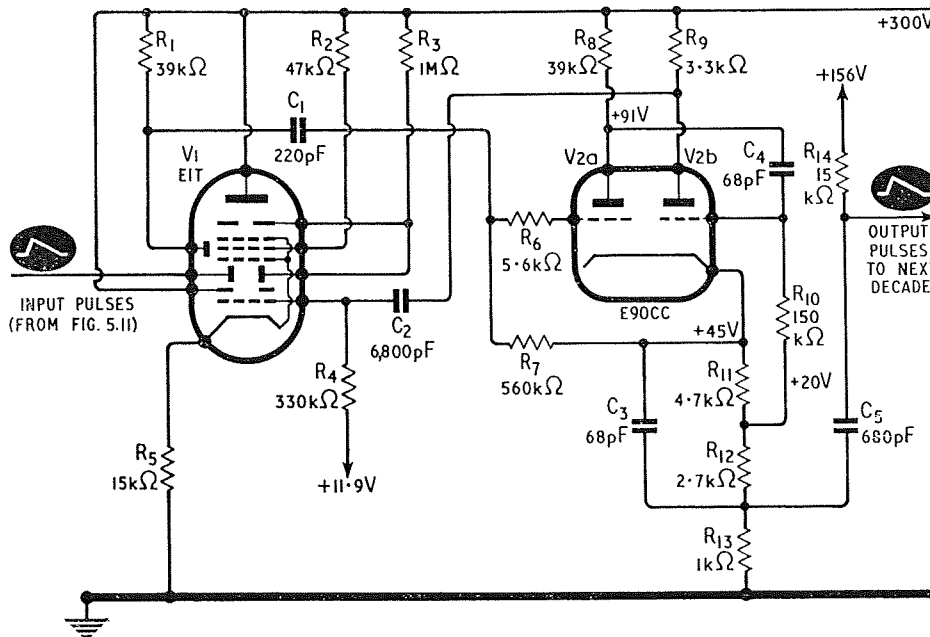

Fig. 5.10 An EIT counting and reset circuit for operation at frequencies of up to 30 kc/s

Dividing (2) by (1):

$$\frac{V_b - V_{a_2}(0)}{V_b - V_{a_2}(9)} = e^{-(t_2 - t_1)/R_{a_2}C}$$

In this equation $(t_2 - t_1)$ is equal to the time taken for the beam to move from position 'nine' to the 'zero' position.

Let $(t_2 - t_1) = T$

$$\frac{V_b - V_{a_2}(0)}{V_b - V_{a_2}(9)} = e^{-T/R_{a_2}C}$$

Putting the values quoted above into this equation:-

$$\frac{300 - 240}{300 - 95} = e^{\left(\frac{-T}{1.02 \times 10^6 \times 16.5 \times 10^{-12}}\right)}$$

When this equation is solved for T , it is found to be about 20.68 μ sec. This is the minimum possible resetting time. In actual practice the resetting pulse should be somewhat longer than this in order to allow an adequate margin of safety. If an allowance of 33 μ sec is made for the resetting time, the maximum counting rate which can be attained is about 30,000 per second⁽¹⁾.

It is found in actual practice that EIT circuits can operate reliably at up to 30,000 pulses per second

when the resetting operation is carried out by cutting off the electron beam in the tube in the type of circuit shown in Fig. 5.10. In practical circuits the stray capacitance C should be kept as low as possible. The anode resistor R_{a_2} should be soldered directly to the a_2 or x'' contact of the EIT tube base.

5.6 30 KC/S COUPLING CIRCUIT

A circuit^(1, 5, 6) which will reset EIT tubes and provide a suitable pulse for triggering the next tube is shown in Fig. 5.10. The E90CC (V_2) acts as a monostable multivibrator. The grid of V_2a is returned to the cathode of this valve via R_7 , and no bias is provided. V_2a is therefore normally fully conducting when the circuit is in the stable state. The anode current of V_2a flowing through the 4.7 k Ω cathode resistor (R_{11}) produces a voltage drop of about 25 V across this resistor. The grid of V_2b is returned to the lower end of this resistor and the 25 V across it therefore biases V_2b to cut off.

If the electron beam is deflected onto the reset anode, a current flows through the reset anode resistor (R_1) of the EIT and the negative voltage pulse produced is applied to the grid of V_2a via the

capacitor C_1 . The anode current of $V2a$ is thereby reduced so that a positive pulse is produced at its anode. This pulse is fed to the grid of $V2b$ via C_4 and causes this triode to conduct. A positive pulse is generated at the cathode of $V2b$ and the common cathode voltage increases, thus cutting off $V2a$. The grid voltage of $V2b$ is therefore raised further.

The negative pulse from the anode of $V2b$ is fed to the grid g_1 of the E1T via the capacitor C_2 . The E1T is thus cut off and therefore the main anode and x'' electrode of this tube rises in potential so that the beam is deflected to the zero position. The rise in total cathode current of $V2$ when $V2b$ conducts is used to trigger the succeeding decade via C_5 .

As C_4 discharges at the end of the pulse, the grid potential of $V2b$ decreases exponentially. The common cathode voltage also decreases exponentially until the bias is reduced so much that $V2a$ conducts. The resulting negative pulse at the anode of $V2a$ passes to the grid of $V2b$ via C_4 and quickly restores the circuit to its original stable state in which $V2a$ is conducting and $V2b$ is cut off.

If C_3 were omitted, a pulse with a steep leading edge could not be obtained from the cathode resistor of $V2$ for the purpose of triggering the next decade unless the value of R_8 were reduced. A lower value of R_8 would, however, result in a much greater continuous current being taken from the H.T. supply. If C_3 is used to shunt most of the cathode resistor, as shown, only the $1,000\ \Omega$ resistor is operative for abrupt changes of voltage and sharply rising output pulses can be obtained. The high value of the cathode resistor together with the fairly large value of R_8 render the circuit very stable. The pulse amplitude and duration are not affected very much by changes in the valve characteristics. The tapping on the cathode resistor at the junction of R_{12} and R_{13} has been chosen so that the output pulse to the next decade is of a suitable amplitude.

The negative going pulse which is used to cut off the E1T commences by a rapid fall of potential of about 60 V. The potential then rises to about $-27\ \text{V}$ in a period of about $27\ \mu\text{sec}$. The tube is completely cut off by a bias of $-27\ \text{V}$ and the duration is very suitable for ensuring that the beam is reset to zero without the reset time being much longer than is necessary.

The component tolerances for the coupling circuit of Fig. 5.10 are shown beneath Fig. 5.13.

5.7 INPUT CIRCUIT FOR FREQUENCIES UP TO 30 KC/S

An input circuit must be employed in front of the first E1T tube. This circuit converts the incoming pulses into pulses of an amplitude and duration which can be counted by the E1T. The input circuit described in this section (shown in Fig. 5.11.) is suitable for handling up to 30,000 pulses per second.

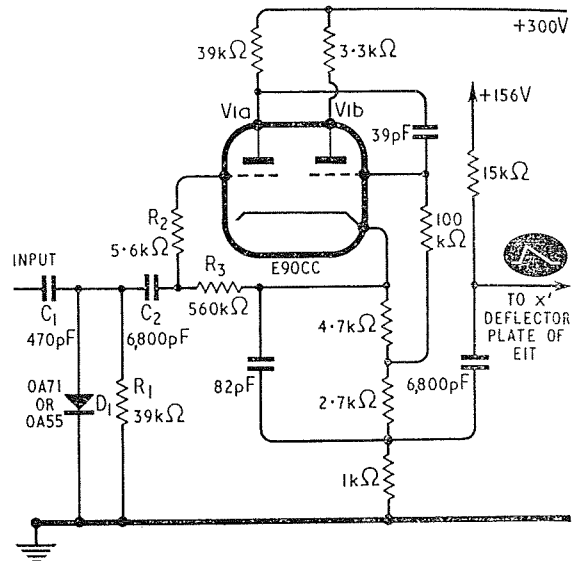

Fig. 5.11 An input pulse shaper circuit for use at frequencies of up to 30 kc/s

A faster but more complicated input circuit will be discussed later.

The input circuit ^(1, 5, 6) of Fig. 5.11 consists of a differentiating circuit ($470\ \text{pF}$ plus $39\ \text{k}\Omega$) followed by a monostable multivibrator which is very similar to that used in the resetting circuit of Fig. 5.10.

If the differentiating circuit were omitted, at a low rate of counting the length of the input pulses might exceed that of the natural period of the multivibrator. The multivibrator would then return to its initial state whilst the input pulse was still present and a spurious count would be registered. This difficulty is only encountered in the input circuit and not in the circuits of succeeding stages because the

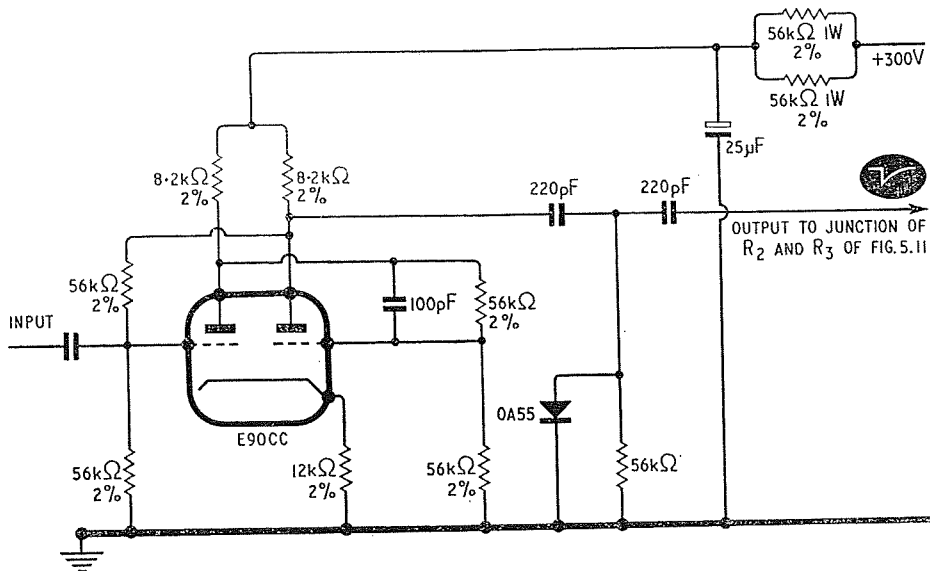

Fig. 5.12 An auxiliary pulse shaping circuit for feeding the circuit of Fig. 5.11 or 5.13

inputs to all stages after the first are derived from the multivibrator of the previous stage which gives a pulse length which is quite short.

The 0A71 germanium diode in parallel with the 39 kΩ input resistor prevents any positive pulses from reaching the grid of $V1a$. Such pulses arise from the trailing edge of a negative going input pulse or the leading edge of any stray positive going pulse; if they reached the grid of $V1a$ they could cause faulty counting.

The coupling capacitor and the grid resistor of $V2b$ have somewhat lower values than those recommended for the coupling circuit of Fig. 5.10 in order that the maximum counting rate can be attained. The output pulses will be somewhat shorter owing to the lower time constant, but this is no disadvantage, however, since the pulses from the multivibrator of Fig. 5.11 do not have to operate a resetting circuit.

The triode $V1a$ is normally conducting and $V1b$ is normally cut off. The input pulses to $V1a$ should have an amplitude of between 20 and 50 V and should be negative going with a leading edge duration not exceeding 13.5 μsec or positive going with a trailing edge duration not exceeding this same value. The total pulse duration should equal one cycle of the pulse repetition frequency less at least 10 μsec. At 30,000 pulses per second this input

pulse duration should not therefore exceed $33.3 - 10 = 23.3$ μsec.

The component tolerances for the circuit of Fig. 5.11 are shown below that of Fig. 5.13.

If sinusoidal signals are to be counted, they may be passed through a double limiter which will clip both positive and negative going peaks. A square wave input signal is thus obtained which can be used to operate the circuit of Fig. 5.11.

5.7.1 Auxiliary Pulse Shaper

The circuit of Fig. 5.12 may be used to convert pulses of arbitrary waveform (including sine waves) into pulses which will operate the circuit of Fig. 5.11^(6,7). When this additional pulse shaping circuit is used, the components marked C_1 , C_2 , D_1 and R_1 in Fig. 5.11 may be omitted.

The use of the circuit of Fig. 5.12 enables sine waves of a frequency as low as 10 c/s to be counted if the input voltage is at least 15 V. At still lower frequencies sinusoidal signals may be counted if the input amplitude is increased and if a clipper diode is incorporated in the input circuit to render the waveform suitable for triggering the auxiliary pulse shaping circuit by increasing the slope of the pulse edges. The value of the input capacitor used may also be increased at low frequencies.

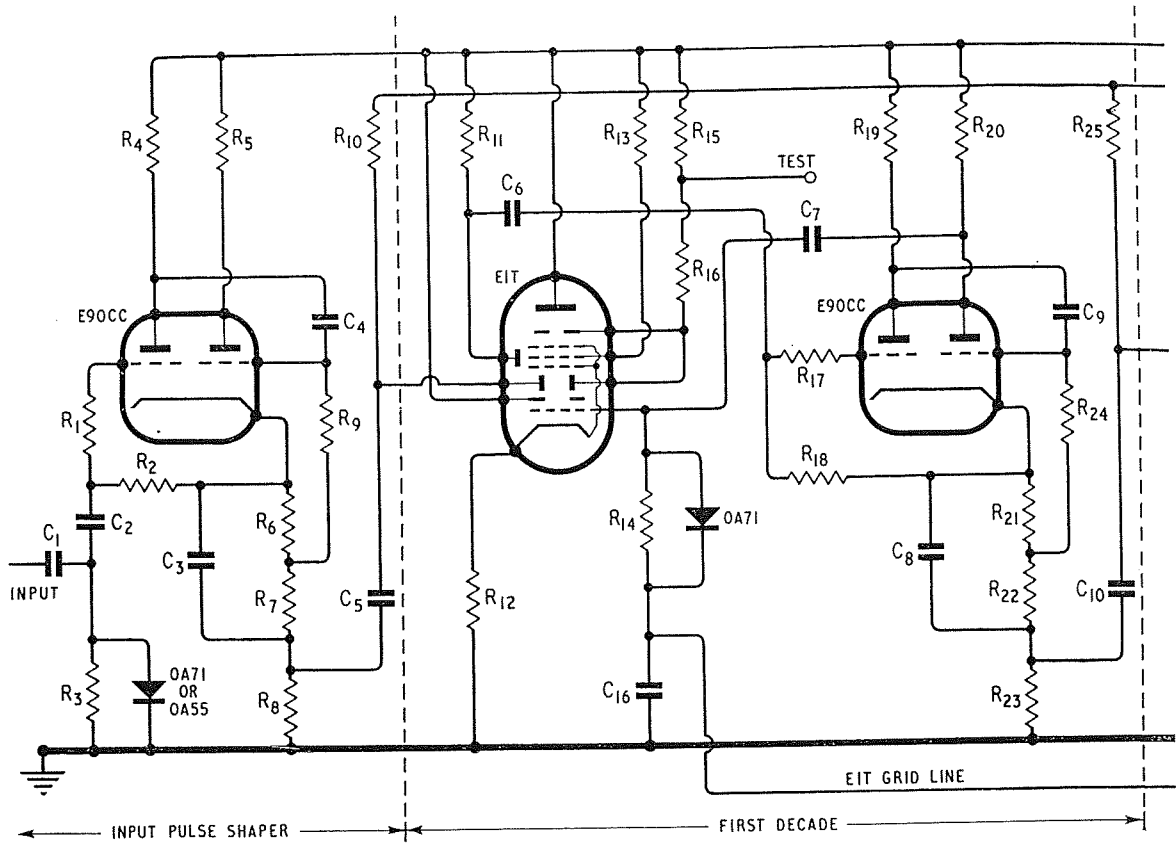

<i>Resistors</i>		R_7	2.7 k Ω	2%	1/4 W	$R_{15} = R_{30}$	10 k Ω	10%	1/2 W
R_1	5.6 k Ω	R_8	1 k Ω	1%	1/8 W	$R_{16} = R_{31}$	1 M Ω	1%	1/2 W
R_2	560 k Ω	R_9	100 k Ω	1%	1/4 W	$R_{17} = R_{32}$	5.6 k Ω	10%	1/2 W
R_3	39 k Ω	R_{10}	15 k Ω	2%	1/8 W	$R_{18} = R_{33}$	560 k Ω	10%	1/2 W
R_4	39 k Ω	$R_{11} = R_{26}$	39 k Ω	10%	1/2 W	$R_{19} = R_{34}$	39 k Ω	2%	2 W
R_5	3.3 k Ω	$R_{12} = R_{27}$	15 k Ω	1%	1/8 W	$R_{20} = R_{35}$	3.3 k Ω	2%	1/8 W
R_6	4.7 k Ω	$R_{13} = R_{28}$	47 k Ω	5%	1/2 W	$R_{21} = R_{36}$	4.7 k Ω	2%	1/4 W
		$R_{14} = R_{29}$	330 k Ω	10%	1/2 W				

Fig. 5.13 A complete two decade counting

5.8 A COMPLETE 30 KC/S CIRCUIT

Fig. 5.13 shows the circuit of a two decade EIT counter^(1, 5, 6) which can count pulses at frequencies up to 30 kc/s. It is based entirely on the circuits which have just been discussed with the addition of a suitable power supply.

The first part of the circuit to the left of the first dotted line is a pulse shaping circuit which feeds the first EIT tube. If necessary the circuit may be preceded by the auxiliary pulse shaper of Fig. 5.12, in which case C_1 , C_2 , R_3 and the diode in parallel with R_3 in Fig. 5.13 may be omitted. The circuits

between any two of the dotted vertical lines in Fig. 5.13 form one complete decade including the coupling and resetting circuits. Any number of similar decades could, of course, be added after the circuit of Fig. 5.13, but the values of the potential divider resistors and the power supply should be modified, however, if more than seven decades are to be used.

The switch S_1 normally connects the EIT grid line to the +11.9 V tapping on the potential divider. If S_1 is used to momentarily connect the EIT grid line to a supply of -60 V, the EIT tubes are cut off and the electron beam in each tube is

EIT DECADE COUNTING CIRCUITS

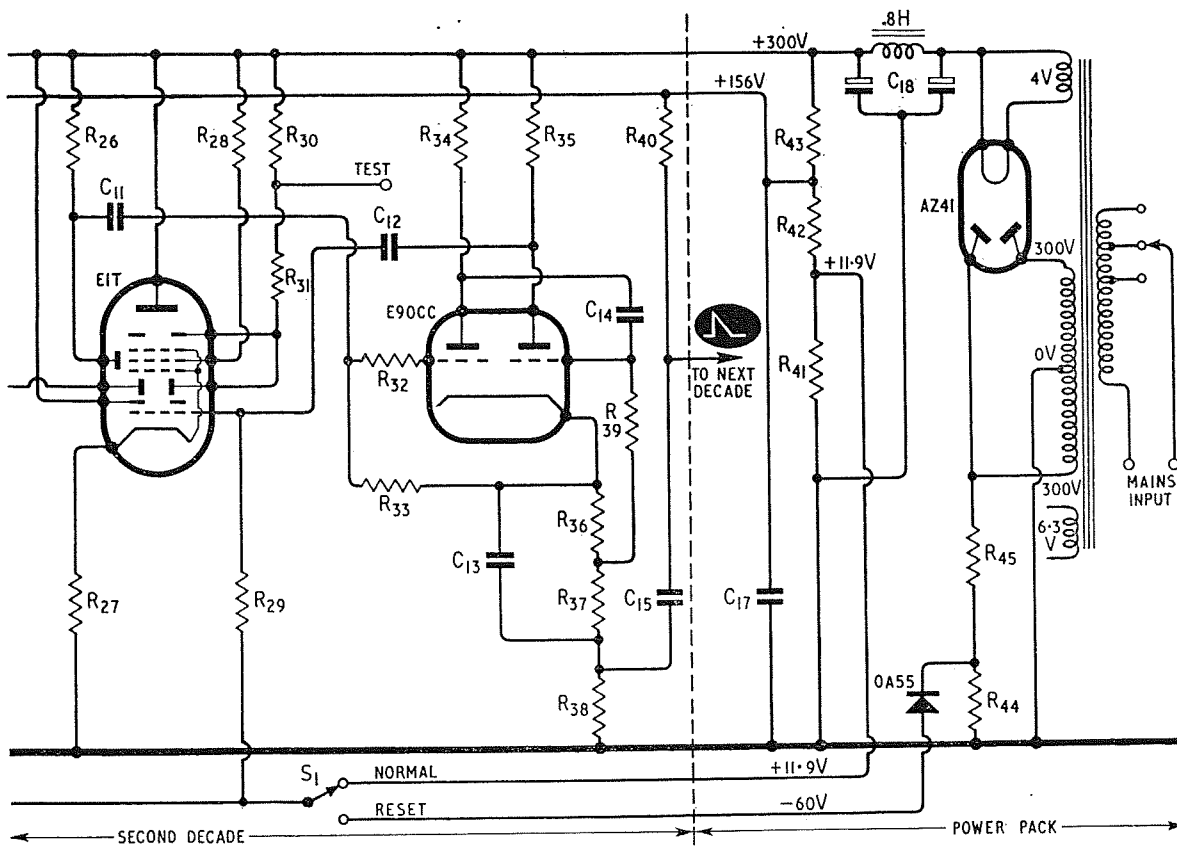

$R_{23} = R_{38}$	1 k Ω	1%	1/8 W
$R_{24} = R_{39}$	150 k Ω	2%	1/8 W
$R_{25} = R_{40}$	15 k Ω	2%	1/8 W

Capacitors

C_1	470 pF	10%
C_2	6800 pF	10%

C_3	82 pF	2%
C_4	39 pF	5%
C_5	6,800 pF	10%
$C_6 = C_{11}$	220 pF	10%
$C_7 = C_{12}$	6,800 pF	10%
$C_8 = C_{13}$	68 pF	2%
$C_9 = C_{14}$	68 pF	2%
$C_{10} = C_{15}$	680 pF	5%

C_{16}	0.39 μ F	20%
C_{17}	0.15 μ F	20%
C_{18}	2 \times 50 μ F	400 V
R_{41}	5.6 k Ω	1% 1/8 W
R_{42}	68 k Ω	1% 1 W
R_{43}	68 k Ω	1% 1 W
R_{44}	15 k Ω	10% 1 W
R_{45}	330 k Ω	10% 1 W

circuit for frequencies up to 30 kc/s

returned to the zero position by the same process as that discussed previously.

The power supplies need not be stabilised provided that the +156 and the +11.9 voltage lines are obtained from the +300 V supply by means of a potential divider such as that shown. Any fluctuations which occur in the mains voltage will then alter all of the supply voltages by the same percentage. This will have no noticeable effect on the operation of the tubes for normal variations of the mains voltage ($\pm 10\%$). Such circuits have been found to operate reliably at mains voltages between 140 and 270 V, but prolonged operation at

such extremes might impair the life of the tubes^(5, 6). It is, however, most important to ensure that the resistors in the potential divider chain have tolerances not exceeding $\pm 1\%$; wire wound resistors are especially suitable.

An 0A71 diode (or an 0A55 or 1N86) is placed in parallel with the resistor R_{14} . No diode need be placed across the corresponding resistor, R_{29} , in the second decade or across the corresponding resistor in any succeeding decade which may be added to the circuit. During the intervals between the negative going resetting pulses which are fed to the control grids of the EIT tubes, the potentials of these grids

ELECTRONIC COUNTING CIRCUITS

depend on the counting speed. This effect is only appreciable in the first stage where the counting speed may be high. A diode is therefore placed in parallel with R_{14} of the first decade so that the potential of the E1T control grid is kept constant (except during flyback) whatever the counting speed may be. Except for the presence of this diode in the first stage, all of the decades are identical.

In any decade except the first, 10% components may be used in the multivibrator circuits only provided that the values of coupling capacitors such as C_{14} and grid leaks such as R_{39} are increased to 82 pF and 180 k Ω respectively and provided that the output pulse amplitude to the next decade is adjusted to $13.6 \pm 2\%$ by adjustment of the value of R_{38} . This adjustment may have to be repeated from time to time, since 10% resistors alter somewhat in value during life. It is therefore normally much more convenient to use the close tolerance resistors specified for the circuit. It is, in any case, essential to use close tolerance resistors in the cathode and anode circuits of the counter tubes.

In order to facilitate testing of the circuits, the anode load of each E1T tube may be split into two parts as shown in Fig. 5.13. An oscilloscope may be connected to the test point. If the stage is operating correctly, the oscillogram should show ten distinct steps. The effect of variations in the mains voltage on the tube may thus be investigated.

5.9 CIRCUIT FOR USE AT UP TO 100 KC/S

If the E1T tube is to be used to count at up to 100,000 pulses per second, it is essential that each counting operation should be completed within 10 μ sec. This limitation is imposed on both the resetting operation and on the normal forward movement of the electron beam as it moves from the zero to the ninth positions. Carefully designed input and resetting circuits are therefore essential for high speed operation of E1T tubes.

5.9.1 Input Circuit Design

The leading edge of the pulse fed to the E1T should be very steep so as to occupy the minimum amount

of time. The trailing edge cannot be very steep or it will immediately reset the E1T to its previous state. It must, however, be as steep as is consistent with reliable counting. In addition the trailing edge should decrease more or less linearly with time in order that the shortest trailing edge which will not reset the tube to its former state can be used.

The application of the leading edge of the pulse to the E1T deflector plate results in the electron beam being suddenly moved to the next stable position. The anode and x'' deflector plate voltage will not decrease immediately to their value at the new stable state because of the effect of the stray capacitance C (see Fig. 5.7). If the beam is to remain in its new position, it is important to ensure that the trailing edge of the input pulse does not decrease at a rate which is greater than that at which the anode voltage can decrease. The rate of change of the anode voltage is determined by the current which can be taken by the E1T tube to discharge the stray capacitance, C . This current, I_c , is the difference between the maximum tube current at the particular peak of the characteristic concerned and the current flowing through the load resistor at the existing instantaneous voltage. I_c is thus the height of the peak of the characteristic above the load line.

The charge of the stray capacitance, C , is equal to CV coulombs where V is the potential difference across the capacitor. If it is assumed that I_c and the slope of the trailing edges of the pulses are constant, the time, t , taken by the anode and x'' potential to decrease by an amount V volts as C discharges is given by the equation^(1, 6, 8):

$$t = \frac{CV}{I_c} \text{ sec}$$

The minimum possible duration of the trailing edge is equal to this time, t .

It should be noted that t is inversely proportional to I_c . The presence of the horizontal slot in g_4 (see Fig. 5.4) raises the value of I_c when the digit being indicated is five or more. This extra slot thus enables the duration of the trailing edge of the counting pulse to be kept as short as possible and the maximum counting speed to be attained.

In the 100 kc/s circuit to be described (Figs. 5.14 and 5.15), the total stray capacitance, C , by-passing

the anode is about 23 pF. The smallest positive peak of the characteristic (see Fig. 5.6) is that situated between the stable points where the digits zero and one are indicated. For the average tube this peak is about 70 μ A above the load line. If one substitutes these values of C and I_c in the above equation together with the value of about 14 V between the successive stable positions, one finds that the minimum duration of the trailing edge of the pulse, t , is 4.6 μ sec^(1, 6, 8). In some EIT tubes this first peak is smaller, but the steps can be completed in 10 μ sec provided that no peak has a value of I_c less than 35 μ A.

5.10 A PRACTICAL 100 KC/S INPUT CIRCUIT

The circuit shown in Fig. 5.14 can be used to convert input pulses of arbitrary waveform into pulses of the correct amplitude and duration for feeding into an EIT tube^(1, 6, 8). The trailing edges of the output pulses from this circuit are linear. The total duration of each output pulse is slightly less than 10 μ sec so that operation at 100 kc/s is possible. The pulse shape and amplitude are substantially independent of changes in the tube characteristics.

The E90CC (or E92CC) double triode acts as a pulse squarer. It is used in a monostable multivibrator circuit in which the triode $V1a$ is normally conducting and $V1b$ is normally cut off owing to the differences in their quiescent grid voltages. When a negative going input pulse is applied to the circuit, $V1a$ is cut off and $V1b$ conducts. The anode voltage of $V1b$ drops from about 173 to 130 V until the circuit returns to its quiescent state at some point in the positive going trailing edge of the input signal. The current taken by $V1b$ in the fraction of a second during which it conducts is made equal to the normal quiescent current of $V1a$. The supply voltage at the lower end of R_4 is, therefore, independent of the counting frequency.

The pulse squarer thus provides a negative going pulse of 43 V amplitude for the shaping circuit.

5.10.1 The Pulse Shaper

The capacitor C_4 and the resistor R_{12} of Fig. 5.14 differentiate the square wave so as to provide one

negative going and one positive going peak. The negative going peak is removed by the diode $V2a$ and the positive going peak is applied to the anode of $V2b$. The capacitor C_6 together with any associated stray capacitance is charged from the cathode of $V2b$. The output voltage rises quickly to about 170 V, thus giving the desired 14 V amplitude over the quiescent value of 156 V.

C_4 and R_{12} are chosen so that the anode potential of $V2b$, after reaching its peak, will decrease faster than the cathode voltage of the diode which therefore becomes non-conducting. C_6 and the associated stray capacitance therefore starts to discharge through R_{13} and R_{14} and the output potential tends towards +90 V. As soon as it drops to +156 V, however, the diodes conduct and the output potential then remains constant. Thus the trailing edge of the pulse is reasonably linear—as has been verified by oscillograms at 50 kc/s and 100 kc/s^(6, 8).

It is important that the stray capacitance between the output of the circuit of Fig. 5.14 (including the EIT input circuit) and earth should be kept to a minimum, as variations in this capacitance will affect the amplitude and duration of the pulse fed into the EIT. The stray capacitance in the multivibrator circuit should also be kept to a minimum. The leading edge of the output pulse from Fig. 5.14 has a duration of about 1 μ sec and the trailing edge a duration of about 8 μ sec. The pulse duration will be somewhat smaller when the beam is near the x' electrode, since this electrode takes some current and effectively acts as a resistance in parallel with R_{13} and R_{14} . The reduction in pulse duration when the tube is indicating a large digit is not important, since the height of the peaks above the load line is greater in the case of the large digits (see Fig. 5.6).

The input pulses to the circuit of Fig. 5.14 should be of at least 15 V in amplitude and at least 2 μ sec in duration. They may be sinusoidal, square or triangular in shape. If the circuit is to be fed with a sinusoidal voltage of a frequency which is less than about 20 c/s, either a fairly large input voltage should be used or alternatively the value of C_1 should be increased. If pulses of a duration less than 2 μ sec are fed into the circuit, the multivibrator will be triggered, but the amplitude of the output pulse will be somewhat reduced.

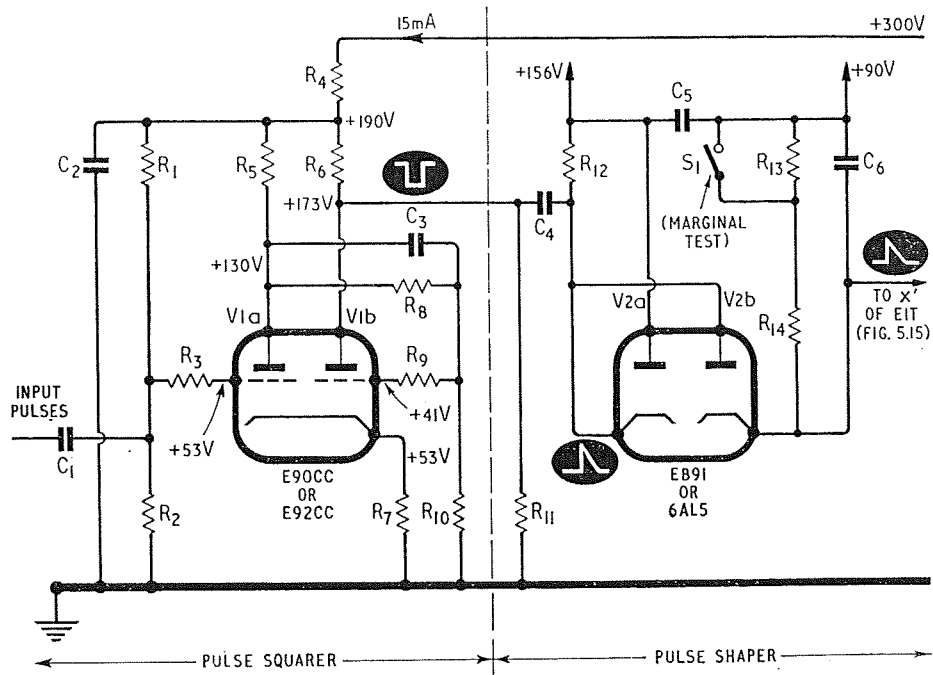

Fig. 5.14 An input circuit for the operation of the EIT at frequencies up to 100 kc/s

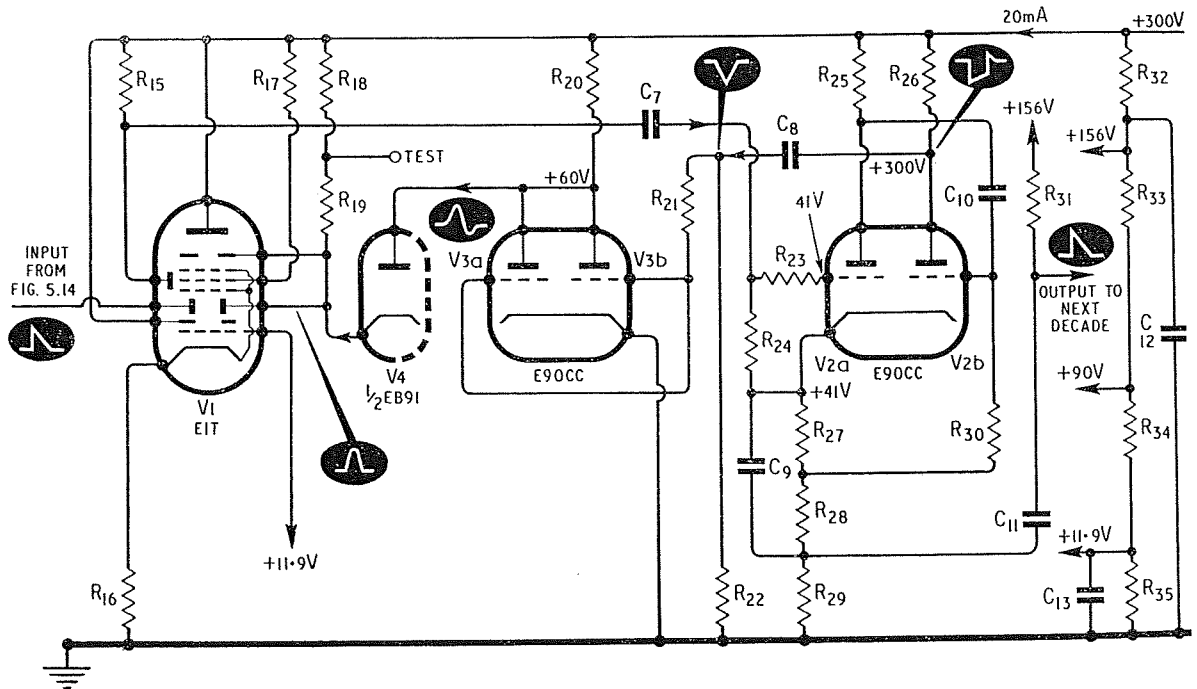

Fig. 5.15 A 100 kc/s EIT reset circuit with facilities for coupling to the next stage. The potential divider on the right-hand side can be used to supply both the above circuit and that of Fig. 5.14

EIT DECADE COUNTING CIRCUITS

Resistors					Capacitors	
1	82 kΩ	1% 1/2 W	R_{18}	10 kΩ 10% 1/4 W	C_1	2 μF 10% paper
2	33 kΩ	1% 1/4 W	R_{19}	1 MΩ 1% 1/2 W	C_2	0.1 μF 10%
3	1 kΩ	10% 1/4 W	R_{20}	18 kΩ 5% 5 W	C_3	22 pF 10%
4	7.5 kΩ	5% 3 W	(Wire wound)		C_4	47 pF 2%
5	5.6 kΩ	1% 1 W	R_{21}	1 kΩ 10% 1/4 W	C_5	0.01 μF 10%
6	5.6 kΩ	1% 1 W	R_{22}	6.8 kΩ 2% 1/4 W	C_6	39 pF 2%
7	6.8 kΩ	1% 1 W	R_{23}	5.6 kΩ 10% 1/4 W	C_7	220 pF 10%
8	39 kΩ	1% 1 W	R_{24}	560 kΩ 10% 1/4 W	C_8	220 pF 2%
9	1 kΩ	10% 1/4 W	R_{25}	39 kΩ 2% 2 W	C_9	68 pF 2%
10	18 kΩ	1% 1/2 W	R_{26}	3.3 kΩ 2% 1/2 W	C_{10}	68 pF 2%
11	56 kΩ	2% 1 W	R_{27}	4.7 kΩ 2% 1 W	C_{11}	680 pF 5%
12	47 kΩ	2% 1/4 W	R_{28}	2.7 kΩ 2% 1/2 W	C_{12}	0.47 μF paper
13	150 kΩ	2% 1/4 W	R_{29}	1 kΩ 1% 1/4 W	C_{13}	0.47 μF paper
14	680 kΩ	1% 1/4 W	R_{30}	150 kΩ 2% 1/4 W		
15	39 kΩ	10% 1/2 W	R_{31}	15 kΩ 2% 1/4 W		
16	15 kΩ	1% 1/4 W	R_{32}	33 kΩ 1% 1 W		
17	47 kΩ	5% 1/2 W	R_{33}	15 kΩ 1% 1/2 W		
			R_{34}	18 kΩ 1% 1 W		
			R_{35}	2.7 kΩ 1% 1/4 W		

* R_1 may be replaced by two 15 kΩ 2% 2 watt resistors connected in parallel if desired.

10.2 Marginal Tests and Tube Selection

The switch S_1 in Fig. 5.14 enables a check to be made as to whether any particular EIT tube will operate satisfactorily at high frequencies in the circuit. If S_1 is used to short circuit R_{13} , the duration of the trailing edges of the pulses will be reduced by about 18%. If the circuit operates satisfactorily under these conditions, it may be expected to function satisfactorily when S_1 is open. These marginal tests should preferably be carried out at several input frequencies, say 20 c/s, 1 kc/s and 10 kc/s.

This test enables EIT tubes which are suitable for high speed operation to be selected. Other tubes which do not function satisfactorily at high frequencies may be used in decades operating at frequencies up to 30,000 pulses per second.

10.11 Flyback Circuit for 100 kc/s Stage

It has been shown previously that if the electron beam is cut off to cause flyback, the resetting operation requires more than 20 μsec. If a circuit is to count at frequencies up to 100 kc/s, another method of resetting the electron beam must be employed in which the operation is completed in not more than 10 μsec.

The circuit of Fig. 5.15 shows a suitable resetting and coupling circuit^(1, 6, 8) for high speed operation. The monostable multivibrator V_2 is identical with that used in the circuits of Figs. 5.10 and 5.13. It is

fed from the reset anode via C_7 . The negative going pulse at the anode of V_2b (which was used for cutting off the EIT tube in the 30 kc/s circuits) is differentiated by C_8 and R_{22} and the resulting pulses are applied to both grids of the double triode V_3 . Both sections of this valve are cut off and the anode voltage increases rapidly. V_4 conducts and passes the positive going pulse to the anode and x'' deflector plate of the EIT. The beam is therefore rapidly deflected to the zero position. When V_3 returns to its normal conducting state, the resulting negative pulse cannot pass through the diode to the EIT anode. In actual practice the EIT anode does receive a small part of the negative going pulse owing to the anode to cathode capacitance of V_4 which forms a capacitive voltage divider in conjunction with the anode by-pass capacitance of the EIT.

The anode and x'' potential of the EIT tube in the circuit of Fig. 5.15 can rise much more quickly than in the circuits in which flyback is effected by beam cut off. When the diode of Fig. 5.15 conducts, the 1 MΩ resistor R_{19} is effectively in parallel with the combined resistance of R_{20} (18 kΩ) and the forward resistance of the diode. The latter is small and the time constant which controls the rate of rise of the EIT anode potential is therefore approximately 18 kΩ multiplied by the stray anode to earth capacitance. In the 30 kc/s circuits the corresponding time constant is the slightly smaller stray EIT anode capacitance multiplied by 1 MΩ (the tube anode resistor). Thus the time constant has been

ELECTRONIC COUNTING CIRCUITS

reduced by a factor of nearly fifty in the 100 kc/s flyback circuit. It should be noted that the use of V_4 in the 100 kc/s circuit increases the stray anode capacity of the E1T from about 16.5 pF to about 23 pF.

It is important that the E1T anode potential should be raised sufficiently during flyback for the beam to return to the zero position, but if it is raised too high, the beam will take too long to arrive at the zero position for the resetting operation to be completed within the permitted 10 μ sec.

5.12 PRACTICAL DETAILS

The 100 kc/s input circuit is normally followed by a number of 30 kc/s stages of the type shown in Fig. 5.13.

The heater supplies for the two diodes of Fig. 5.14 and for the single diode of Fig. 5.15 require special mention. These supplies should preferably be obtained from a separate transformer winding, one side of which is connected to the +156 V line. This reduces leakage between the diode cathodes and heaters. Alternatively suitable semiconductor diodes could be used, but care should be taken to ensure that they have an adequate peak inverse voltage rating.

Care should be taken that all of the components used are within the specified tolerances or the input pulses may not have the desired shape and duration.

The fairly high value of the E1T cathode resistor greatly reduces any changes in the tube characteristics due to ageing. The ageing of the resistors in the common potential divider chain may result in a variation in the height of the peaks of the characteristic; under marginal conditions when the tube employed in the 100 kc/s stage has a low value of I_c , this may lead to counting errors. It is therefore important that the first E1T tube should be selected carefully.

If desired, reset facilities may be added to the 100 kc/s circuit by using the same technique as shown in the circuit of Fig. 5.13.

The E90CC tube is a special quality valve which has the same base connections as the ECC91 and the 6J6 and very similar characteristics.

The 30 kc/s and 100 kc/s circuits described above are normally the only ones required in an E1T scaler (with the possible exception of a circuit for coupling an E1T to an electro-magnetic counter). These decade circuits are conveniently constructed as plug in modules for ease of servicing. Such modules are available commercially from the manufacturers of the E1T tube^(9, 10). A 30 kc/s E1T module with the associated E90CC tube is shown in the photograph.

5.13 RANDOM PULSE COUNTING

If random pulses are to be counted, the average resolving time of the 30 kc/s circuit of Fig. 5.13 may be reduced by the use of the input circuit of Fig. 5.14 with the 30 kc/s flyback circuit (Fig. 5.10)⁽¹¹⁾. R_{14} of Fig. 5.14 should be increased to 1.2 M Ω and R_{13} omitted so that the trailing edges of the pulses produced are long enough to operate any E1T tube.

The resolving time when flyback is not involved may thus be decreased from about 33 to 13 μ sec. This applies to nine out of the ten positions, but in the tenth position (when flyback occurs), the resolving time remains about 33 μ sec and this limits the maximum counting speed for evenly spaced pulses to 30 kc/s. The effective resolving time for randomly spaced pulses is, however, decreased to about 15 μ sec.

5.14 10 KC/S E1T CIRCUIT

A circuit operating on rather different principles from those discussed previously is shown in Fig. 5.16⁽¹²⁾. It may be fed from the input circuit of Fig. 5.11 or from a previous decade. One advantage of this circuit is that 10% components can be used throughout, whereas the faster E1T circuits require many 1% and 2% tolerance components. In addition, rather fewer coupling components are required.

The triode V_2 shares a common cathode resistor, R_2 , with the E1T tube, V_1 . The flow of the E1T cathode current through R_2 produces a positive voltage which biases the cathode of V_2 to cut off, since the grid of V_2 is returned to earth via R_4 .

When the beam is in position 'nine' and an additional input pulse is received, the beam will be

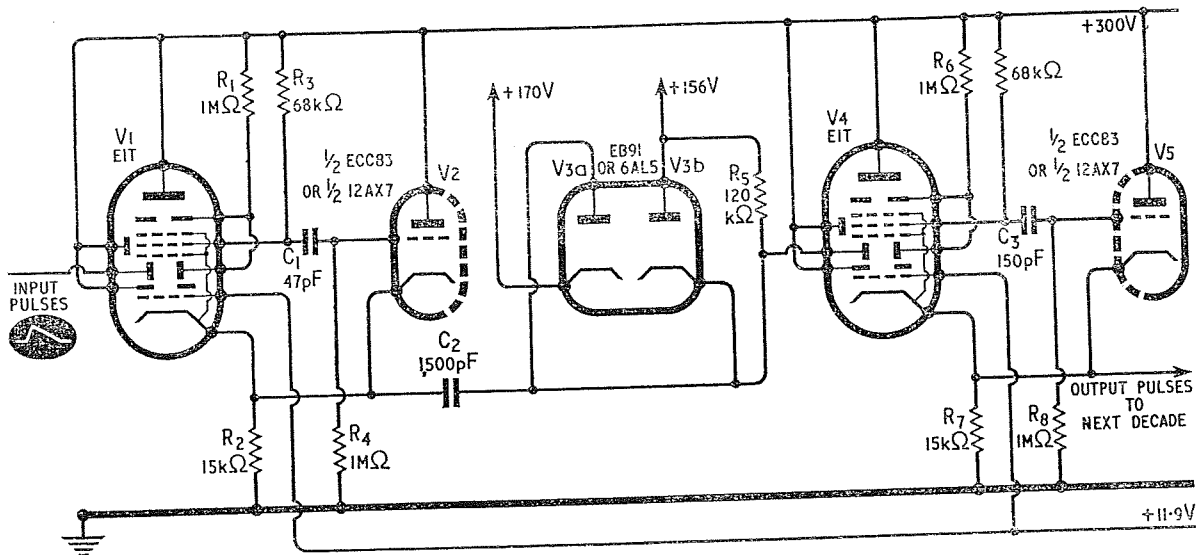

Fig. 5.16 An EIT circuit for operation at frequencies up to 10 kc/s

deflected so that it strikes the reset anode, a_1 , instead of the g_4 electrode. The current passing through R_3 therefore falls and the potential of the electrode g_4 rises. This rise of potential is fed as a pulse to the grid of the triode V_2 via the capacitor, C_1 . The triode conducts and the voltage across the common cathode resistor, R_2 , rises. This rise of potential of the cathode of the EIT is sufficient to cut off the tube and the electron beam is reset to the zero position by the same process as in the 30 kc/s circuit. The reset anode is not employed in this circuit.

The impulse from the cathodes passes through C_2 to the x' deflector plate of the succeeding EIT tube. The resistor R_5 maintains the quiescent potential of the x' deflector plate at +156 V. If the voltage at the cathodes of V_1 and V_2 becomes more positive, the pulse which passes through C_2 is limited by V_3a to a maximum value of +170 V above earth. Thus the desired positive going 14 V pulse for V_4 is obtained. Similarly when a negative pulse is fed through C_2 , V_3b limits the minimum potential to the quiescent value of +156 V.

The time taken for flyback (that is, for the anode and x'' potential to rise) in the circuit of Fig. 5.16 after the tube has been cut off is as long as in the circuit discussed previously (Fig. 5.10). In addition, the voltage of g_4 takes a short time to rise and the C_1R_4 circuit delays the pulse considerably. The

maximum operating frequency is therefore limited to about 10 kc/s.

In any stages after the first, the value of the capacitor corresponding to C_1 may be increased to 150 pF, since the maximum operating frequency is lower. The circuit of Fig. 5.16 may be modified to incorporate a resetting circuit.

5.15.2 KC/S CIRCUIT

A number of attempts have been made to design a circuit for operation at fairly low frequencies which does not require any valve coupling stage between each two EIT tubes^(2, 6, 13). A typical circuit of this type is shown in Fig. 5.17 in which a double diode is the only valve employed between each two EIT tubes. Germanium semiconductor diodes were not used because their inverse resistance varies with temperature and this would result in variations of the amplitude of the pulses fed to the next EIT tube. Silicon semiconductor diodes are now available and these could be used to replace the EB91 valves so as to avoid the use of valves in the coupling circuits.

The resetting action is accomplished by means of the capacitor which connects the reset anode to the main anode. When the beam strikes the reset anode, the potential of this electrode falls and this fall is coupled into the main anode circuit so that the beam is moved still farther towards the x' electrode. After

ELECTRONIC COUNTING CIRCUITS

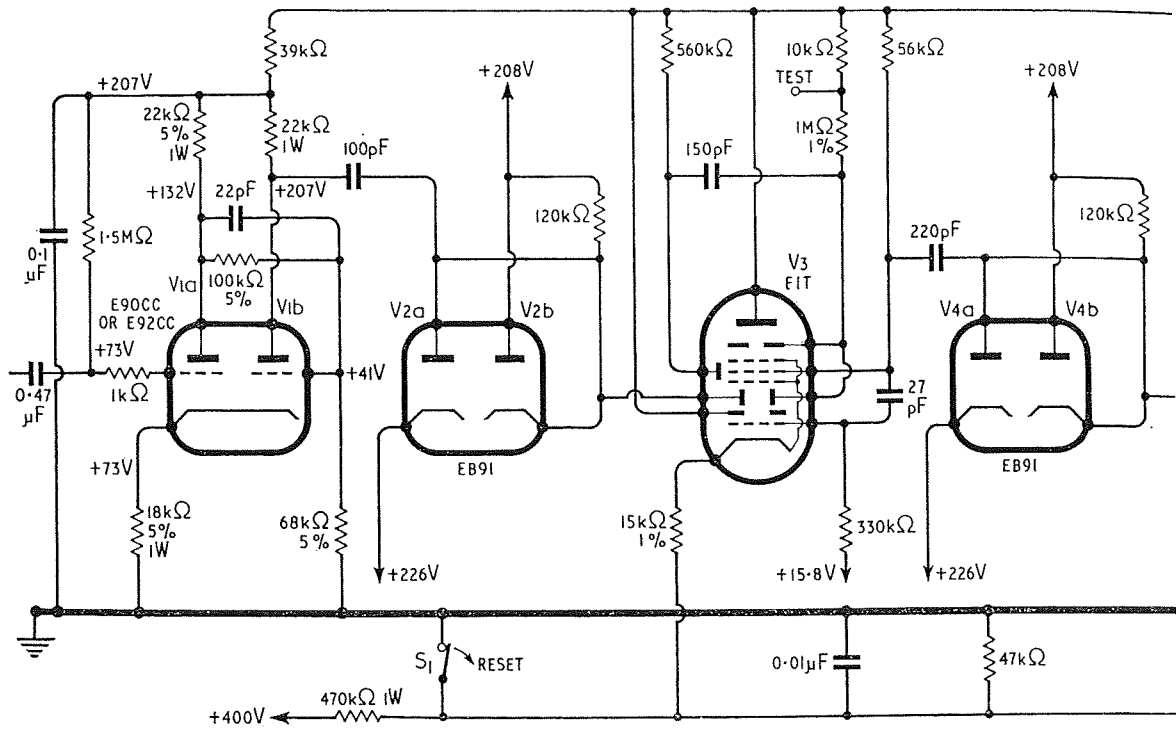

Fig. 5.17 A 2 kc/s EIT circuit which does not require a coupling amplifier.

a short time the anode and x'' voltage rises to the H.T. supply potential and the beam moves back across the tube. If the value of the coupling capacitor connecting the two anodes is large enough, the main anode potential will continue to rise until the digit zero is indicated. The maximum operating frequency depends on the value of the coupling capacitor, but if this is too small, the beam will be reset to an intermediate position. It has been found that the value of the coupling capacitor may be reduced somewhat if the beam current is reduced during flyback. This may be achieved by applying the differentiated g_4 voltage to the control grid of the counter tube V_3 in Fig. 5.17. This prevents the reset capacitor from being recharged too quickly. The maximum operating frequency is approximately doubled by this technique⁽¹³⁾, but there is no point in reducing the beam current in any stage after the first. A smaller value of coupling capacitor is used in the first stage than in subsequent stages.

The 'carry' pulse which operates the next decade is obtained from the g_4 electrode. When the beam is deflected from position nine, it leaves g_4 and the

potential of this electrode therefore rises. When the beam returns V_{g_4} falls again. These voltage changes are differentiated in order to obtain a positive pulse followed by a negative pulse. A diode is used to remove the negative pulse and the remaining positive pulse is limited by the other diode. In all stages except the first a 47 pF capacitor is connected from the main anode to earth so that the g_4 pulse is steep enough to operate the next decade.

The reset anode resistor must have a value greater than a certain minimum or the beam will not be reset to zero. The large value of this resistor can, however, cause premature flyback when the beam moves from position eight to nine, because a small fraction of the beam will reach the reset anode. This is less likely to happen if a fairly high supply voltage is used so that the beam is focussed more accurately. The minimum supply voltage at which most tubes would operate satisfactorily was found to be 200–250 V, but some tubes required a 350 V supply when used in the circuit of Fig. 5.17 in order to avoid position nine being missed. The recommended H.T. supply voltage for this circuit is 400 V.

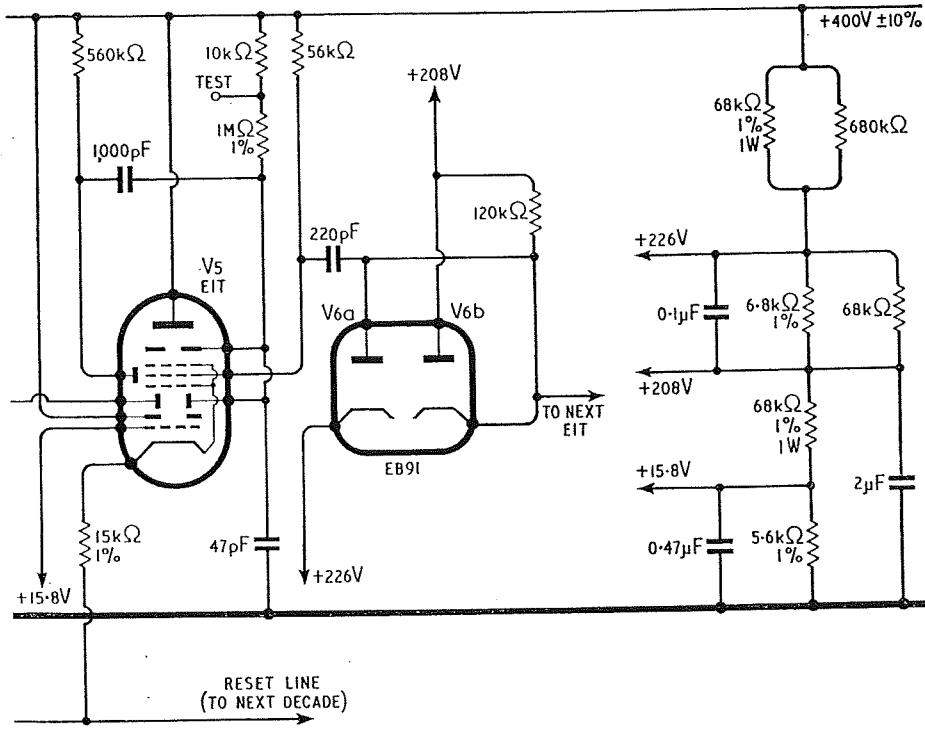

Components may be of 10% tolerance unless otherwise indicated

A suitable input stage is also shown in Fig. 5.17. It consists of a double triode squarer followed by a double diode pulse shaper. $V1a$ is normally conducting and $V1b$ is normally cut off. Negative going input pulses are required to cut $V1a$ off. A negative going pulse first appears at the anode of $V1b$, but is prevented from reaching $V3$ by the presence of $V2b$. When the circuit returns to its quiescent state, $V2a$ limits the positive going pulse which is fed to the EIT.

The circuit should be fed with input pulses of not less than about 20 V in amplitude and not less than about 3 μ sec in duration. Sine waves of not less than 15 V R.M.S. amplitude may be used if their frequency is between 20 and 2,000 c/s.

The circuit is reset by the application of a positive pulse to the EIT tube cathodes. This method can also be used for the 30 kc/s circuit of Fig. 5.13. A suitable potential divider is shown for supplying the required voltages to the Fig. 5.17 circuit when up to four decades are used. The diode heaters should be fed from a separate transformer winding, one side of which is connected to the +208 V line.

5.16 PREDETERMINED COUNTING USING THE EIT

The same electrodes of the EIT are being used whatever the state of the count. It is therefore convenient to obtain an output pulse from an EIT scaler only when the decades are being reset to zero.

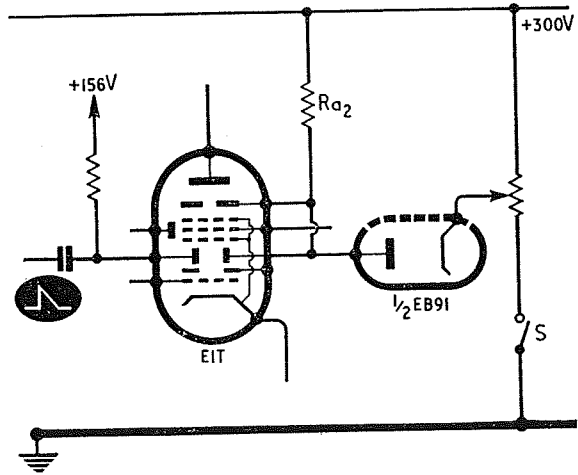
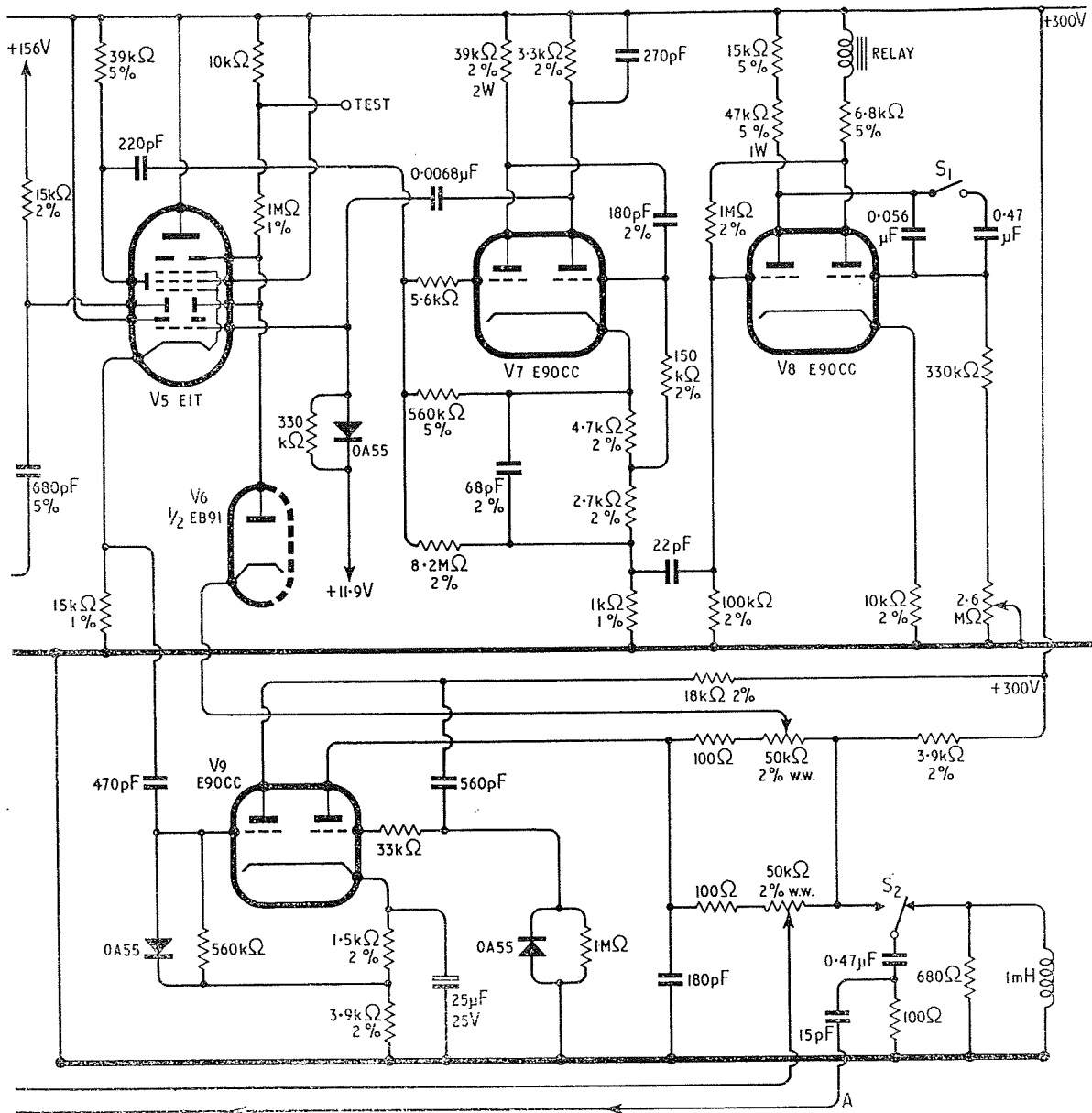

Fig. 5.18 A circuit for pre-setting an EIT



to the first decade shown above. Component tolerances not shown are 10%

In order that a pulse may be obtained after any predetermined number of counts, some means must be provided for presetting the scaler to any desired number of counts. If, for example, a four decade scaler is preset to 5,672, an output pulse can be obtained after $10,000 - 5,672 = 4,328$ pulses have been applied at the input. Arrangements may be made for the output pulse to automatically preset the scaler to the number 5,672 so that the process can be repeated many times.

The E1T tube may be preset to any desired number by means of the type of circuit shown in Fig. 5.18. When the switch S is open, the diode is non-conducting and has no effect on the operation of the tube. When S is closed the diode will conduct if its cathode is at a lower potential than the E1T anode. The flow of current through R_{a_2} causes the anode voltage to fall almost to the potential of the slider of the variable resistor. When S is opened, the beam will move to its next stable position, the anode voltage being little different from that of the potentiometer slider immediately before S was opened. After S has opened the diode cathode potential rises to the H.T. supply voltage and the diode becomes non-conducting again.

A number of such decades may be cascaded with separate potentiometers connected to a common switch. Each tube can thus be preset to the desired digit which has been pre-selected by means of the corresponding potentiometer. In practical circuits the presetting switch is an electronic device.

The full circuit of a two decade predetermined counter is shown in Fig. 5.19^(6, 14, 15). This circuit is based on the 30 kc/s E1T counter described previously (Fig. 5.13), but slight modifications have been made. The g_4 electrodes of the E1T tubes are connected directly to the H.T. + line in order to avoid negative feedback during the resetting of the beam. The amplitude of the required input pulse is thereby increased from a mean value of 13.6 to a mean value of 14.7 V. The larger pulse is obtained by shunting part of the cathode resistor in the input circuit by 100 pF instead of 82 pF. In all decades except the first, the pulse amplitude is increased by the presence of the capacitors which by-pass the anode loads of the right hand triodes of the coupling circuits.

These capacitors also serve to prevent "sticking" of the electron beam at position nine when the presetting potentiometer is adjusted so that the beam passes between the end of g_4 and the reset anode^(6, 14).

5.17 THE ELECTRONIC SWITCH

An electronic presetting stage, $V9$, is used instead of the switch S of Fig. 5.18. The left-hand triode of $V9$ is normally conducting whilst the right-hand triode is normally cut off. When the final E1T, $V5$, is reset by beam cut off, the negative going pulse produced at its cathode is fed to $V9$. The pulse is amplified and phase inverted by the left-hand section of this valve and the resulting positive going pulse is used to render the right-hand section of $V9$ conducting. The anode voltage of this triode therefore suddenly falls from 300 to 95 V. This is low enough for presetting to take place to the digits determined by the positions of the sliders of the 50 k Ω potentiometers. OA55 diodes are employed in each of the grid circuits of $V9$ to ensure that the quiescent grid potential is reached at high counting rates.

The 100 Ω resistors in series with the presetting potentiometers serve to prevent excessive interaction of the potentiometer settings owing to the inductance of these wire wound components.

The scaler may be preset manually by means of S_2 . When this switch is pressed, the 0.47 μ F capacitor connected to it is suddenly charged so that the voltage of the 50 k Ω presetting potentiometers quickly falls and the beam in each tube moves to the ninth position. When S_2 moves back to its normal position, the capacitor discharges through the 1 mH choke and the 100 Ω resistor producing a negative going pulse which is fed to the input of the scaler along the wire ABC and causes the scaler to momentarily indicate zero. During this process the last E1T is reset and this initiates the presetting by means of $V9$.

5.18 THE OUTPUT STAGE

The output pulse from the tapping on the cathode resistor of $V7$ is applied to the monostable circuit

of V8. The 2.6 MΩ variable resistor in the grid circuit of V8 can be used in conjunction with the switch S₁ to vary the time for which the relay is energised from 20 msec to 2 sec. The maximum repetition frequency of the output stage is about 20 c/s, but the relay can be replaced by a thyatron circuit in order to achieve the maximum repetition frequency of the counter of about 3 kc/s. This is, of course, the maximum number of batches which can be counted per second, but the maximum rate at which the input pulses can be counted is 12.5 kc/s.

The power supply for the circuit of Fig. 5.19 can be identical to that used for the 30 kc/s circuit of Fig. 5.13, but the -60 V supply used for resetting the decade tubes of Fig. 5.13 is not required. The EB91 diodes connected to the E1T anodes must be fed from a separate 6.3 V transformer winding, one side of which is connected to the +156 V line. The EB91 diodes should be mounted close to the E1T tubes to which they are connected and the internal screens of the diodes should be connected to the +300 V line to avoid pulses in one section of the double diode from being picked up in the other.

The input pulses required for the operation of Fig. 5.19 have similar amplitudes and durations to those required for the circuit of Fig. 5.13. If

necessary the circuit of Fig. 5.12 may be used to shape the input pulses before they are fed into the preset counter.

The optimum setting of the potentiometers for any digit will vary slightly from decade to decade according to the individual characteristics of each E1T tube used. In order to adjust the potentiometer settings, a 3 kc/s pulse generator should be connected to the input and the potentiometer which presets the units decade should be calibrated first, the other potentiometers being turned in a clockwise position to the ends of their tracks (corresponding to positions 9). The optimum position of the potentiometer for presetting a tube to any digit is midway between the points at which the tube is just preset to the adjacent digits.

The other potentiometers are then calibrated in a similar way, but the potentiometers of the previous stages are set to zero during this operation. The input pulse frequency may be raised to 12.5 kc/s during the calibration of the potentiometers which preset the decade tubes which indicate the hundreds and the thousands. The adjustment of the potentiometer which presets the thousands tube is somewhat more tedious owing to the slow rate of counting of this tube.

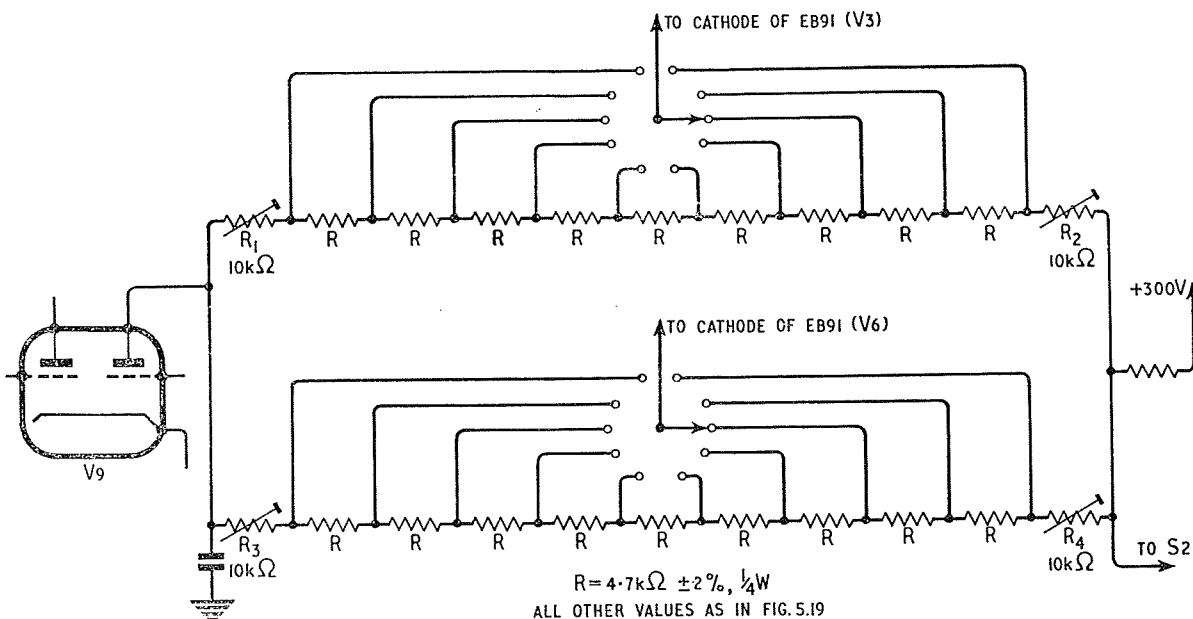

Fig. 5.20 The potentiometers of Fig. 5.19 may be replaced by the above circuit for switched presetting

ELECTRONIC COUNTING CIRCUITS

When an EIT is replaced, the calibration of the potentiometers should be checked. Normally the only adjustment likely to be required is a slight rotation of the scale of some of the potentiometers, but sometimes a new scale may have to be used.

5.19 SWITCHED PRESETTING

A ten way switch may be used to preset each decade instead of a potentiometer. The type of circuit used is shown in Fig. 5.20, this replacing the potentiometers and the $100\ \Omega$ resistors used in the circuit of Fig. 5.19.

The adjustment of the variable resistors of Fig. 5.20 should be carried out with the aid of an oscilloscope and a pulse generator. The oscilloscope is connected to the test point (Fig. 5.19) of the decade being adjusted. The decade tube indicating the units should be adjusted first, then that showing the tens and so on.

When the decade is switched to position zero, the oscillogram should show a descending staircase waveform of ten distinct steps. As the digit to which the stage is to be preset is increased, some of these steps vanish. The potentiometer R_1 (Fig. 5.20) should be adjusted with the appropriate decade switched to position 1, the correct setting being obtained when the transient in the centre of the first step is of equal height above and below the level of the step. R_2 should be adjusted with the decade preset to position 7 so that the first of the three steps on the oscillogram shows a transient which has equal heights above and below the level of the step. The next decade is adjusted in a similar way, R_3 (see Fig. 5.20) being adjusted with this decade preset to one and R_4 with the decade preset to seven.

5.20 THE USE OF AN EIT TO FEED AN ELECTRO-MAGNETIC COUNTER OR RELAY

Each EIT tube can indicate only one digit, but one electro-magnetic counter can indicate a number of digits. In some scalars the input pulses are therefore fed into one or more EIT tubes and the output pulses from the final EIT circuit are counted by the

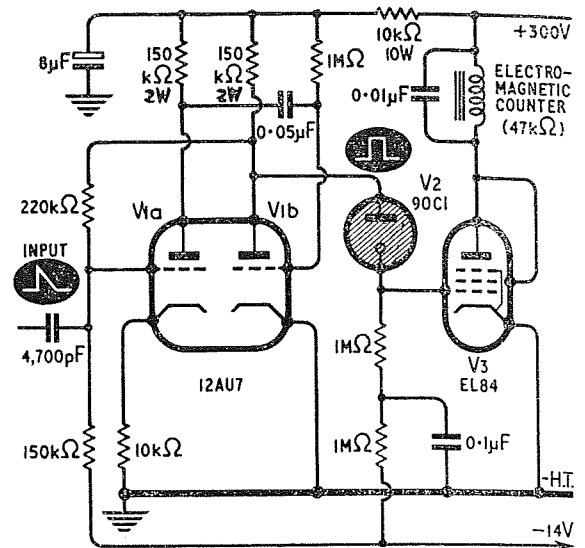

Fig. 5.21 A circuit for the operation of an electro-magnetic counter from an EIT circuit

electro-magnetic counter. The same type of circuit may, of course, also be used to operate a relay.

The output pulses from the EIT circuits such as that of Fig. 5.13 are not able to provide enough power to operate an electro-magnetic counter directly and their duration is measured in microseconds whilst an electro-magnetic counter requires pulses which are about one thousand times longer. A circuit which will both amplify and lengthen the pulses is therefore required. Normally a monostable circuit is used.

One example of a monostable circuit used to operate a relay is the output stage, V_8 , of the predetermined counter shown in Fig. 5.19. The maximum permissible cathode current for the E90CC is, however, 15 mA. If a large relay or an electro-magnetic counter taking a current in excess of about 12 mA is to be used, the circuit shown in Fig. 5.19 is not suitable, although it is always possible to use a small relay which can be operated by the E90CC to switch on a larger relay or a counter.

An alternative is to use a valve which can supply more current to the relay or counter. Such a circuit is shown in Fig. 5.21 in which an EL84 is used to provide the power. The input pulses for this circuit may be taken from the junction of the resistors R_{36} , R_{37} and R_{39} in Fig. 5.13.

V1 of Fig. 5.21 is a monostable circuit. Normally V1a is cut off and V1b is conducting. A positive going input pulse causes V1a to conduct and the resulting negative pulse at the anode of this tube is used to cut off V1b. A positive pulse appears at the anode of V1b and this is fed through the 90C1 tube to the grid of V3. The output tube, V3, is normally biased to cut off, however, but conducts when each pulse is fed to it and thus operates the counter.

Table 5.1 THE EIT — ABRIDGED DATA

Heater

6.3 V at 0.3 A. Suitable for series or parallel operation.

Operating Conditions		Inter Electrode Capacitances	
* V_b	300 V	$C_{a_2\text{-all}}$	10.5 pF
* V_t	300 V	$C_{x'\text{-all}}$	3.5 pF
* V_{g_2}	300 V	$C_{x''\text{-all}}$	3.8 pF
* V_{g_1}	11.9 ± 0.15 V	$C_{g_1\text{-all}}$	6.8 pF
* $V_{x'}$	156 ± 1.5 V	$C_{g_4\text{-all}}$	7.7 pF
I_{g_2}	100 μ A		
I_k	900 μ A		
R_k	15 k $\Omega \pm 1\%$		
R_{a_1}	39 k $\Omega \pm 10\%$		
R_{a_2}	1.0 m $\Omega \pm 1\%$		
R_{g_4}	47 k $\Omega \pm 5\%$		

Base B12A Duodecal.

Connections see Fig. 5.3.

* All voltages are quoted with respect to the chassis. Provided that the ratios of these voltages are strictly maintained by using a suitable voltage divider consisting of 1% tolerance Grade 1 resistors, the supply need not be stabilised unless variations of more than $\pm 10\%$ are expected.

Operating Notes

The tube may be mounted in any position except horizontal with the fluorescent screen facing downwards.

External magnetic fields can influence the operation of the tube. The external flux density should not exceed 2 G (2×10^{-4} Wb/m²) in any direction.

It is advisable to use the tube in an ambient illumination of between 40 and 500 lux. If the illumination is low, it may be difficult to read the figures on the mask of the tube and occasionally some difficulty may be experienced by the neighbouring spots showing some fluorescence. If the ambient illumination is too great, some difficulty may be experienced in the observation of the luminous spot. It is advantageous to mount the tube a short distance behind the front panel so that the amount of light falling on the tube is reduced somewhat.

The length of time for which the relay is energised is determined by the time constant of the 1 M Ω resistor and 0.05 μ F capacitor in the grid circuit of V1b. The optimum pulse length depends on the type of counter used; the values shown are suitable for the P.O. 100 type counters which require a pulse of about 1/20 sec. If a fast counter is to be used, the value of the capacitor may be decreased to about 0.01 μ F.

A capacitor can be used instead of the 90C1 tube. The circuit takes quite a large current when the relay or counter is energised and if the same H.T. supply is used for the EIT circuits and for the circuit of Fig. 5.21, it is essential that it is stabilised. It is probably simpler to use separate H.T. supplies, since neither then need be stabilised. The electromagnetic counter should not be placed near to any EIT tube or the magnetic field may affect the operation of the tube.

5.21 REVERSE COUNTING

If suitable negative going pulses with a sharp leading edge and a long trailing edge are fed to the EIT, the tube will count in reverse⁽¹⁶⁾. Alternatively positive going pulses with a long leading edge and a trailing edge of high slope may be used. The resetting of the tube from zero to nine can be accomplished by employing a pulse generated at the g_4 electrode. If the tube is indicating the digit zero and a suitable negative going pulse is fed to the x' electrode, the electron beam will be deflected so that it no longer strikes g_4 . The reduction in the current passing through the g_4 series resistor enables a positive going pulse to be taken from this electrode. This pulse can be used to trigger a multivibrator which in turn provides a suitable negative pulse to the x'' deflector electrode so that the tube is reset to indicate the digit nine.

Other Scales

The EIT tube is essentially intended for scale of ten counting. It is, however, possible to employ a catching diode which conducts when the EIT anode reaches a certain positive potential during flyback so that the beam stops before it actually reaches zero⁽²⁾.

ELECTRONIC COUNTING CIRCUITS

REFERENCES

1. 'High speed decade counter tube, type E1T', *Mullard Technical Communications*, **2**, 13, 74 (1955).
2. R. E. NATHER, 'High speed counting with one-tube decades', *Electronics*, **27**, 174 (1954).
3. J. L. H. JONKER, 'Valves with a ribbon-shaped electron beam; contact valve; switch valve; selector valve; counting valve,' *Philips Res. Rep.*, **5**, 1, 6 (1950).
4. J. L. H. JONKER & Z. VAN GELDER, 'New electronic tubes employed as switches in communication engineering'. Part II switch tubes', *Philips Tech. Rev.*, **13**, 4, 82 (1951/1952).
5. 'The E1T decade counter tube'. *Electron. Appl. Bull.*, **14**, 1/2, 12 (1953).
6. 'Philips E1T Decade Counter Tube'. Philips Gloeilampenfabrieken (20/038/D/E-3-60).
7. 'Auxiliary circuits for decade counters' *Electron. Appl. Bull.*, **14**, 5, 76, (1953).
8. R. VAN HOUTEN, 'A decade counter stage with a counting rate of 100,000 pulses per second'. *Electron. Appl. Bull.* **15**, 3, 34 (1954)
9. 'Philips Decade Counting Units'. Philips Gloeilampenfabrieken, (32/320/D/E-8-61).
10. 'General Introduction to the 88929 Series of Counting Units' and 'High Speed Counters for Instrumentation', Mullard Equipment Ltd.
11. R. VAN HOUTEN & M. VAN TOL, 'Improving the resolving power of decade counters for random pulses'. *Electron. Appl. Bull.*, **15**, 12, 181 (1954).
12. R. KRETZMANN, *Industrial Electronics Circuits*, Philips Technical Library (1957).
13. R. VAN HOUTEN, 'Low-speed counter equipped with the E1T decade counter tube', *Electron. Appl. Bull.*, **15**, 6, 77 (1954).
14. A. DORN, 'A multi-decade predetermined counter', *Electron. Appl. Bull.* **14**, 6/7, 91 (1953).
15. R. KRETZMANN, *Industrial Electronics Handbook*, 3rd Ed., Philips Technical Library (1959).
16. P. PALIC & H. HERTWIG, 'Rückwärtszählung mit der E1T', Interner Applications labor-bericht der Valvo GmbH, Hamburg (1954).

Beam Switching Tubes

Beam switching tubes are high vacuum devices with heated cathodes which can be used to count at maximum frequencies of between 1 and 10 Mc/s. They may be classified into two main types which are known as 'Trochotrons' and 'Beam X' switching tubes. The trochotrons have a fairly large external magnet; they are manufactured by the Ericsson and Mullard Companies in Great Britain and by the Burroughs Corporation in the United States. The Beam X switching tubes have ten small rod shaped magnets inside the evacuated envelope which also serve as electrodes. Beam X tubes are smaller than trochotrons and not so susceptible to external magnetic fields. The name 'Beam X' is a registered trade mark of the Burroughs Corporation who manufacture these tubes. The basic principles of operation of trochotron and Beam X tubes are the same, but there are many constructional differences.

Although the disadvantage of the relatively long ionisation and deionisation times of gas filled tubes may be overcome by the use of high vacuum devices, the latter cannot be switched by the same mechanism as that used in polycathode gas filled tubes, since there are no critical values of striking and maintaining potentials and the absence of positively charged ions prevents any priming from taking place.

In beam switching tubes the electron beam rotates in a complete circle through ten stable positions when ten successive input pulses are applied to a tube. The switching process cannot therefore be accomplished by simple electrostatic deflection as in the other type of high vacuum tube, the EIT, in which the electron beam is merely deflected through an angle into ten successive stable positions and is

then reset. The necessity for resetting the EIT limits the maximum counting speed and complicates the circuitry. The EIT has the advantage over beam switching tubes that it is self indicating, whereas some form of external readout must be used when beam switching tubes are employed in counting circuits.

6.1 ELECTRON PATHS IN MUTUALLY PERPENDICULAR MAGNETIC AND ELECTRIC FIELDS

In order to understand the functioning of beam switching tubes it is first necessary to consider the paths which electrons take under the influence of perpendicular magnetic and electric fields. This should really be done by manipulation of differential equations^(1, 2), but the following simple description will suffice for a qualitative account of the functioning of beam switching tubes. The situation is, in any case, complicated by space charge effects.

In Fig. 6.1 a potential is applied between the two plates and a magnetic field is present with the magnetic intensity perpendicular to the plane of the paper. Lines joining points of equal potential (equipotential lines) have been drawn in the space between the plates. If an electron is placed at point *a* and its velocity is initially small, it will start to move under the influence of the electric field towards the positive electrode in a direction which is almost perpendicular to the equipotential lines.

As the electron accelerates towards the anode, however, it receives an additional force from the magnetic field. This additional force acts in a direction which is perpendicular to both the direction

ELECTRONIC COUNTING CIRCUITS

of the instantaneous motion of the electron and to the magnetic field. As the electron moves from *a*, the magnetic force therefore gives it an acceleration either to the left or to the right (depending on the polarity of the magnetic field) along an equipotential line. If the magnetic force tends to move the electron to the left, its path will curve away from the anode under the influence of the two forces as shown at *b*.

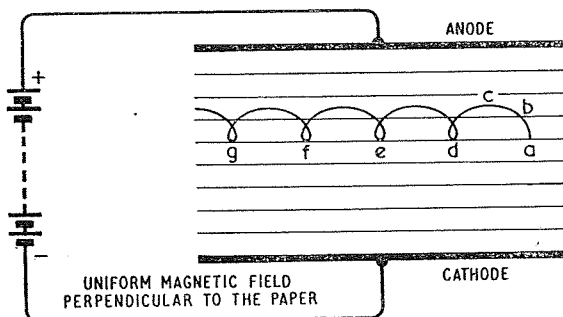

Fig. 6.1 The trochoidal path of an electron in perpendicular electric and magnetic fields

The electrostatic force is constant, but the magnetic force increases with the velocity of the electron. When the electron is moving parallel to the equipotential lines (as at *c*), the magnetic force will be acting towards the cathode, since it always acts in a direction at right angles to the path of the electron. The latter therefore moves towards *d*.

As the electron approaches *d* its velocity is almost in the opposite direction to the velocity it had immediately after leaving *a*. The electrostatic field is now opposing the motion and the electron slows down until momentarily the component of its velocity in the direction of the electric field becomes zero (at *d*). During the time the electron is moving away from the anode the force on it due to the magnetic field tends to accelerate it towards the right-hand side of Fig. 6.1 and this reduces the component of its velocity along the equipotential lines to zero at point *d*. The electron is accelerated from *d* by the electric field and completes further similar loops *de*, *ef* and *fg*. The magnitude of each step is determined by the relative magnitudes of the electric and magnetic fields.

It can be shown mathematically that the curve shown in Fig. 6.1 which the electron follows is a

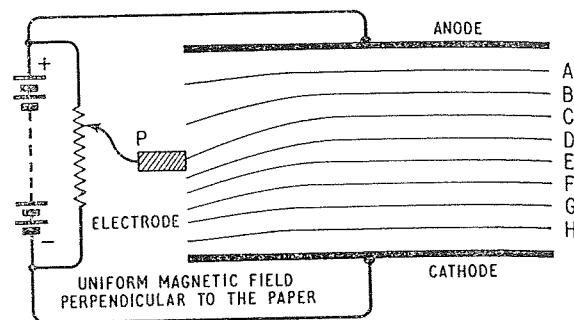

Fig. 6.2 The distortion of equipotential lines in the region of an electrode

trochoid, but the important point is that the electron beam, as a whole, 'drifts' along the equipotential line from *a* to *g*. Under the influence of the electric field along the electron beam would move in a direction perpendicular to the equipotential lines. The effect of the magnetic field is, therefore, to alter the direction of the beam by 90° .

If the magnetic field intensity is small relative to the electric field intensity, the electron beam will commence to move in a trochoidal path, but the magnetic field may be too small to prevent the electrons from reaching the anode. There is a value of magnetic field strength which is just large enough to prevent electrons from reaching the anode and in this case the point *c* of Fig. 6.1 will be at the surface of the anode.

If an additional electrode, the plate *P*, is placed in the system as shown in Fig. 6.2, the equipotential lines will be deflected in a way which depends on the potential of *P*. In the case shown in Fig. 6.2, *P* has the same potential as that of the equipotential line marked *C*.

It has been shown that the electrons travel along equipotential lines in the systems being discussed. If therefore a source of low energy electrons (such as a heated cathode) is placed successively on various equipotential lines (which necessitates the source having the same potential as the line on which it is placed), a large number of electrons will reach *P* only if the electron source is situated on or very near to the line *C*. If the electron source is placed on any other equipotential line, the electrons will travel along the line and the majority of them will pass above or below *P*.

Similarly if the electron source is placed on the line C and the potential of P is varied by means of the variable resistor shown, the number of electrons reaching P will be a maximum when the source has such a potential that it lies on the equipotential line C . If the electrode does not have this potential, the distortion of the equipotential lines will be different from that shown; P will therefore no longer be situated on the line C so that electrons passing along this line will not strike P .

The current/voltage characteristic curve for the electrode P shows a single maximum at the potential of the line C , the current falling off steadily on each side of this maximum. The curve thus shows a negative resistance effect on the one side. The so-called spade electrodes of beam switching tubes have a characteristic similar to that of P ; the importance of this will be seen shortly.

6.2 TROCHOTRONS

Tubes operating on the trochotron principle were first described in 1947 by H. Alfvén^(3, 4) who derived the name trochotron from the trochoidal path of the electrons in the mutually perpendicular electric and magnetic fields used in these devices. In some ways the trochotron resembles the magnetron valve in which similar perpendicular fields are used.

6.2.1 Construction

Several different basic designs of trochotron tubes are possible; for example, the linear or plane trochotron, the binary trochotron and the cylindrical trochotron. Trochotrons with two dimensional electrode structures have also been described⁽³⁾. This discussion will be limited to the cylindrical type, since the others are not generally available.

The shape of a typical trochotron, the Ericsson VS10G, can be seen in Plate 11, the magnet being cemented around the tube as shown. The dome is merely a cap which protects the vacuum seal. A cross sectional diagram of a typical Ericsson trochotron is shown in Fig. 6.3. The shape of the electrodes varies somewhat according to the type of tube; in particular, the Mullard and Burroughs tubes have rod shaped switching grids.

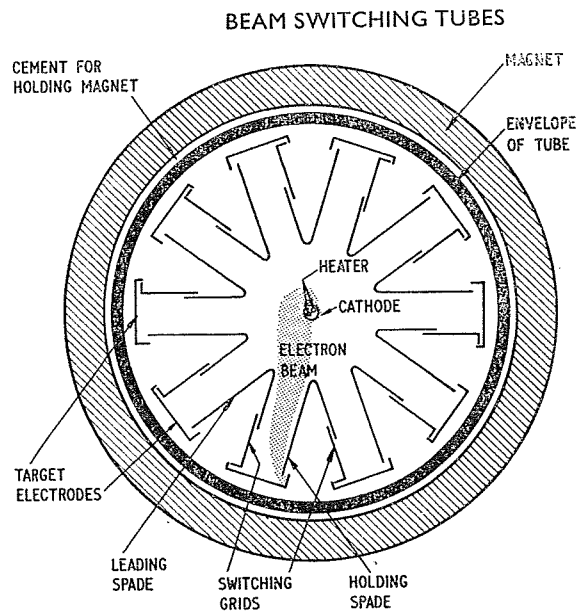

Fig. 6.3 A typical trochotron tube seen in cross section

It can be seen from Fig. 6.3 that there are four different types of electrode in the tube. In the centre there is a cylindrical oxide coated cathode which is indirectly heated. Thirty electrodes are placed around this cathode as shown so that the tube as a whole is symmetrical. Ten of these electrodes are main anodes or target electrodes; they collect most of the electron beam and are used as output electrodes in most applications. The ten spade electrodes enable the beam to be formed and to be stabilised at any desired target electrode. The remaining ten electrodes are known as switching grids and are used to produce the distortion of the electric field in the tube which causes the switching action to occur. The five evenly numbered switching grids are connected to a common base pin and the five odd switching grids are also connected together. These two sets of grids are usually shown on the left-hand side of the circuit symbol (Fig. 6.4) for the tube, since the input is fed to them.

6.2.2 Operation

The basic circuit for the operation of a trochotron is shown in Fig. 6.4⁽⁵⁾. The same positive potential is initially applied to all of the target and spade electrodes whilst the switching grids are held at about

ELECTRONIC COUNTING CIRCUITS

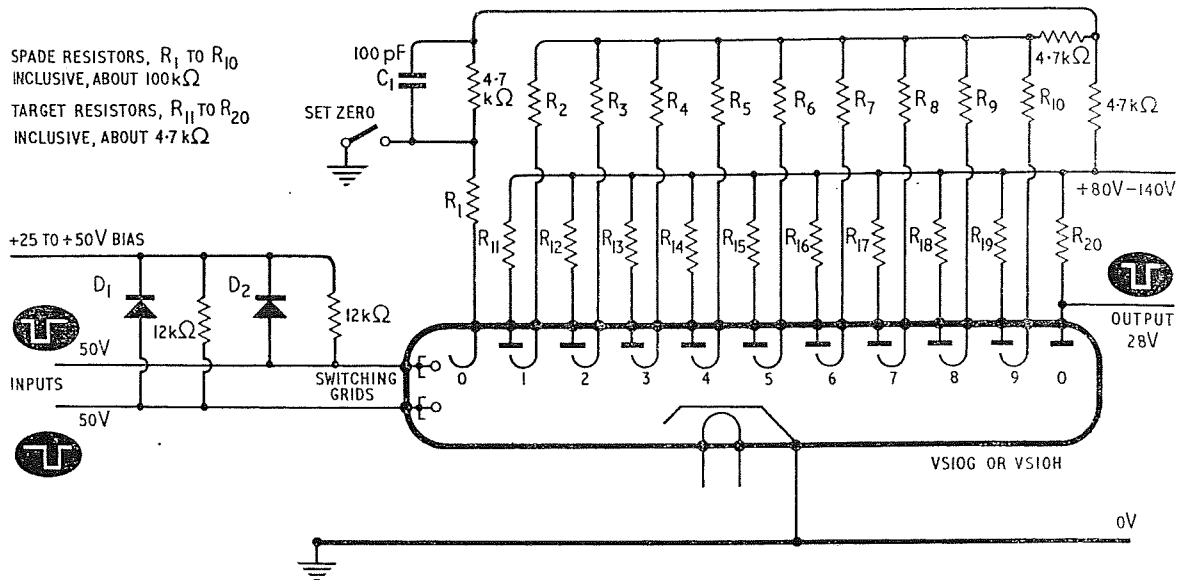

Fig. 6.4 The basic trochotron circuit with typical component values

half this voltage. The uniform magnetic field (normally some 200 to 500 Oersteds) is large enough to prevent electrons from reaching any of the electrodes surrounding the cathode when the normal working potentials are applied to the tube. The electric field is symmetrical and therefore the equipotential lines are concentric circles around the cathode. Electrons which leave the cathode will rotate around it following one of the equipotential lines. They form a space charge or virtual cathode. This is the cut off condition of the tube.

If the 'set zero' switch is closed momentarily, the potential of the zero spade will fall to that of the cathode, thus distorting the electric field. It is now possible for the electron beam to leave the cathode and travel along an equipotential line to the zero spade. Once the beam is within the enclosure formed by two spades, one switching grid and one target, the effect of the electric field becomes more important than that of the magnetic field and about 90% of the electrons pass to the target (which, of course, has a positive potential) as shown in Fig. 6.3. The remaining 10% pass to the spade electrode. Only a small fraction of the maximum possible cathode current is used to form the electron beam.

When the "set zero" switch opens again, the spade current will flow through the spade resistor.

The voltage drop across this resistor results in the potential of the spade being held at a value which is not very different from that of the cathode and therefore the electrons can continue to flow along the equipotential line from the region of the cathode to the spade. Thus the beam is effectively locked at the zero position until the distortion of the electric field is altered by changing the switching grid potential.

6.2.3 Spade Characteristics

The action of the spade potentials can be studied more thoroughly by means of the characteristic curves. Curve I of Fig. 6.5 shows a typical spade current/spade voltage static characteristic for the holding spade⁽⁵⁾ (the holding spade is the spade which is conducting). The potentials of the non-conducting spades, the targets and the switching grids are all held at a constant potential (often +100 V) relative to the cathode of the tube whilst the curve is being plotted. The peak of curve I occurs at about 2-3 mA for a typical trochotron. It should be noted that it occurs when the spade has a potential of approximately zero volts with respect to the cathode. At this potential the electrons can flow to the spade along the equipotential line in the

same way that they could flow to the electrode *P* in Fig. 6.2.

A typical load line, *abc*, intersects curve I at three points. At point *a* the current is zero and the spade concerned has ceased to conduct. At point *b* the slope is negative. If the current taken by the spade should increase very slightly, the spade potential will decrease (owing to the voltage drop in the spade resistor) and this will cause a further increase of spade current which results in a cumulative effect. Similarly if the spade current decreases slightly, a cumulative effect will occur in the opposite direction. Thus the point *b* is unstable. Point *c* is the normal operating point of the conducting spade and is stabilised by feedback; if the spade current increases slightly in the region of point *c*, the spade potential will decrease and this tends to counteract the increase of spade current.

The upper dotted load line of Fig. 6.5 represents the minimum value of spade load resistor which should normally be employed. If a smaller value is used, the load line will be steeper and will no longer cut the characteristic at points such as *b* and *c*. The only stable operating point will therefore be at *a* where the spade current is zero.

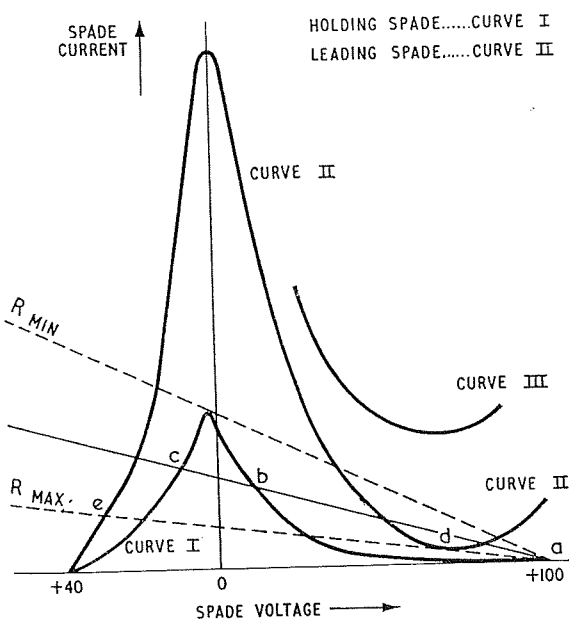

Fig. 6.5 Spade characteristics.

Curve II of Fig. 6.5 is the dynamic or leading spade characteristic curve. It is obtained by maintaining one spade (the holding spade) at the cathode potential and plotting the current/voltage curve for the succeeding spade whilst the targets, the switching grids and the other spades are kept at a constant potential (often +100 V) with respect to the cathode. The spade succeeding the holding spade is known as the leading spade. When the tube is switched, the leading spade becomes the holding spade and the characteristic of curve II is transformed into curve I at a rate which depends on the value of the spade load resistors and the stray capacity in the spade circuits.

The lower dotted line of Fig. 6.5 represents the maximum value of the spade load resistor which should be used. It is a tangent to the dynamic spade characteristic at point *d*. If a value of spade load resistor greater than that corresponding to the lower dotted line is employed, the load line would always intersect the leading spade characteristic at only one point, *e*, which will result in a continuous rotation of the beam.

The shape of the curves are altered somewhat by variations of the spade potentials. The maximum and minimum values of the spade resistors are therefore also functions of the spade supply voltage. If the supply voltage to the spades is steadily reduced, a point will be reached at which the beam will be extinguished. The extinguishing voltage, however, depends somewhat on the values of the spade resistors.

The holding spade potential may be negative with respect to the cathode by up to about 20 V⁽⁶⁾. Thus the electrons are flowing against the electric field and must be giving up energy to the field. Currents of this type are known as 'N' (negative) currents. They arise from an interchange of energy between the electrons as a result of oscillations in the trochoidal beam^(1,2). Electrons which gain energy reach the spade electrode in spite of the small opposing electric field. These electrons flow through the spade resistor and maintain its potential at a negative value with respect to the cathode. The holding spade voltage is dependent on the spade supply voltage and the value of the spade resistor employed.

6.2. Switching Grids

The switching grids are normally held at their quiescent positive bias potential. If the potential of the switching grids is lowered, the position of the equipotential lines in the region of the cathode is not appreciably affected owing to the screening effect of the spade electrodes. If the electron beam is passing to one of the target electrodes, however, the reduction of the potential of the associated switching grid will cause the equipotential lines to move across towards the grid so that the leading spade receives some of the beam current. The flow of current through the leading spade resistor lowers the potential of this spade which causes the equipotential lines to move further in a clockwise direction (in Fig. 6.3) so that the leading spade receives more current and falls further in potential. A cumulative action thus takes place which results in a rapid movement of the electron beam so that the leading spade momentarily takes the whole of the beam current. The magnetic field causes the beam to rotate to the side of the spade which is nearest to the target which is about to conduct. The spade potential falls and most of the beam passes to the target. The counting operation has now been completed.

It should be noted that this action can only be initiated by a lowering of the switching grid potential when the beam has already been formed at one target. Only the switching grid which is nearest the target at which the beam is resting produces any effect, since the other switching grids are screened from the electron beam by the spade electrodes.

If the potential of all the switching grids were lowered simultaneously, the beam would switch to its next stable position and would then continue to switch from target to target until the input pulse at the grids terminated. The frequency of rotation of the beam would be determined by the values of the resistors used in the spade circuits and by the stray capacitances. In order to prevent continuous switching, the switching grids are usually connected alternately in two groups of five. When a negative pulse is applied to one set of switching grids, the beam will move into the succeeding position but will not move any further, since the next switching grid is connected to the other set of guides and is

not therefore receiving a negative pulse. The input switching pulses are applied alternately to the two sets of guides from a valve or transistor bistable circuit. Other methods of driving trochotrons will also be discussed.

The direction of rotation of the electron beam is determined by the polarity of the magnetic field and by the fact that the tube geometry is not symmetrical in each direction. The beam can move only in a clockwise direction in the trochotron of Fig. 6.3, the switching grids pulling the beam off the target towards the leading spade.

It is instructive to consider the effect of the switching grid potential on the shape of the leading spade characteristic (curve II in Fig. 6.5). If the potential of the switching grid is reduced, the tail of the leading spade characteristic is raised to a position such as that of curve III of Fig. 6.5. The load lines now cut the leading spade characteristic only at negative spade voltages. As the operating point moves towards a negative spade potential the tube is switched, therefore, to the next stable position.

The degree of lift of the tail of the leading spade characteristic for a certain negative switching grid pulse is a measure of the reliability of the switching process in the tube concerned and is determined mainly by the geometry of the switching electrodes. These electrodes may consist of flat plates or of small diameter rods. The flat plate type of switching grid (as used in Ericsson tubes and as shown in Fig. 6.3) has the advantage that it can produce a much greater lift of the tail of the leading spade characteristic and therefore an improved switching action⁽²⁾, but it suffers from the disadvantage that it draws a current of a few hundred microamps during the switching operation. In addition, five of the plate type of switching grids connected in parallel have an input capacitance of about 25 pF and therefore a low impedance circuit must be used to drive this type of tube at high frequencies. The rod type of switching grid (such as used in the Mullard ET51 and in the Burroughs tubes) takes an almost negligible current and has a much smaller input capacity (five grids in parallel have a capacity of about 9 pF to earth); higher impedance drive circuits may therefore be used.

The quiescent switching grid potential or bias which is required is proportional to the spade supply voltage used. If the switching grids receive a positive bias which is too large, the input pulses which are used to overcome this bias and cause switching must be of larger amplitude. On the other hand if the bias is too low, the trochotron may switch automatically without any input pulses being applied. The flat plate type of switching grids requires a bias equal to about half the spade supply voltage, whilst the bias required for the rod type of switching grid is about one quarter of the spade supply voltage. Suitable switching grid bias voltages and input pulse voltages for the operation of various types of beam switching tubes are shown in Table 6.1.

The diodes D_1 and D_2 in Fig. 6.4 are used to clamp the switching grid voltage to the bias level; that is, they prevent the grids from becoming more positive than the potential of the bias supply.

6.2.5 Target Characteristics

The potential of the target electrodes has little effect on the beam current owing to the screening effect of the spade and switching grid electrodes. The target current/target voltage characteristic is therefore very similar to that of the anode current/anode voltage characteristic of a pentode valve. A prominent 'knee' is present in the target characteristic at a target voltage of approximately half the spade supply voltage⁽⁶⁾. At target voltages above this knee the targets can be used as output sources of constant current; trochotrons are therefore ideal devices for driving numerical indicator tubes. The target loads should be chosen so that the targets do not operate below the knee of the characteristic, since the switching action of the tube is affected if the target current is not independent of the target voltage.

The magnitude of the target current is determined by the spade potential. The tube manufacturers normally attempt to obtain the maximum possible target current for a given spade voltage. At counting speeds greater than about 200 kc/s the target current will tend to decrease⁽⁶⁾, since after each switching operation the holding spade voltage has to rise to the spade supply potential and this takes

a short time. The effect is the same as if the spade supply voltage had been reduced. The drop in output current at 2 Mc/s is about 40% of the output current at low speeds. This fall in output can be reduced by using suitable circuits, for example the spade resistors may be returned to the corresponding targets instead of to the common voltage supply line. A lower value of spade resistor can then be used and this reduces the spade recovery time constant.

The maximum output voltage from a target is limited by the maximum permissible voltage across the tube and by the fact that the target voltage should not be allowed to fall below the knee of the characteristic (which is approximately half the spade supply voltage). The maximum pulse output voltage is thus equal to the maximum permissible target to cathode voltage minus half the spade voltage.

If the output pulse voltage from a target exceeds about 75 V, it is necessary to consider the effect of internal feedback via the inter-electrode capacities of the tube, since this may impair reliability. If the tube will not be required to operate at very high speeds, this feedback may be reduced by means of small capacitors (about 10 pF) connected across the spade resistors.

The target current will not be exactly the same at each position owing to small variations in the magnetic field strength and to small geometrical differences in the electrodes at various positions. This effect can be reduced by the use of a cathode resistor to raise the cathode potential to between 50 and 75 V above earth⁽²⁾. The resistor should be by-passed by a capacitor of about 1,000 pF. The use of a cathode resistor enables circuits with directly coupled inputs to be designed more easily.

If an output pulse is required from only one target (e.g. for triggering the next decade), the other targets may be joined together and fed from a single resistor. Any target from which a separate output pulse is to be taken must have a separate resistor.

6.2.6 Leakage Currents

When the trochotron is cut off (that is, when the beam has not been formed in any position), the

ELECTRONIC COUNTING CIRCUITS

magnetic field should, in an ideal tube, ensure that no current passes to any of the spades or other electrodes. In actual tubes there are small leakage currents of the order of $5 \mu\text{A}$ per spade due to the following three factors. In a rotating space charge some of the electrons will gain sufficient energy from other electrons to enable them to reach the spade electrodes. In addition, further leakage currents arise from the slight non-uniformity of the magnetic field and from leakage across the external and internal connections to the tube.

The leakage current must not be large enough to cause an appreciable change in the spade potential when it flows through the spade resistor. The current tends to increase somewhat during life as the magnet ages, but if the magnet comes into contact with any magnetic materials, a large increase of the leakage current may occur and the performance of the tube may be impaired.

6.2.7 Maximum Speed of Operation

The British trochotron tubes which are commercially available have a nominal maximum continuous operating speed of 1 or 2 Mc/s. The Burroughs MO-10R tube and its magnetically shielded version, the BD309, will operate at frequencies up to 10 Mc/s; the spade resistors of these particular tubes, however, are included inside the evacuated envelope in order to reduce the stray capacities to a minimum.

It has been shown⁽²⁾ that a trochotron with a maximum continuous counting speed of 2 Mc/s has a typical resolving time of about $0.16 \mu\text{sec}$ when up to nine pulses are to be counted. The maximum continuous operating speed is, however, determined by the time taken by the spade electrodes to reach their quiescent potential after a switching operation. Calculations show that a maximum continuous operating speed of about 3.7×10^6 pulses per second may be expected⁽²⁾. Speeds of about this value are obtained when the switching grids are all connected to the cathode and the electron beam is allowed to rotate freely, but in actual counting circuits a lower limit is imposed on the maximum continuous counting speed so that there is no possibility of the beam being extinguished.

6.2.8 Reset

If the beam is formed at any target and it is desired to reset the trochotron, the tube must first be returned to the cut off condition. The beam may then be reformed at the zero target or at any other desired target. The 'set zero' switch of Fig. 6.4 can be used to carry out both of these operations. When this switch is closed, the spade potentials are all momentarily reduced to the cathode potential (owing to the effect of C_1) and the beam is cut off. As C_1 charges, the potentials of spades one to nine inclusive increase to about half the supply voltage. The zero spade remains at the cathode potential and the beam therefore forms at this electrode. When the set zero switch is released, spades one to nine return to the H.T. supply potential immediately, but the capacitor C_1 delays the rise of the potential of the zero spade and ensures that the electron beam remains in the zero position.

If the trochotron is fed from a bistable circuit, the latter must be reset before the trochotron beam is formed in the zero position, or the tube may switch to position one.

6.2.9 Practical Precautions

Magnetically shielded versions of some types of trochotron tubes are available (see table of tube data). These shielded versions are of larger diameter, somewhat more expensive and about three times heavier than the unshielded tubes, but they have the advantage that they can be used in magnetic fields and in close proximity to magnetic materials (including other trochotron tubes). The shielding is achieved by the use of a mu-metal screen and a tapered magnet. The following precautions concerned with the operation of trochotron tubes in magnetic fields or near to magnetic material apply only to unshielded tubes.

A magnetic field strength of less than about 25 Oersteds will generally cause a negligible effect on the operation of a trochotron, whilst field strengths from about 25 to 50 Oersteds will cause changes in the tube currents without impairing the functioning of the tube⁽⁶⁾. Field strengths above about 50 Oersteds will probably affect the operation of the tube.

Care should be taken that the magnet of a trochotron tube does not receive any mechanical shock and that no magnetic material comes into contact with it. Unshielded tubes should not be mounted within 2 in. of any magnetic material or within 4 in. of another trochotron, a magnet or a mu-metal screen.

If the tubes are placed end to end, they may be spaced somewhat closer than the recommended 4 in. When placed end to end with the magnetic fields of the two tubes assisting each other, the magnets should be separated by a distance of at least 3 in. Generally, however, it is more convenient to place them end to end with their magnetic fields opposing each other, since the base connections of the two tubes are then at opposite ends of the combination. In this case the separation between the magnets may be as low as 2 in.⁽⁶⁾ which results in a separation of about $\frac{1}{4}$ in. between the domes of the tubes.

Trochotrons may be mounted through a steel panel or chassis provided that they are inserted in holes which are not less than $2\frac{1}{8}$ in. in diameter and provided that they are placed in the hole so that the steel panel is within $\frac{1}{4}$ in. of the centre of the tube magnet⁽⁶⁾.

The spade resistors should be soldered as closely as possible to the base of the tube so that stray capacities are reduced to a minimum. If the stray spade capacities are appreciably increased by poor circuit layout, the maximum operating frequency will be reduced. Care should also be taken that the values of the spade resistors and of the spade supply voltage are suitably chosen or the tube may either oscillate or not switch at all.

6.3 TROCHOTRON CIRCUITS

6.3.1 Drive Circuits

There are three basic ways in which the input voltages required for the operation of trochotron tubes may be obtained. If the input is a sine wave, the type of circuit shown in Fig. 6.6 may be employed^(2, 6). It has the advantage of being very simple, but the switching rate is twice the input frequency

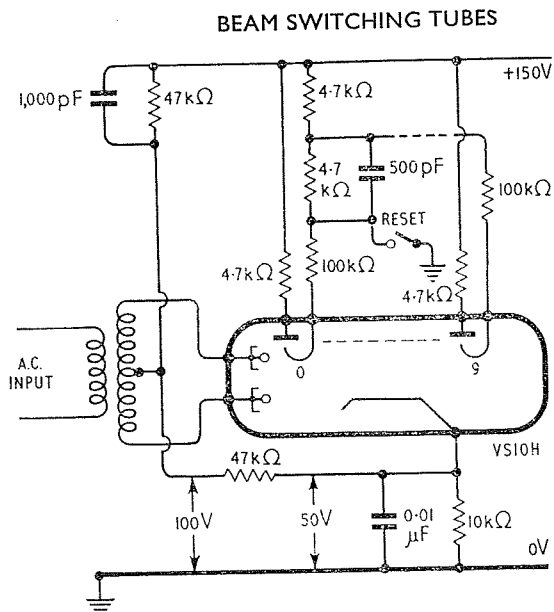

Fig. 6.6 A sine wave input circuit for a trochotron

since both the positive and negative peaks of the sine waves are counted. The output of the centre tapped secondary winding of the high frequency transformer is 50—0—50 V.

Another type of trochotron drive circuit is shown in Fig. 6.7^(2, 6). The two sets of switching grids are connected together and small capacitors (marked C) may be connected from each spade to earth so that the switching speed of the tube is deliberately reduced. The input pulses for the switching grids may be obtained from the blocking oscillator circuit shown. It is essential that the duration of the pulses to the switching grids be kept shorter than the switching time of the tube so that double switching on one input pulse cannot occur; the output from the blocking oscillator satisfies this condition. This type of circuit is known as discrete or single pulse drive. The potential divider resistors marked R_1 , R_2 and R_3 should be chosen so that their junctions have the potentials marked in the circuit diagram.

The most common type of trochotron input circuit employs a bistable multivibrator circuit, the two sets of switching grids of the trochotron being fed from the two anodes of the multivibrator. Each input pulse reverses the state of the bistable circuit so that the potential of one set of switching grids is lowered at the same time as the potential of the

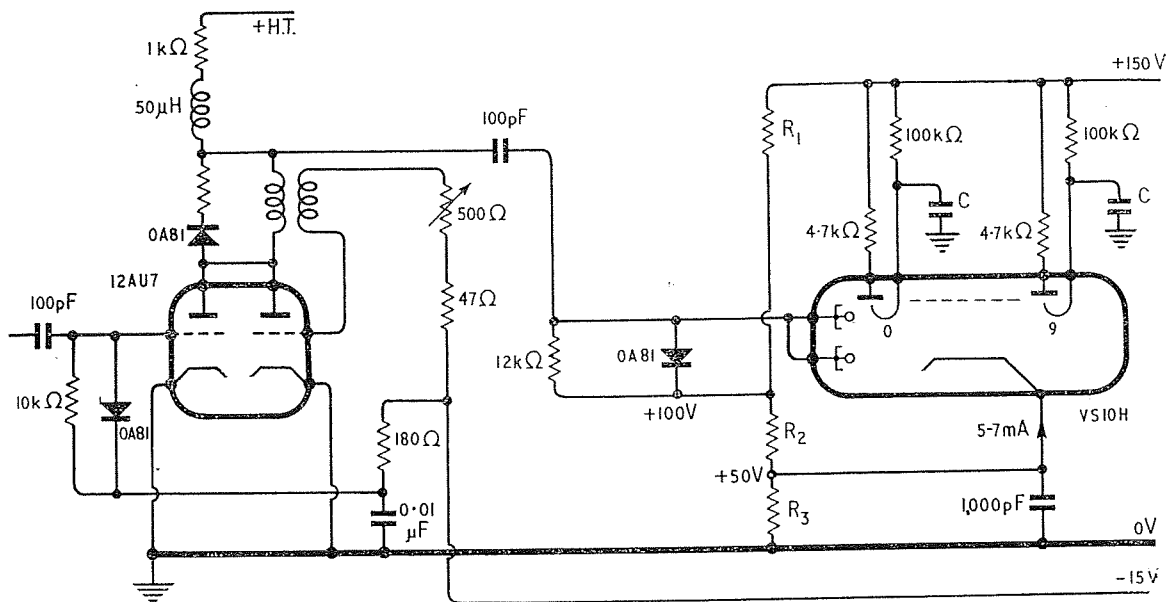

Fig. 6.7 A discrete pulse drive circuit for a trochotron

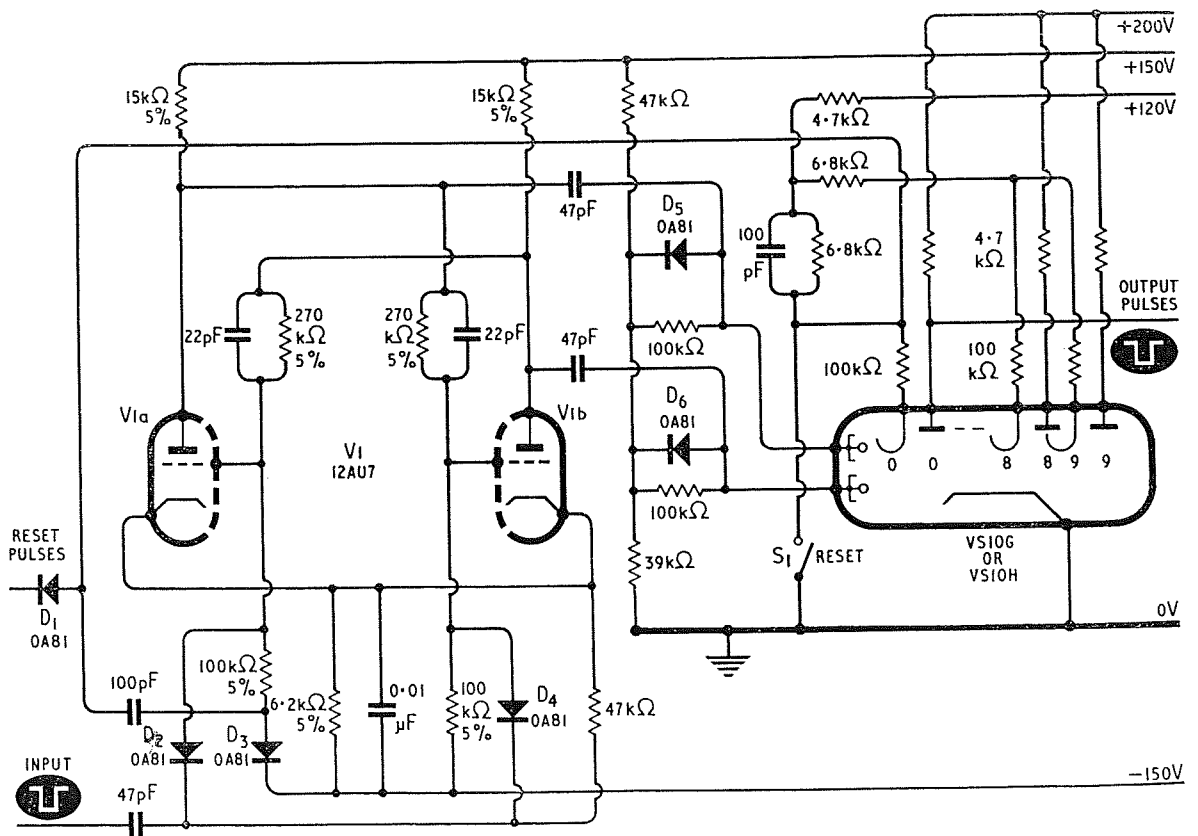

Fig. 6.8 A trochotron circuit for use at frequencies up to 200 kc/s

other set is raised. A circuit of this type which can operate at frequencies up to about 200 kc/s is shown in Fig. 6.8⁽⁷⁾.

The negative going input pulses to the multi-vibrator circuit of Fig. 6.8 should have a minimum amplitude of about 10 V and a minimum duration of about 2 μ sec. The negative going output pulses have an amplitude of about 35 V; if they are to be used to drive a second identical decade, the resistor in the zero target circuit may be replaced by a 3.3 k Ω and a 1.5 k Ω resistor placed in series, the 3.3 k Ω resistor being connected to the target. The output may then be taken from across the 1.5 k Ω resistor and will consist of the required pulses of about 10 V in amplitude for the operation of the next decade. The diodes D_2 and D_4 enable the input pulses to be fed to the valve grids whilst isolating the grids from each other. The diode D_3 normally returns the grid of $V1a$ to earth, but when a resetting pulse is received D_3 is cut off so that the pulse is fed to the grid of $V1a$. The bistable circuit is thus reset with the trochotron tube reset pulse. The diode D_1 prevents a negative pulse from the grid of $V1a$ from being fed into the bistable circuit of another decade where it would trigger the latter. The manually operated reset switch also resets both the trochotron and the bistable circuit.

If a trochotron which employs the flat plate type of switching grid is to be used at frequencies above about 200 kc/s, the grids of the tube should be fed from low impedance sources (such as power amplifier tubes or cathode followers) which can supply the current required by the switching grids, including that required to rapidly charge the switching grid capacitance.

Fig. 6.9 shows a circuit which can drive the VS10H at frequencies up to the maximum recommended for the tube, namely 2 Mc/s^(2, 8). The negative going input pulses should have an amplitude of not less than 15 V and a duration of not less than 0.25 μ sec. They are fed via two diodes to the grids of the bistable circuit, $V2$ and $V3$. The outputs from this circuit are fed into $V4$ and $V5$ which are EL821 power amplifier valves in a push-pull circuit. These tubes can provide ample current to feed the switching grids of the VS10H even at high operating speeds. The EB91 diode, $V6$, serves to

clamp the switching grid potential to that of the cathode of the GD90M voltage stabiliser tube.

The circuit of $V1$ in Fig. 6.9 enables the trochotron to be reset electronically. The positive going reset pulses of 50 V amplitude and not less than 1.5 μ sec duration are fed to the grids of $V1a$ and $V1b$. The output from the anode of $V1b$ is used to reset the bistable circuit ($V2$ and $V3$) and also to reset the trochotron by the same mechanism as that used in the circuit of Fig. 6.8. The output from the anode of $V1a$ can be used to reset a succeeding decade. A manual reset switch is also provided.

If the circuit is operating at its maximum frequency of 2 Mc/s, the output pulses will have a frequency of 200 kc/s and can be counted by the circuit of Fig. 6.8. The amplitude of the output pulses from the circuit of Fig. 6.9 is too large for feeding into the circuit of Fig. 6.8 directly, but a tapping may be made on the zero target resistor of the Fig. 6.9 circuit so that the desired fraction (about one eighth) of the output pulse may be obtained for feeding into the input stage of the next decade.

6.3.2 Readout

The target current of a trochotron may be used to operate a relay, a miniature neon diode in series with the target electrode, a transistor which switches on a lamp, etc., but normally readout is effected by means of a cold cathode indicator tube. The target current of a trochotron is almost independent of the target voltage provided that the tube is operated above the knee of the target characteristic; a trochotron is a very suitable device for driving a numerical indicator tube, since the operating voltage of the latter is substantially independent of the current over the working range.

A circuit for the operation of the GR10A indicator tube is shown in Fig. 6.10^(5, 9). This tube has the same type of display as the cold cathode counting tubes discussed in Chapter 4 and is therefore very useful when the trochotron circuit is followed by cold cathode decade tubes. The input circuit of Fig. 6.10 comprises a bistable circuit which is directly coupled via a cathode follower to the VS10G. The low impedance of the cathode follower provides enough switching grid current to drive

ELECTRONIC COUNTING CIRCUITS

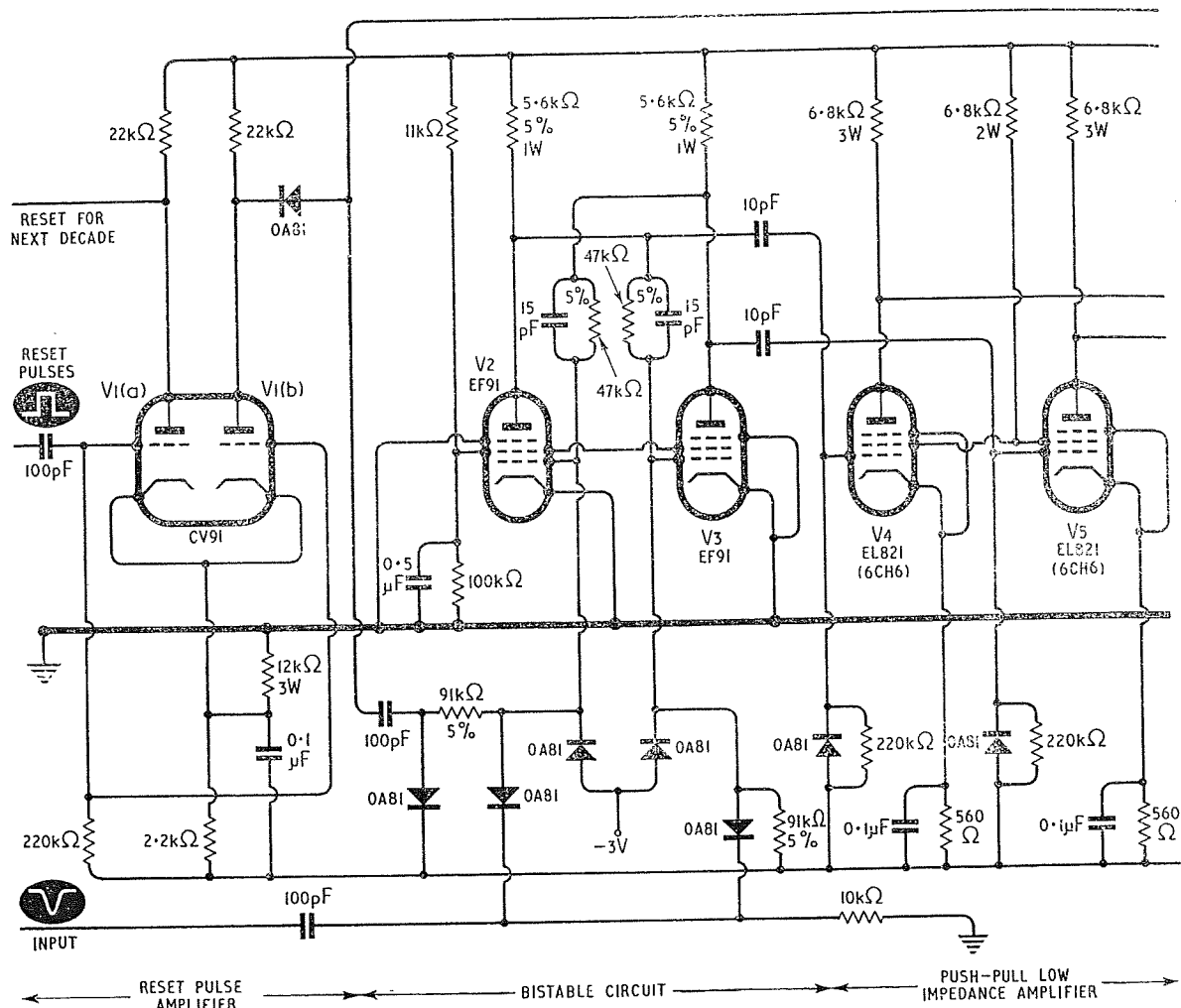

Fig. 6.9 A VS10H circuit for operation at up to

the trochotron at any frequency up to the maximum recommended for the tube (1 Mc/s). The current flowing through the cathode resistor enables a suitable value of the switching grid bias to be obtained and also stabilises the value of the trochotron cathode current. The input pulses to this circuit should have an amplitude of 30 V and a duration of not less than 0.2 μ sec.

In the circuit of Fig. 6.11(a), a VS10G trochotron is used to drive the Ericsson GR10G side viewing Digitron numerical indicator tube⁽¹⁰⁾, whilst in the circuit of Fig. 6.11(b) a VS10H tube is used to drive the GR10H end viewing Digitron⁽¹¹⁾. Any of the input circuits discussed previously may be used

with these circuits. The GR10H requires a smaller current than the GR10G.

In such circuits the Digitron is extinguished when the operating frequency of the trochotron exceeds about 200 kc/s, but as soon as the counting speed falls, the Digitron will indicate the correct count. In order to ensure that the trochotron operates on the constant current part of the target characteristic, the circuit must be arranged so that the target voltage never falls below half the spade supply voltage even if the Digitron current is zero during high speed counting. The targets must therefore be supplied with current from an H.T. line as well as from the Digitron. A potential of about 100 V is maintained

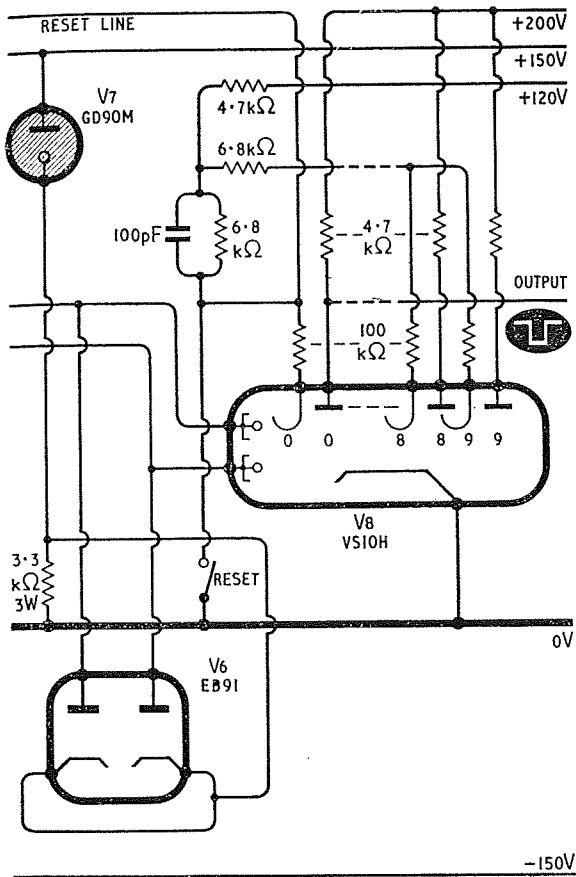

2 Mc/s with electronic and manual reset

permanently across the Digitron. The additional voltage drop in the target resistor which is conducting is sufficient to cause the appropriate Digitron cathode to conduct. The target current divides itself between the target resistor and the Digitron. The anode resistor of the Digitron may be omitted in some cases, but this may restrict the choice of circuit values.

The value of the target resistors required in circuits employing Digitrons and trochotrons (such as those of Fig. 6.11) may be calculated as follows. If:

- V_T = target supply voltage
- V_D = digitron anode supply voltage

- I_D = digitron current
- R_D = digitron anode resistance (if used)
- V_R = digitron maintaining voltage
- I_T = trochotron target current

$$\text{Target to cathode voltage} = V_T - (I_T - I_D)R_T = V_D - I_D R_D - V_R$$

$$\text{Hence } R_T = \frac{V_T - (V_D - V_R - I_D R_D)}{I_T - I_D}$$

It is also important that R_T should be less than $\frac{V_T - 0.5V_S}{I_T}$ where V_S is the spade supply voltage, or the trochotron target current will not be independent of the target voltage.

6.3.3 The VS10K

The VS10K trochotron is a low voltage tube with flat plate switching grids which has been designed for use with transistor drive circuits. The magnetic field strength is about half that used in the higher voltage tubes, and the target current is about 2 mA.

A typical VS10K circuit which can operate at frequencies up to about 1 to 1.5 Mc/s is shown in Fig. 6.12^(6, 12). This circuit operates from a 28 V supply. The input pulses (of about 10 V amplitude and 0.25 μsec duration) are fed to a bistable circuit employing 2N269A or ASZ20 transistors which drive the trochotron. If the left-hand transistor is conducting, the potential drop across its collector resistor will keep the base of the other (non-conducting) transistor relatively positive. Positive going input pulses will reach only the base of the conducting transistor, since the OA81 diodes in the input circuit prevent them from reaching the more positive base of the non-conducting transistor. The pulses from the output target are inverted in phase by a third 2N269A or ASZ20 transistor so that they are suitable for the operation of a similar succeeding decade. The reset switch will reset both the bistable circuit and the VS10K.

If some form of readout is required, an OC76 transistor may be used in any target circuit to switch on a small 6.3 V tungsten filament bulb as shown in the inset of Fig. 6.12. Alternatively, the trochotron

BEAM SWITCHING TUBES

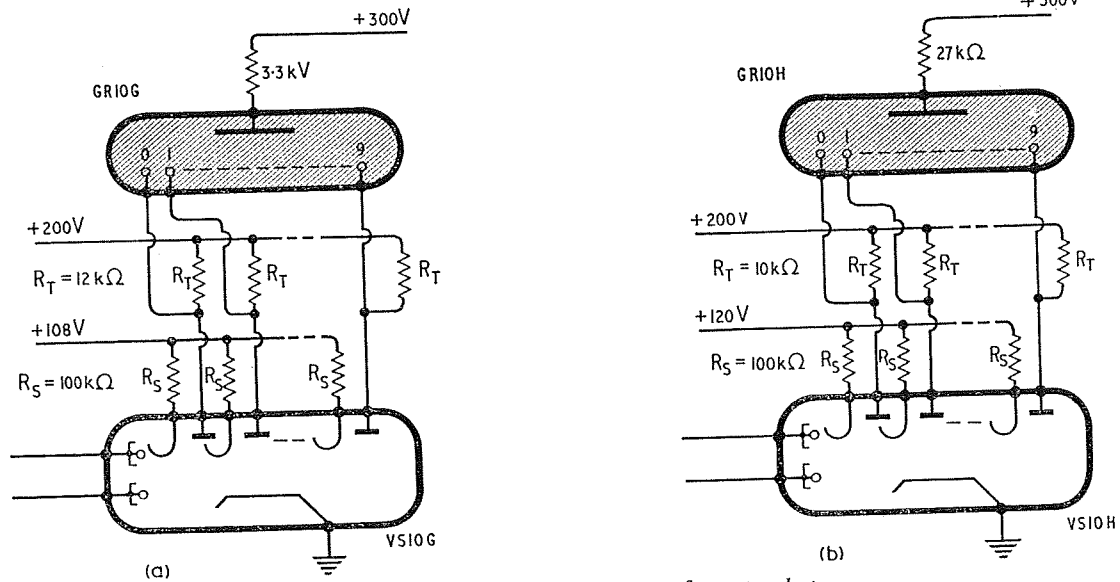

Fig. 6.11 The operation of Digitrons from trochotrons

may be used to control an OC76 transistor which operates a relay as shown. A diode is placed across the relay to remove inductive surges.

If a transistor driven VS10K circuit is required to operate a Digitron tube, a high voltage supply is essential. A typical circuit is shown in Fig. 6.13 in which two OC44 transistors are used in a bistable circuit to drive the VS10K at up to 200 kc/s⁽⁶⁾. The spade resistors are by-passed with 12 pF capacitors in order to reduce the interaction between the target pulses and the spade circuits. The beam may be formed by closing S_1 .

If Digitron readout is required from a trochotron circuit, one of the high voltage trochotron tubes is normally used as a high voltage supply is available.

6.3.4 Fast Electronic Resetting

The circuit of Fig. 6.14 can be used to rapidly reset a trochotron by means of a negative going resetting pulse of about 30 V in amplitude and 1 msec in duration⁽⁶⁾. Normally the cathodes of the 12AU7 tube and the trochotron have a potential of about +50 V with respect to earth, whilst the grid of the 12AU7 is maintained at about +20 V above earth. The 12AU7 is therefore cut off.

When the EL821 is cut off by the resetting pulse, the trochotron is also cut off. The common cathode

potential of the trochotron and the 12AU7 falls until the triode conducts. The zero spade is reduced to a low potential by the flow of the triode anode current through the spade resistor and this results in the beam being formed at the zero spade. The 12AU7 is then cut off again. The resistor values shown are suitable when a Digitron is employed, but they may be altered according to the circuit being used. If the trochotron cathode current is less than 8 mA, the other half of the 12AU7 may be used in place of the EL821.

6.3.5 Presetting

Outputs may be taken from one preselected target in each decade and fed into a coincidence circuit (somewhat similar to that of Fig. 3.20) so that an output pulse is obtained only at the preselected count. Alternatively the beam in each tube may be formed at any desired target. If the beams of a three decade scaler are preset to, say 628, an output pulse will be obtained after $1,000 - 628 = 372$ input pulses have been fed to the circuit.

6.3.6 Coupling to Dekatrons

It is often desirable to use a fast trochotron circuit to drive a succeeding slower (but more economical)

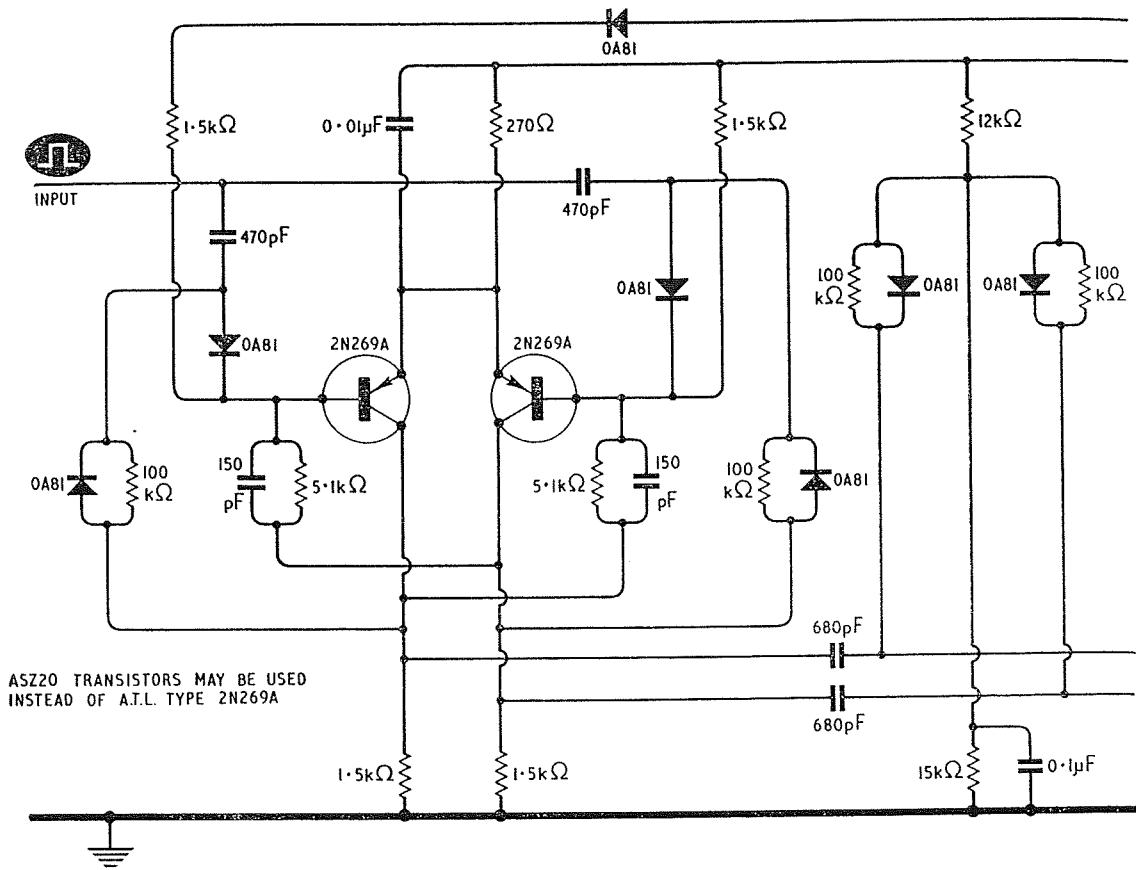
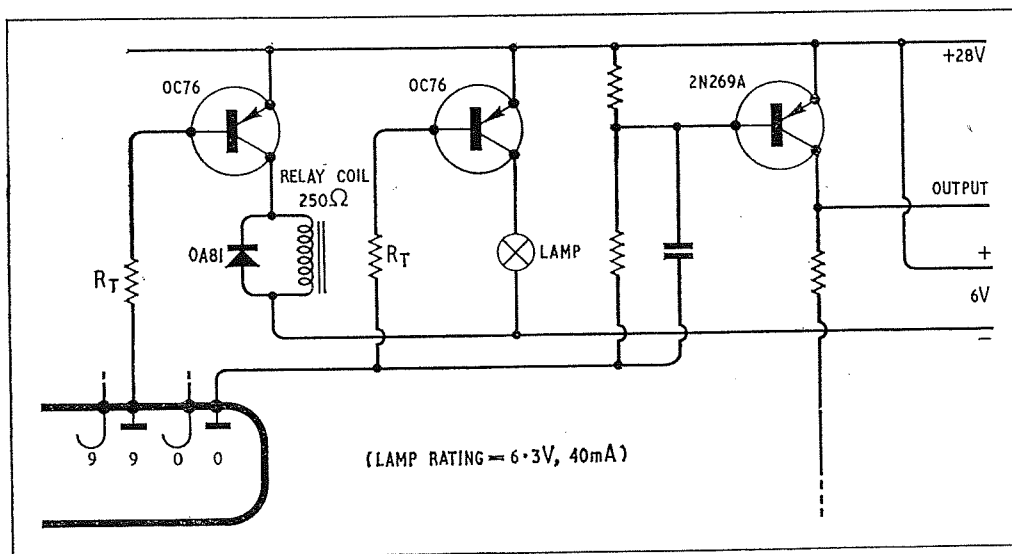
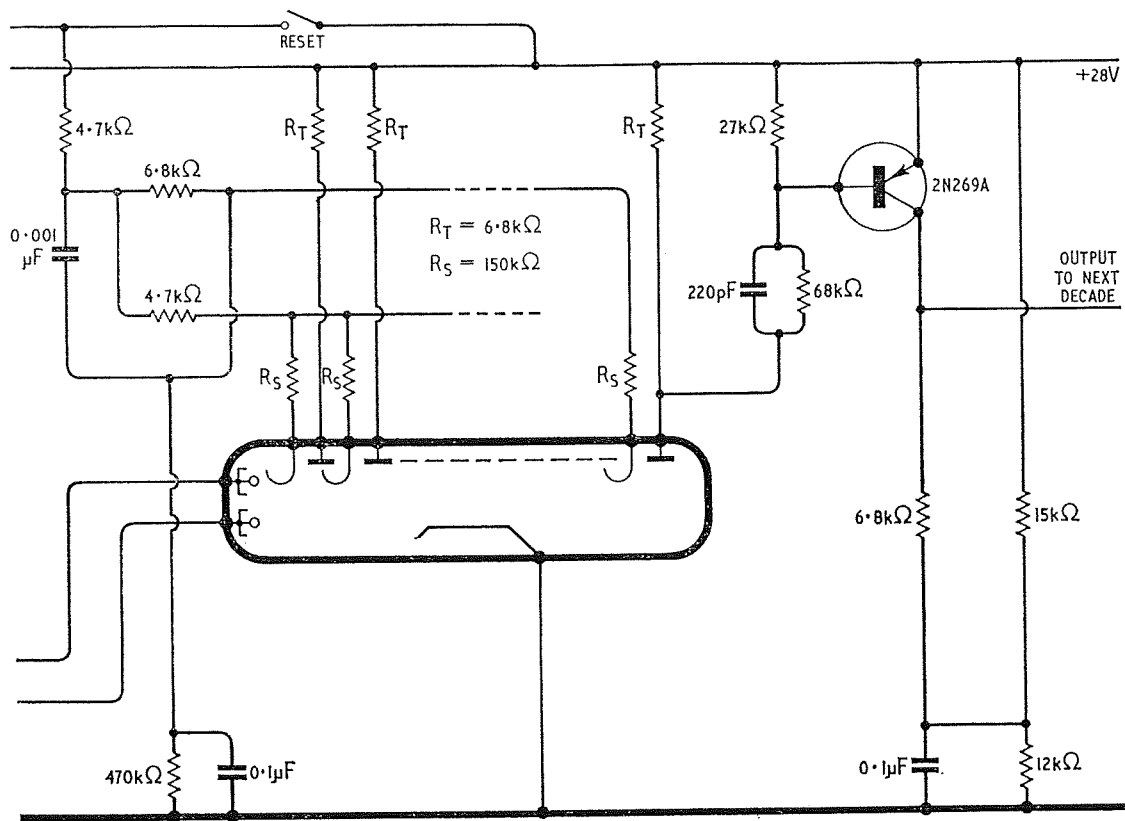

Fig. 6.12 A 1 Mc/s transistor circuit using the low voltage VS10K tube



ELECTRONIC COUNTING CIRCUITS

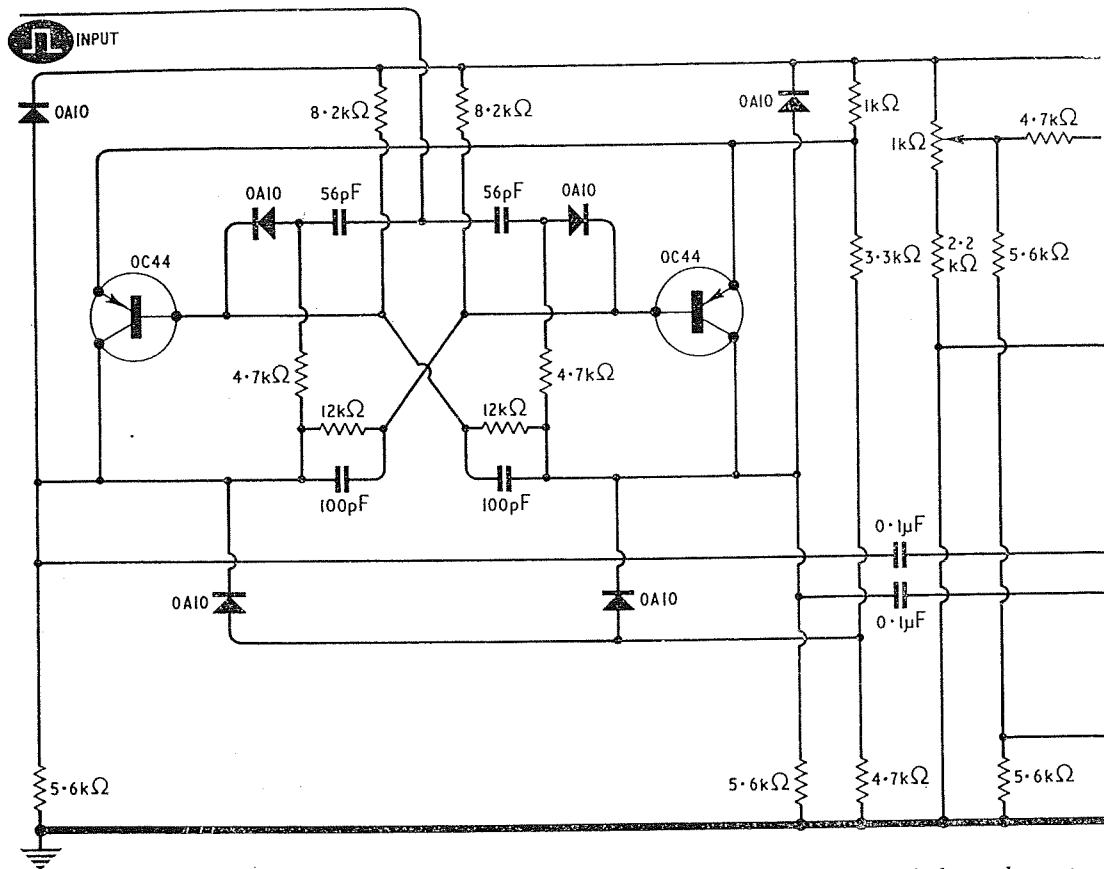

Fig. 6.13 A 200 kc/s low voltage trochotron

cold cathode decade tube circuit. The pulses from the trochotron output target will vary with the counting speed and will not in general be suitable for driving a cold cathode decade tube directly. The circuit of Fig. 6.15⁽⁶⁾ may be used to convert the output pulses from the trochotron into pulses of about 140 V in amplitude and of about 25 μsec duration which are suitable for driving a GC10D single pulse Dekatron. The value of the coupling capacitor (100 pF in the circuit shown) may be altered so as to provide pulses of a different duration which are suitable for operating other types of cold cathode decade tube.

Normally the right-hand triode is conducting whilst the left-hand triode is cut off by the bias developed across the common cathode resistor. The trochotron output pulse is coupled to the grid of the right-hand triode and cuts it off. The OA81 diode prevents the trailing edge of the pulse from the trochotron from causing the monostable circuit to return prematurely to its quiescent state.

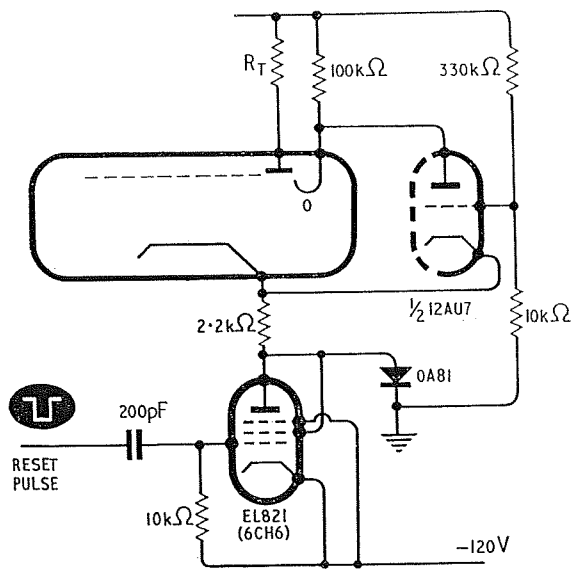
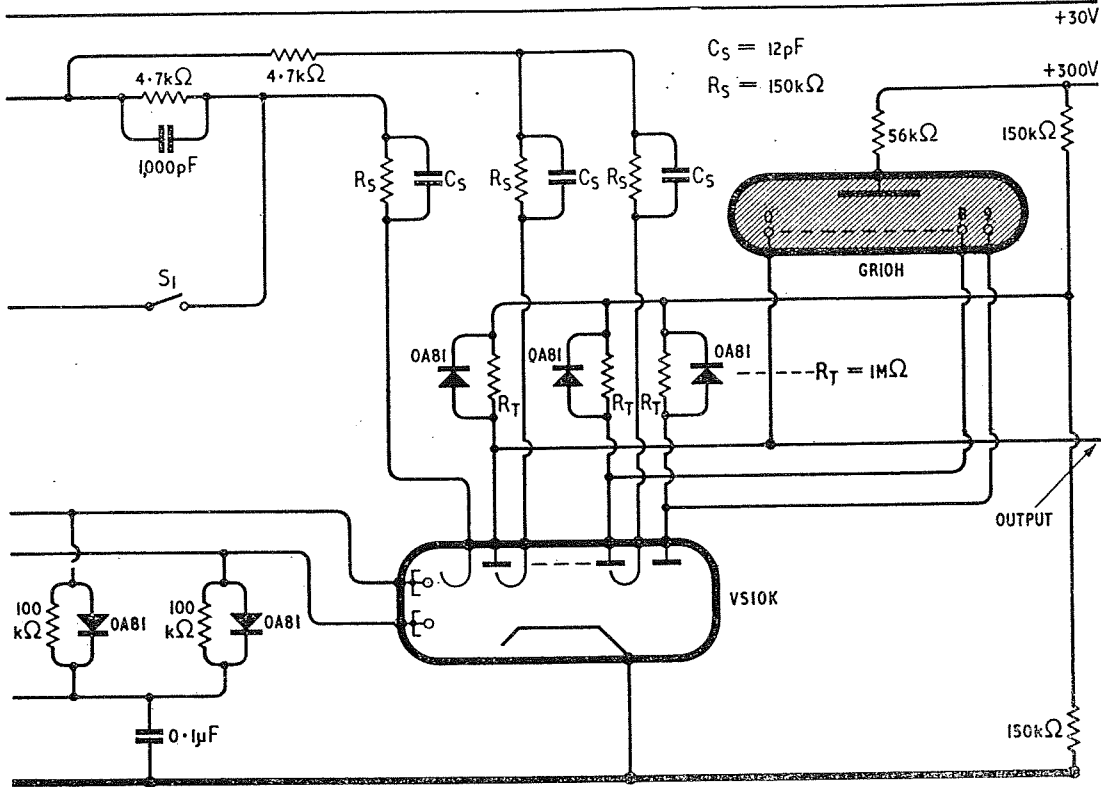

Fig. 6.14 An electronic resetting circuit



circuit with GR10H readout

6.3.7 Scaling Factors Other than Ten

Although basically intended for use as a decade tube, trochotrons can be used to divide the incoming pulses by various factors other than ten. For example, if targets 0 and 5 are joined together and all of the other targets are also joined, the circuit will divide the incoming pulses by five. The output is taken from the common connection to the targets 0 and 5. Similarly if alternate targets are connected together so as to give two separate groups of five targets per group, the circuit will divide by two⁽⁶⁾. Each group has its own target resistor.

If spade 4 is connected to spade 5, when the beam moves from spade 3 to spade 4, the potential of spades 4 and 5 will be lowered. Thus the beam will switch to position 5. Unless the input pulse is extremely short, the fifth switching grid will still be at a low potential, since it is connected to the odd grids. The beam will therefore move to position 6. Thus a scale of eight has been formed.

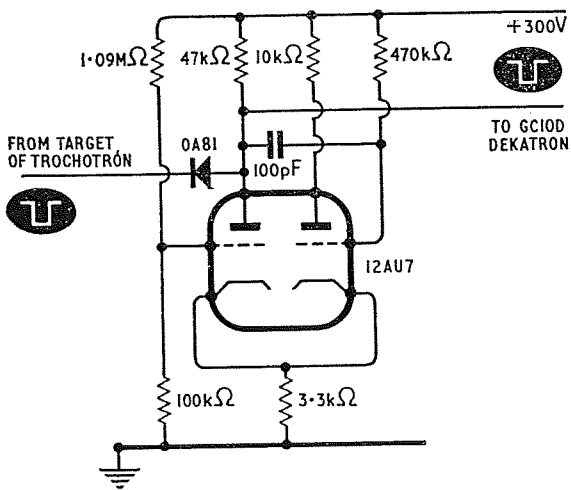

Fig. 6.15 A circuit for coupling a trochotron to a GC10D Dekatron

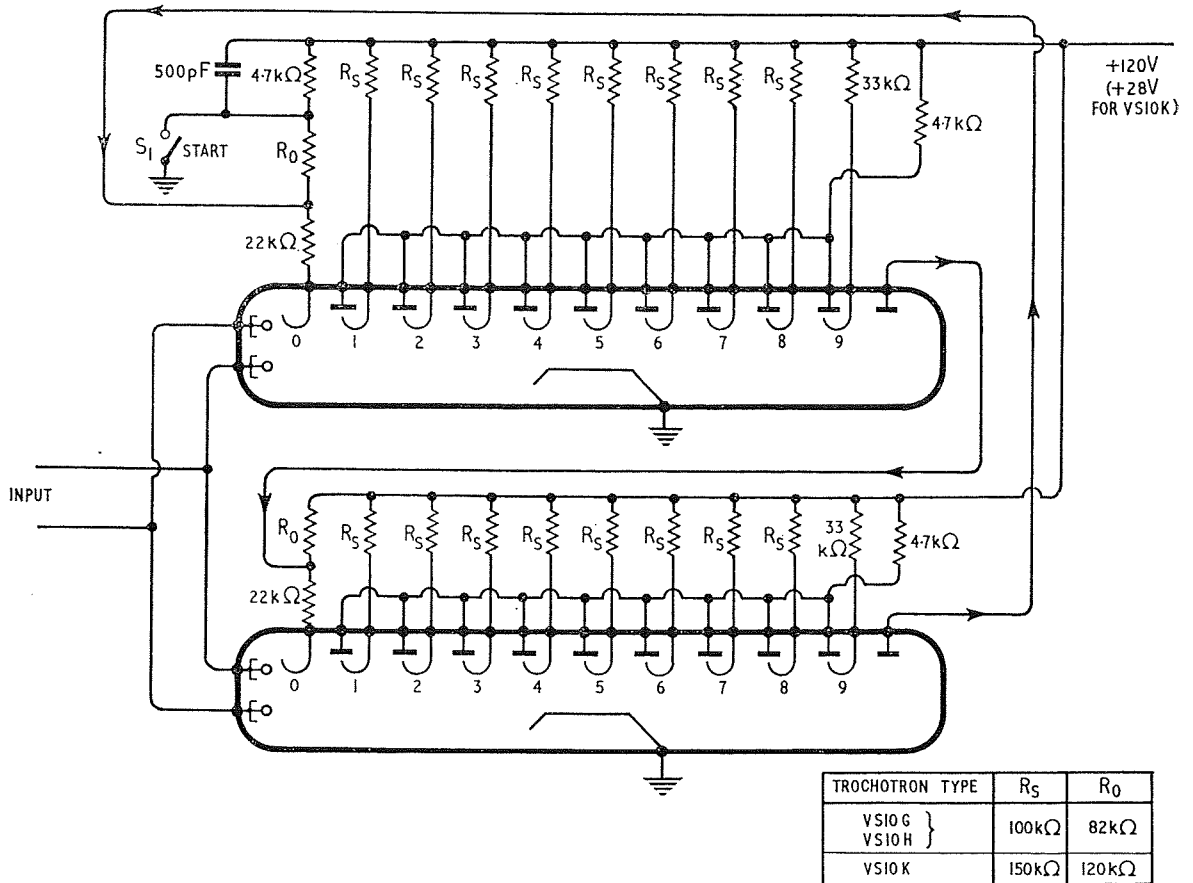

Fig. 6.16 A scale of eighteen circuit using two trochotrons

The circuit of Fig. 6.16 may be used to extend the number of stable positions up to $18^{(2, 13)}$. A third trochotron could be included in the ring to provide up to 27 stable positions. The ninth spade resistor of each tube has a smaller value than the other spade resistors so that the slope of its load line (Fig. 6.5) is greater than the maximum value for normal operation (R_{min}) but is small enough to cut the leading spade characteristic (curve II). When the beam reaches the ninth position, the target current flows for an instant and then the beam is extinguished in this tube. The pulse from the target is used to reduce the potential of the zero spade in the second tube so that the beam is formed in this tube. When the beam reaches the ninth spade in the second tube, it is automatically extinguished and a beam is re-formed in the first tube at the zero spade by the same process as that already discussed. The switching action from

tube to tube is very fast. A switch to form the beam in the first tube (S_1) is required. One of the input circuits discussed previously can be used, but it should be remembered that if several trochotrons are connected together in this way to obtain a large scaling factor, the input capacitance will be relatively large and a low impedance driving circuit will be required at high frequencies.

Any desired scaling factor can be obtained using trochotrons by combining the circuit techniques described above.

6.3.8 Circuits for Tubes Using Rod Shaped Switching Grids

The same basic circuits as those already described may be used for tubes which employ rod shaped switching grids, but the component values will be

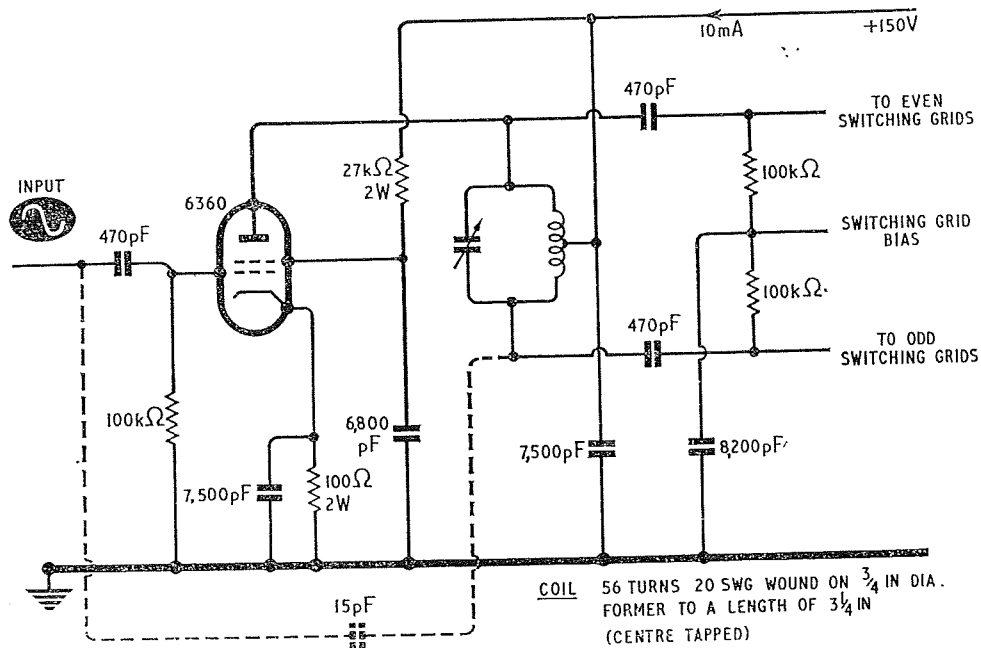

Fig. 6.18 A circuit for driving the MO-10R at 10 Mc/s from a sine wave input of 5 Mc/s

tube envelope so that the stray spade capacitance is reduced to a minimum. At 10 Mc/s the capacitance of even the rod type of switching grid becomes important and therefore buffer amplifiers are normally employed between the bistable circuit and the MO-10R at very high speeds. The pulses which are fed to the switching grids of this tube should have an extremely short rise time and an amplitude of about 150 V.

The circuit of Fig. 6.18 can be used to drive a MO-10R tube at 10 Mc/s when it is fed with a 10 V R.M.S. 5 Mc/s sine wave input signal⁽¹⁵⁾. The output voltage is greater than 300 V peak to peak at each switching grid. If the extra capacitor shown dotted is added in the position shown, a self oscillating Hartley circuit is formed which will drive the MO-10R without any input being required.

6.4 THE BURROUGHS 'BEAM X' SWITCHING TUBES

The Burroughs Beam X switch is basically a miniature trochotron with internal magnets. Initially a Beam X tube was produced with circular spade electrodes (each of which contained a magnet), circular switching grids and targets resembling those shown

in Fig. 6.3. The current Beam X tubes have circular target electrodes (each incorporating a magnet) and circular or rod shaped switching grids as shown in Fig. 6.19. In addition, extra electrodes known as shield grids have been introduced which offer alternative output facilities and, in some cases, simplified circuitry.

The use of internal magnets close to the electron beam renders the Beam X tubes less sensitive to stray magnetic fields than other beam switching tubes and simplifies the magnetic field requirements. In addition to their small size and weight, the Beam X tubes have the advantage of being appreciably cheaper than the other Burroughs beam switching tubes. Magnetically shielded versions of some of the Beam X tubes are available, the amount of shielding required being quite small. Such shielded tubes can be operated in contact with other tubes or with magnetic materials.

The beam current divides itself between the target and shield grid electrodes, whilst a small fraction flows to the spades. If the target electrode is at or above the spade supply potential, it will receive almost the whole of the beam current. As the target voltage is lowered, more of the beam current passes to the shield grid until the target reaches the cathode

potential, when almost the whole of the beam will travel to the shield grid. Either the target or the shield grid or both should have a potential above that of the spade supply voltage or the tube will switch automatically whatever the switching grid potential. The greater the target voltage, the greater the amplitude of the negative pulses required at the switching grid to move the beam to the next position. The ability of the shield grid to collect all of the excess electrons enables the tube to operate at low target potentials which may occur momentarily, for example, when the target load is inductive or when a gas filled tube which takes a minute fraction of a second to ionise is included in the target circuit. No target resistors or an additional target supply voltage (such as the +200 V supply in Figs. 6.11(a) and 6.11(b)) are required when Beam X tubes are used with numerical indicator tubes provided that the current taken by the indicator tube is the same as that provided by the Beam X tube. All of the shield grids of a Beam X tube are connected to a common base pin.

The methods of driving Beam X tubes are the same as those used for other beam switching tubes. The circuits which have already been discussed may be adapted for use with Beam X tubes by merely choosing suitable component values (Table 6.1). Normally bistable driving circuits are used, but at

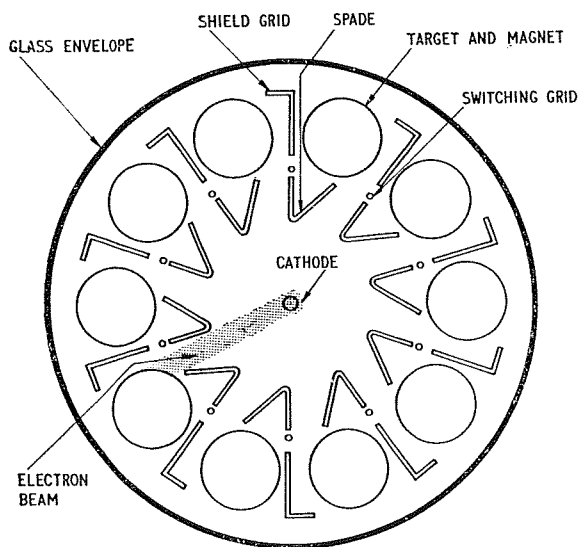

6.19 A Beam X tube seen in cross section

low operating speeds (less than 10 kc/s) the two sets of switching grids may be connected together and the switching accomplished by pulses of a limited duration (as in the circuit of Fig. 6.7).

General information on the principles of operation, design and applications of Beam X circuits for decade counting, bidirectional counting, preset decade counting, multiposition pulse distribution, step function generation, data transfer and storage, sampling, etc. has been published by the manufacturers of the tubes⁽¹⁶⁾.

A Beam X tube has also been specifically designed to provide decimal readout from binary coded information.

6.4.1 Beam X Circuits Using Valves

A decade circuit using a Burroughs 'Nixie' numerical indicator tube for readout is shown in Fig. 6.20⁽¹⁷⁾. The input pulses are fed to the 5695 bistable circuit and a negative supply voltage is used so that the 5695 tubes may be directly coupled to the Beam X switch. Output pulses suitable for operating the next decade are provided by the TI 496 NPN transistor. Small capacitors are connected from each spade to earth to increase the stability of the circuit.

A 1 Mc/s decade counter has been developed and is shown in Figs. 6.21 to 6.24 inclusive⁽¹⁸⁾. A Nixie tube is used to provide the readout. RCA 'Nuvistor' valves were chosen for driving and coupling the Beam X tubes owing to their small size, low anode resistance and good mechanical construction.

The input pulses (of 12 to 18 V amplitude and of at least 0.04 μ sec duration) are fed to the 1 Mc/s input stage of Fig. 6.21. Tetrodes are used in the bistable circuit of this decade so that a high speed binary circuit can be designed with a fairly low power dissipation. The anode potentials of the bistable circuit swing between about -18 and -90 V and these potentials are directly coupled to the Beam X tube switching grids. The spades are connected to a -20 V line via the spade resistors and the cathode of the Beam X tube has a quiescent potential of -75 V, thus giving the recommended spade supply voltage of +55 Volts relative to the tube cathode. The switching grids fall to a potential of -15 V relative to the Beam X cathode when the

ELECTRONIC COUNTING CIRCUITS

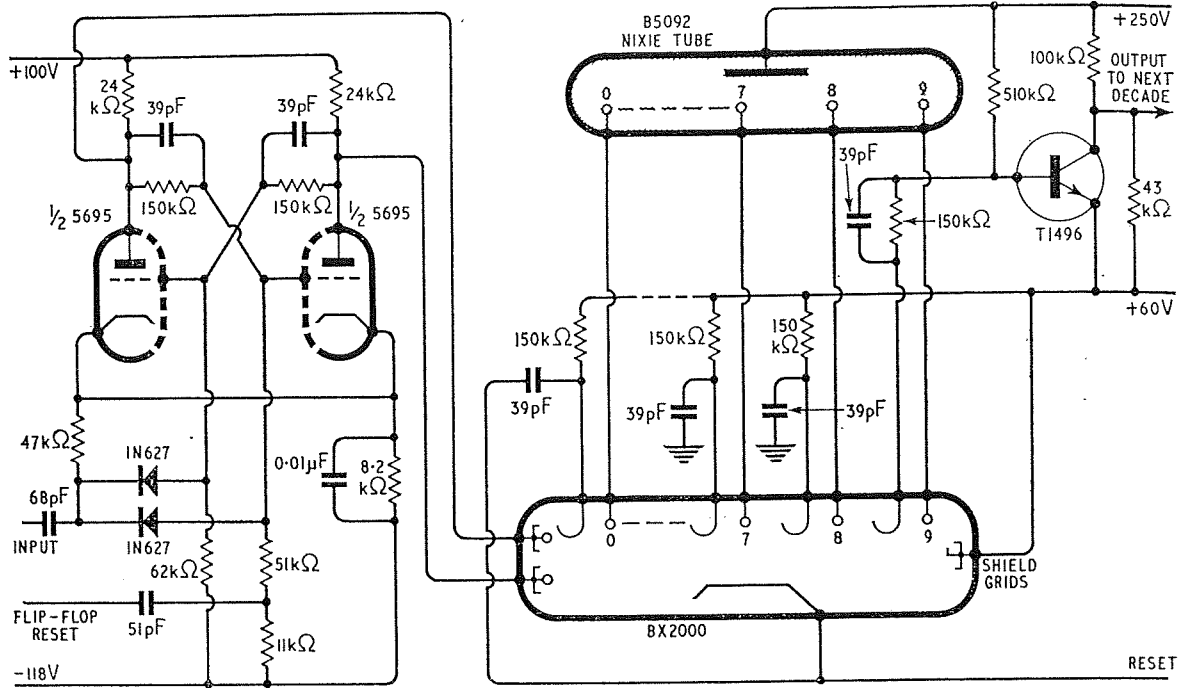

Fig. 6.20 A 110 kc/s Beam X circuit with Nixie tube readout

corresponding section of the binary conducts, this being sufficient to drive the circuit at up to 1 Mc/s.

The 7586 tube provides an 18 V pulse for operating the 100 kc/s decade of Fig. 6.22. This coupling tube operates from a -20 V supply. If the electron beam in the Beam X tube is not resting at position nine, the ninth spade current is zero and the coupling tube conducts. When the beam reaches position 9, the current in the coupling valve falls relatively slowly, but when the beam leaves the ninth position, the coupling valve anode current rises very rapidly. The resulting sharp negative pulse at the anode is used to trigger the next decade.

The 100 kc/s circuit (Fig. 6.22) is very similar to the 1 Mc/s circuit, but two 7586 Nuvistor triodes are employed in the bistable circuit. The anodes of the triodes drive the switching grids of the Beam X tube with a swing of -18 to -85 V. Stabilising capacitors are added to the spade circuits.

A cathode follower stage is used to provide a positive going output pulse of about 20 V amplitude for triggering the succeeding 10 kc/s decade. The cathode resistor of the coupling tube is associated with the input circuit of the next decade and is not

shown in Fig. 6.22; it is effectively returned to a -20 V supply. Normally the coupling tube is biased to cut off and will remain cut off when it receives a negative pulse as the ninth spade conducts. The coupling valve will not conduct until the beam moves from the ninth to the tenth position in the Beam X tube. A positive going output pulse is then obtained.

The 10 kc/s circuit of Fig. 6.23 is especially interesting, since the Beam X tube forms part of the feedback loop of the bistable circuit. The odd spades are returned to the grid of V1 and the even spades to the grid of V2. In the absence of even spade current, V2 will conduct owing to the positive grid bias applied to this tube through the 750 kΩ resistor. Similarly V1 will conduct when the odd spade current is zero. If the beam is in one of the even positions, a current of about 380 μA will flow in the even spade supply line and V2 will be cut off. If an input pulse is now received, V1 will remain conducting for a moment, but V2 will also pass a current, since the input pulse overcomes the bias due to the even spade current. A fall of potential of about 80 V is therefore fed from the anode of V2 to the even switching grids

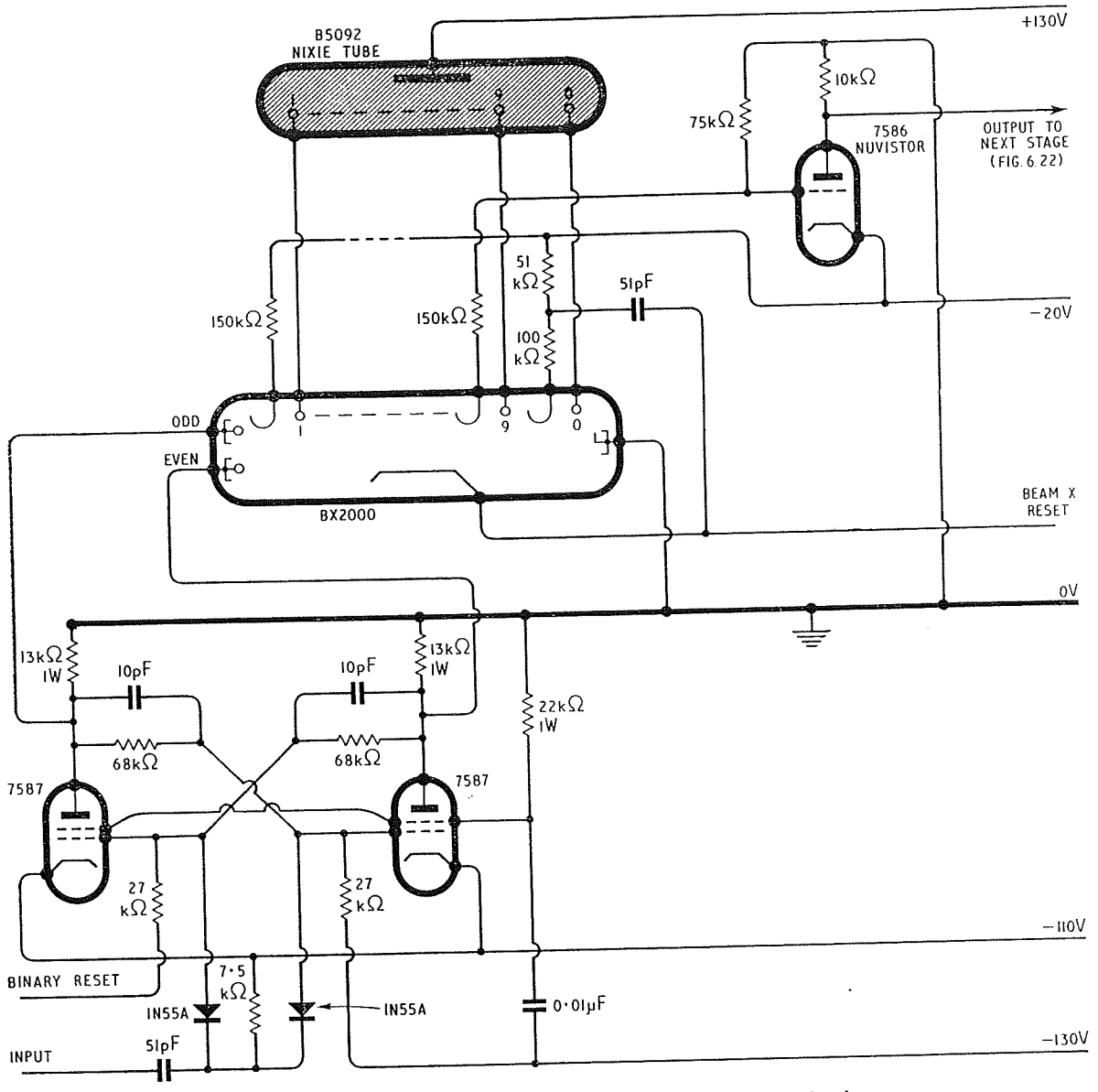

Fig. 6.21 A 1 Mc/s decade counter using R.C.A. 'Nuvistor' tubes

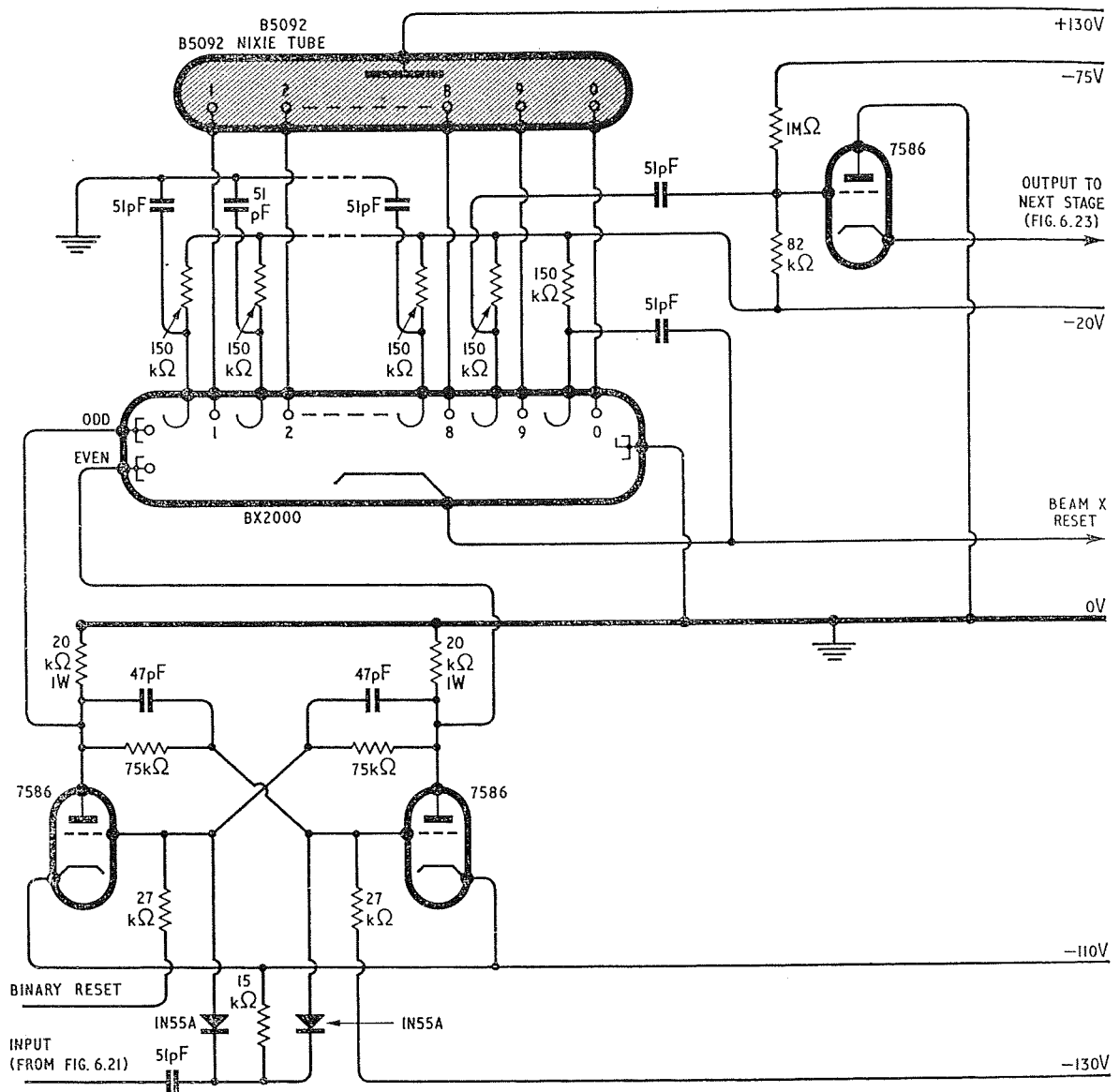

Fig. 6.22 A 100 kc/s Beam X stage

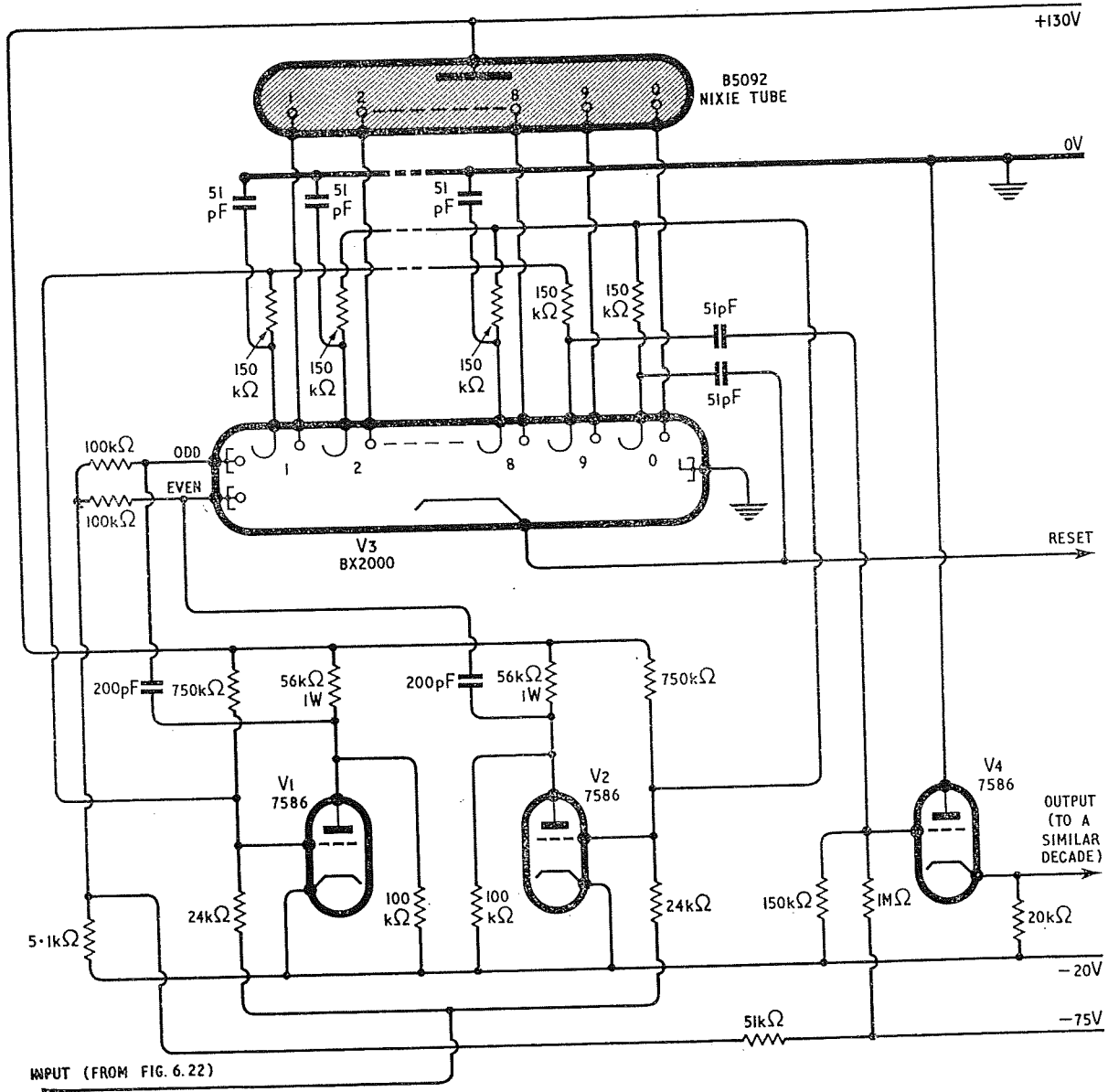

Fig. 6.23 A 10 kc/s Beam X stage

ELECTRONIC COUNTING CIRCUITS

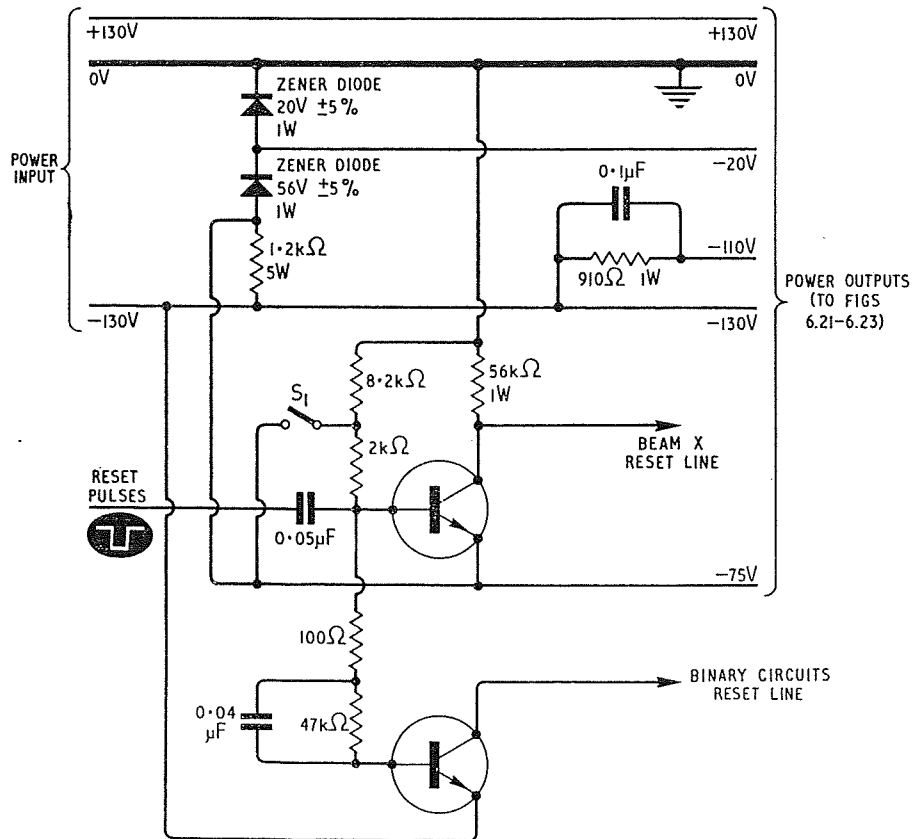

Fig. 6.24 Reset and power supply unit for Figs. 6.21–6.23

causing the beam to move to the succeeding odd position. The spade current therefore causes $V1$ to be cut off, whilst $V2$ remains conducting, since the even spade current is now zero.

The coupling circuit is similar to that of the 100 kc/s decade, since any further decades added will normally be of the same design as the 10 kc/s stage and will all require the same type of input pulses. An advantage is that the bistable circuit is automatically reset when the Beam X tube is reset.

A suitable method of obtaining the power supplies required to operate these counting circuits is shown in Fig. 6.24. A method for obtaining the two sets of resetting pulses is also shown. Both of the transistors are normally saturated, but resetting may be effected by the application of a negative pulse of about 15 V amplitude and 30 μ sec duration to the base of the upper transistor. This pulse is coupled to the base of the lower transistor and both transistors are cut off. Manual reset facilities are offered

by the switch S_1 . The upper transistor is cut off whilst this switch is closed, but the lower transistor is cut off for only a few microseconds, thus ensuring that the binary circuit is reset before the Beam X tube. A positive going pulse of about 75 V in amplitude and 30 μ sec in duration is required to reset the Beam X tubes.

If it is desired to construct a scaler using only the 100 kc/s units of Fig. 6.22, the type of coupling amplifier shown in the circuit of Fig. 6.21 should be employed so that the output pulses from this amplifier are of a suitable polarity to operate the 100 kc/s circuits. The cathode follower coupling circuit of Fig. 6.22 does not provide pulses suitable for the operation of a similar succeeding decade.

6.4.2 Low Frequency Circuit

One of the simplest possible circuits for a Beam X scaler is shown in Fig. 6.25⁽¹⁹⁾. A simple bistable

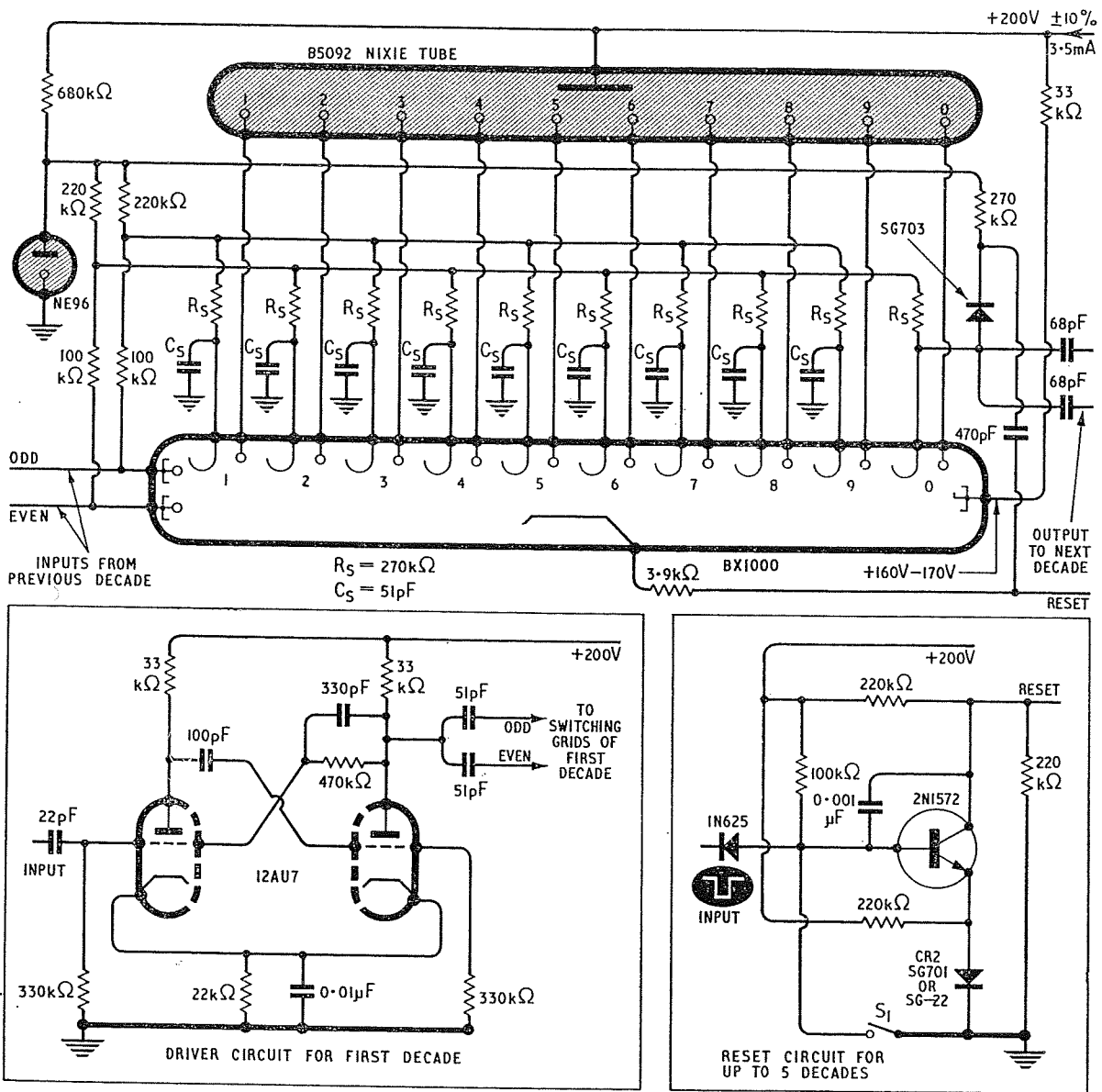

Fig. 6.25 A simple 1 kc/s Beam X circuit with input and reset circuits

valve circuit (as shown) may be used to drive the first Beam X tube, but no coupling amplifiers are required between the decades. This circuit is available in the form of modules (excluding the Nixie tube) from the manufacturers of the Beam X tube.

The beam is initially formed in the zero position by means of a reset pulse. The potentials of the switching grids depend on the voltage drop across the 220 k Ω spade supply resistors. When an even spade conducts, the potential of the even switching grids is kept near the switching level, whilst that of the odd switching grids is above this level. These potentials are reversed when an odd spade is conducting. At each input pulse the tube will therefore switch only one position. When the beam moves from position 9 to position 0, the flow of spade current through the zero spade resistor produces a negative going pulse of about 60 V amplitude and 150 μ sec duration which is used to operate the next decade.

The wires coupling one decade to the next decade should be kept as short as possible to minimise stray capacitance. A 200 pF capacitor should be connected between one of the unused output terminals of the final decade and earth.

The input required at the switching grids of the first Beam X tube is about -80 to -100 V for at least 5 μ sec. This may be obtained from the type of driver circuit shown which requires an input of at least -50 V for a minimum of 1 μ sec. Whatever type of input circuit is to be used, a 51 pF capacitor must be placed in each switching grid circuit of the first tube.

The pulses required to reset the Beam X tubes in this type of circuit should have an amplitude of 90 to 110 V for a minimum duration of 1.5 msec with a trailing edge duration of 90 to 130 μ sec. Such pulses are conveniently obtained by cutting off an NPN transistor in the reset circuit shown, the transistor being connected between the cathode of the Beam X tube and earth.

6.4.3 Circuits with Transistor Drive

Beam X tubes, transistors and small numerical indicator tubes form very convenient components for use in plug in modules for fairly high speed counting

when they are mounted on printed circuit boards. Such modules (including the Nixie indicator tubes) are available commercially, two of the most useful circuits being shown in Figs. 6.26 and 6.27⁽¹⁹⁾. The first of these circuits is a 1 Mc/s decade counter with a transistor coupling amplifier which provides suitable output pulses for the operation of the 100 kc/s decade counter of Fig. 6.27. Any number of the decade circuits shown in Fig. 6.27 may be cascaded, since the output pulses from these units satisfy their input pulse requirements.

The beam is formed at the zero spade in the circuit of Fig. 6.26 by the application of a reset pulse. The input pulses should have an amplitude of $12\text{ V} \pm 15\%$ and a minimum duration of 0.3 μ sec. They are fed to the bistable circuit which uses Fairchild S-3281 transistors to drive the Beam X tube.

The NS422 transistor in the coupling circuit is used to provide output pulses which will operate the circuit of Fig. 6.27. If the circuit of Fig. 6.26 is counting at 1 Mc/s, the beam current is available at any one target for only 1 μ sec, but the 100 kc/s circuit requires a pulse of at least 2 μ sec duration. When the beam is at any of the positions 4, 5, 6, 7, 8 or 9, spade current flows through the 560 k Ω resistor connected to the base of the coupling transistor making the base more negative and cutting the NPN transistor off. The output potential (about 90 V) is then determined by the values of the 330 k Ω and 30 k Ω resistors connected to the output. When the beam moves to the zero position, the coupling transistor conducts again and the potential of its collector falls to about 78 V, thus providing the required 12 V negative step.

The alternative reset connection is normally earthed in the reset circuit. The reset transistor (inset of Fig. 6.26) normally conducts and holds the cathode of the Beam X tube at about earth potential. If the reset transistor is turned off for 25 μ sec or more, the cathode will reach a potential of 80 to 100 V and the beam will be cut off. When the transistor conducts again, the zero spade is held at a low potential by a capacitor so that the beam forms in the zero position. A 10 V positive going pulse is applied to reset the binary at the same time as the Beam X tube is reset. A single reset circuit will operate up to six decades.

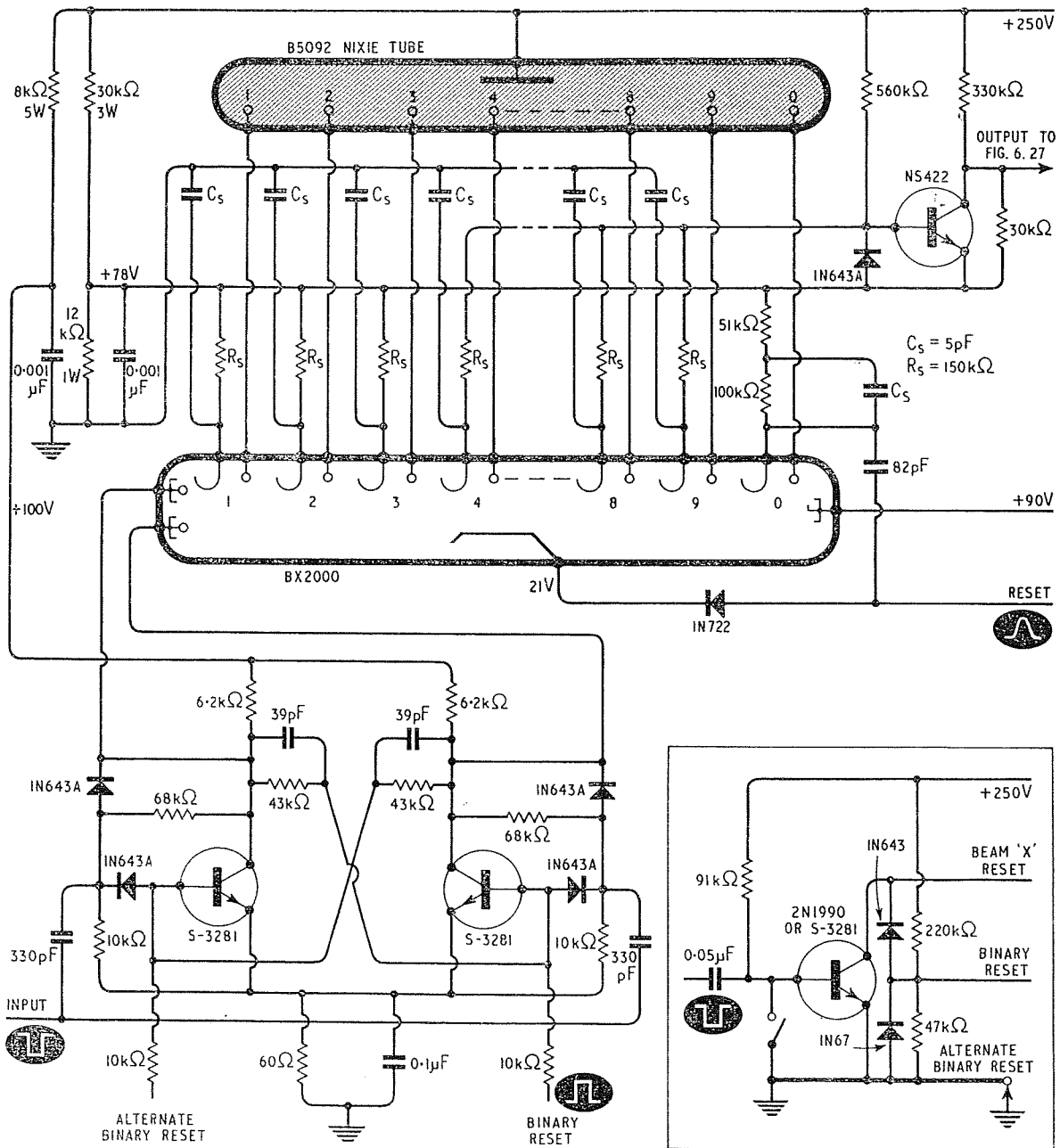

Fig. 6.26 A 1 Mc/s circuit with transistor drive. (Inset: reset circuit)

Table 6.1 BEAM SWITCHING TUBES, BASIC DATA

Unshielded Tubes	Shielded Versions	Max. freq. (Mc/s)	Target current (mA)	Spade current (mA) Typical	Recommended Operating Conditions				Max. Dimensions				Heater		Remarks		
					Spade Supply voltage (V)	Spade Resistor (Ω)	Target Supply voltage (V)	Target Resistor (Ω)	Grid Bias (volts)	Pulse input	Unshielded Seated Height (mm)	Unshielded Diam (mm)	Shielded Seated Height (mm)	Shielded Diam (mm)		V	A
<i>Ericsson Trochotrons</i> VS10G (CV5290) VS10H (CV6103) VS10K	VS10G/M VS10H/M —	1	10	1.2	108	100k $\pm 10\%$	108	4.7k	+54	-54	81.5	44	81.5	75	6.3	0.5	Low cost tube
		2	18	1.0	125	82k	125	4.7k	+62	-67	81.5	44	81.5	75	6.3	0.55	High current
		1	2	0.4	28	150k	28	6.8k	+15	-17	81.5	44	—	—	6.3	0.3	Low voltage
		—	—	—	—	—	—	—	—	—	—	—	—	—	—	—	—
<i>Mullard/Philips Trochotron</i> ET51 (CV5277)	—	1	5.5	1.0	100	100k $\pm 10\%$	100	3.3k	+30	-75	84	44.4	—	—	6.3	0.5	General purpose
		—	—	—	—	—	—	—	—	—	—	—	—	—	—	—	—
<i>Burroughs Trochotrons</i> 6700 6701 BD311 MO-10R (6704) BD-203	BD301 (6703) BD308 — BD309 BD-316	2	6	1.0	100	100k	100	3.3k	+25	-50	84	44.5	82	57.5	6.3	0.3	General purpose
		1	0.6	0.1	20	270k	20	6.8k	+12	-20	84	44.5	82	57.5	6.3	0.3	Low voltage
		2	10	1.7	130	82k	130	3.3k	+30	-70	84	44.5	—	—	6.3	0.3	High current
		10	6	1.0	100	100k (Internal)	100	3.3k	+25	-60	84	44.5	82	57.5	6.3	0.3	High speed
1	3	0.5	55	130k	55	3.3k	+25	-50	82	33	82	44.5	44.5	6.3	0.15	Miniature (superseded by Beam X switches)	

Unshielded Tubes	Shielded Versions	Max. freq. (Mc/s)	Target Current (mA)	Spade current (mA)	Recommended Operating Conditions					Max. Dimensions				Heater		Remarks		
					Spade Supply voltage (Ω)	Spade Resistor (Ω)	Target Supply voltage	Target Resistor (Ω)	Grid Bias (volts)	Pulse Input	Unshielded Seated Height (mm)	Unshielded Diam (mm)	Shielded Seated Height (mm)	Shielded Diam (mm)	V		A	
Burroughs Beam X Tubes BX1000 (6710) BX3000 (6712) — —	BX2000 (6711) — BX4000 BX4001 (6714)	2 2 1 2	2.7 5.0 1.0 1.0	0.4 0.5	55 80 30	150k 150k 270k	55 55 30	3.3k 3.3k 10k	+40 +50 +26	—55 —55 —24	73 73 — 73	29.5 29.5 — 32.5	73 — 73	32.5 — 32.5	6.3 6.3 6.3	0.15 0.15 0.15	General purpose High current Low voltage (BX4000 superseded by BX4001) Specially tested for decoding of binary coded decimal information	
—	BX2012	←	← As for BX 2000					→	→	→	→	→	→	→	→	→	→	→

Base connections:

VS10G, VS10G/M, VS10H, VS10H/M, VS10K, VS10K, ET51, 6700, BD301 and BD311:

Pin	1	2	3	4	5	6	7	8	9	10	11	12	13	14	15	16	17	19	19	20	21	22	23	24	25	26	27
Electrode	S_0	T_9	T_8	SG_{odd}	T_7	S_7	T_6	S_5	T_4	I.C.	T_3	T_2	S_2	T_1	SG_{even}	T_0	S_9	S_8	h	S_6	S_4	S_3	S_8	h	S_1	k	

B27A base.

All Beam X tubes: — As above, but pin 11 is the common shield grid connection. 6701, BD203, BD308 and BD316: — As above except that pin 16 is connected to the zero switching grid whilst all other even grids are connected to pin 11.

MO-10R and BD309:

Pin	1	2	3	4	5	6	7	8	9	10	11	12	13	14	15	16	17	18	19	20
Electrode	S_0	T_8	SG_{odd}	T_7	T_6	T_5	S_1 to S_9	T_4	T_3	SG_{even}	T_2	T_1	T_0	k	T_9	h	NC	NC	H	NC

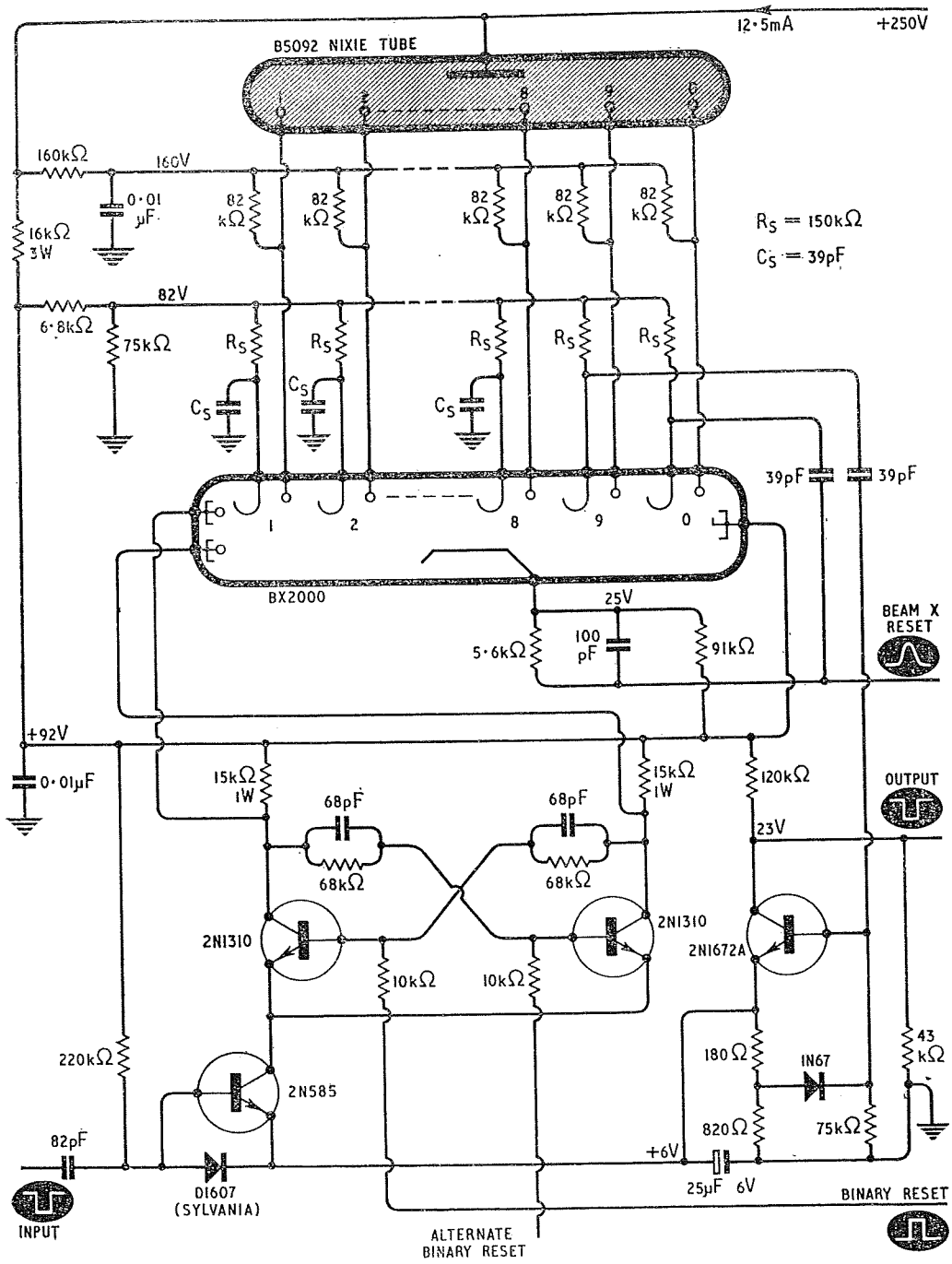

Fig. 6.27 A 100 kcs circuit with transistor drive

An additional transistor is used in the input of the 110 kc/s circuit of Fig. 6.27. The input pulses are differentiated by the input capacitor and resistor and are then used to cut off the 2N585 transistor for a period which is longer than that required for the binary circuit to change its state. The NPN 2N1672A coupling transistor is normally cut off.

When spade nine conducts, the negative pulse applied to the base of this transistor will therefore have no effect. As the beam advances to the zero position, however, a positive pulse is fed to the coupling transistor which conducts for about 10 μ sec and a negative going output pulse of about 17 V amplitude is obtained.

REFERENCES

1. S. P. FAN, 'The magnetron beam switching tube', *J. Brit. I.R.E.*, **15**, 335, (1955).
2. D. REANEY, 'Trochotron high-speed beam switching tubes'. *J. Brit. I.R.E.*, **23**, 99 (1962).
3. H. ALFVÉN & H. ROMANUS, 'Valve with trochoidal electronic motion'. *Nature*, **160**, 614 (1947).
4. H. ALFVÉN, L. LINDBERG, K. G. MALMFORS, T. WALLMARK & E. ASTRÖM. 'Theory and applications of trochotrons'. *Trans. Roy. Inst. Technol., Stockholm*, **22** (1948).
5. The Ericsson Tube Technical Handbook.
6. Trochotron Beam Switching Tubes, Ericsson Telephones Ltd. B. 6003/1 issue 2 (1962).
7. Ericsson circuit LK 165.
8. Ericsson circuit LK 164.
9. Stabilizer and Reference Tubes, Ericsson Telephones Ltd. B. 6201/1 (1962).
10. Digitron Display Tubes, Ericsson Telephones Ltd. B. 6207/2 issue 2 (1962).
11. Ericsson circuit LK 192.
12. Ericsson circuit LK 167.
13. Ericsson circuit LK 183.
14. Mullard Ltd. (Private Communication) and ET51 data sheets.
15. Burroughs circuit 70351.
16. 'Beam X Applications Orientated Switch', Burroughs Technical Brochure BX535C (1965).
17. 'Nixie Indicator Tubes', Burroughs Technical Brochure 616.
18. 'A Beam X Switch 1 Mc/s Counter'. Burroughs Publication 602 (August 1962).
19. 'Beam X Modules and Circuits' Burroughs Technical Brochure 405B (1965).

Valve Scaling Circuits

The binary circuits described in this chapter are in their zero state when the right-hand valve of each binary is conducting. This does not, however, apply in the case of the ring of binary circuits shown in Fig. 7.7.

Ordinary high vacuum thermionic valves can operate at very high speeds, but it is normally convenient to use them only in binary circuits for counting, either as simple cascaded binaries or as decade counters consisting of groups of four binaries with feedback (see Chapter 1). In decade circuits eight valves per decade are required but, if double triodes are employed, four of the double tubes per decade can be used. It is not easy to use hard valves in ring circuits, since they do not have two characteristic stable states such as those of trigger tubes or four layer diodes.

The space occupied by a valve counting decade is relatively large and the power consumed results in much heat being generated. Resolving times of less than 1 μ sec can be obtained with careful circuit design and component layout.

7.1 BINARY COUNTERS

The simple valve bistable circuit is basically that which was first described by Eccles and Jordan in 1919⁽¹⁾; it has been discussed in Chapter 1. Before the invention of semiconductors and decade tubes, valve binary circuits were the only available means for counting pulses at fairly high speeds. Such circuits were, therefore, much used in nuclear research and radio-isotope work, the most common form of readout being obtained by means of small neon diodes in the valve anode circuits. Valve scaling circuits are still being used in some modern

equipment, but as high speed semiconductors become cheaper, they are tending to gradually replace many of the valve circuits, since printed circuit techniques using semiconductors enable very compact apparatus to be constructed.

The two valves in each binary circuit behave as switches which are alternately opened and closed. At any one time one of the two valves in each binary is conducting. Thus two stable states are possible. The conducting valve takes grid current, its grid being at approximately the same potential as the cathode. The grid of the non-conducting valve is driven well beyond cut off. The operating point on the valve characteristics thus moves over a large range and therefore the characteristic cannot be approximated to a straight line. This means that the normal small signal equivalent circuits of the valve cannot be used in circuit design, since the mutual conductance, amplification factor and internal anode resistance vary considerably in value as the operating point moves along the characteristic curve. The detailed analysis of valve binary circuit design, however, has been published elsewhere⁽²⁾.

7.1.1 Capacitor Coupling

When a binary stage is switched, the pulse produced at the anode of each tube approximates to part of a rectangular wave and is, therefore, suitable for the operation of a succeeding binary stage. A binary

stage may be triggered by the application of successive input pulses of alternating polarity to the grid of one valve, but it is normally much more convenient to apply input pulses of constant polarity to the grids of both valves in the binary. This may be

C_1 and C_3 should normally be somewhat larger than the input capacitors C_2 and C_4 .

The zero state of the circuit occurs when $V1b$ and $V2b$ are conducting and the other two triodes are cut off. If the circuit is in the zero state and a

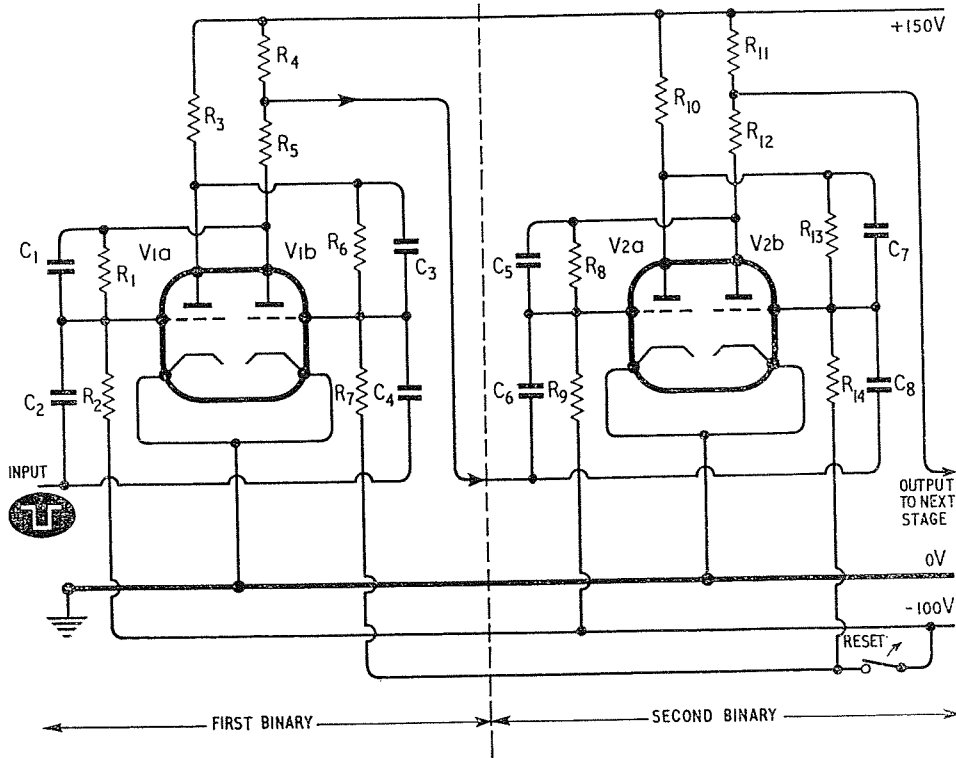

Fig. 7.1 Two cascaded binary circuits

done by means of capacitive coupling as in the circuit of Fig. 7.1 in which two cascaded binary stages are shown. The components C_2R_2 and C_4R_7 effectively differentiate the input pulses before they reach the grids of the first binary.

The capacitors C_1 and C_3 are connected across the feedback resistors R_1 and R_6 so that the high frequency components of the waveform at each anode can reach the grid of the other valve in the binary almost unaffected by the stray grid to earth capacitance. If C_1 (or C_3) were omitted, the resistor R_1 (or R_6) and the stray grid capacitance would effectively integrate the high frequency components of the anode waveform. The steep leading edge of the anode waveform would then not reach the grid and this would result in an increased resolving time.

negative going pulse is applied at the input, the pulse will reach the two grids of the first binary via C_2 and C_4 . It will not immediately affect the anode current of $V1a$, since this tube is cut off, but it will reduce the anode current of $V1b$. The anode of $V1b$, therefore, becomes more positive and the positive pulse is fed to the grid of $V1a$ via C_1 and R_1 . As soon as $V1a$ begins to conduct, its anode potential will fall and this results in the grid potential of $V1b$ falling also owing to the presence of the coupling components R_6 and C_3 . Thus a cumulative effect occurs at the end of which $V1a$ is conducting and $V1b$ is cut off. The junction of R_4 and R_5 becomes more positive during the switching operation and this positive pulse is coupled to the grids of the second binary stage. It will not appreciably

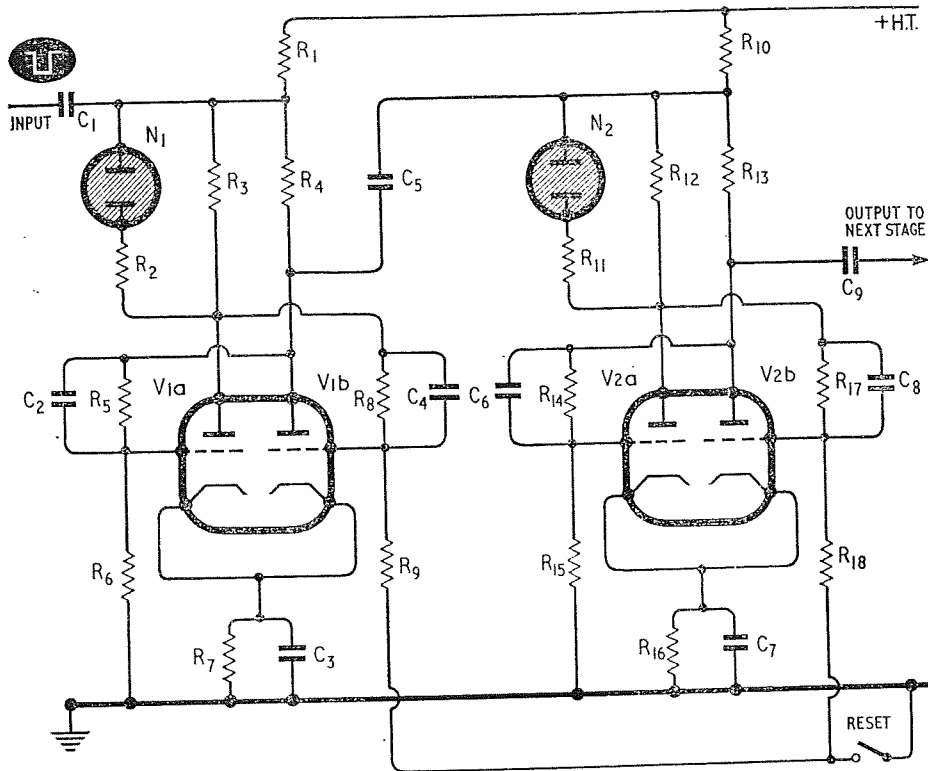

Fig. 7.2 Two cascaded binaries with anode coupling and neon readout

affect the valve which is already conducting ($V2b$) and is of too small an amplitude to reduce the large negative bias at the grid of $V2a$ to a point at which this tube commences to conduct. Thus the second binary remains in the zero state.

A second negative going pulse applied at the input will cause $V1a$ to return the non-conducting state; that is, the first binary is returned to zero. A negative pulse will be formed at the junction of R_4 and R_5 when $V1b$ conducts and this will have an amplitude which is sufficient to cut off the conducting tube in the second binary, $V2b$. Thus the second binary is switched at the second input pulse.

The third input pulse switches $V1a$ to the conducting state. The positive pulse formed at the anode of $V1b$ does not affect the second binary. The fourth pulse switches the first binary back to zero and a negative going pulse from the anode circuit of $V1b$ switches the second binary back to zero. The second binary provides a negative going output pulse which can be used to switch a third binary stage.

The capacitors C_2 , C_4 , C_6 and C_8 in Fig. 7.1 prevent interaction of the two d.c. grid potentials of any stage, block the steady potential from the anode of the previous binary, and convert the pulses into sharp peaks by differentiating them. The reset switch can be used to disconnect the grids of $V1b$ and $V2b$ from the -100 V line. The grid potentials of these tubes will then rise, since the grids are coupled to the anode of the other tube in the binary. Thus the circuit is reset to zero.

The triggering of valve binary stages is almost invariably carried out by the negative edges of the input waveform. This is because the grid voltage of a conducting triode in a bistable circuit is approximately equal to the cathode potential of the tube and the stage can, therefore, be triggered by negative going pulses of a few volts in amplitude. By a suitable choice of component values it can be arranged that the grid of the valve which is cut off is at a potential well below that of the cathode and the positive edges of pulses of a normal amplitude do not, therefore, affect the circuit, since they do not raise

the grid potential of the cut off valve to a value at which anode current commences to flow. Nevertheless, the positive going edges will produce a transient increase in the anode current of the conducting tube. Another reason for the use of negative going edges of pulses for triggering valve bistable circuits is that the negative edges from the anode of a previous binary stage have a greater slope than the positive edges; when they are differentiated by the input capacitors they, therefore, produce pulses of greater amplitude than those produced by the positive going edges. It is possible to use positive going pulses for triggering valve binary stages provided that the negative pulses are removed by diodes but this merely complicates the circuitry and does not have any advantages.

The circuit of Fig. 7.1 can be used to divide the incoming pulse rate by a factor of four, but no form of readout is provided. It would be possible to include meters in series with R_3 and R_{10} so that when $V1a$ or $V2a$ is conducting, a current is indicated by the corresponding meter. Another form of readout which is more commonly used is shown in Fig. 7.2; it consists of two neon tubes (N_1 and N_2) placed across the anode resistor of the left hand triode of each binary stage. When one of these triodes conducts, the voltage developed across R_3 or R_{12} will cause the corresponding neon tube to glow. When $V1b$ and $V2b$ are conducting, neither neon is glowing and the count is zero. After the first input pulse N_1 glows, after the second input pulse N_2 only glows, whilst the third input pulse causes both N_1 and N_2 to glow. Both neons are extinguished at the fourth input pulse. Thus the readout is binary in nature.

The bias required for the triodes of Fig. 7.2 is developed across the cathode resistor of each stage. Anode coupling from the first binary to the second occurs via C_5 . This method of coupling enables the stray grid capacity to be minimised. If the circuit is first switched to zero by means of the reset switch, $V1b$ and $V2b$ will conduct. A negative pulse applied at the input will momentarily reduce the potentials of both anodes of the first binary. A part of this potential drop will be communicated to the grids by means of the coupling components. The fall in grid potential will not produce any effect in the

non-conducting valve, but it causes the anode current of the conducting valve to fall and initiates the cumulative action which results in the switching of the first binary. The positive pulse produced at the anode of $V2b$ is passed to the second binary, but its amplitude is insufficient to cause the stage to switch.

Common anode resistors are used in the circuit of Fig. 7.2. A similar circuit can be designed in which the common resistor is included in the cathode circuit, but in this case positive going pulses capacitively fed to the cathode are required to switch the circuit. The amplification is reduced by the presence of the common cathode resistor and larger values of anode resistor may therefore be required. This results in increased switching time and such circuits are, therefore, not normally used.

7.1.2 Diode Coupling

The resolving time of valve counting circuits may be reduced if diodes are employed as the coupling elements between the binary stages (as shown in Fig. 7.3) instead of the coupling capacitors used in the circuits described previously. In addition, the use of diode coupling is said to reduce the probability of spurious counts being recorded. Suitable semiconductor diodes may be used in place of the thermionic diodes. The cathodes of the first diodes ($V1$ in Fig. 7.3) must receive a suitable positive bias in addition to the negative going input pulses. A suitable potential divider is shown, but the pulses are normally derived from the anode circuit of a valve which also supplies the positive bias.

If the circuit is reset to zero, the right-hand triode of each binary conducts. When a negative going pulse is applied, the upper diode of $V1$ will prevent the pulse from reaching the conducting triode of $V2$, since the anode potential of the conducting triode is less than the positive bias voltage applied to the diode cathodes. The anode of the left-hand triode of $V2$ is, however, at the full H.T. potential, since this valve is not conducting. The lower diode of $V1$ is thus forward biased and the input pulse can pass through it to the anode of the left-hand triode of $V2$. The pulse is coupled to the grid of the right-hand triode which is thus cut off and the stage

across the right-hand triodes so that they glow when these triodes are non-conducting.

When the reset switch is operated, the triode on the right-hand side of each binary will conduct and no neons will glow. The first negative going input pulse will be routed by the $V5$ diodes to the anode of $V6a$ and will then pass through the parallel resistor and capacitor to the grid of $V6b$. $V31$, therefore, ignites.

The second negative going input pulse switches $V6$ back to the zero state and a negative going pulse from the anode of $V6b$ is applied to the cathodes of $V13$. The anodes of $V12b$ and $V13a$ are at a fairly low potential, since $V12b$ is conducting. $V13a$, therefore, prevents the pulse from passing to $V12b$. The pulse can, however, pass through $V13b$ to $V7$ and it then switches $V8$. $V11a$ is non-conducting, since its cathode is at the H.T. supply potential.

The next few pulses are counted in the normal binary manner, negative going pulses from the $V6b$ anode circuit passing through $V13b$ and either $V7a$ or $V7b$. At the eighth input pulse $V12$ is switched. The potential of the anode of $V12b$ now rises to a value equal to that of the H.T. line (since the valve is no longer conducting) and, therefore, the diode $V13a$ can pass negative going pulses to the anode of $V12b$. The ninth pulse merely switches $V6$, but at the tenth input pulse the negative pulse occurring in the anode circuit of $V6b$ passes through $V13a$ to the anode of $V12b$ and hence to the grid of $V12a$. $V12$ is, therefore, switched and provides an output pulse to the next decade. The pulse from $V6b$ cannot pass through $V13b$ to operate $V8$ because the anode current being taken by $V12a$ (immediately before $V12$ is switched back to zero) reduces the cathode voltage of $V11a$ and this in turn reduces the anode voltage of $V13b$ to a point at which the latter is cut off. Soon after $V12$ has returned to the zero state, $V13b$ will conduct again and $V13a$ will be cut off. All of the binaries are now in their zero state and the circuit is ready to count the next ten impulses. The binary numbers omitted are ten to fifteen inclusive.

The first binary stage used in Fig. 7.4 takes a current of about 13 mA and can operate at the highest frequency. The component values used in the three succeeding binaries allow a conducting triode

to pass about 10 mA. In the 1009E scaler the decade shown is followed by a decade working on similar principles, but employing binary stages which each pass about 5 mA. This economises in current and reduces the heat dissipation, but nevertheless a cooling fan is normally used with a 1009E scaler. The two valve decades are followed by an electro-magnetic counter which limits the maximum continuous counting speed of the scaler (but not the resolving time for a limited number of pulses). This type of scaler may be used at high frequencies if the output from the second valve decade is fed into another scaler of the same type; alternatively a Dekatron add-on unit may be employed⁽⁴⁾.

7.1.4 Decade Circuit with GR10A Readout

High speed valve scaling circuits are often followed by simpler but slower cold cathode decade tube counting circuits. In such cases it is desirable to provide a similar visual display of the state of the count in the valve circuits to that provided by the cold cathode decade tubes. This can be achieved by the use of certain indicator tubes such as the GR10A, the Z503M, etc. to provide readout from the valve decades.

A typical circuit of this type is shown in Fig. 7.5, this being the first decade of the Ecko N530F automatic scaler⁽⁵⁾. In this circuit the gating diodes, $V47$, are arranged so that a scale of ten is formed by the omission of the numbers 6, 7, 8, 9, 14 and 15 from the binary scale of 16. The effect of the applied input pulses is as shown in Table 7.1, the binary numbers shown in brackets being possible intermediate states which are included for explanatory purposes only.

When the circuit has been reset, the right hand triode of each of the binaries $V5$, $V7$, $V9$ and $V11$ conducts. The grid of $V9a$ is therefore at a potential considerably below the cut off potential of this valve and this results in the diode $V47a$ being in a non-conducting state, since its anode is connected to the grid of $V9a$. Similarly $V47b$ is non-conducting.

The first few pulses are counted in the normal binary manner unaffected by the presence of $V47$. The fourth pulse switches $V9$ and the change in the grid potential of $V9a$ renders $V47a$ conducting. The

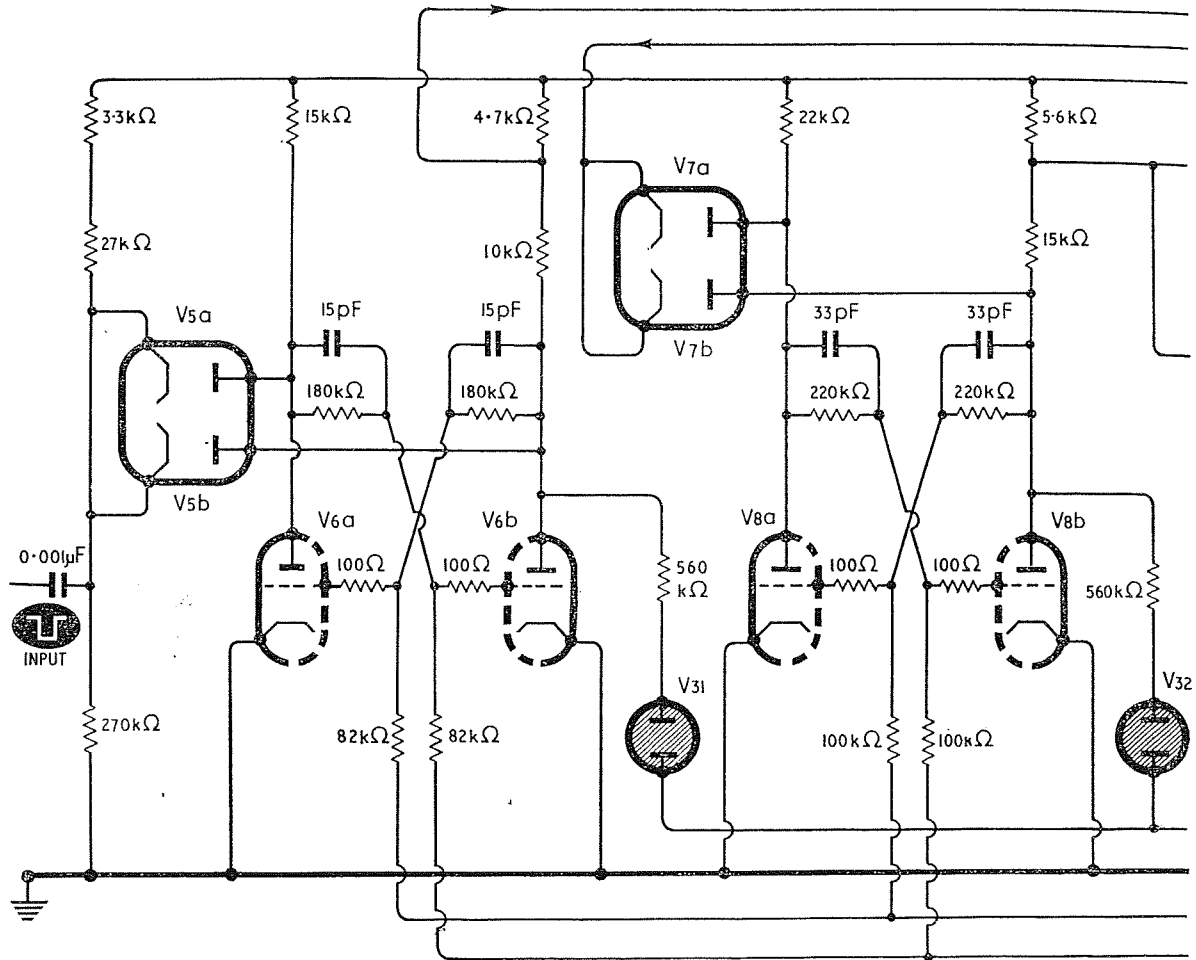

$V_5 = V_7 = V_9 = V_{11} = V_{13} = CV4007 = 6AL5 = CV140$
 $V_6 = V_8 = V_{10} = V_{12} = CV4031 = M8081 = 6J6 = ECC91 = CV858$
 $V_{31} = V_{32} = V_{33} = V_{34} = CV2213 = NT2$

Fig. 7.4 A valve decade using gating diodes

fifth input pulse merely switches V_5 , since the positive going output pulse from V_5b cannot pass through either V_6 or V_7 from cathode to anode. The sixth input pulse switches V_5 and the resulting negative going output pulse from V_5 passes through V_7a and switches V_9 . In addition the output pulse from V_5 also passes through V_6 and switches V_7 . Thus the decade jumps to the binary number 1010 which is ten. V_9a is now in the cut off state and, therefore, the routing diode V_7a becomes non-conducting again. The seventh, eighth and ninth input pulses are counted in the normal binary manner, but the eighth pulse switches V_9 and so allows V_7a to conduct. The tenth pulse switches V_5 back to

zero and the output pulse from V_5b passes through V_7a to switch V_9 to zero and also through V_6 to switch V_7 so that the latter indicates a count. The output pulse from V_9 switches V_{11} to zero and a pulse from the anode of V_{11b} is passed back through V_7b to switch V_7 to zero. The binaries are at zero and V_{11b} has provided a pulse to the next decade.

The system of readout used in the circuit of Fig. 7.5 must convert the binary electrical readout from the anodes of the binary stages into a visual decade readout. The digit to be indicated is determined by the state of a number of the binaries taken together. The circuit potentials are chosen so that

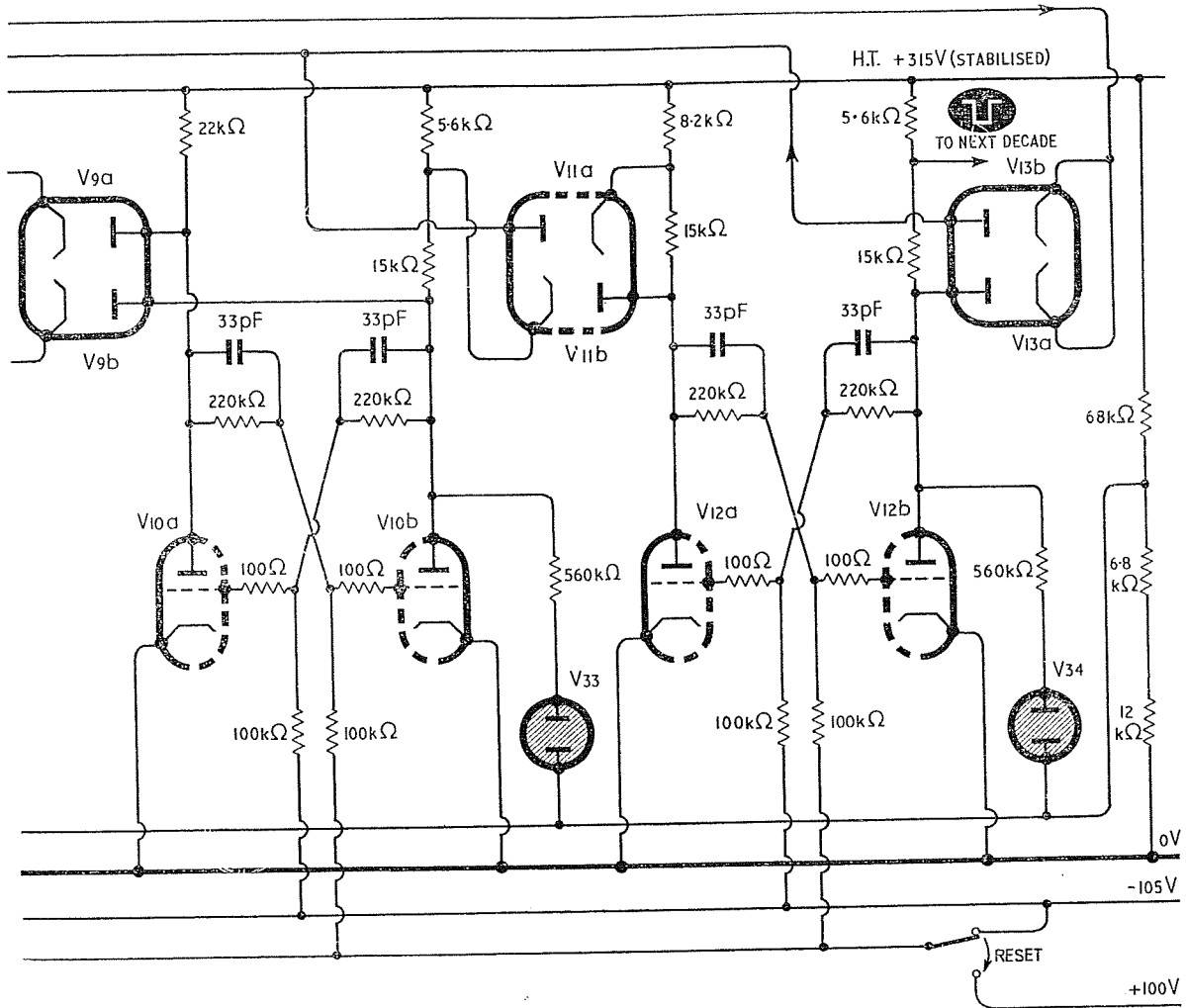

and neon readout. (Part of 1009E scaler)

if one of the cathodes of the indicator tube is connected (via resistors) to a number of the binary tube anodes, all of these anodes must be passing current if the cathode of the indicator tube is to be at a low enough potential to glow. For example, the triodes *V5b*, *V7b*, *V9b* and *V11b* are conducting when the circuit has been reset to zero. If the zero cathode of the indicator tube is connected via resistors to the anodes of each of these triodes, the zero cathode will glow only when all four of the triodes are conducting. This occurs only when the state of the count is zero. If the connection from the zero cathode of the indicator tube to the anode of *V5b* were omitted, the cathode would glow when the

other three triodes were each passing current. This occurs at counts of zero and one; the omission of the connection would, therefore, result in ambiguous indications of the state of the count. On the other hand the connection between the zero cathode of the indicator tube and the anode of *V11b* can be omitted, since the other three triodes will all conduct simultaneously only at the binary states of 0 and 8, and the 8 is one of the six binary states which have been eliminated by the feedback.

As another example, the state of the circuit can be considered after five input pulses when *V5a*, *V7b*, *V9a* and *V11b* are conducting. If all four anodes are connected to the fifth cathode of the

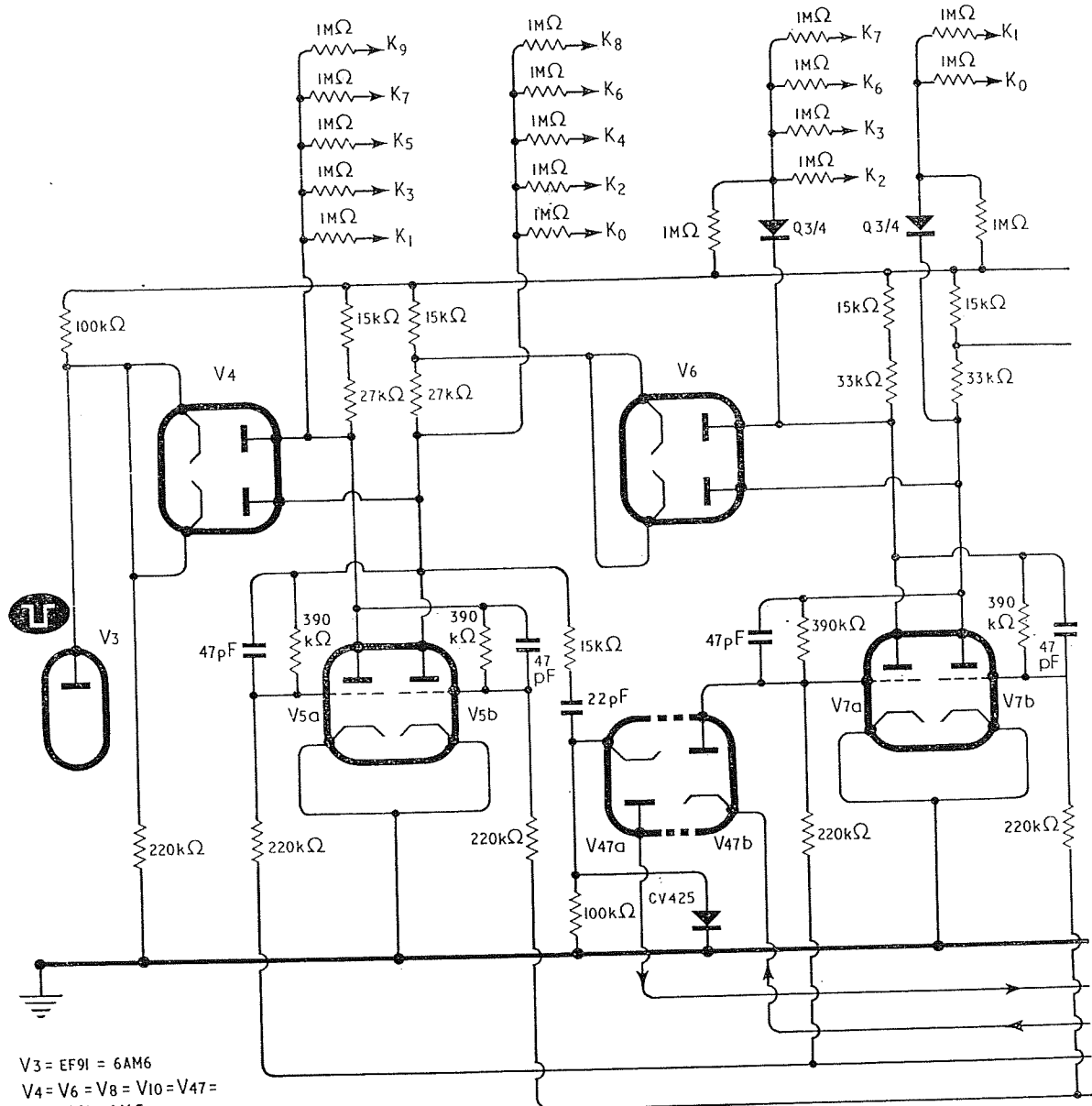

V3 = EF91 = 6AM6
 V4 = V6 = V8 = V10 = V47 =
 EB91 = 6AL5
 V5 = V7 = V9 = V11 = 6060 = M8162 = I2AT7 WA
 V12 = GR10A

Fig. 7.5 A valve decade circuit with

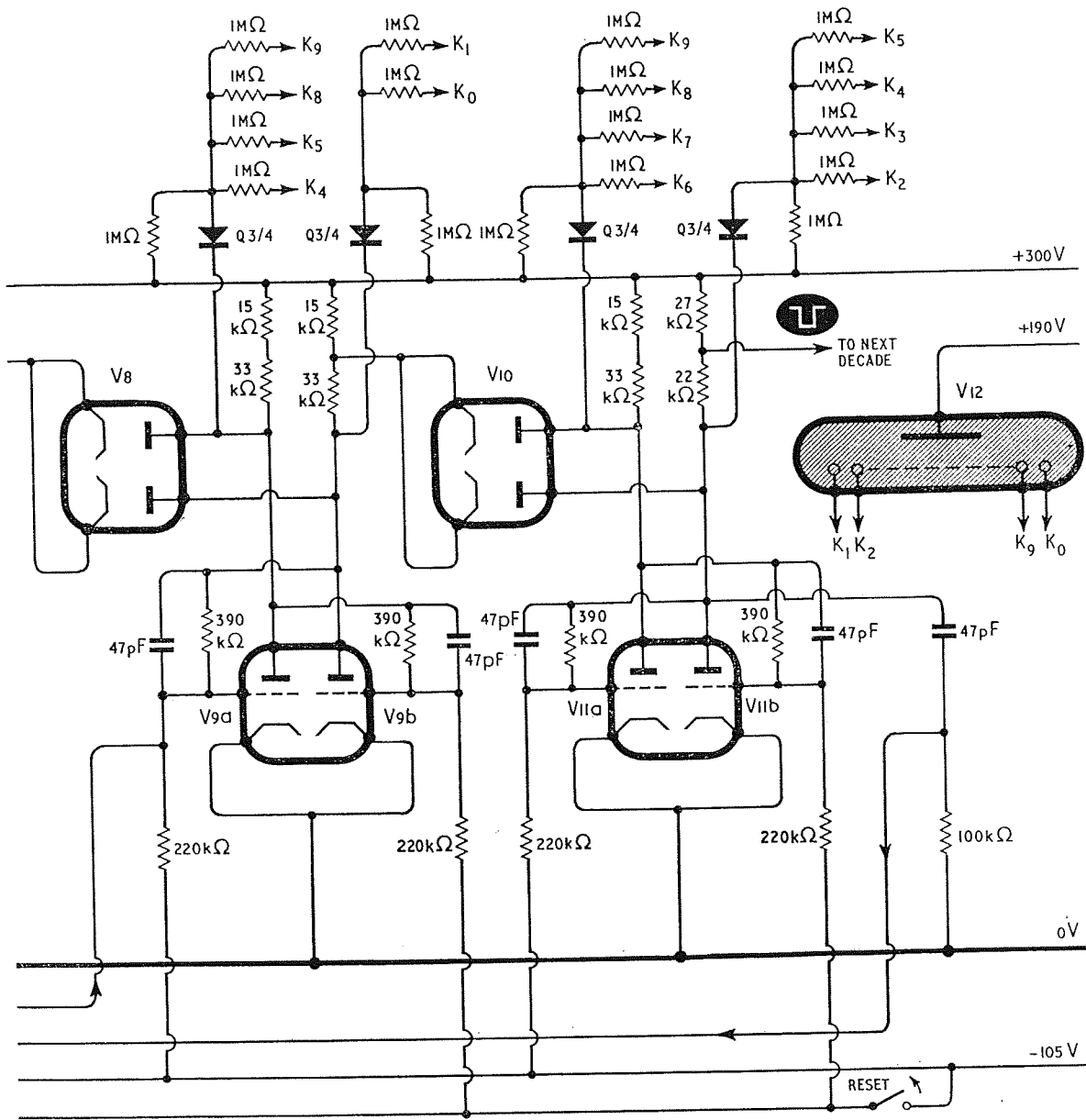

GR10A readout. (Part of Ecko N530F scaler)

ELECTRONIC COUNTING CIRCUITS

Table 7.1 THE TEN STATES OF THE CIRCUIT OF FIG. 7.5

No. of Input Pulses	State of Circuit as a Binary Number	Possible Intermediate States
0	0 0 0 0	
1	0 0 0 1	
2	0 0 1 0	
3	0 0 1 1	
4	0 1 0 0	
5	0 1 0 1	
6	1 0 1 0	(0 1 0 1←) ↑↑↑↑
7	1 0 1 1	
8	1 1 0 0	
9	1 1 0 1	(1 1 0 1←) ↑↑↑↑
10	0 0 0 0	(0 0 1 0) ↑

indicator tube, this cathode will glow only after five pulses have been received. If the connection to *V5a* were omitted, it would also glow after four pulses had been received and the count would be ambiguous. On the other hand, if the connection from the fifth cathode of the indicator tube to *V7b* is omitted, the cathode will glow when the circuit is in the binary states of 5 and 7. The binary state of 7 has been eliminated by feedback, however, so the fifth cathode need only be connected to the other three anodes and a glow will be obtained from it only after five input pulses have been received.

By similar reasoning it can be shown that each cathode of the indicator tube need be connected to only three of the anodes of the tubes in the four binaries. The necessary connections are shown in Fig. 7.5. Except in the case of the first binary stage,

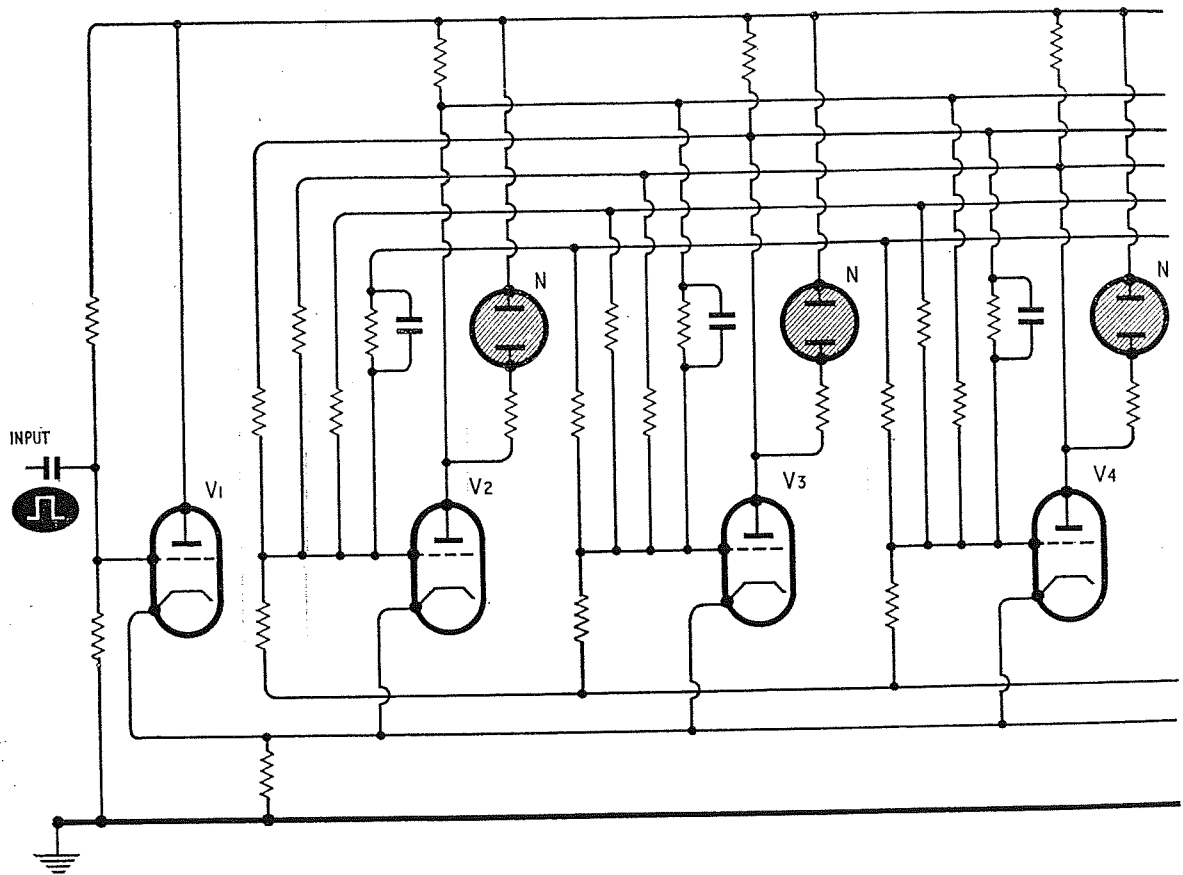
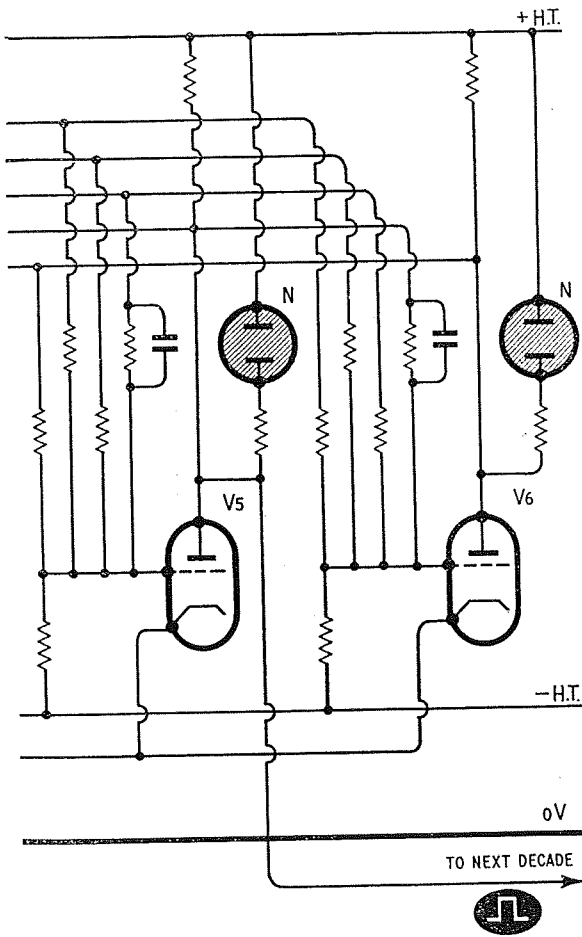

Fig. 7.6 A ring of five hard valves

the anodes of the binaries are connected to the cathodes of the indicator tube via diodes which help to remove any loading and reduce stray glows on the non-conducting cathodes.

In the N530F scaler the decade shown in Fig. 7.5 is followed by a very similar decade, also with GR10A readout, but the forward coupling is effected by means of capacitors instead of diodes, since the maximum speed at which the second decade is required to operate is one tenth of that of the first decade. In addition, longer time constants (larger resistors) are used in the second decade so that the power consumption is smaller.

7.2 VALVE RING COUNTING CIRCUITS



with neon tube readout

It is possible to construct ring circuits using hard valves, but such circuits tend to be very complicated if many stages are required in each ring. The bistable circuit is effectively a ring of two stages. The ring circuit of Fig. 7.6 functions on similar principles, but contains more tubes in the ring. Such a circuit must be arranged so that when one triode conducts all of the others receive a bias which is sufficient to prevent them from passing a current. Suitable forward coupling must also be arranged.

Although the circuit of Fig. 7.6 is not particularly simple, there are only five tubes in the ring. The neons marked *N* provide the readout. The valve *V1* is a cathode follower which provides pulses to the cathodes of all the valves in the ring. If one valve is conducting, the fall of potential at its anode is communicated to the grids of all the other triodes in the ring by means of the potential dividing resistors; this ensures that all of the other valves are cut off. The grid of the conducting valve is connected to the anodes of the non-conducting valves which are at the potential of the H.T. line. Thus when any one valve conducts, the state of the circuit is a stable one.

Positive going pulses applied at the input pass through *V1* and the common cathode potential of all the valves is raised. The valve which was previously conducting is thus cut off. The grid potentials of the other valves are thereby raised, but they do not conduct owing to the high common cathode potential. The resistor connecting the anode of one valve to the grid of the succeeding valve is, however, bridged by a capacitor and for a short time the full positive pulse at the anode of the valve which has been cut off is passed to the grid of the succeeding valve which conducts in spite of its high cathode potential. The anode to grid connections ensure that once a valve has commenced to conduct, it will conduct until another input pulse cuts it off.

When *V6* is conducting the circuit is in its zero state. If *V5* is conducting and an additional input pulse is received, the potential of the anode of *V5* will rise as the valve is cut off; this positive going pulse can be used to operate the next ring of valves. The ring may be reset by the application of a positive going pulse to the grid of *V6*.

Ring circuits using triodes can operate at mode-

rately high frequencies (up to about 100 kc/s), but in practice the number of stages which can be incorporated in each ring is very limited. In Fig. 7.6 a resistor is employed to connect the anode of each valve to the grid of every other valve. If the number of stages is increased to twelve, 132 anode to grid resistors will be required. Apart from the resulting circuit complexity, such arrangements do not function satisfactorily owing to the excessive loading imposed on each anode circuit by the potential dividing resistors and the consequent reduction of gain in the feedback loop. A ring containing more than about seven valves is, most difficult to design.

Valve ring circuits can also be designed with one valve cut off and the remainder conducting. The current consumption and hence the heat dissipated is greatly increased, but more current is available for switching the valves. In large rings oscillations can occur in which each valve conducts in turn.

7.2.1 Ring of Bistable Circuits

Although a single high vacuum valve does not exhibit two characteristic stable states, valves may be used in pairs in multivibrator bistable circuits, each pair of valves being used as one element of the ring.

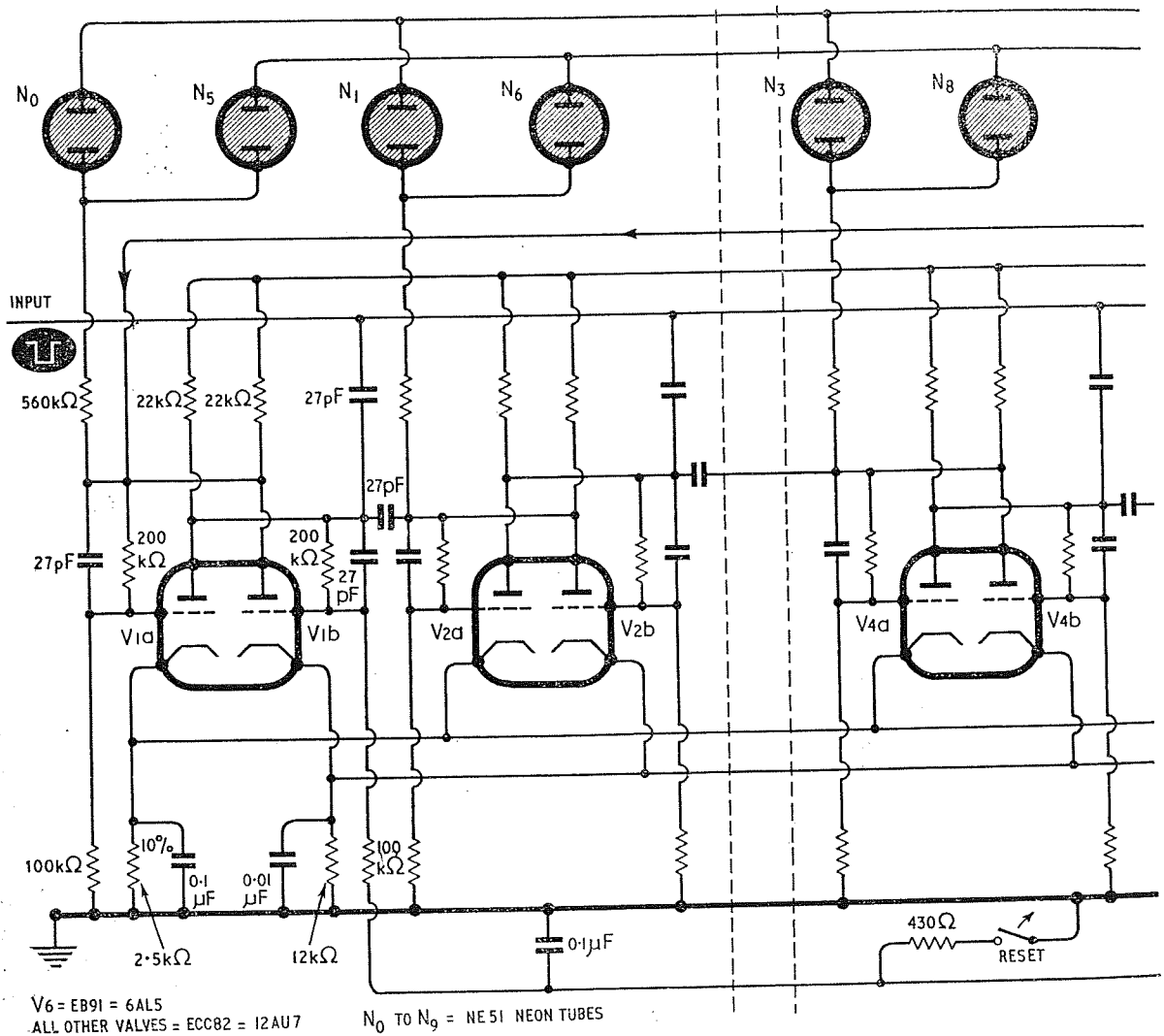

Fig. 7.7 A decade circuit comprising six multivibrators. (Values unmarked)

Such a ring may contain any number of bistable circuits, but the number of valves required is twice the number of states in the ring.

The decade circuit of Fig. 7.7⁽⁶⁾ consists of a ring of five bistable circuits ($V1$ to $V5$) followed by a single bistable circuit ($V7$). A decade can thus be constructed using a total of six multivibrators, whereas if a ring of ten is employed, ten multivibrators would be required. The maximum operating frequency of the circuit shown is about 200 kc/s. The output pulses are suitable for the direct operation of a similar succeeding decade.

The negative going input pulses are applied to the anodes of the left-hand triodes of the ring of

five via the capacitors connected to the input line and are coupled to the grids of the right-hand triodes via the capacitors and resistors. At any one time one of the five right-hand triodes $V1$ to $V5$ is conducting; let us assume that it is $V2b$. An input pulse will result in $V2b$ being cut off and $V2$ being switched to its quiescent state. The resulting negative going pulse at the anode of $V2a$ passes through the coupling capacitor and cuts off $V3a$; $V3$ is thus switched to indicate a count. The negative going input pulses are fed to the grids of all the right-hand triodes, but have no effect on the tubes which are cut off. The input pulses are also coupled to the grids of the conducting left-hand triodes, but are atte-

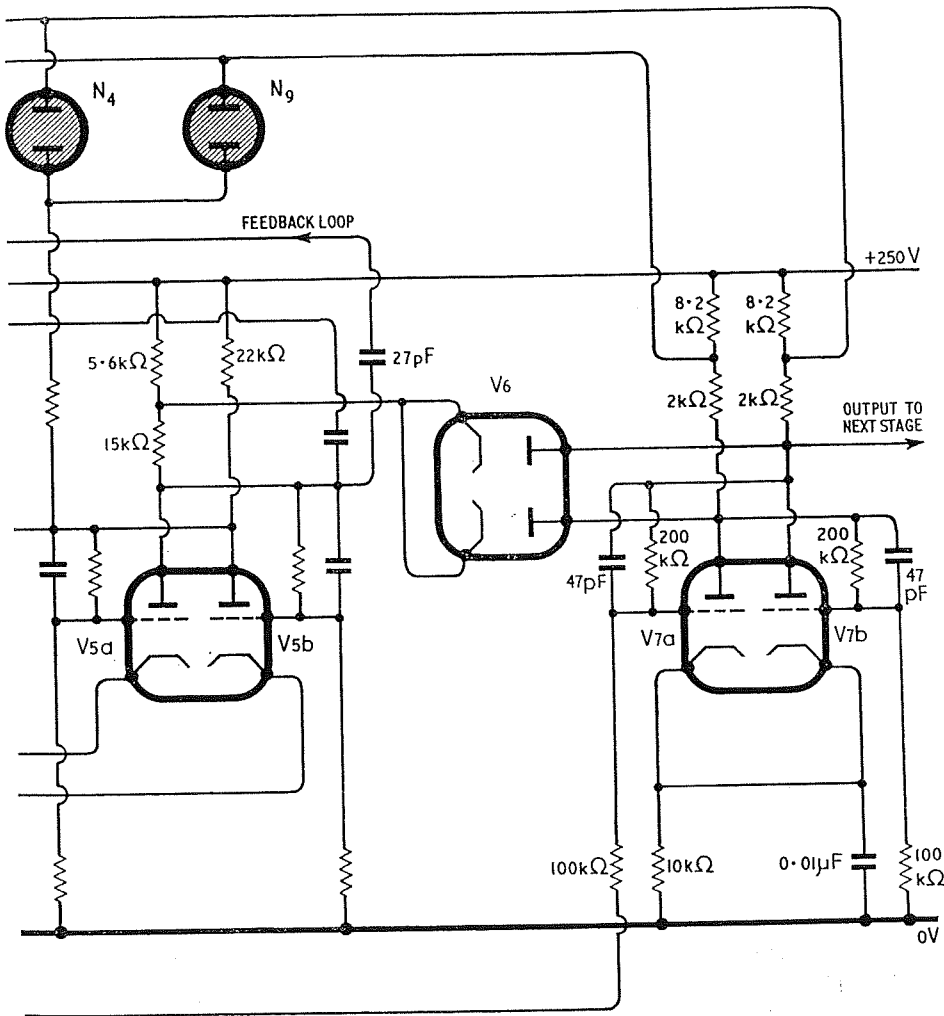

are the same as those surrounding V_1)

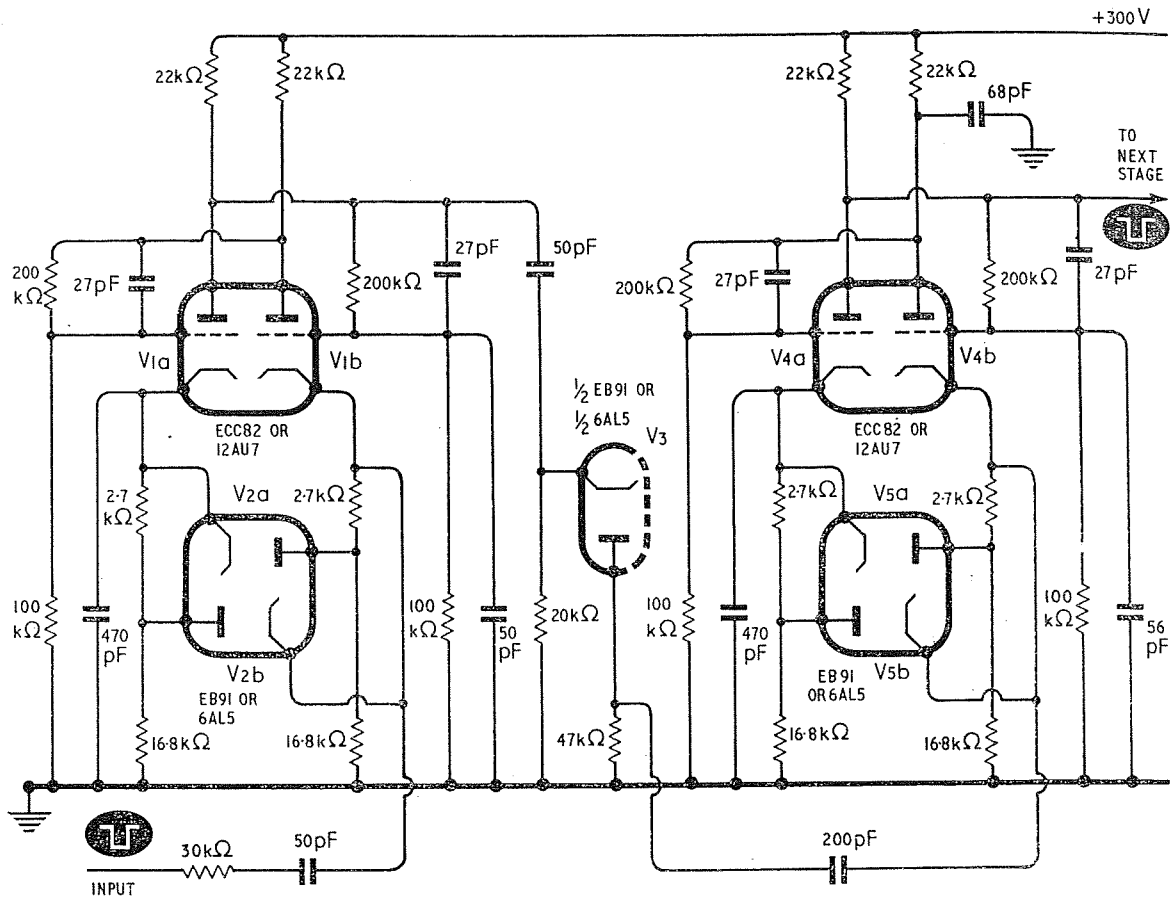

Fig. 7.8 Two cascaded ternary circuits

nuated so much by the coupling components in series with the grid resistance of the valve (which is taking grid current) that they produce no effect at all.

When $V5a$ is cut off, a positive pulse occurs at its anode, but cannot pass through $V6$. If $V5a$ is now switched back to its quiescent conducting state, the resulting negative going pulse passes through $V6$ to whichever anode of $V7$ is not passing a current. $V7$ thus changes its state each time $V5$ is returned to its zero state. A neon tube will glow only when the anode of $V7$ to which it is connected is cut off and when the right-hand valve of the multivibrator in the ring of five to which it is connected is conducting. During the first four pulses $V7a$ conducts and successive pulses will transfer the glow from N_0 to N_4 . During the next five pulses $V7b$ conducts and the neons N_5 to N_9 will glow in succession. A tenth pulse resets the circuit to zero. A neon will strike

when the potential difference across it is about 90 V. The anode potential of the valves in the ring varies from about 130 V (conduction) to 250 V. The voltage applied to the neons from the tapping on the anode resistor of the conducting triode of $V7$ is about 195 V.

The output taken from $V7b$ will consist of one negative pulse for each ten input pulses. The reset circuit must reset both the ring of five and the bistable circuit of $V7$.

7.2.2 Valve Ternary Circuit

Ternary circuits operate on the scale of three, the only digits used being 0, 1 and 2. Circuits which operate on the scale of three can be constructed using two cascaded multivibrators with suitable feedback to reduce the scale of four to a scale of

three or by using a ring of three trigger tubes or other, bistable devices. The name 'ternary' is, however, normally used only to refer to circuits which have three stable states per stage. Such a circuit can be constructed by modifying a valve bistable multivibrator. In addition to the normal two states in which one of the two tubes is fully conducting, a third state can be introduced in which both tubes pass a limited amount of current. Such circuits have the advantage over valve binary stages that fewer tubes are required to count over a given scale. For example, six cascaded ternary stages count in a scale of 729, whilst six binaries count in a scale of 64.

Two cascaded ternary circuits are shown in Fig. 7.8⁽⁷⁾. The first ternary circuit consists of $V1$ and $V2$. This circuit is in the zero state when $V1a$ is fully conducting and $V1b$ is cut off. The flow of current through the cathode resistor of $V1a$ results in the diode $V2a$ being in its non-conducting state. $V2b$ conducts, however, since the flow of current through the cathode resistor of $V1a$ renders the anode of $V2b$ positive with respect to its cathode; the lower part of the cathode resistor of $V1a$ (that is, $16.8\text{ k}\Omega$) is, therefore, effectively in parallel with the cathode resistor of $V1b$.

When a negative pulse is applied to the cathode of $V1b$, this valve conducts and the normal switching operation of a multivibrator commences. When both triodes are conducting, the diodes $V2$ are cut off, since the cathodes of the diodes receive the full positive voltage developed across the cathode resistors. The full values of the triode cathode resistors therefore become effective and the gain of both triode stages falls to a value at which the switching conditions of the bistable circuit are no longer satisfied (that is, the loop gain is less than unity). Both triodes, therefore, remain conducting

with an anode current at a moderate value. This is the state after one input pulse.

A second input pulse increases the current in $V1b$ so that the diode $V2a$ conducts. The effective value of the cathode resistor of $V1b$ is now reduced and the stage can switch into the state in which $V1a$ is blocked and $V1b$ is fully conducting.

The third input pulse applied to the $V1b$ cathode causes this tube to take grid current and the grid voltage to fall. The capacitors in the grid circuit of $V1b$ charge during the pulse and keep the grid voltage strongly negative with respect to the cathode for a short time after the end of the pulse. $V1b$ is therefore cut off and the multivibrator switches to its zero state. The negative going pulse at the anode of $V1a$ passes through the diode $V3$ and triggers the next ternary stage, $V4$.

Readout from the ternary circuit may be obtained by connecting one neon in series with a $1\text{ M}\Omega$ resistor between the anodes of the two valves in each stage. The left-hand electrode of the neon will glow in the zero state, neither electrode will glow after the first pulse and the right-hand electrode will glow after two pulses. For ease of readout it is normally preferable to use two neons per stage so that it is not necessary to observe which electrode is glowing. A neon in series with a resistor may be connected from each anode to a supply of $+235\text{ V}$.

The negative going input pulses to the ternary circuit should have an amplitude of between 85 and 150 V and a duration greater than $1\text{ }\mu\text{sec}$. The three states are well defined at anode potentials of 135 , 190 and 255 V . The circuit requires about 8 mA per stage at 300 V , but will operate at H.T. supply potentials from 250 to 325 V .

Other valve circuits have been designed for counting at frequencies up to 10 Mc/s ⁽⁸⁾ and for reversible counting⁽⁹⁾.

REFERENCES

1. W. H. ECCLES & F. W. JORDAN, *Radio Review*, **1**, 143 (1919).
2. P. NEETESON, *Vacuum Valves in Pulse Technique*, 2nd Ed. Philips Technical Library, (1959).
3. 'Instruction Manual for Scalers type 1009E', A.E.R.E., Harwell.
4. F. W. LOVICK, 'A Dekatron 'add-on' unit', *Electron. Eng.* **30**, 16, (1958).
5. Automatic Scaler Type N530F. Technical Instructions, Ecko Electronics Ltd.
6. R. WEISSMAN, 'Stable ten-light decade scaler', *Electronics*, **22**, 84 (1949).
7. R. WEISSMAN, 'High speed counter uses ternary notion', *Electronics*, **25**, 118 (1952).
8. D. E. COTTRELL, 'Binary-decimal counter operates at 10 Mc/s ', *Electronics*, **30**, 186 (1957).
9. H. J. WEBER, 'Binary circuits count backwards or forwards', *Electronics*, **32**, 82 (1959).

Solid State Scaling Circuits

The circuits described in this section which use binary stages are in their zero state when the right-hand transistor of each binary is conducting.

Modern solid state scaling circuits can be designed for extremely high speed operation, consume little power and are ideally suited for use as miniature printed circuits. They, therefore, possess most of the advantages which are required for use in fast computers and in many other applications; this explains the vast interest in them at the present time.

8.1 TRANSISTOR SCALERS

A single junction transistor, like a hard valve, does not have two characteristic stable states, but a bistable circuit may be constructed by using two junction transistors. Most transistor scalers consist of sets of four cascaded bistable circuits with feedback to reduce the scale of sixteen to a scale of ten. At the moment transistor ring circuits are not so common.

A single point contact transistor (the first type of transistor to be discovered) can be used in a bistable circuit, since in a common base circuit it can have a current gain which is greater than unity without phase reversal. Although this type of transistor is suitable for use in ring circuits, very few types of point contact transistor are now available, since their reliability is poor and the spread of characteristics from transistor to transistor of the same type is large. Only junction transistors will, therefore, be considered in this chapter.

Junction transistors are, on the whole, excellent devices for use as switches. An ideal switch would

have an infinite resistance when open and a zero resistance when closed. When a transistor is switched off (that is, both of the junctions are reverse biased), the collector to emitter impedance will be measured in megohms and only a small 'leakage' current flows. When both junctions of the transistor are forward biased, a large current passes and the transistor is said to be saturated (that is, saturated with current). In this state the impedance from the collector to the emitter is only a few ohms and almost all of the collector supply voltage is dropped across the collector load resistor. Under these conditions the potential of the collector with respect to the emitter is about 0.1 V, but falls somewhat with increasing base current until the latter becomes so large that it develops an appreciable voltage drop across the internal emitter resistance. Bottoming occurs when the operating point is below the knee of the collector current/collector voltage characteristic and is approximately the same as saturation. An increase in the base current of a bottomed transistor will not lead to an appreciable increase in the collector current, since in the bottomed state the collector current is almost entirely determined by the collector load and the supply voltage.

The operating point of a transistor which is being employed as a switch moves over a large part of the characteristic curve and, therefore (as in the case of valve switching circuits), the simple small signal equivalent circuits cannot be used, but more comp-

licated large signal equivalent circuits lead to good approximations to the actual behaviour^(1, 2). Most transistor bistable circuits are designed, to some extent, on a trial and error basis, since a full mathematical analysis of a switching circuit (especially a non-saturating circuit) requires a considerable effort and involves certain approximations.

Transistors employed in counting circuits are normally required to have a high maximum operating speed. This implies that they must have a high cut off frequency, since the maximum switching speed is dependent on the cut off frequency. It is also desirable that they should have a low bottoming voltage if saturated circuitry is being employed, a low leakage current and a high gain over a large part of their characteristic.

The change in the collector voltage which occurs when a transistor is switched to the conducting state takes place more rapidly than when the transistor is switched to the cut off state. If a positive going pulse is applied to the base of a saturated PNP transistor, the collector current will flow for a few microseconds before the input pulse succeeds in cutting off the transistor. This occurs because more minority carriers (holes in the case of PNP transistors) are fed from the emitter into the base region during saturation than are required to enable the collector current to flow. Owing to the forward bias of the collector-base junction, the collector will become an emitter and some carriers will return from the collector to the base. The surplus minority carriers are stored in the base region (and, in some types of transistor, also in the collector region) and are used to prolong the flow of collector current for a short time after the emitter current has been cut off.

In order to obtain higher operating speeds, the storage of minority carriers may be avoided by the use of transistors in non-saturating circuits where bottoming does not occur. This does, however, complicate the circuitry, leads to greater power dissipation in the transistors and results in smaller available output currents and less well defined voltage states. In addition the use of non-saturating circuits tends to reduce reliability somewhat⁽³⁾, since bottomed circuits are unaffected by short stray pulses.

A special system of charge control transistor parameters has been proposed for switching circuits⁽⁴⁻⁸⁾ in which the transistor is considered to be switched to the conducting state by the removal of a certain amount of charge from the base region. This takes a finite time and the charge control parameters are, therefore, useful for calculating the rise and fall times in any circuit. If they are known for one circuit, they may be calculated for any other which employs the same transistors. The expression for the delay which occurs when a bottomed transistor is cut off contains two terms one of which is associated with the transistor itself and the other with the circuit in which it is being used^(1, 9, 10). The transistor term can be measured directly⁽¹¹⁾.

8.1.1 Types of Bistable Circuit

The common types of bistable circuit in which only one of the two transistors is conducting in the quiescent state at any one time can be classified

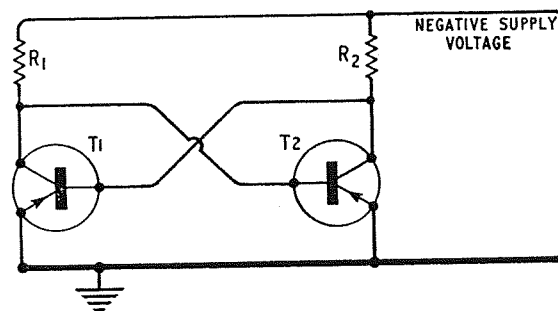

Fig. 8.1 A direct coupled multivibrator

according to the type of coupling employed, according to whether the conducting transistor is allowed to bottom or not and whether the circuit is symmetrical with respect to the two transistors. In complementary symmetry circuits both transistors conduct simultaneously. Some common types of bistable circuit will be discussed, but many variations are possible.

The simplest form of coupling between two transistors is a direct coupling from the collector of each transistor to the base of the other as shown in Fig. 8.1. This type of circuit is known as 'Direct Coupled Transistor Logic' (DCTL) and is employed only in saturated circuits.

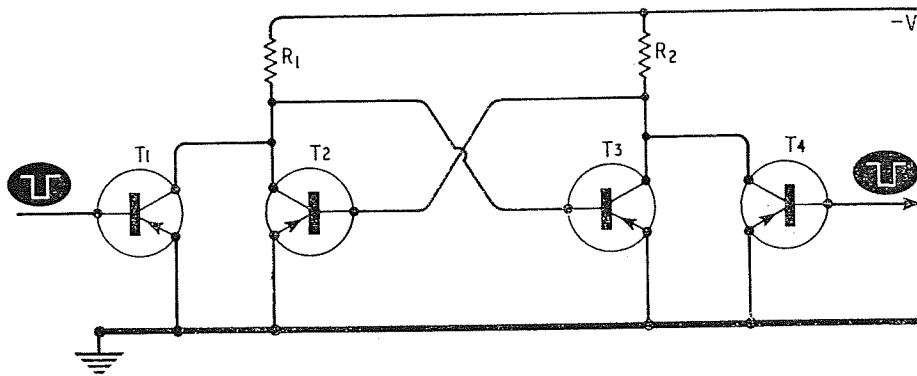

Fig. 8.2 A direct coupled binary circuit with triggering transistors

If the right-hand transistor, T_2 , is bottomed, T_1 will pass little current. Almost the whole of the current passing through R_1 flows in the base of T_2 which is thus kept in a highly saturated condition. In this type of circuit the collector to emitter voltage of the conducting transistor must be so small that it may be applied to the base of the other transistor without causing the latter to pass very much current.

The circuit may be switched by momentarily reducing the base current of the conducting transistor to zero so that its collector current is cut off. Two additional triggering transistors are usually used for this purpose as shown in Fig. 8.2. The

additional transistors, T_1 and T_4 , are normally in the non-conducting state. If T_2 is conducting and T_3 non-conducting, a negative pulse applied to the base of T_4 will allow this transistor to conduct for a moment and take the current from R_2 which was previously passing to the base of T_2 . Thus T_2 is cut off and a current commences to flow through R_1 and the base of T_3 . The circuit is thus switched.

A practical binary circuit using this type of coupling is shown in Fig. 8.3⁽¹²⁾. The capacitors C_1 and C_2 are charged to the collector potentials of the transistors. Negative input pulses applied to the base of T_5 will cause this transistor to conduct and hence

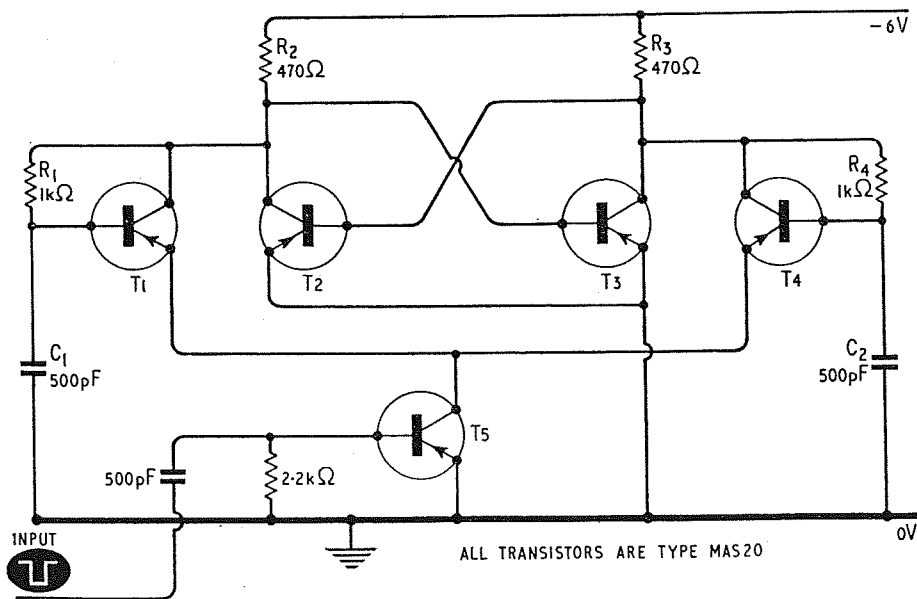

Fig. 8.3 A practical DCTL binary circuit

the emitters of T_1 and T_4 will effectively be earthed. If T_2 is conducting, T_4 will conduct during the pulse owing to its negative collector potential. The base current ceases in T_2 with the result that the binary changes its state. The values of C_1 and C_2 must be large enough to hold the bases of T_1 and T_4 at a steady potential during the switching operation, but if they are too large in value, the resolving time will be increased. The circuit shown has a maximum frequency of about 2.5 Mc/s and the power dissipated in each transistor is about 5 mW.

In direct coupled circuits the conducting transistor must heavily saturate so that the base current is nearly equal to the collector current. The speed of operation is therefore limited, since a heavily saturated transistor has a relatively large stored charge in the base region. The voltage ratings of the transistors may be small, since the voltage swings

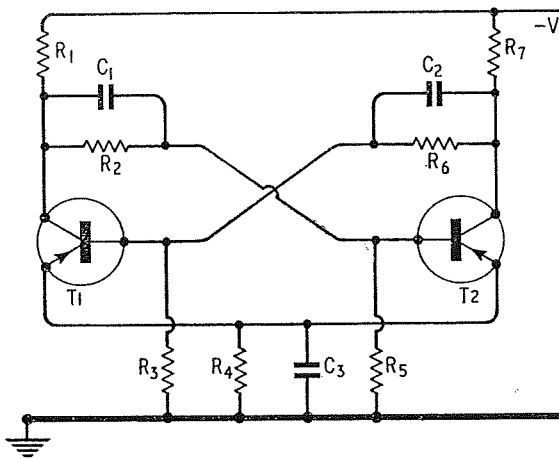

Fig. 8.4 A RCTL bistable circuit

are small. The circuit has the disadvantages that it is very susceptible to stray pulses owing to the small voltage changes and, if germanium transistors are employed, the temperature range for satisfactory operation is somewhat limited.

Greater voltage swings can be obtained if resistors are used to couple the transistors. This system is known as 'Resistor Transistor Logic'⁽¹³⁾ (RTL). The resulting circuit is inherently rather slow in operation, since the base capacity of the transistors takes time to charge through the coupling resistors. The circuit may, however, be speeded up by the

addition of a capacitor across each of the coupling resistors as shown in Fig. 8.4. This type of circuit is the fastest and most common type of saturating transistor binary stage; it is known as 'Resistor Capacitor Transistor Logic' (RCTL). The coupling capacitors, C_1 and C_2 , and resistors, R_2 and R_6 , should have a time constant which is about the same as the time constant of the transistor input impedance. The amount of feedback is then independent of frequency and the high frequency components of a steep waveform can pass from the collector of one transistor to the base of the other without the waveform being appreciably distorted. The capacitor may be regarded as supplying the charge necessary to cut the transistor off.

The emitters of the transistors are returned to earth via R_4 . The bias voltage developed across this resistor must be great enough to ensure that one of the transistors is completely cut off. C_3 is chosen so that the potential across R_4 is kept fairly constant during switching. The potential dividers formed by R_2 and R_5 and by R_6 and R_3 can be chosen so that the base current to the conducting transistor is limited in order to avoid heavy saturation and the consequent frequency limitations.

If PNP transistors are employed, positive going input pulses are normally used to cut off the conducting transistor, since only small positive pulses are required to overcome the small negative base to emitter voltage of a conducting transistor. If negative pulses are used to switch a non-conducting PNP transistor, however, much larger input pulses are required, since the base of a cut off transistor is receiving an appreciable positive bias. The input pulses are normally applied to the bases, but they may be applied to the collectors (as in Figs. 8.9 and 8.10), in which case a pulse of larger amplitude is required.

As in valve scalars, diode gates are normally employed to guide the input pulses alternately to each transistor. Fig. 8.5 shows a practical binary with diode gates D_1 and D_2 in which the input pulses are fed to the transistor bases⁽¹²⁾. If T_1 is conducting, the collector potential will be little different from the emitter or base potentials. There is therefore little potential difference across the diode D_1 and any positive going input pulse will render D_1 conducting so that the pulse can pass to T_1 to switch the stage.

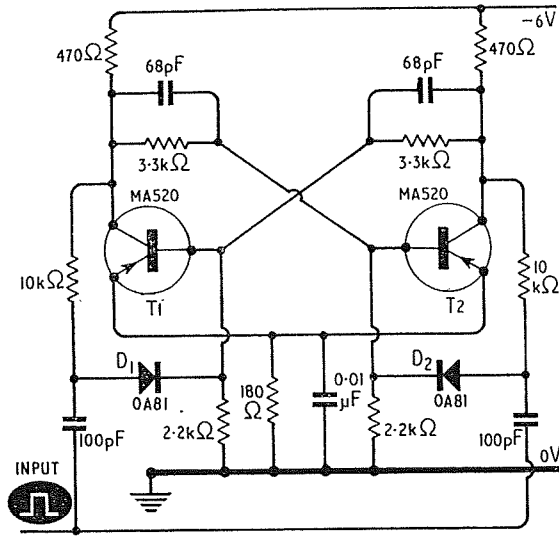

Fig. 8.5 A practical RCTL bistable circuit

The negative potential of the collector of T_2 during the time this transistor is cut off ensures that D_2 is reverse biased; the positive input pulse cannot, therefore, pass through D_2 unless it has an amplitude which is great enough to overcome the reverse bias of the diode. The input pulses should not, therefore, be too large. When the stage has switched the transistors will interchange roles and D_1 will now be reverse biased so that the succeeding input pulse is gated to T_2 only. This circuit will operate reliably at 4 Mc/s and will function with a supply voltage as low as 3 V.

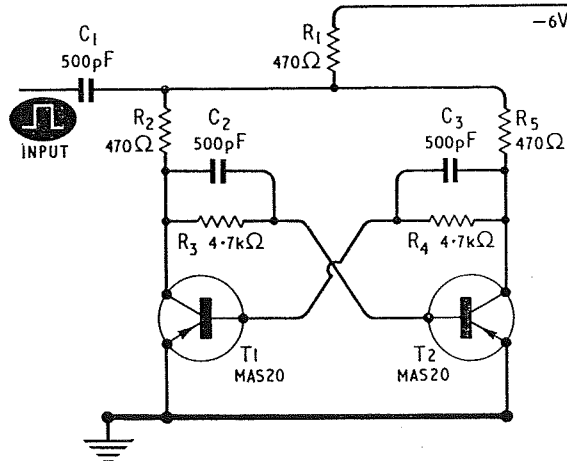

Fig. 8.6 An economical binary circuit

If the maximum operating speed is reduced, it is possible to omit the gating diodes when suitable transistors are used. An economy circuit of this type is shown in Fig. 8.6⁽¹²⁾. The base of each transistor is not returned to earth through a resistor and therefore the collector to emitter voltage of a saturated transistor must be so low that it does not cause the other transistor to pass appreciable current. If T_1 is conducting, the positive going input pulse will pass through R_5 and R_4-C_3 to the base of T_1 which is thus cut off. The pulse does not appreciably affect the collector potential of the conducting transistor, T_1 , and therefore does not reach the base of the non-conducting transistor, T_2 . The input is shunted by

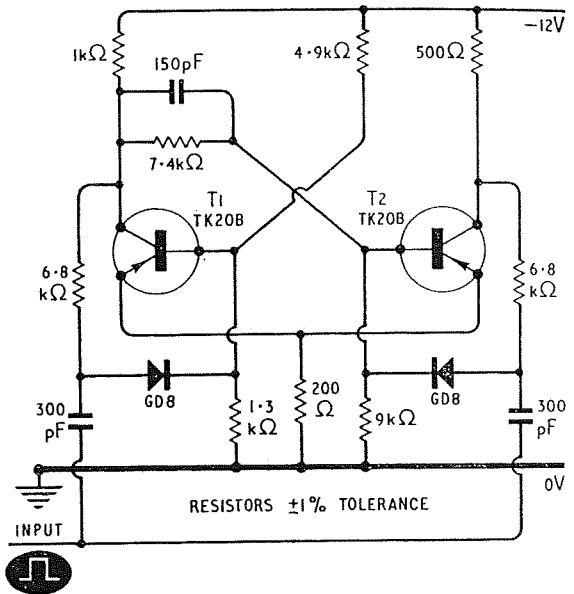

Fig. 8.7 An asymmetrical binary circuit

the resistor R_1 and by the collector load of the conducting transistor, so that sensitivity is rather low. The circuit will function at frequencies up to 1 Mc/s and requires an input pulse amplitude of about 1 V.

Asymmetrical Bistable Circuit

The common emitter resistor of Fig. 8.4 can be used to provide the feedback from one transistor to the other if the by-passing capacitor C_3 is removed. A saturating bistable circuit of this type is shown in Fig. 8.7⁽¹⁴⁾. T_2 is a common collector amplifier and T_1 a common base amplifier; the output from T_1 is

coupled to T_2 . Owing to the asymmetry of the circuit, the outputs from the transistors differ in amplitude. The power consumed varies from 144 mW when T_1 conducts to 240 mW when T_2 conducts.

If a bistable circuit is to be operated with heavy loading on its output, it may be advantageous to employ two emitter followers to couple the output of each transistor to the input of the other ⁽¹⁴⁾.

Complementary Symmetry Circuits

Complementary symmetry circuits ⁽¹⁵⁾ employ one PNP and one NPN transistor. At any time either both transistors are conducting or both are cut off. The basic type of bistable circuit which they are used in shown in Fig. 8.8. The whole of the collector current of each transistor is fed to the base of the

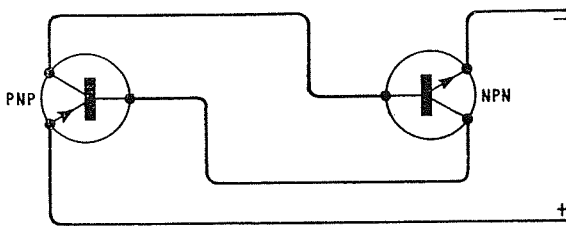

Fig. 8.8 The basic complementary symmetry bistable circuit

other. Fewer components are used than in the common types of bistable circuit and little power will be consumed if the circuit is in its non-conducting state for the majority of its operating time. The two transistors together behave as a transistor with a common base circuit gain greater than unity and can be used to replace a single point contact transistor in ring circuits, etc., such as that of Fig. 8.18. Saturated complementary symmetry circuits have been designed for use at frequencies of up to 20 Mc/s ⁽¹⁶⁾. A single PNP device is effectively the same as the two transistors of Fig. 8.8 and can be used in the same type of bistable circuits (Section 8.2).

Non-saturating Circuits

In order to obtain faster switching or greater sensitivity to input pulses, a bistable circuit may be arranged so that the transistors do not operate in the saturated condition. There are a number of ways in which saturation may be prevented, but in all of

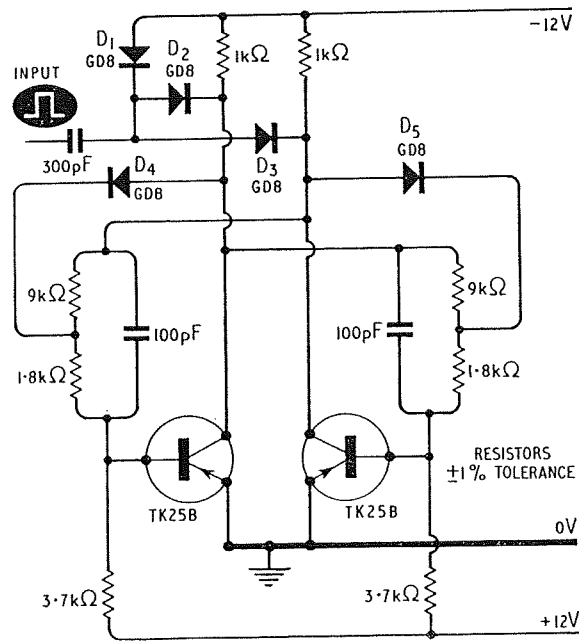

Fig. 8.9 The use of feedback to avoid saturation

them care must be taken to ensure that the power dissipated in the conducting transistor does not become excessive.

It has already been stated that saturation may be prevented in the circuit of Fig. 8.4 by a suitable choice of resistor values which reduce the base current taken by the conducting transistor. Such circuits are not very tolerant of variations in transistor current gain and in order to achieve d.c. stability with transistors of low current gain, it is often necessary to accept some saturation with transistors of the same type but which have a high current gain ⁽¹⁴⁾. Close tolerance resistors are desirable for this type of circuit.

In another type of circuit for avoiding saturation, the fall in potential at a collector as it approaches saturation is fed back to the base so that the collector current is decreased. A typical circuit is shown in Fig. 8.9 ⁽¹⁴⁾. The feedback occurs through either D_4 or D_5 and the circuit is arranged so that these diodes do not conduct until the potential of the collector falls below the potential of the tapping on the coupling resistor. Thus the feedback only takes place as saturation is approached. In this circuit the input pulses are fed to the collector of the conducting transistor via the gating diodes D_2 and D_3 . D_1 clamps

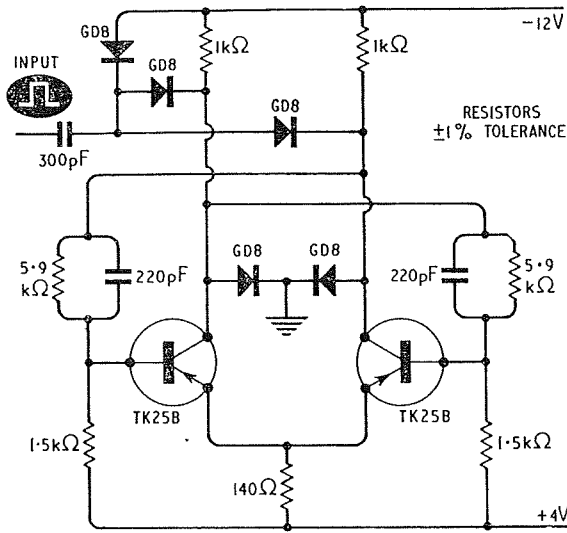

Fig. 8.10 The use of clamping diodes to avoid saturation

the left-hand sides of D_2 and D_3 to the negative supply voltage. This type of circuit has the advantage that the power dissipated at the collectors is small, since the collector current does not rise above the value which is required for bottoming. One of the disadvantages of the circuit is that the output impedance is relatively large. The maximum frequency of operation of the particular circuit shown is about 500 kc/s.

A third method for avoiding saturation involves the clamping of the collector potential by means of

a diode so that it can never reach the bottoming value. The diode used should have a low minority carrier storage and a low forward resistance; a bonded diode maybe suitable. In this type of circuit a large current may pass through the diode and transistor, but this can be avoided by the use of a second diode and a resistor in the emitter circuit. In the circuit of Fig. 8.10, the base-emitter junction of the non-conducting transistor is used as the second diode⁽¹⁴⁾. The circuit is relatively independent of the transistor characteristics. In the particular circuit shown, the power dissipation is about 250 mW and the maximum operating frequency about 600 kc/s.

8.1.2 Decade Circuits

Transistor decade circuits may be constructed by applying feedback to four cascaded binary circuits according to the principles discussed in Chapter 1. The feedback system used will depend on the type of readout being employed and possibly on the operating frequency required. The maximum operating frequency of conventional decade circuits is usually a little above half the maximum operating frequency of the binaries used.

The economical decade circuit of Fig. 8.11(a)⁽¹²⁾ may be constructed from binary circuits of the type shown in Fig. 8.6. The circuit operates as a cascaded binary counter for the first nine pulses, the pos-

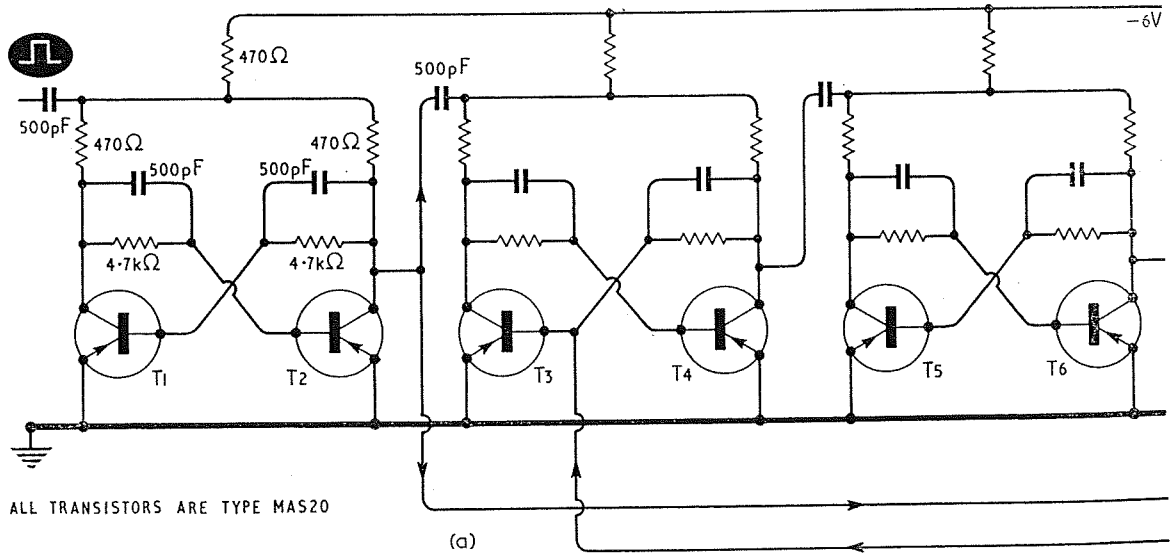

Fig. 8.11(a) An economical decade circuit. (b) An amplifier

itive output pulses from a binary passing through the coupling capacitor to the succeeding binary. $T7$ is cut off during the first seven pulses and is not affected by positive going pulses from $T2$. The fourth binary is switched by the eighth input pulse, whilst the ninth pulse merely switches the first binary. The tenth pulse returns the first binary to zero and a positive pulse from $T2$ passes through D_1 to switch the fourth binary back to zero. A positive output pulse from $T8$ is fed back to $T3$ to prevent the switching of the second binary by the pulse from $T2$. Thus the whole decade is returned to zero.

This circuit uses very few components and operates at frequencies of up to about 800 kc/s. The input pulses should have an amplitude of not less than 0.8 V.

One possible method of readout from the circuit of Fig. 8.11(a) involves the use of small tungsten filament lamps⁽¹²⁾. Four circuits of the type shown in Fig. 8.11(b) may be used to provide the readout without imposing an appreciable load on the binaries in the decade. One of the readout circuits is connected to the collector of the right-hand transistor of each binary in the decade. When a binary is switched from zero to indicate a count, the potential of the collector of the right-hand transistor becomes more negative (almost as negative as the power supply line) and this negative pulse can be used to switch on $T1$

of the readout circuit. The current passed by $T1$ switches on $T2$ and the bulb is thus illuminated.

This method of readout is, of course, binary in nature, the four bulbs indicating counts of 1, 2, 4 and 8. When more than one bulb is illuminated, the count is the sum of the numbers indicated by the illuminated bulbs. A similar readout system could be constructed using small neon bulbs, but high voltage silicon transistors would also be needed. Another system of readout can be constructed in which a diode matrix is employed to convert the binary readout to decimal information⁽¹²⁾. The outputs from the matrix may be amplified and used to operate a group of ten filament lamps which provide decade readout.

8.1.3 Meter Readout

The binary circuit of Fig. 8.5 may be used to construct decade counters of the type shown in Fig. 8.12⁽¹²⁾. The absence of heavy saturation enables speeds of about 4 Mc/s to be attained. This circuit employs a different feedback system to that of Fig. 8.11, since it counts only the first seven pulses in a binary manner. The eighth pulse causes the fourth binary ($T8$ and $T9$) to be switched; a negative going pulse from $T9$ is applied to $T10$ and $T5$ and the resulting current pulses are used to switch the second and third binary stages to indicate a count. The

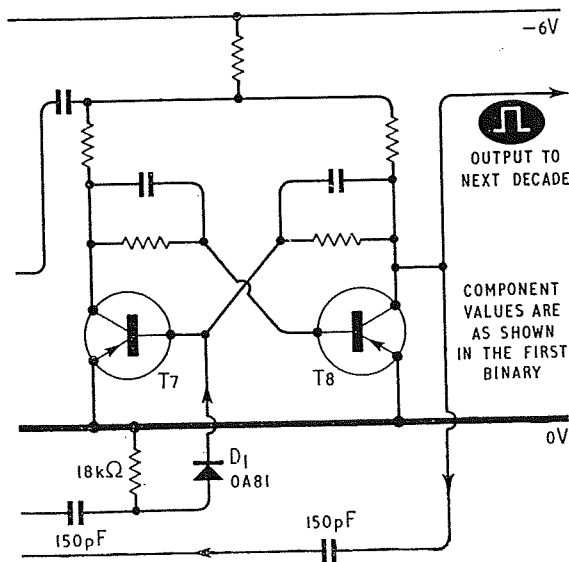

to enable the decade to be used to control indicator lamps

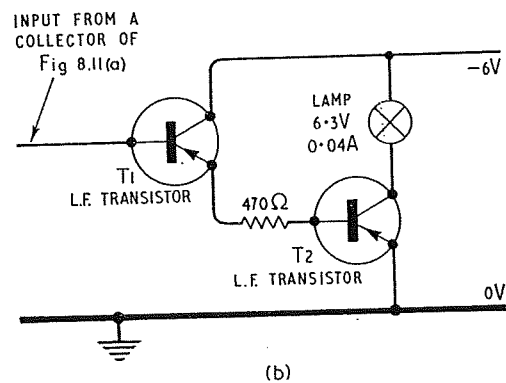

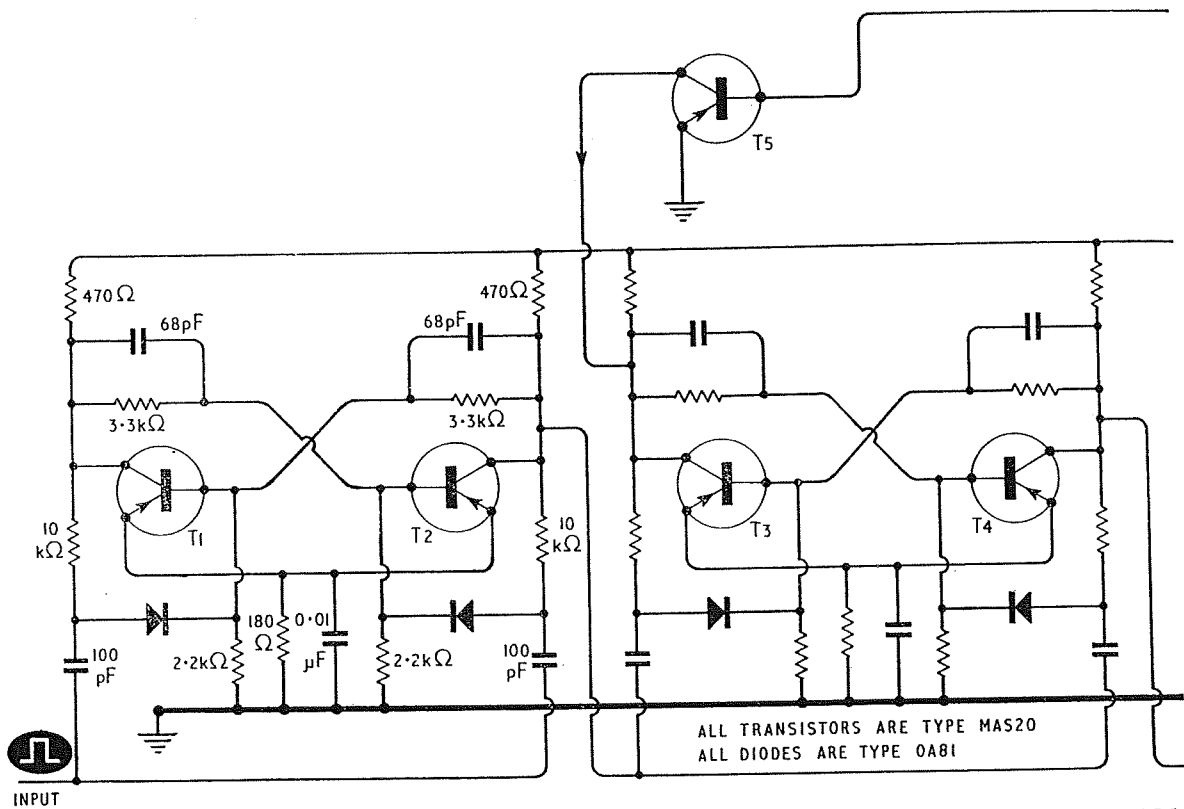

Fig. 8.12 A 4 Mc/s

decade will be switched to zero after another two pulses. The sequence of counting is in Table 8.1. It can be seen that a change of state of the fourth binary should be regarded as being equivalent to two input pulses instead of the more usual eight. The binary numbers 8 to 13 inclusive have been eliminated to convert the scale of 16 to a scale of ten.

This type of feedback system is very suitable for use with the circuit of Fig. 8.13(a) to provide meter readout. Each of the resistors in Fig. 8.13(a) is connected to the collector of the right-hand transistor of one of the binaries. When a binary is in its zero state, the right-hand transistor is bottomed and its collector is at about earth potential. Therefore, little current will pass through the meter to the binary. When a binary is not in the zero state, however, a current will flow through the meter to the collector of the right-hand transistor. This current is almost entirely determined by the resistor shown in Fig. 8.13(a) which is connected to the binary concerned. The current which passes through the resistor $R/4$ to the third binary is four times the current which

passes through the resistor R to the first binary and twice the current which passes through one of the resistors $R/2$ to either the second or fourth binaries when the binaries concerned are not in their zero state. The total current passing through the meter is, therefore, proportional to the number of pulses which have been applied at the input.

Table 8.1

State of binaries	Count
0 0 0 0	$0+0+0+0 = 0$
0 0 0 1	$0+0+0+1 = 1$
0 0 1 0	$0+0+2+0 = 2$
0 0 1 1	$0+0+2+1 = 3$
0 1 0 0	$0+4+0+0 = 4$
0 1 0 1	$0+4+0+1 = 5$
0 1 1 0	$0+4+2+0 = 6$
0 1 1 1	$0+4+2+1 = 7$
1 1 1 0	$2+4+2+0 = 8$
1 1 1 1	$2+4+2+1 = 9$
0 0 0 0	$0+0+0+0 = 0$

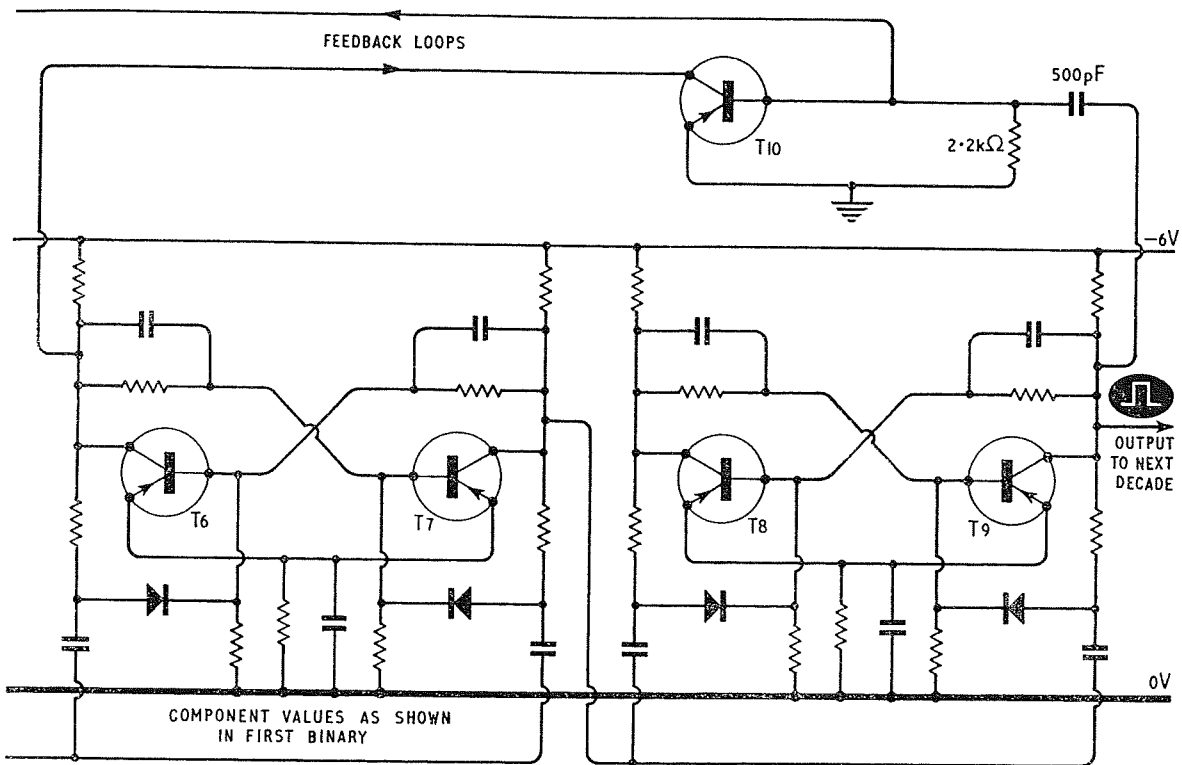

decade circuit

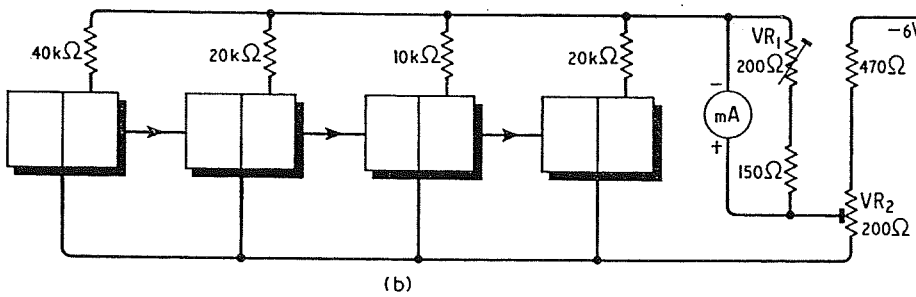
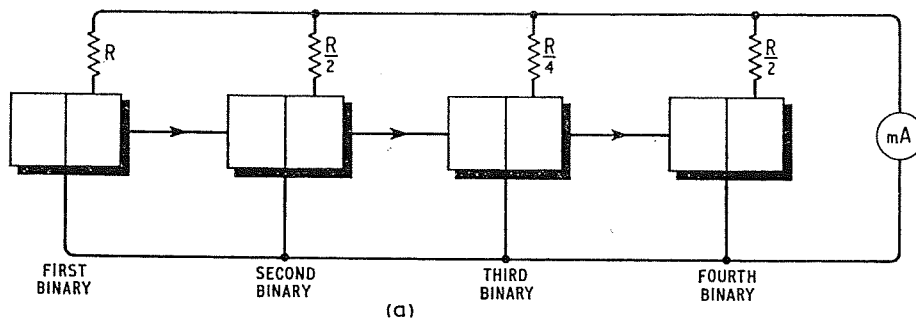

Fig. 8.13(a) The basic circuit for meter readout. (b) Practical circuit for meter readout from Fig. 8.12

ELECTRONIC COUNTING CIRCUITS

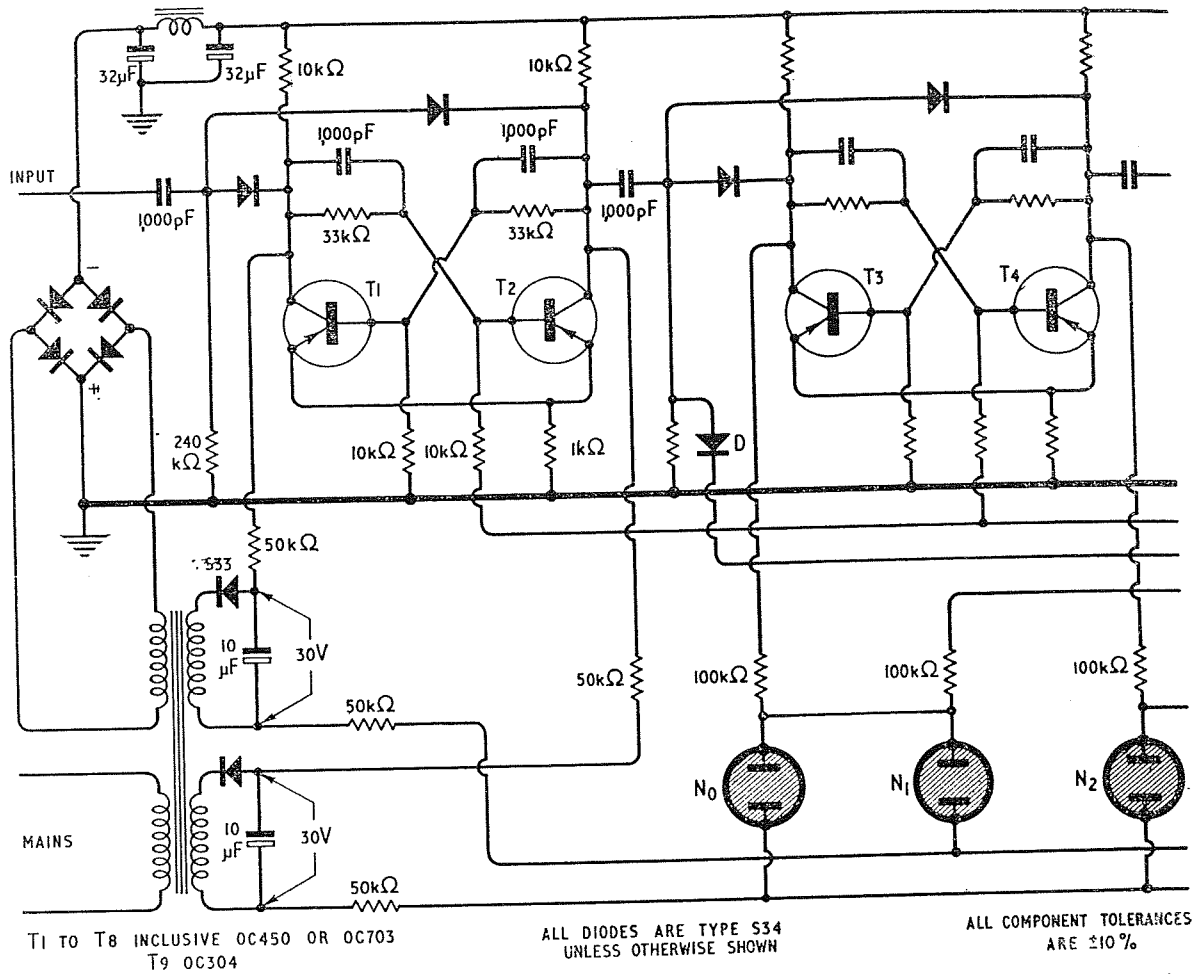

Fig. 8.14 Neon readout

In actual practice the meter should be returned to a potentiometer, VR_2 , as shown in Fig. 8.13(b), since the potential of the collector of a conducting transistor is not quite zero. The potentiometer VR_1 is provided so that the current can be adjusted to give a full scale deflection of the meter when all of the right hand transistors are conducting. The meter should have a full scale deflection of 0.5 mA and a resistance of 175 Ω . Ideally it should be scaled from 0 to 9. A stable power supply voltage is required, since the meter deflection depends on the voltage.

Meter readout can be used in the circuit of Fig. 8.11(a), but the resistor connected between the meter and the fourth binary must be one eighth of the value of that connected to the first binary.

DCTL Decade

Four binaries of the type shown in Fig. 8.3 may be combined to form a decade counter using the same feedback system as that of Fig. 8.12⁽¹²⁾. The circuit is exactly similar to that of Fig. 8.12, but the output pulses from each binary are taken from the left-hand transistors, since negative pulses are required. They are coupled into the succeeding stage by 500 pF capacitors. The maximum operating speed is about 1.5 Mc/s.

8.1.4 Neon Readout

Many transistor scalars operate with collector voltage swings of a few volts and cannot, therefore, operate small neon tubes, since the minimum volt-

SOLID STATE SCALING CIRCUITS

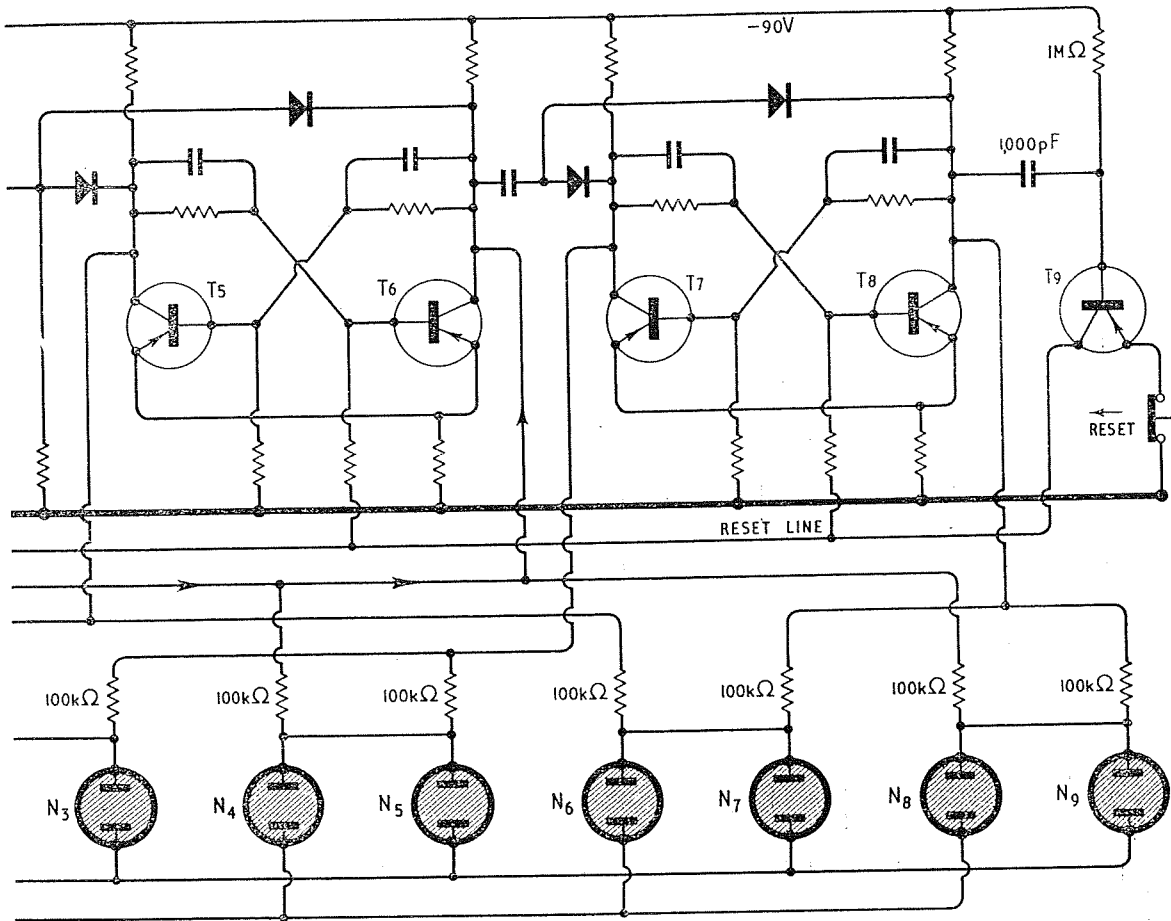

from a transistor decade

age required to ignite such tubes is of the order of 70 V. Such potentials can, however, be generated by decade circuits employing silicon transistors⁽¹⁷⁾. Four neon tubes may be used to provide binary readout or ten tubes may be used to provide decade readout.

A circuit which employs OC405 or OC703 transistors to provide decade readout using ten neons is shown in Fig. 8.14⁽¹⁸⁾. It has a maximum speed of about 35 kc/s. The base of the reset transistor, *T*₉, normally receives a bias current from the negative supply line via the 1 MΩ resistor. The transistor, therefore, conducts and effectively connects the reset line to earth. If the reset switch is opened, the bases of the right-hand transistors become negative and the circuit is reset to zero.

The circuit of Fig. 8.14 counts only the first five pulses in a binary manner. At the sixth input pulse the output from the first binary switches the second and third binaries. Positive pulses can pass from the first binary through the diode *D* to the third binary only when latter is not in its zero state. The next three pulses are counted in a binary manner, but at the tenth pulse the same feedback process occurs from the first to the third binary which leaves the circuit in the binary state 0010. When the fourth binary switches to zero, however, *T*₈ provides a positive pulse which stops the flow of current from the negative supply line to the base of *T*₉. This transistor becomes non-conducting and the second binary is reset to zero. The counting sequence is shown in Table 8.2

Table 8.2

No. of pulses	State of the binaries
0	0 0 0 0
1	0 0 0 1
2	0 0 1 0
3	0 0 1 1
4	0 1 0 0
5	0 1 0 1
6	1 0 1 0
7	1 0 1 1
8	1 1 0 0
9	1 1 0 1
10	(0 0 1 0)
	0 0 0 0

The six binary numbers omitted from the scale of sixteen are therefore 6, 7, 8, 9, 14 and 15.

This decade operates from a -90 V supply. The potential of the emitters of the binaries is about -10 V with respect to earth and the potential of the conducting collectors is little different from this. The potential of a cut off collector is about -70 V.

Neon tube decade readout may be obtained from this circuit as shown in Fig. 8.14. The anodes of the even numbered neons are all connected to a floating source of a constant potential of about 30 V. The other side of this source is connected to the right-hand transistor of the first binary. The anodes of the odd numbered neons are connected to a similar source of potential which is returned to the left-hand transistor of the first binary. In the zero state the potential of the anodes of the even numbered neons is therefore $(-10+30) = +20$ V with res-

pect to earth. The cathodes of the odd numbered neons are at $(-70+30) = -40$ V with respect to earth. Each time the first binary switches these voltages will be interchanged. The cathodes of the neons are connected via resistor networks to the collectors of transistors in the second, third and fourth binaries.

The voltages developed across each neon for each state of the decade is shown in Table 8.3. If the neons have an ignition voltage of between 70 and 80 V, it can be seen that the appropriate neon and no other will ignite to indicate the state of the count. The current passing through a neon (about 100 μ A) is determined by the two 100 k Ω resistors connected to the cathodes of each neon and the 50 k Ω resistors in the neon anode leads. The two windings for the 30 V supplies should be screened from the other transformer windings.

Another type of circuit employing decade neon readout is shown in Fig. 8.15⁽¹⁹⁾. The transistors used in the binaries operate from low voltage supplies and a transistor amplifier is, therefore, required to operate each neon. Four of the binaries and ten of the readout circuits are connected as shown in the block diagram of Fig. 8.15(c). The first seven pulses are counted in a binary manner, but the eighth pulse switches the fourth binary and a signal is fed back to switch both the second and third binaries. The operational sequence is the same as that used in the circuit of Fig. 8.12. The neon tubes used should ignite when the applied voltage is between 50 and 75 V. The maximum counting frequency is about 200 kc/s.

Table 8.3

State of Decade	N_0	N_1	N_2	N_3	N_4	N_5	N_6	N_7	N_8	N_9
0	90	30	60	0	60	0	60	0	60	0
1	30	90	0	60	0	60	0	60	0	60
2	60	0	90	30	60	0	60	0	30	-30
3	0	60	30	90	0	60	0	60	-30	30
4	60	0	60	0	90	30	30	-30	60	0
5	0	60	0	60	30	90	-30	30	0	60
6	60	0	60	0	30	-30	90	30	60	0
7	0	60	0	60	-30	30	30	90	0	60
8	30	-30	30	-30	60	0	60	0	90	30
9	-30	30	-30	30	0	60	0	60	30	90

8.1.5 Numerical Indicator Tube Readout

Many types of numerical indicator tube can be driven from a low voltage transistor scaler if a diode matrix is employed to convert the binary readout to decimal readout. Ten NPN transistors are also required to amplify the currents from the matrix so that they are large enough to operate the indicator tube. A typical circuit⁽²⁰⁾ for operating the GR10H tube is shown in Fig. 8.16. The scaler should count in the binary manner up to nine and be reset

at the tenth pulse. The circuit is designed to operate with a collector voltage swing of the binary transistors between -1.5 V and the earth potential. A few indicator tubes (such as the GR10G) are not very suitable for use in this type of circuit, since there is a large amount of ionisation coupling between adjacent cathodes and a large bias is required on the unused cathodes.

The use of the Z550M which has been specially developed for providing readout from transistor scalers will be discussed in Chapter 10.

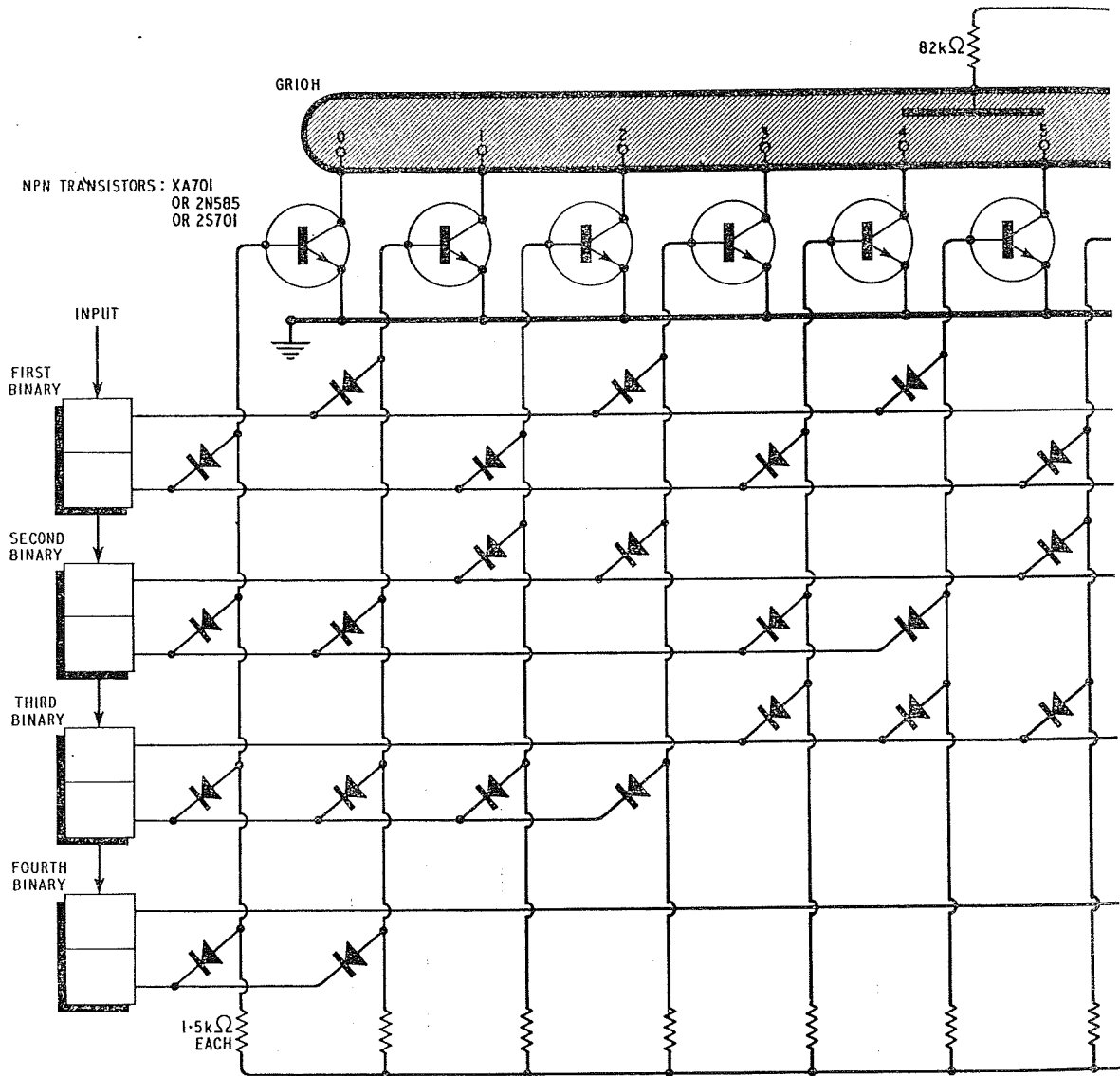
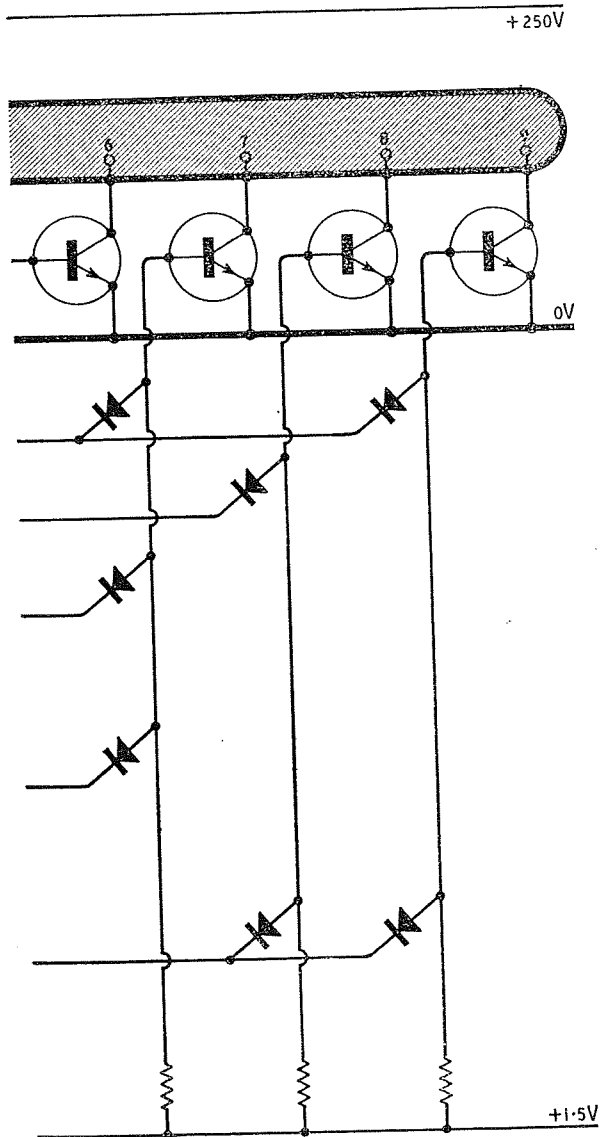

Fig. 8.16 The operation of a numerical indicator

8.1.6 10 Mc/s Decade

Transistors with cut off frequencies of the order of 300 Mc/s are suitable for use in saturated decade circuits at frequencies up to about 10 Mc/s. A circuit using germanium diffused mesa PNP 2G103 transistors is shown in Fig. 8.17⁽²¹⁾. This circuit counts to nine in the binary code and is then reset. The emitter follower T_3 is included to ensure that the capacitance loading of the first binary is kept



tube from a transistor decade

reasonably small. The output of T_3 either switches the second or the fourth binary according to the state of the latter. When T_9 conducts, the presence of D_5 ensures that the junction of D_4 , D_5 and D_6 never becomes negative with respect to the output potential of the decade (-0.2 V). Positive pulses applied to the second binary are able to pass through D_4 or D_6 to switch the stage. When T_9 is cut off, however, D_5 is reverse biased and its reverse leakage causes the potential at the junction of the three diodes to fall to -6 V, thus reverse biasing D_4 and D_6 . No pulses can now pass from the first to the second binary.

D_{10} functions in a similar way to D_5 . When T_8 is conducting, pulses at the junction of D_{10} and D_{11} will switch the fourth binary, but when T_8 is cut off, D_{10} and D_{11} are reverse biased and pulses from T_3 will not be able to pass through D_{11} to switch the fourth binary. Nevertheless pulses from T_7 will be able to switch the fourth binary, since they do not have to pass through D_{11} . The tenth pulse is thus gated from the first to the fourth binary.

The silicon gating diodes have forward and reverse recovery times of less than 4×10^{-9} sec. The maximum speed of the decade is, therefore, virtually the same as that of the first binary. Each conducting transistor passes a current of about 25 mA, but this cannot be appreciably reduced, however, without an increase in the resolving time taking place.

The meter readout is similar to that described for Fig. 8.13, but the readout resistor connected to the fourth binary must be one eighth of the corresponding resistor connected to the first binary, since a different feedback system is being employed. Each count produces 0.4 V into an open circuit or 70 μ A into a short circuit. A meter with a full scale deflection of 630 μ A or 3.6 V and scaled 0 to 9 is therefore required. The power consumed by the decade is less than 1 W.

Reversible transistor decade counters can be constructed if either output from the collectors of each binary can be used to trigger the next stage. The selection of the appropriate output can be made by transistors and this controls the direction of counting⁽²²⁾.

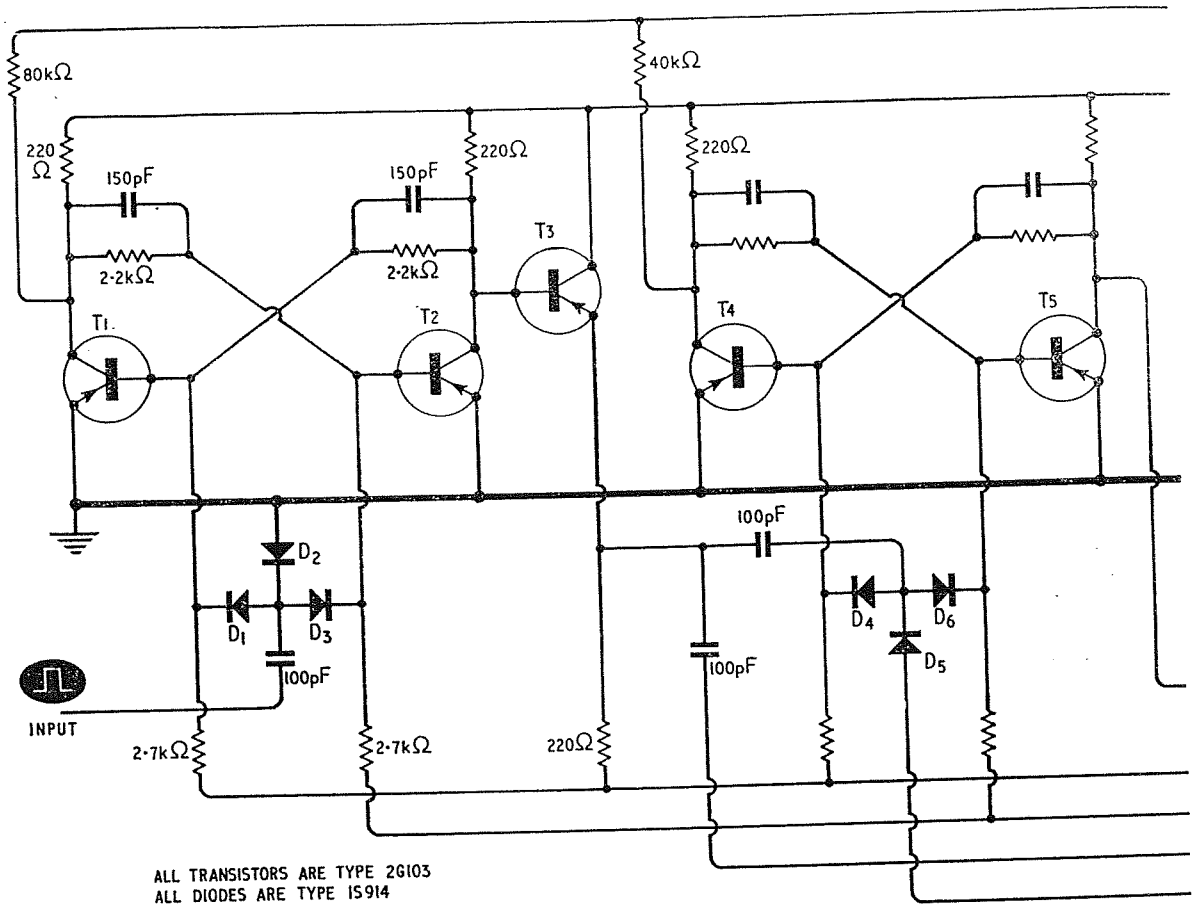

ALL TRANSISTORS ARE TYPE 2G103
 ALL DIODES ARE TYPE 1S914

Fig. 8.17 A 10

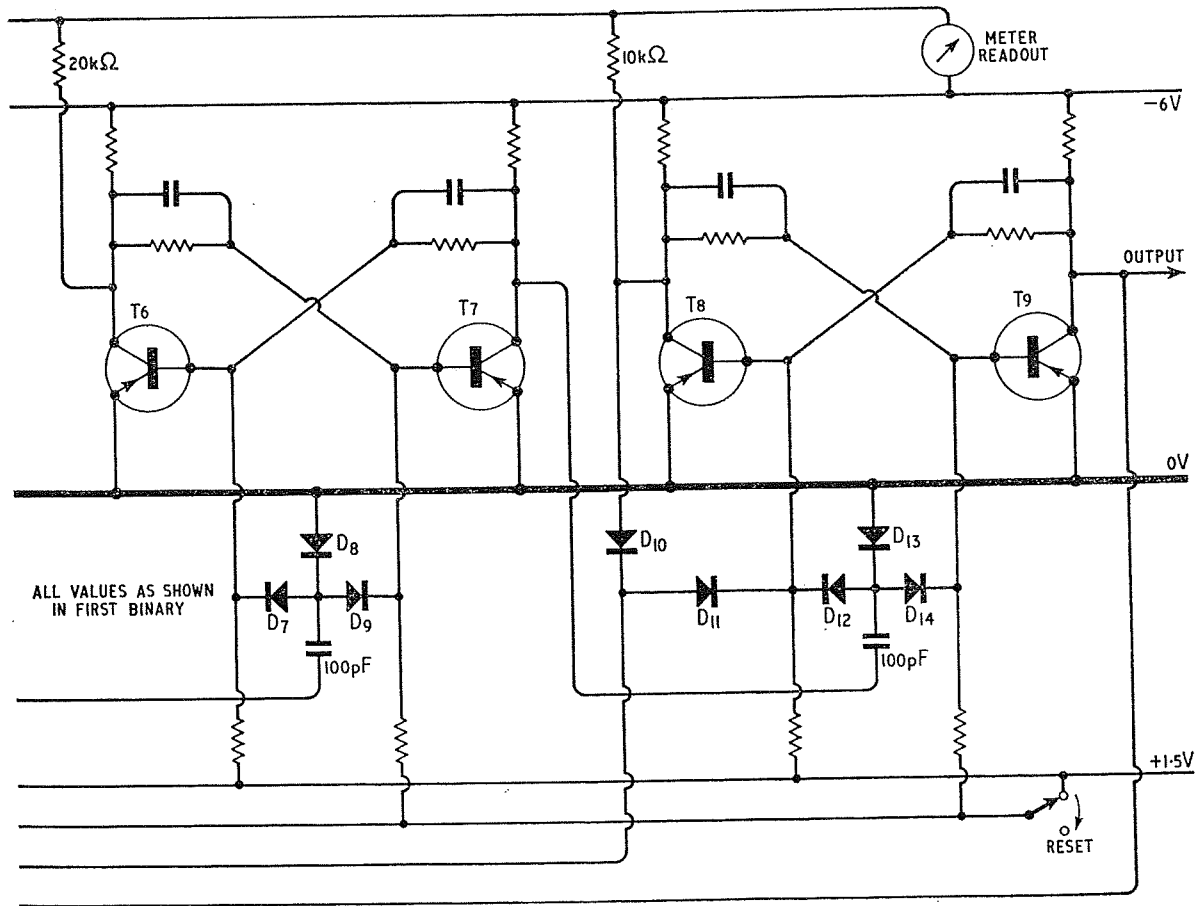

Mc/s scaler.

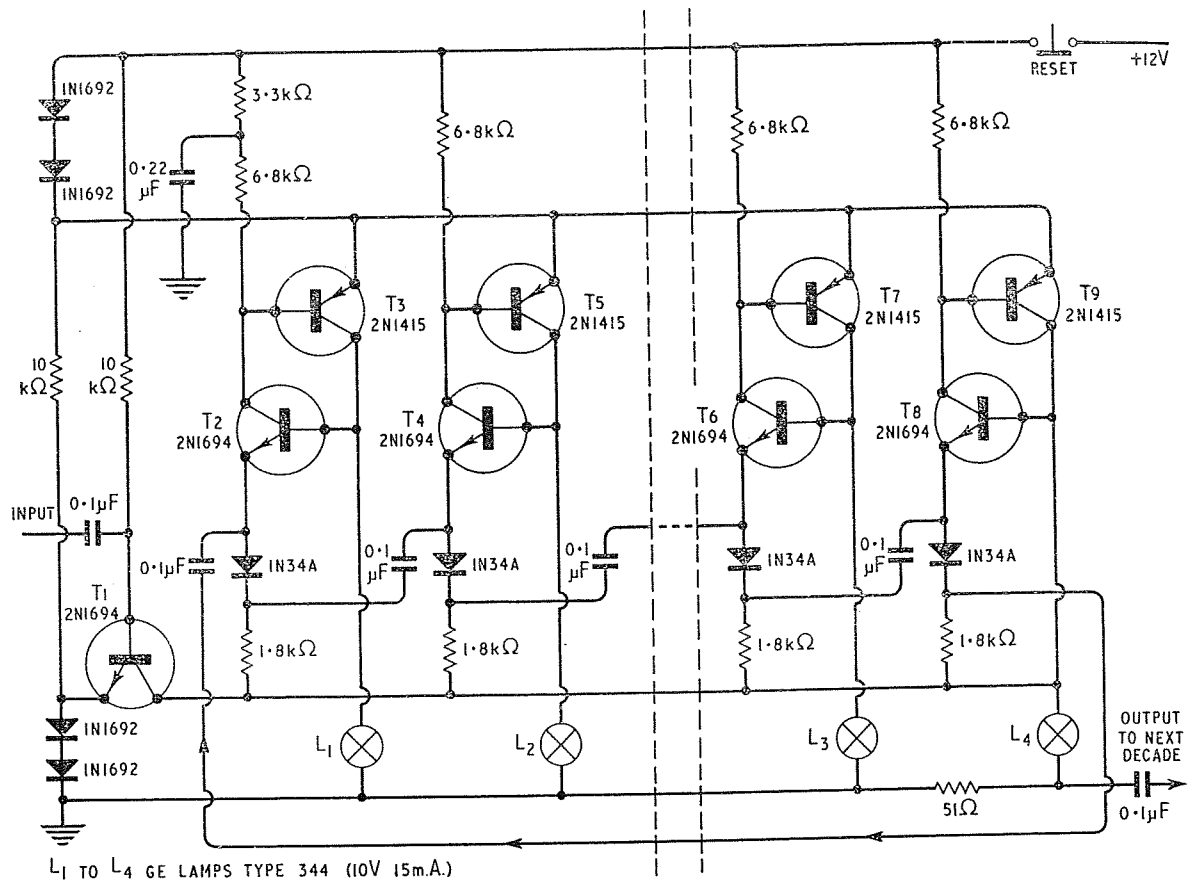

Fig. 8.18 A transistor ring counter

8.1.7 Ring Counter

A ring counter employing complementary symmetry bistable circuits is shown in Fig. 8.18⁽²³⁾. Any number of stages may be included in the ring, only a very small current being drawn by the non-conducting stages. Readout is effected by means of filament lamps. The transistor T_1 is a triggering transistor which amplifies the incoming pulses. When the reset button is pressed, the power supply is interrupted and the charge of the $0.22 \mu\text{F}$ capacitor in the circuit of the first stage ensures that this stage will conduct when the reset button is released.

8.1.8 Counters Employing a Diode Matrix

The Burroughs Corporation manufacture decimal counter modules ('BIPCO') type BIP-8001 which can count at up to 110 kc/s and provide visual

readout by means of a 'Nixie' numerical indicator tube. The circuit of this type of counter is shown in Fig. 8.19⁽²⁴⁾. The counter consists of a matrix of 90 diodes operating in conjunction with ten single transistor amplifiers and a bistable circuit containing two NPN transistors. The amplifiers are marked A_0 to A_9 in the circuit of Fig. 8.19. The inset shows the circuit of the A_0 amplifier which provides the output pulse to the next decade. The circuits of the other nine amplifiers are similar, but the dotted components are omitted, since no output pulse is needed.

One of the ten amplifiers A_0 to A_9 is always conducting at any time. If A_1 is conducting, the corresponding digit in the indicator tube will be glowing and the wire C from the cathode of the Nixie tube will be at a low potential. This wire is connected to amplifiers A_3 to A_0 inclusive via the diodes. The bases of the NPN transistors are, therefore, pre-

vented from becoming more positive than *C* and are cut off. When *A1* is conducting, the binary will be in the state in which the wire marked *A* is at about earth potential and *A2* will be cut off.

If an input pulse is used to switch the binary, the potential of the wire *B* will fall to about earth potential whilst that of wire *A* will rise to about 12 V. *A1* is therefore cut off and *A2* conducts. This results in the Nixie tube indicating the new count and the low potential of the wire *D* ensures that the amplifiers *A1* and *A4* to *A0* are cut off. Each input pulse changes the state of the binary and causes the next amplifier to conduct. When the amplifier *A0* conducts, an output pulse is produced which can be used to operate the next decade. This type of counter is effectively a ring of ten transistor amplifiers which are controlled by the diodes and the binary circuit. One of its main advantages is that the Nixie tube is driven directly from the ring without buffer amplifiers.

The negative going input pulses should have an amplitude of between 9 and 14 V and a duration of at least 2 μsec ; their rise time should not exceed 0.5 μsec . The negative going resetting pulses should have an amplitude of at least 55 V and a minimum duration of 9 μsec . Electrical readout (up to 0.5 mA) may be obtained from the cathodes of the Nixie tube. When a cathode conducts, its potential falls from +55 V to +1 V nominal.

A similar module, the BIP-8002, can be used for reversible counting at frequencies of up to 20 kc/s.

8.1.9 Fast Scalers

Various circuit techniques have recently been developed to utilise suitable transistors for counting at frequencies up to at least 200 Mc/s⁽²⁵⁾. Very high speed non-saturating binaries may be used or alternatively decade counters may be designed with gates connected in such a way that each binary reverses its state only once during the time several input pulses are applied to the circuit.

A 200 Mc/s scale of eight which may be followed by a 30 Mc/s decade scaler has been designed at Harwell⁽²⁶⁾. This scaler has been developed from the non-saturating circuit of Chaplin and Owens⁽²⁷⁾ which was limited in frequency by the performance

of the transistors which were available at that time. The binary circuits used employ a differentiating transformer instead of the usual capacitive coupling. A binary stage of this type is shown in Fig. 8.20⁽²⁶⁾. D_2 is a 4.7 V zener diode.

When *T1* is conducting about 6.7 mA passes to the emitter which assumes a potential of +0.2 V. The current flowing through D_3 produces a potential of 0.5 V across it. *T2* is thus cut off.

A short negative going input pulse of at least 1 V amplitude will reduce the emitter potential of *T1* so that it cuts off. A current now flows through D_4 , D_2 and R_3 so that the base of *T2* is at a potential of -0.5 V. At the end of the input pulse *T2* will conduct before *T1*, since its base is more negative than that of *T1*. The flow of current through R_1 (7 mA) results in the common emitter potential becoming -0.3 V which prevents *T1* from conducting.

A second input pulse reduces the common emitter potential so that *T2* is cut off. A voltage is induced in the transformer when the current passing through it from *T2* ceases. This voltage is arranged to have a duration somewhat longer than that of the input pulse and is applied to the base of *T1* as a negative going pulse. *T1* therefore commences to conduct at the end of the input pulse and the circuit returns to its first stable state. R_4 is used to critically damp the transformer voltage.

When *T2* commences to conduct, the positive overshoot at its collector may be inverted by the transformer and used for triggering the succeeding stages. The step down ratio of the transformer increases the output current available for the operation of the succeeding stage. A transistor coupling amplifier is required when the resolving time of the circuit is reduced below 0.1 μsec , since the output pulse amplitude decreases with resolving time. No step down winding is then required and a smaller primary inductance may be used which helps to reduce the resolving time.

The transformers consist of two ferrite tubes with the wires passed through them. These components are small and the inductance may be varied by altering the type of ferrite. If a resolving time of 5×10^{-9} sec is required, 2N700 transistors may be used with a transformer consisting of two rods of Mullard FX1 361 ferrite each $\frac{3}{8}$ in. long. The

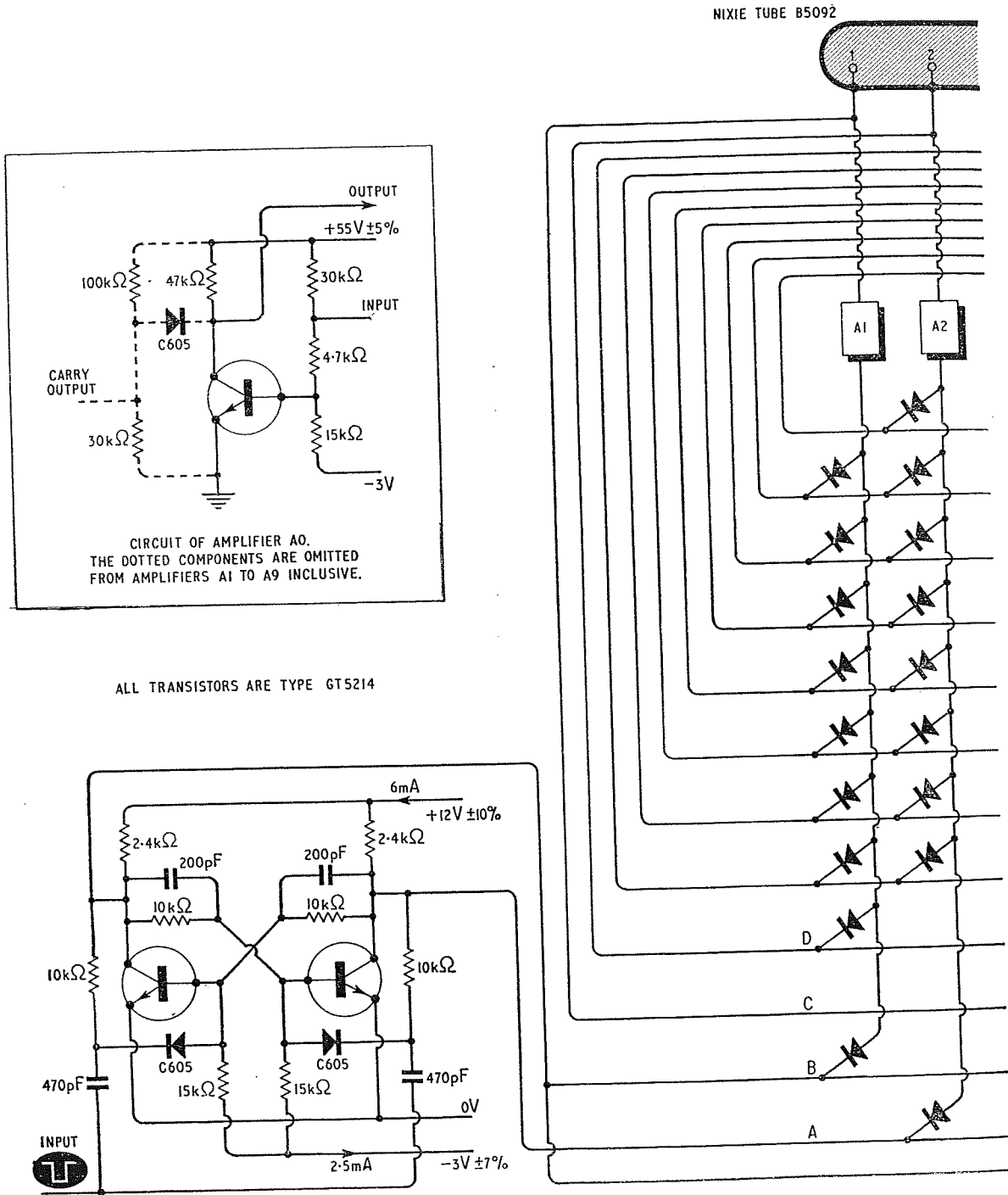
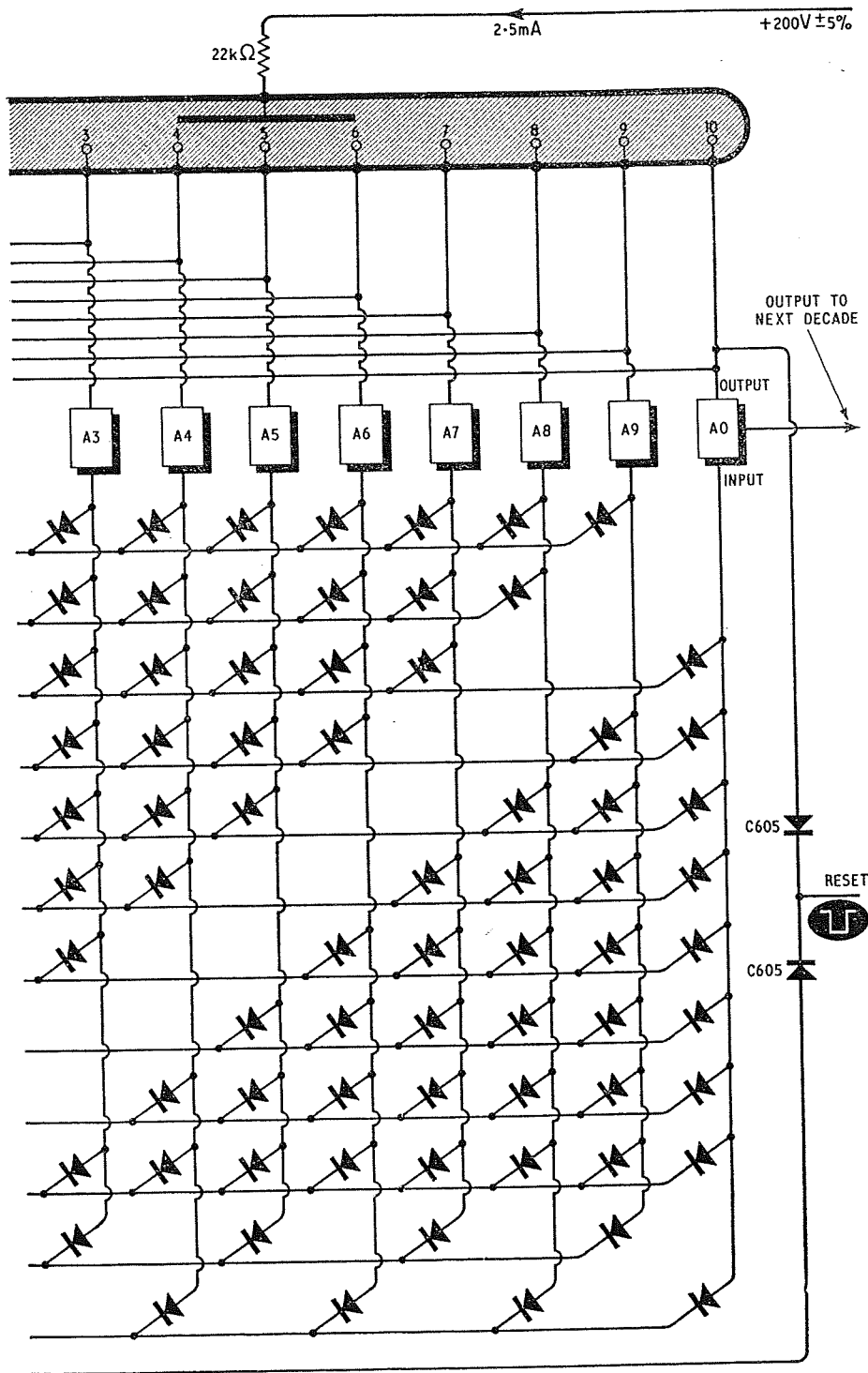

Fig. 8.19 The Burroughs



BIP-8001 decade counter

ELECTRONIC COUNTING CIRCUITS

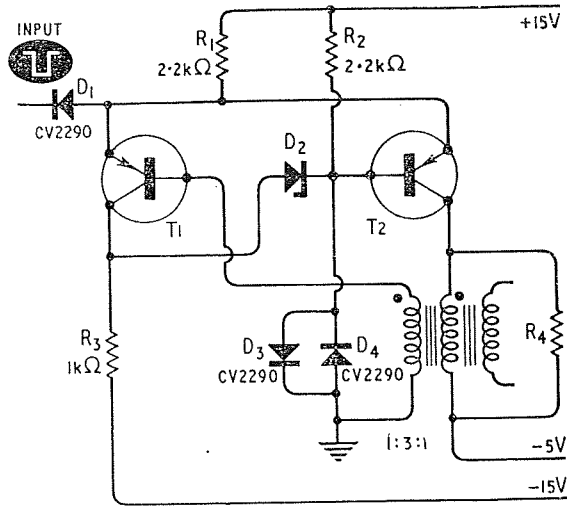

Fig. 8.20 A basic high speed binary circuit

transformer design should be varied according to the type of transistors used.

A 200 Mc/s scale of eight is shown in Fig. 8.21⁽²⁶⁾. The first two binaries use 2N700 mesa transistors whilst the third binary can employ a 2N501 microalloy diffused transistor. T_1 , T_5 and T_8 are the coupling transistors. Circuits for a 30 Mc/s and a 3 Mc/s decade scaler constructed with the same type of binary circuit as Fig. 8.20 have been published⁽²⁶⁾.

8.1.10 Special Coding Systems

The maximum operating frequency of conventional types of transistor counters is limited to a value somewhat less than the maximum frequency of the first binary. However various systems have been devised in which no binary counts at a speed as

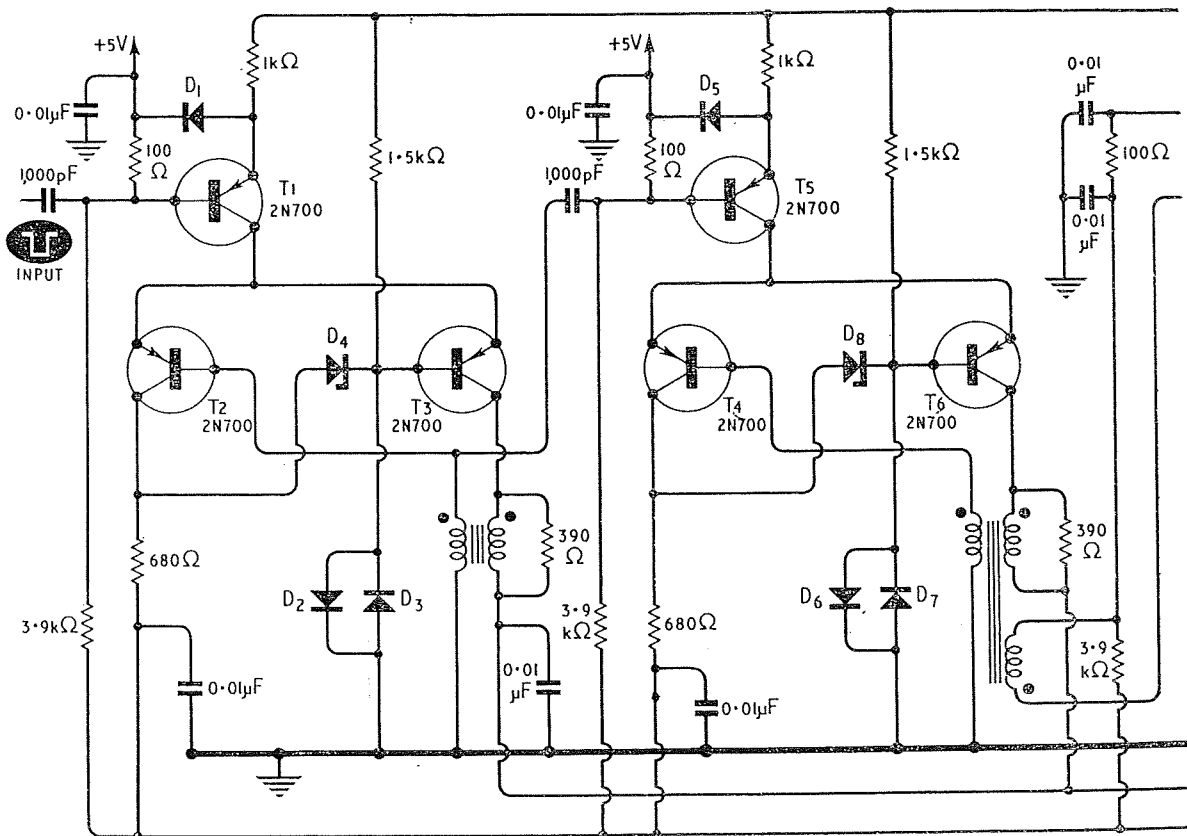

Fig. 8.21 A 200 Mc/s scale of eight. $D_1, D_2, D_3, D_5, D_6, D_7, D_9, D_{10}$ and D_{11} are diodes CV2229; D_4, D_8 and D_{12} transistors; T_7-T_9

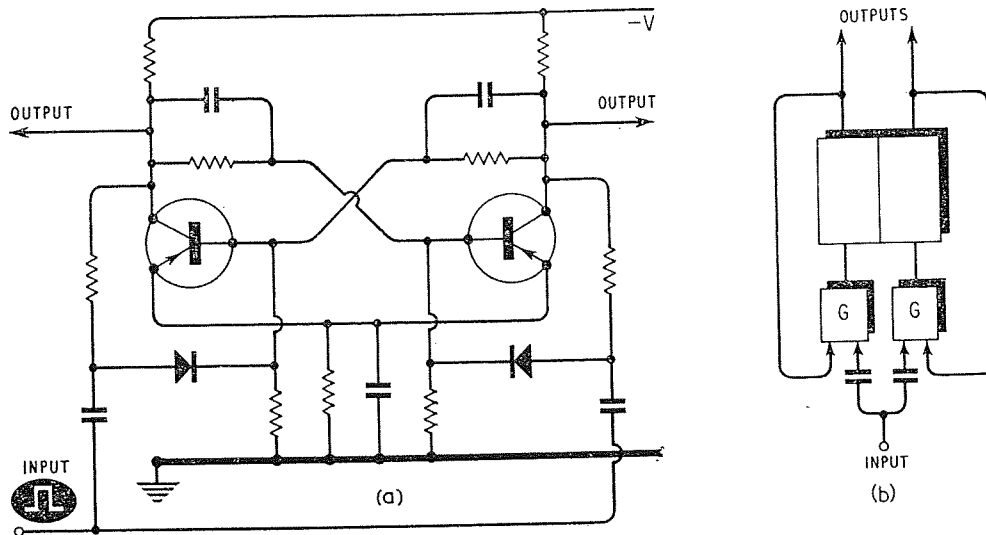
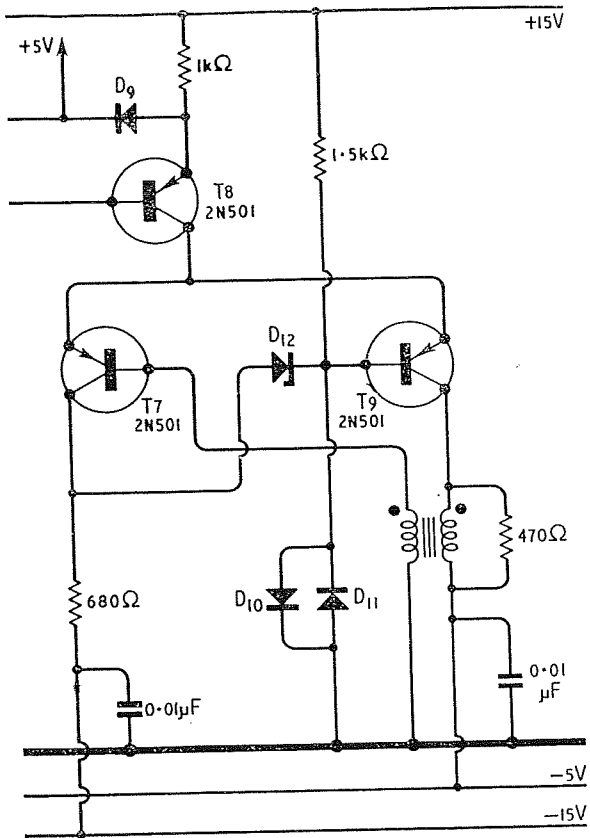

Fig. 8.22 A gated binary and its symbol



are 4.7 V Zener diodes (SX47); T1-T6 are 2N700 are 2N501 transistors

great as that of the input frequency. These types of counter use the state of the binaries to control gates which determine which binary will be switched by the next input pulse. Saturated binaries can be used in these type of circuits at input frequencies of up to about 200 Mc/s.

In order to show the functioning of such circuits, it is convenient to use the symbol shown in Fig. 8.22(b) to represent the binary of Fig. 8.22(a) with its diode gating circuits. Each gate feeds a transistor base and the collector potential of the same transistor is used to open or close this gate. If a transistor is in the cut off state, its collector applies a negative potential to the gate feeding its base and no pulses can pass to it. Positive going input pulses are gated to the conducting transistor which is thus cut off. Two outputs are available, but in normal cascaded binary circuits only one of them is used. In the circuits to be discussed the collector potentials of each binary are used to gate the input circuits of other binaries. The resolving time is determined more by the speed of the gating circuits than by the speed of the binaries.

An example of a counting circuit using a special coding system is shown in Fig. 8.23⁽²⁸⁾. The positive going input pulses are fed to all gates, but a pulse will not be able to pass through a gate unless the collector of the transistor in the other binary to

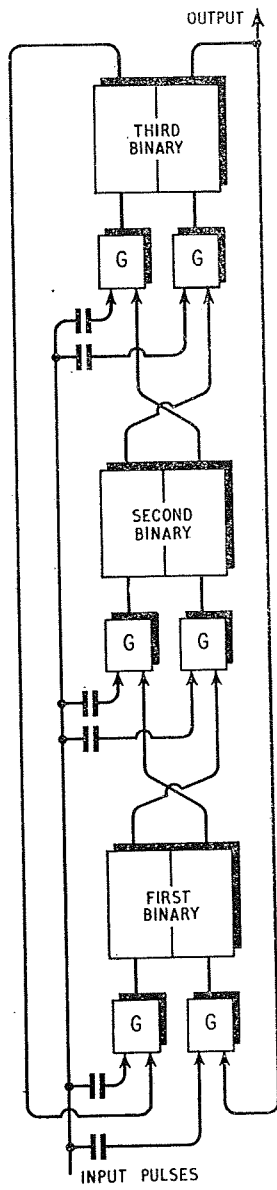

Fig. 8.23 A scale of six circuit

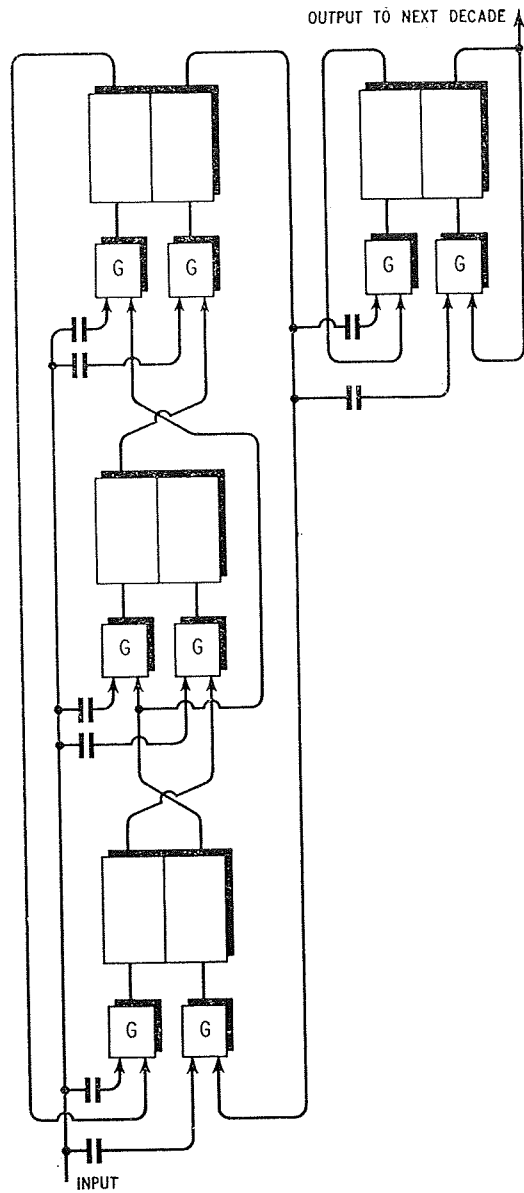

Fig. 8.24 A decade scaler

which the gate is connected is conducting. If a pulse passes through a gate, it will not switch the stage unless it passes to the side of the binary which is conducting.

In order to illustrate the cycle of operation, all of the binaries will be assumed to have been reset to the zero state in which the right-hand transistor is conducting. An input pulse applied to the circuit will be able to pass to the left-hand transistors of the second and third binaries, since their gates are connected to the conducting transistors in the previous stages, but no effect will be produced, as an input pulse will not affect a cut off transistor which is already in the state to which the input pulse would advance it. The input pulse can also reach the right-hand conducting transistor of the first binary because the gate feeding this transistor is connected to the conducting side of the third binary. The first binary is therefore switched. The gates feeding the left-hand side of the first binary and the right-hand sides of the second and third binaries are closed in the zero state.

When a second input pulse is applied to the circuit, it cannot affect the first binary, since it can reach only the non-conducting side of this stage via the right-hand gate. The switching of the first binary has, however, opened the gate which feeds the right-hand side of the second binary; the latter is therefore switched. The gate to the right-hand side of the third binary is now open and this stage will be switched by the third input pulse. The switching of the third binary opens the left-hand gate to the first binary so that the fourth input pulse switches the first stage back to zero. The fifth and sixth input pulses switch the second and third binary stages respectively back to zero. Thus after six pulses the whole counter has been reset. The coding for the operation of this type of counter is shown in Table 8.4.

It can be seen that each binary is switched only once for each three input pulses which are applied to the circuit. The system may be compared with a ring circuit, but the change of state travels around the ring twice instead of once per cycle as in standard ring counters.

The capacity of this type of counter is only $2n$ counts where n is the number of binary stages

Table 8.4

No. of Pulses	State of the Binaries		
	3rd	2nd	1st
0	0	0	0
1	0	0	1
2	0	1	1
3	1	1	1
4	1	1	0
5	1	0	0
6	0	0	0

employed, but a normal binary counter has a capacity of 2^n counts. One method by which the same count capacity as a normal cascaded binary counter may be achieved and in which the speed of the first binary is halved involves the use of the Gray code⁽²⁹⁾ which is shown in Table 8.5.

Table 8.5

No. of Pulses	State of the Binaries		
	3rd	2nd	1st
0	0	0	0
1	0	0	1
2	0	1	1
3	0	1	0
4	1	1	0
5	1	1	1
6	1	0	1
7	1	0	0
8	0	0	0

The circuit of Fig. 8.24 is a decade scaler based on the circuit of Fig. 8.23⁽²⁸⁾. The group of three binaries has been made into a scale of five by connecting the left-hand gates of the second and third binaries to the collector of the right-hand transistor of the first binary. At the fifth pulse the second and third binaries switch simultaneously. A binary circuit follows the scale of five so that the overall circuit forms a scale of ten.

Many high speed scalars are constructed on the principle of Fig. 8.23, but two additional binaries are used in the ring to make a scale of ten⁽³⁰⁾. Such circuits may be called 'five binary decimal counters'. Each binary counts at only one fifth of the pulse

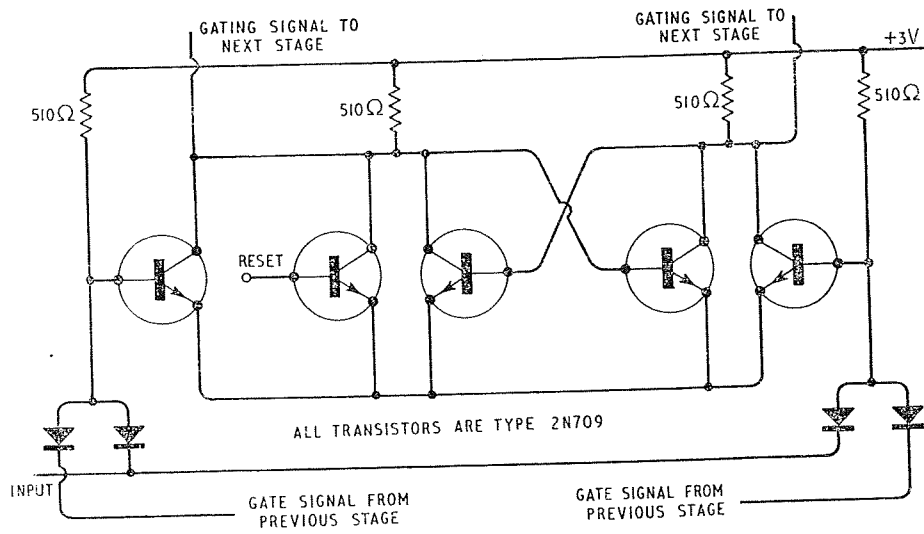

Fig. 8.25 An LLDL binary stage

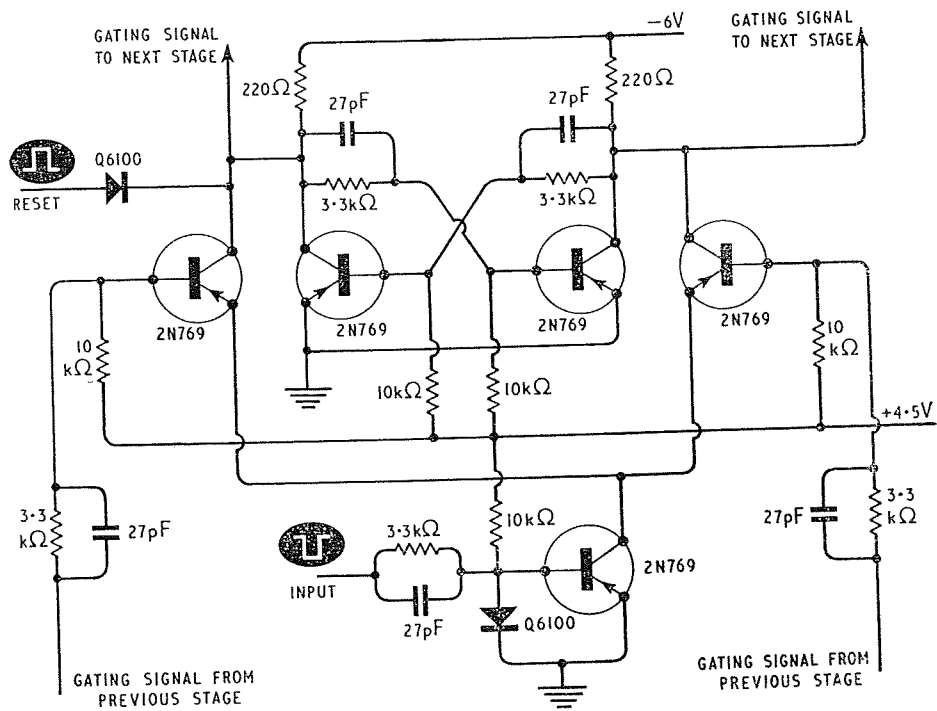

Fig. 8.26 A saturated binary stage for 100 Mc/s five binary decimal counting

input frequency, but one more binary is required in each decade than is employed in the circuit of Fig. 8.24. Five of the binary circuits shown in Fig. 8.25 may be used to construct a 100 Mc/s five binary decimal counter⁽³¹⁾. The connections are exactly similar to those of Fig. 8.23, but five stages are used in the ring. The circuit employs NPN 2N709 transistors which have a cut off frequency of 1,000 Mc/s in low level diode logic circuits.

A number of circuits have been published recently in which all transistor logic circuits are used in five binary decimal counters⁽³¹⁻³³⁾. A saturated binary circuit designed for 2N769 transistors is shown in Fig. 8.26; it may be used in 100 Mc/s five binary decimal counters⁽³²⁾. Both the gating and counting are performed by transistors.

The length of the input pulse which is used to operate a five binary decimal counter must be carefully controlled. It must be greater than the rise time of the gating circuit, but if it is too long, it may cause more than one binary to switch. The loading imposed by the circuit on the source of input pulses can be considerable, since both sides of all of the binaries are connected to the input.

Five binary decimal counters are normally constructed in a circle with the common input connection at the centre in order to minimise lead lengths. It is possible to obtain miniature encapsulated circuits containing several transistors and the use of such circuits enables higher operating speeds to be obtained, since the stray inductance and capacitance can be made very small. The use of five binary decimal counters enables high speed saturating scalars to be designed which have a much smaller power dissipation than non-saturating scalars. This type of circuitry is a great aid to miniaturisation.

8.2 SCALERS USING FOUR LAYER SWITCHING DEVICES

A number of semiconductor devices which have a four layer PNP structure are being marketed under various names including 'Trigistor', 'Transwitch', 'Four Layer Diode', 'Shockley Diode', 'Trinistor', 'Silicon Controlled Rectifier', 'Dynaquad', 'Silicon Controlled Switch', etc. In all types connections can be made to the two layers at each

end of the PNP structure, but some types are three terminal devices in which a current can be passed to one of the inner layers. The silicon controlled switch is a four terminal device with connections to all of the four semiconductor layers. A connection made to the P type inner layer is known as a P gate and a connection to the N type inner layer as an N gate.

PNP devices are very suitable for use in ring counters, since they possess somewhat similar properties to cold cathode tubes, but have the advantages that they can operate at much higher speeds and are much more efficient.

In a four layer diode, connections are made only to the two layers at each end of the device. A single four layer diode has two characteristic stable states. In one state the impedance is about 100 M Ω whilst in the other state it is only a few ohms. When a small voltage is applied across it, the diode is in its high resistance state but (like a neon diode) it can be switched into its conducting state by the application of a voltage above a certain minimum value; this minimum value is known as the 'breakover' voltage (V_{bo}). In some devices the switching occurs in 0.1 μ sec.

The diode can be returned to its high resistance state by reducing the current passing through it below a certain value which is known as the holding current. The time taken is not usually much less than 1 μ sec, since stored charges must be removed before the switching operation is completed.

If the PNP device is a three or four terminal one, it can be operated in a similar way to a trigger tube. The voltage applied across the whole device is normally somewhat less than the breakover voltage, but a suitable current pulse applied to one of the inner layers will cause switching to the low resistance state to take place. The device will remain in the low resistance state until either the main anode to cathode voltage is removed or until a pulse of opposite polarity is applied to one of the inner layers. A negative pulse applied to a P gate or a positive pulse applied to an N gate can be used to stop conduction. Trigger tubes do not possess a comparable property.

The form of the characteristic curve of a PNP device is shown in Fig. 8.27. The high impedance

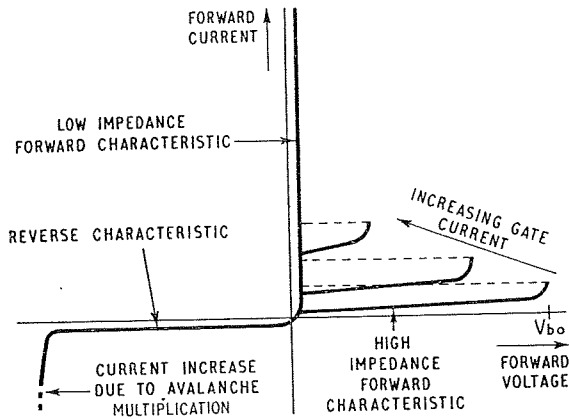

Fig. 8.27 The characteristics of a PNP device

forward characteristic is almost a mirror image of the reverse characteristic, but soon after the curved part of the forward characteristic is reached, the device will switch to the low impedance state by following the dotted line. It can be seen that as the gate current increases, the breakover voltage de-

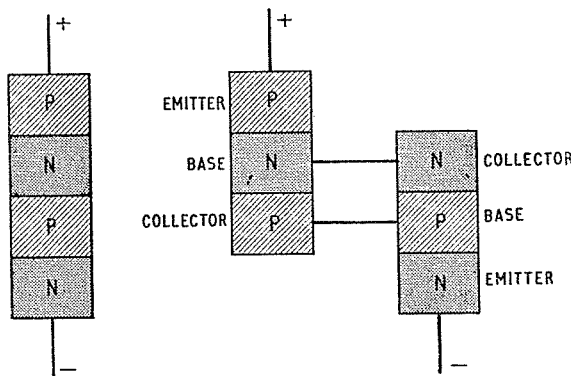

Fig. 8.28 A PNP device is equivalent to a PNP and an NPN transistor connected as shown

creases. PNP devices can be produced with a low reverse impedance.

Fig. 8.28 shows that a PNP device can be regarded as a PNP and an NPN transistor connected as in the bistable circuit of Fig. 8.8. The collector of the one transistor is the same layer as the base of the other. Forward biasing occurs when the applied voltage has the polarity shown. The two outermost junctions are forward biased, but the centre junction is reverse biased. The whole device

therefore has a high impedance until the potential across it is increased to the point at which avalanche multiplication occurs at the centre junction. This effect may be compared with the avalanche effect in gas filled tubes. If a positive potential is applied to the inner P layer or a negative potential to the inner N layer (each of which is the base of one of the transistors), the current will be amplified by normal transistor action and switching to the low impedance state will occur. The gate current effectively lowers the breakover voltage.

8.2.1 Circuits Using PNP Diodes

A simple ring counter using four layer or Shockley diodes is shown in Fig. 8.29⁽³⁴⁾. The four layer diodes are marked $4D_1, 4D_2$, etc. The diode $4D_1$ is a triggering diode which amplifies the input pulse; it is not part of the ring. Any number of additional stages may be included between the dotted lines.

When the supply voltage is first applied to the circuit, one of the four layer diodes will switch to its low resistance state. It will then pass a current which produces a large enough voltage drop across R_2 and R_3 to prevent any other diode in the ring from conducting. The value of R_1 is large enough to prevent $4D_1$ being switched to the conducting state, since this resistor will not pass the holding current with the supply voltage specified.

A negative pulse of 16 to 36 V in amplitude applied at the junction of $4D_1$ and D_1 will cause $4D_1$ to be momentarily switched to the conducting state and its anode voltage to fall virtually to earth potential. This negative voltage pulse is coupled through C_1 to the H.T. supply line in the ring counter, the potential of which falls also. The stage which was conducting is thus switched to its high resistance state. The coupling capacitor in the anode circuit of the conducting stage has charged during the conduction period and, as the potential of the H.T. supply line rises again, the potential across this capacitor is added to the supply potential so that the succeeding stage is switched. Each input pulse thus causes the state of conduction to advance one place in the ring.

The diode $4D_1$ may be a 4D40-10 with a nominal switching potential of 40 V, whilst the other four

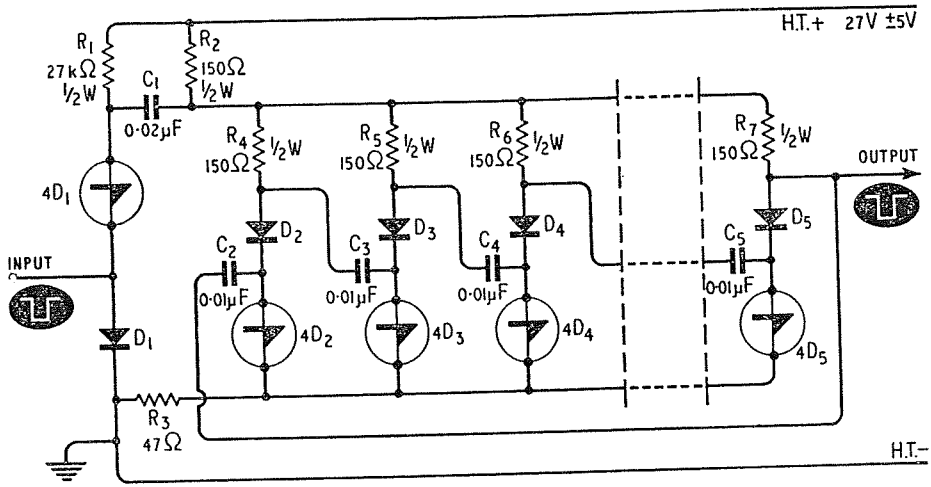

Fig. 8.29 A 2 kc/s ring counter using four layer diodes

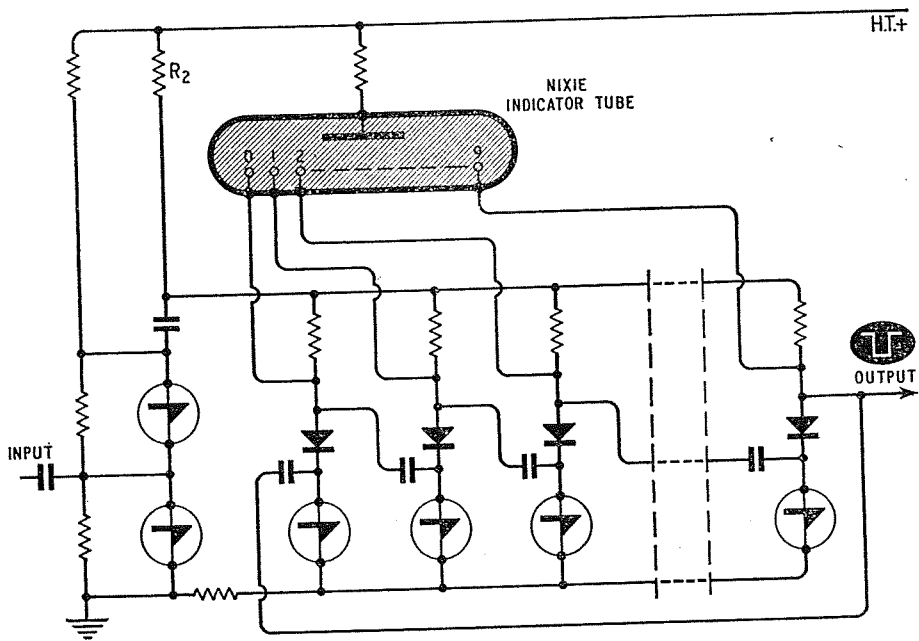

Fig. 8.30 Nixie tube readout from a Shockley diode ring counter

layer diodes may be type 4D20-10 which have a switching potential of 20 V. Both types have holding currents of 10 ± 5 mA. The silicon diodes D_1 to D_5 may be type 1N461 or similar. If a positive going output pulse is required, it may be obtained by placing a resistor of low value in the cathode circuit of the final stage. Somewhat higher counting speeds may be obtained if a transistor trigger stage is used instead of D_1 , $4D_1$ and R_1 .

The circuit may be modified so that it can drive a 'Nixie' numerical indicator tube as shown in Fig. 8.30⁽³⁵⁾. This tube requires an ignition potential of at least 250 V and R_2 must therefore be large so that only one stage of the ring conducts at any time. The diode D_1 of Fig. 8.29 must be replaced with a four layer diode and resistors should be placed in parallel with the four layer triggering diodes to divide the voltage equally between them.

A similar circuit has been designed for reversible counting in which two four layer diodes are used in each stage⁽³⁶⁾. Circuits for use at 20 kc/s with neon tube readout have also been published⁽³⁷⁾.

8.2.2 Three Terminal Devices

The Trigistor is a silicon PNP device with a connection to the inner P layer (P gate). Trigestors type 3C30 may be used in ring counters of the type shown in Fig. 8.31 for operation at frequencies up to at least 10 kc/s⁽³⁸⁾. The input is maintained at a quiescent potential of +10 V which falls to +5 V

during the pulse. If T_2 is conducting, the upper (anode) side of D_2 will be at +10 V and the negative going input pulses will be able to pass through D_2 to T_2 . If T_2 is initially conducting, it will be switched to its non-conducting state by an input pulse. When T_2 is conducting, the anode of the diode D_3 will be at about earth potential. D_3 will therefore be reverse biased, since the potential of the input line is always at least 5 V positive with respect to earth (although the pulse itself is negative going). Therefore each Trigistor except the one following the conducting stage will receive a 'turn off' pulse each time an input pulse is applied. When a stage is switched off, the resulting positive going pulse is coupled by a capacitor to the gate electrode of the next stage which is thus switched to conduction.

A circuit which employs germanium ATZ10 transistors with an OC41 driver stage is shown in Fig. 8.32⁽³⁹⁾. The load resistors are arranged so that only one stage can conduct at any time. When the OC41 driving transistor is switched to conduction, its emitter current reduces the current available to the stages in the ring which are thus switched off. When the conducting stage is switched off, it passes a positive going pulse through the coupling capacitor to the base of the succeeding stage; the latter is turned on at the end of the input pulse. The maximum frequency is about 30 kc/s.

Ring circuits using silicon P gate devices for frequencies up to 100 kc/s⁽⁴⁰⁾ have been designed,

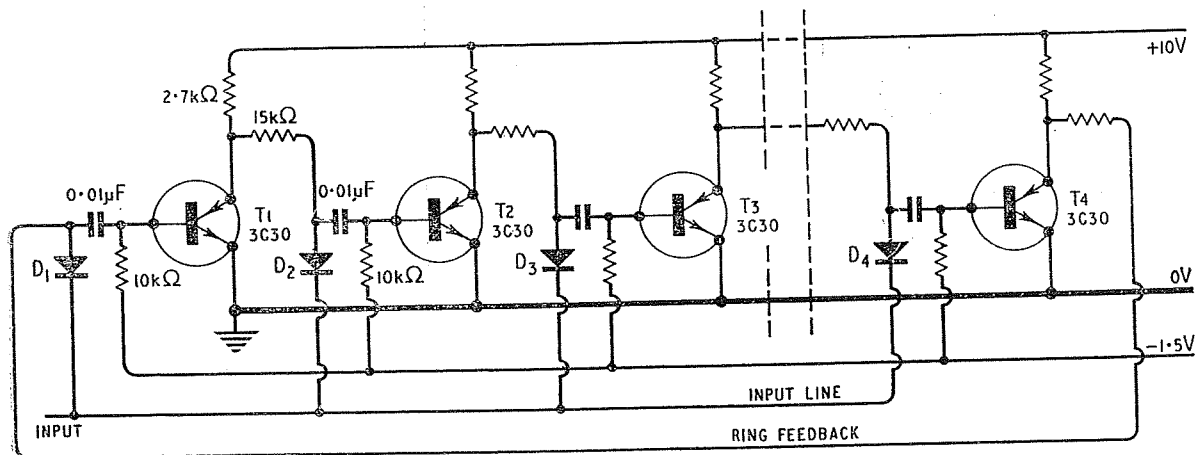

Fig. 8.31 A Trigistor ring circuit. Component values are shown in the first stage

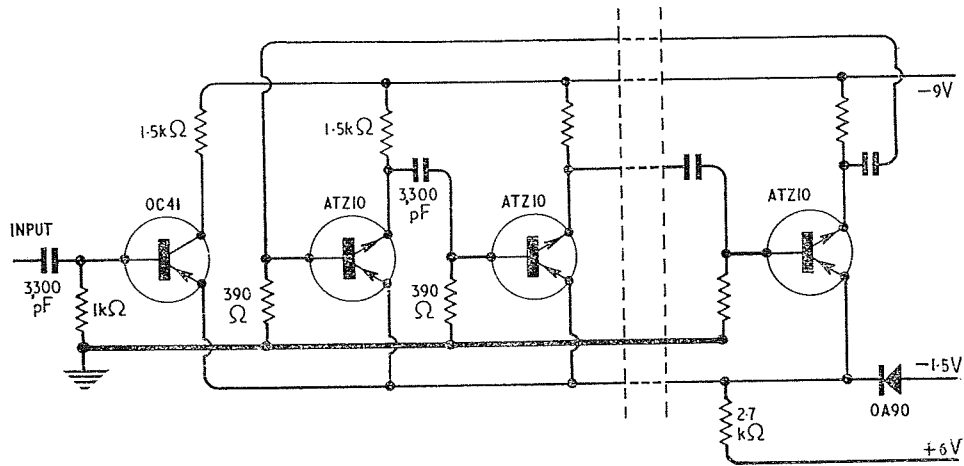

Fig. 8.32 A 30 kc/s ring circuit

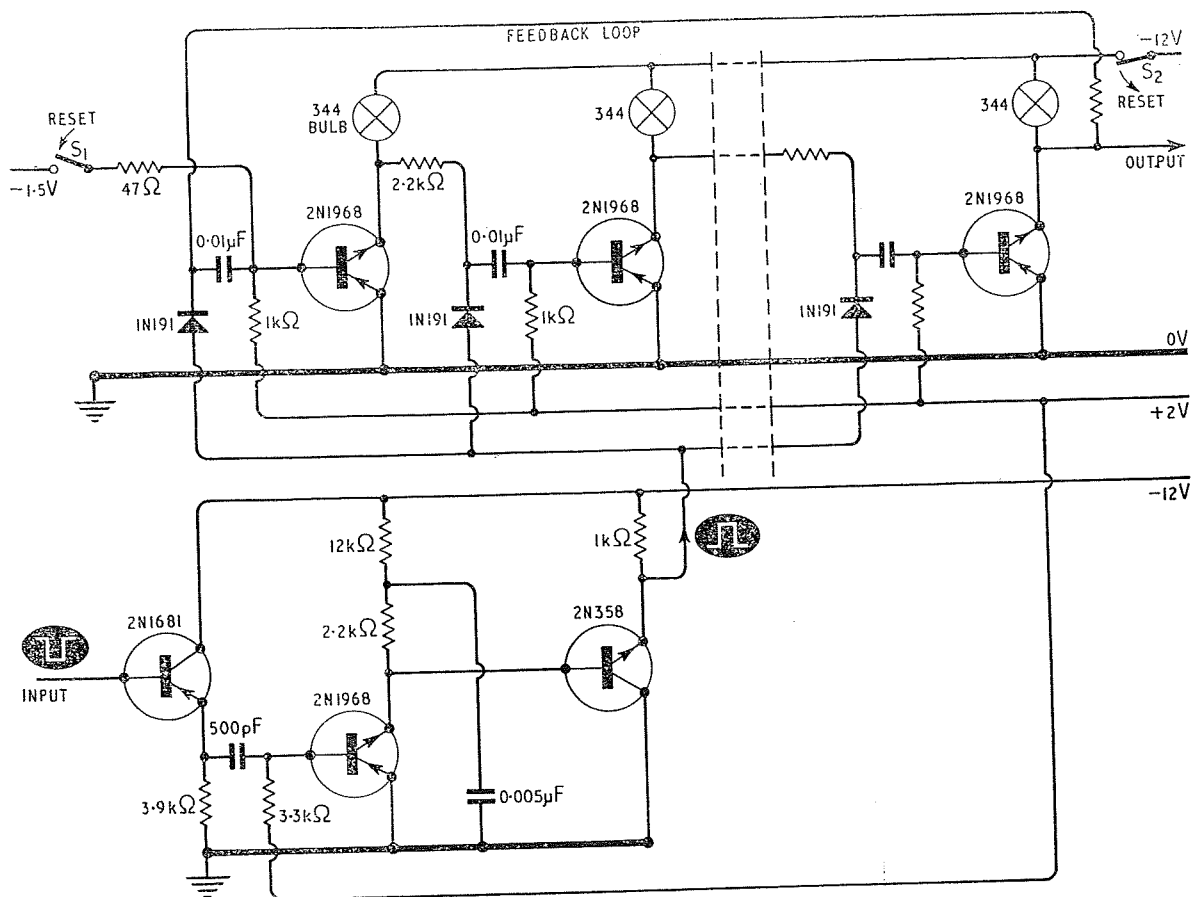

Fig. 8.33 A 20 kc/s Dynaquad ring counter

ANIC COUNTING CIRCUITS

Controlled rectifiers (also P gate) can be used in ring circuits for switching many amps at up to at least 1 kc/s⁽⁴¹⁾.

Called 'Dynaquad' is a germanium PNPN device with a connection to the inner N layer (N gate). It may be used in the type of ring counter shown in Fig. 8.33⁽⁴²⁾. The input pulses are fed into a 2N1681 emitter follower and the low impedance output from this stage is used to operate a 2N1968 Dynaquad monostable circuit which provides pulses of an 8 μ sec duration. These pulses are directly coupled into a 2N358 NPN emitter follower which provides a low impedance output for the ring circuit. The positive going pulses can switch off a conducting stage, since Dynaquads have N gates. When a conducting stage is turned off, a negative pulse is formed which is used to switch the next stage to conduction. The 344 indicator lamps are rated at 10 V, 14 mA. The maximum frequency is about 20 kc/s.

The circuit may be reset by first momentarily opening S_2 ; this cuts off the power supply and turns all of the Dynaquads off. If S_1 is now closed for a moment, the negative current passing to the N gate of the zero Dynaquad will switch it to the low resistance state.

8.2.3 The Silicon Controlled Switch

The symbol for the four terminal silicon controlled switch is shown in Fig. 8.34. G_A is the N gate and G_C is the P gate. G_A is the layer next to the anode. These switches may be used in ring circuits of the

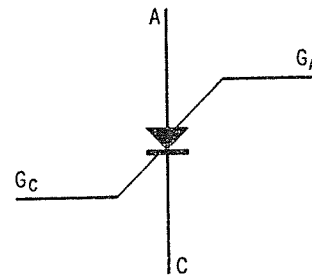

Fig. 8.34 The symbol for the silicon controlled switch

type shown in Fig. 8.35⁽²³⁾. D is a zener diode with a working voltage of between 3 and 6 V.

The 4.7 k Ω anode resistor is chosen so that only one stage can conduct at any time. A positive going input pulse of about 10 μ sec duration will cause the NPN input amplifier, T_1 , to conduct and this will reduce the potential of the common anode line so much that the conducting silicon controlled switch will be turned off. This results in a positive going pulse being formed at the anode gate which can be fed to the cathode gate of the succeeding stage and the latter is thus switched to the low resistance state. When the final stage is switched off, the common anode potential rises until the zero stage is turned on by the current passing through the zener diode. This circuit has the advantage that it is automatically set to zero when the power supply is first applied.

8.3 TUNNEL DIODE COUNTING CIRCUITS

The operation of the tunnel diode, unlike that of the transistor or the PNP device, does not depend on

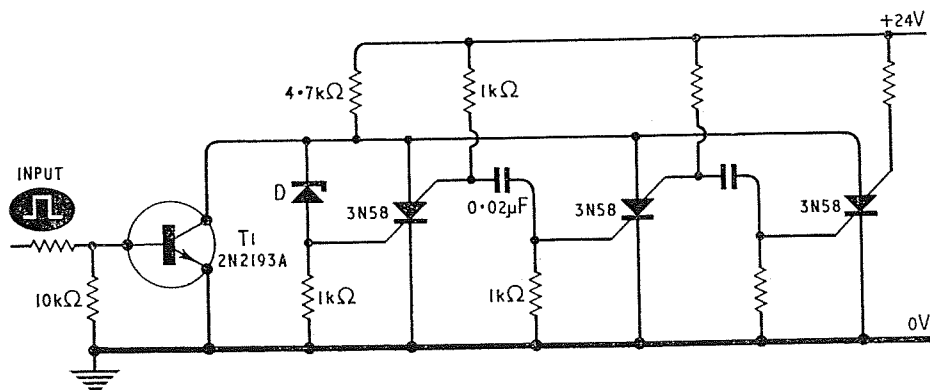

Fig. 8.35 A silicon controlled switch ring counter

the relatively slow diffusion of minority carriers across a field free region, but utilises the passage of majority carriers at a high velocity across a narrow junction. Transit time effects are therefore negligibly small and the tunnel diode is capable of operating at very high speeds. The switching time is a function of the junction capacitance and the negative resistance. Tunnel diodes can operate at a much smaller power than transistors and are ideal for use in miniature equipment. The design of tunnel diode circuits is simplified by the fact that the spread of some of the parameters can be made much smaller than in the case of transistors.

The tunnelling effect in semiconductors is a fairly recent discovery⁽⁴³⁾ and it is probable that new ways of using tunnel diodes in counting circuits will be developed in the future. Many different types of tunnel diode counting circuits can be constructed, but at the moment they are not very widely used. One of

rises, the current first rises to a maximum, then falls to the valley region and finally rises again. The diode exhibits a negative incremental resistance in the section of the curve in which the current decreases as the voltage increases. If the tunnel diode is connected to a load resistor which has a value somewhat greater than the negative resistance of the diode, a supply voltage can be chosen which will enable the load line to cut the characteristic in three places as shown in Fig. 8.36. The point *B* in the negative resistance region is unstable, but the circuit can be switched from the stable low voltage state at *A* to the stable high voltage state at *C* if a pulse is applied to increase the voltage across the diode. A pulse of the opposite polarity will switch the operating point back to *A*. A single tunnel diode can, therefore, be used as a bistable circuit if pulses of alternating polarity are available.

8.3.1 Bistable Circuits

A tunnel diode bistable circuit which can be operated from input pulses of constant polarity is shown in Fig. 8.37. This type of circuit is known as a Goto counter. The supply voltage is chosen so that only one of the diodes can be in its high voltage state at any time. The difference between the currents taken by the diodes passes through the inductance *L*. A positive going input pulse of suitable amplitude will switch the diode which is in the low voltage state to the high voltage state. The current passing through the inductance then falls and a voltage is induced across it which is of the correct polarity to switch the

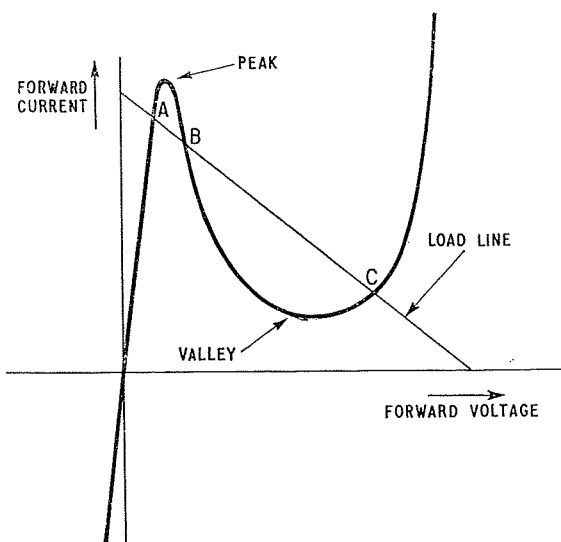

Fig. 8.36 The tunnel diode characteristic curve

the main difficulties being encountered is that of cascading tunnel diode circuits, since a tunnel diode does not provide a very suitable current source for driving a succeeding tunnel diode circuit. For this reason tunnel diodes are often used with transistors. Tunnel diodes lack the flexibility of most other active components because they have only two connections.

The characteristic curve of a tunnel diode is shown in Fig. 8.36. As the voltage applied across the diode

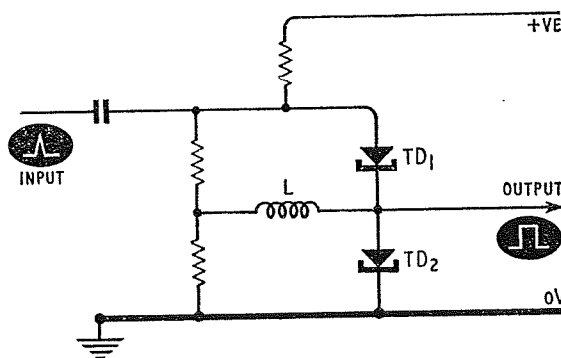

Fig. 8.37 A Goto binary circuit

ELECTRONIC COUNTING CIRCUITS

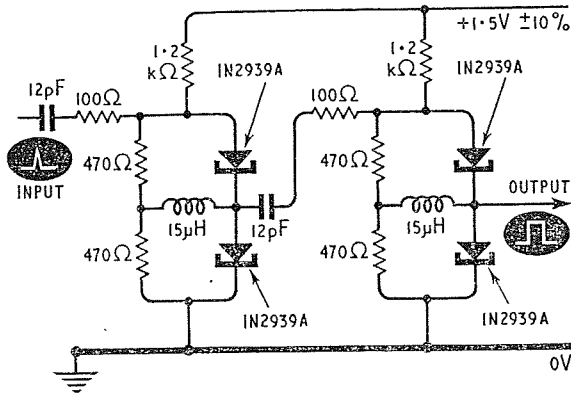

Fig. 8.38 A scale of four circuit using Goto binaries

other diode from the high to the low voltage state. A second input pulse will return the circuit to its initial state by a similar process.

A practical scale of four circuit for use at frequencies up to 10 Mc/s is shown in Fig. 8.38⁽⁴⁴⁾. The input pulses to the 1N2939A tunnel diodes should have an amplitude of 0.5 to 0.7 V and a duration of 1/100 μsec at 10 Mc/s. The output pulses have an amplitude of 0.4 V. A similar circuit using two directly coupled tunnel diode bistable circuits has been published which will operate at frequencies up to 200 Mc/s⁽⁴⁵⁾.

Direct coupling of Goto counters is not always very satisfactory and there is some advantage in the use of transistor coupling circuits. The Goto circuits may be used with carry gates for high speed counting as shown in Fig. 8.39(a)⁽⁴⁶⁾. Any counter stage will not receive an input pulse unless all of the

previous carry gates are open. A carry gate will not be open if the Goto circuit to which it is connected is in the zero state. Fig. 8.39(b) shows the basic circuit of a carry gate using two NPN transistors. The output from the Goto circuit controls the current passed by T1 and this transistor is coupled to T2 so that the latter is either saturated or cut off. If it is saturated there is effectively a short circuit between its emitter and collector and the trigger pulse is propagated to the succeeding stages without any more delay than that caused by the wiring, since the pulses do not have to pass through any of the preceding binaries. Eight successive carry gates may cause a delay of about 10⁻⁹ sec. If a Goto circuit is in its zero state, T2 of the corresponding carry gate will be cut off and the input pulse will not be able to pass to the succeeding stages.

The first input pulse cannot pass through the left-hand carry gate of Fig. 8.39(a), since the Goto circuit shown beneath this carry gate is in its zero state. However, this Goto binary will be switched by the input pulse so that a count is registered. The switching of this binary opens the first carry gate. The second input pulse will switch the first Goto circuit to zero and will pass through the first carry gate to switch the second Goto binary. However, the second carry gate is closed, so the pulse cannot pass to any other stages. A binary count of two is thus registered. The third input pulse can switch only the first binary, since the first carry gate is closed. Thus a binary count of three is registered. The fourth pulse switches the first binary to zero, The fourth pulse switches the first binary to zero,

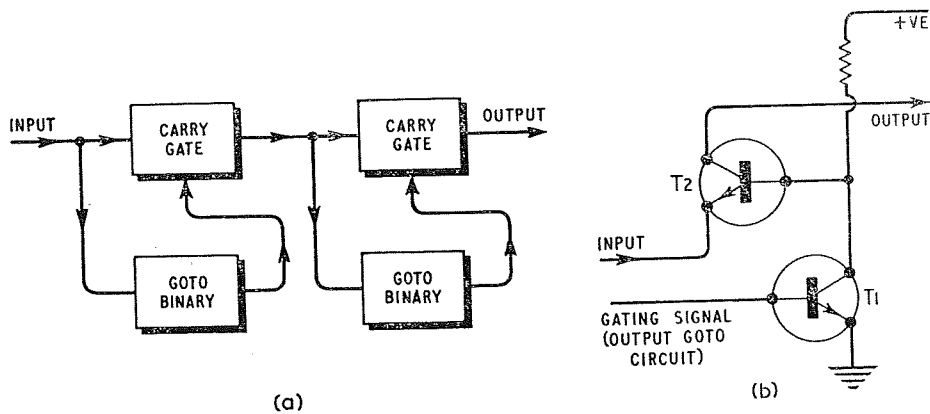

Fig. 8.39 Fast counting with transistor gated Goto binaries

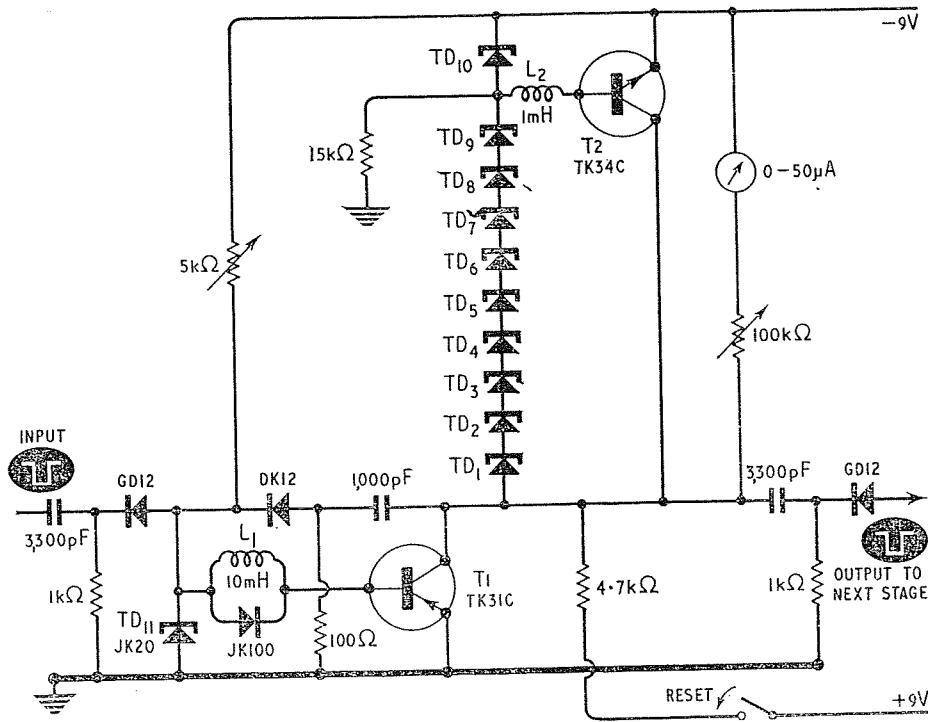

Fig. 8.40 A tunnel diode current switched decade

passes through the first carry gate to switch the second binary to zero and passes through the second carry gate to provide an output pulse for the operation of any succeeding binaries. Thus the system counts on the normal binary scale.

8.3.2 Tunnel Diode Chain Circuits

A number of tunnel diodes may be connected in series and used in a circuit which enables each input pulse to switch one diode from the low to the high voltage state. When all of the diodes have been switched, a transistor is usually used to return them all to the low voltage state.

In one type of chain circuit the tunnel diodes used are carefully selected so that their peak currents vary over a range of values. For example, they may range from 5 to 10 mA in increments of 0.5 mA. In this case a constant bias of less than 5 mA but greater than the valley current of any diode would be passed through the chain. When the diodes are all in their low voltage state, the circuit will be at zero. The input consists of a current of increasing ampli-

tude which passes through the tunnel diode chain and which switches the first diode and then falls to zero. The next input pulse switches the diode with the next higher peak current.

A decade counter of this type is shown in Fig. 8.40⁽⁴⁷⁾. It employs eleven tunnel diodes and provides meter readout. The tunnel diodes TD_1 to TD_{10} inclusive are selected for increasing peak currents from 6 to 10 mA. The JK100 is a backward diode. The input pulses should be negative going 5 mA current pulses with a maximum duration of 10 μ sec. The input impedance depends mainly on the impedance of the input diode; it may be as low as 30 Ω . The circuit can count at frequencies up to about 1 Mc/s, the limiting factor being the rapidity with which the resetting operation can be carried out.

The input pulses are used to switch the tunnel diode TD_{11} to its high voltage state. The change of potential at the cathode of this diode drives an exponentially rising current through the inductance L_1 into the base of the TK31C transistor amplifier, T_1 . The output from this transistor passes through the diode chain TD_1 to TD_{10} . When the diode with

ELECTRONIC COUNTING CIRCUITS

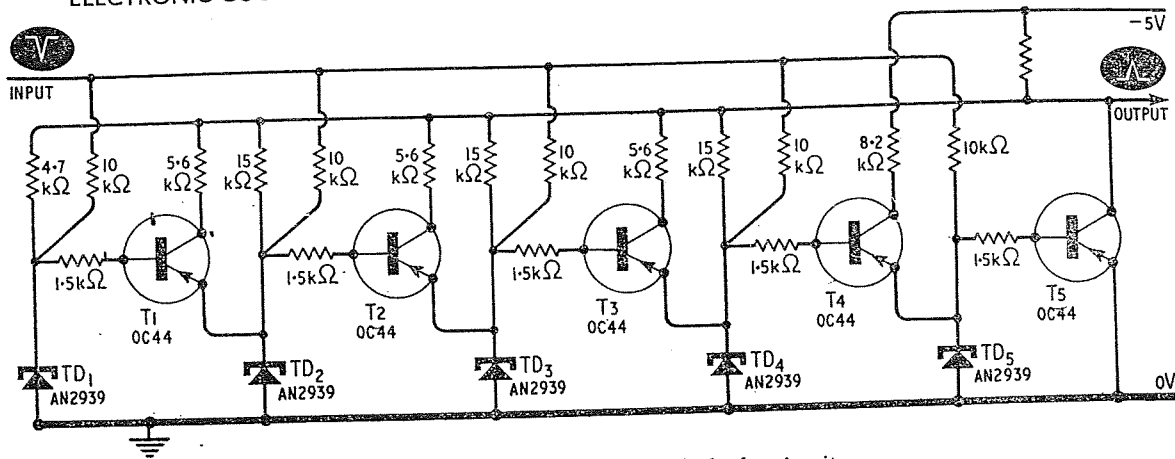

Fig. 8.41 A five stage tunnel diode circuit

the lowest peak current changes its state, the anode of TD_1 becomes more positive and a pulse is applied through the DK12 diode to return TD_{11} to its low voltage state. L_1 is bypassed by a backward diode to obtain a high speed resetting action. TD_{10} has the highest peak current and is therefore the last diode to change its state. When it is switched by the tenth input pulse, a positive pulse is applied to the base of the NPN transistor T_2 which therefore conducts and effectively short circuits the tunnel diode chain. Thus the ten diodes are reset to their low voltage state. The $15\text{ k}\Omega$ resistor connected between earth

and the junction of TD_9 and TD_{10} ensures that TD_{10} is the last diode in the chain to be reset. L_2 delays the resetting operation until the current in T_1 has ceased to flow. The reset pulse from T_2 is also used as the output but is prevented from reaching TD_{11} by the DK12 diode.

In another type of circuit⁽⁴⁸⁾ voltage input pulses are applied through a capacitor to the tunnel diode chain and the pulse amplitude is chosen so that a pulse can cause only one diode to switch. The diodes are not specially selected and normally the diode with the least junction capacitance will switch first.

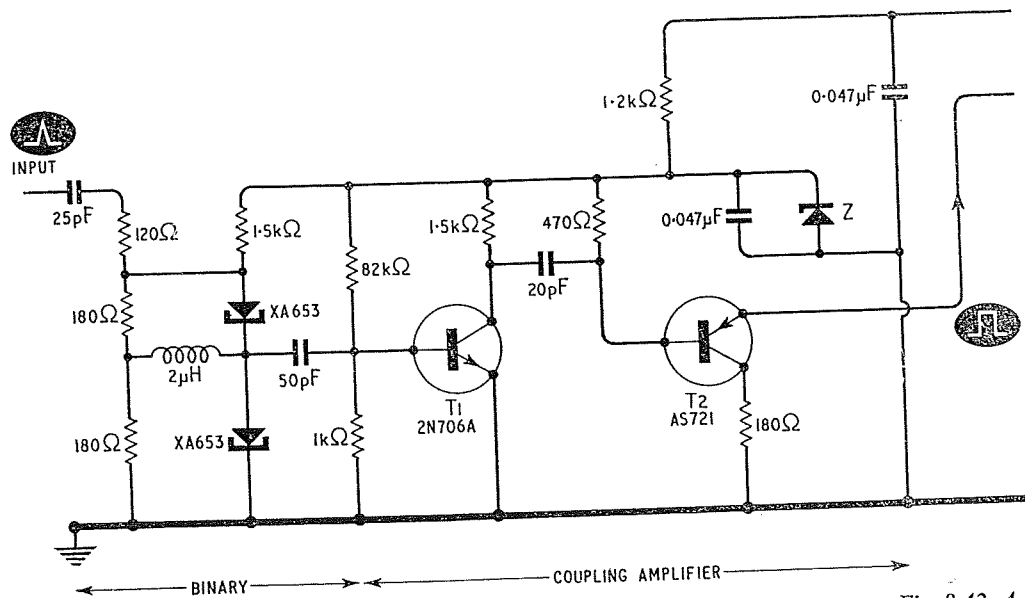

Fig. 8.42 A tunnel

The double pulse resolving time is less than 14×10^{-9} sec, but the resetting operation takes about 50×10^{-9} sec. Two transistors are used in the reset circuit.

Rabinovici has designed a decade counter using only four tunnel diodes in a decimal coded binary system⁽⁴⁹⁾. The tunnel diodes used must have parameters which satisfy certain relationships if the ten stable states are to be obtained using only four diodes.

8.3.3 Ring-like circuits

Few tunnel diode ring circuits have been published up to the present time. A five stage ring-like circuit which uses germanium tunnel diodes and consumes only about 10 mW of power is shown in Fig. 8.41⁽⁴⁵⁾. The maximum frequency of operation of this circuit is limited to about 0.5 Mc/s by the characteristics of the transistors used.

Initially all of the tunnel diodes are in their low voltage states. A negative going input pulse will switch TD_1 only to the high voltage state because this diode is receiving a larger bias current than the other diodes owing to the smaller value of its load resistor. The potential of the cathode of TD_1 becomes more negative and the transistor $T1$ is switched into the conducting state. The next input pulse can

switch TD_2 into its high voltage state, since this diode is now biased by the current passing through $T1$. Hence $T2$ is switched to conduction and the third input pulse can switch TD_3 . When TD_5 is switched by the fifth input pulse to its high voltage state, $T5$ conducts and virtually shorts all of the tunnel diodes to earth. They therefore return to the low voltage state and the circuit has been reset to zero.

This circuit differs from the conventional ring counter in that the diodes which have been switched remain in their high voltage state until the whole circuit is reset. Negative going input pulses of 3 V amplitude are required. The output pulses are positive going and of the same amplitude.

A 20 Mc/s decade scaler is shown in Fig. 8.42⁽⁴⁵⁾. The circuit comprises a binary employing two XA653 gallium arsenide 5 mA tunnel diodes followed by a five stage counter using XA650 Texas Instruments gallium arsenide tunnel diodes. The functioning of the scale of five circuit is similar to that of Fig. 8.41, but the tunnel diode connections have been inverted for operation from a positive power supply and positive going input pulses. Coupling transistors are not required in the scale of five, but an NPN 2N708 transistor, $T3$, is used to reset it. $T1$ and $T2$ are coupling amplifiers, $T2$ being connected as an emitter follower to provide the low

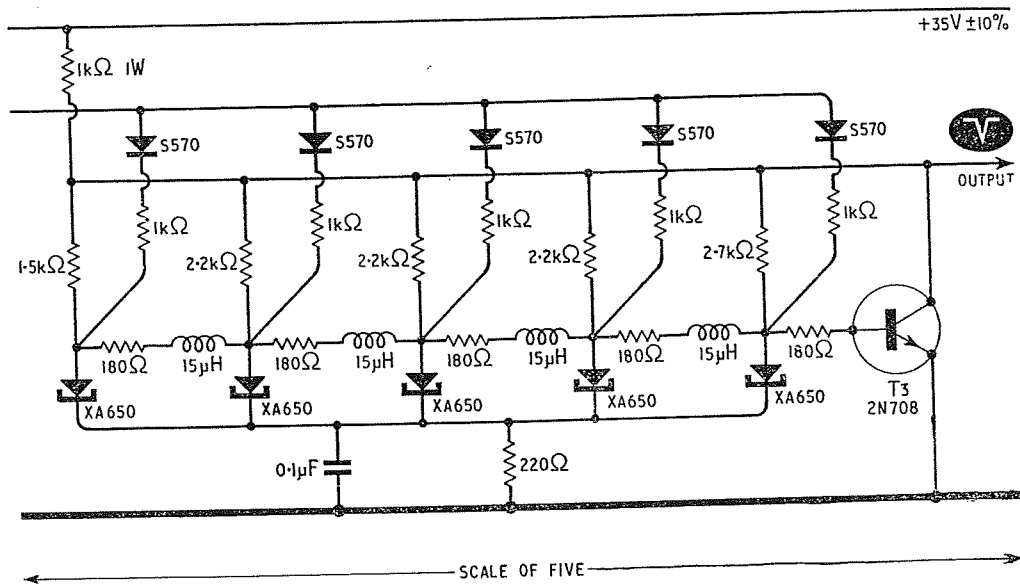

diode decade circuit

impedance output which can operate the scale of five. The input pulses should be positive going and of amplitude 0.4 V, whilst the output pulses are negative going of amplitude 6 V.

8.4 CIRCUITS USING MAGNETIC OR FERRO-ELECTRIC MATERIALS WITH RECTANGULAR HYSTERESIS LOOPS

Magnetic materials can be produced which have a hysteresis loop which is approximately rectangular in shape as shown in Fig. 8.43. If a coil is wound around a toroid of such material, the direction of magnetisation may be switched from $-B_{sat}$ to

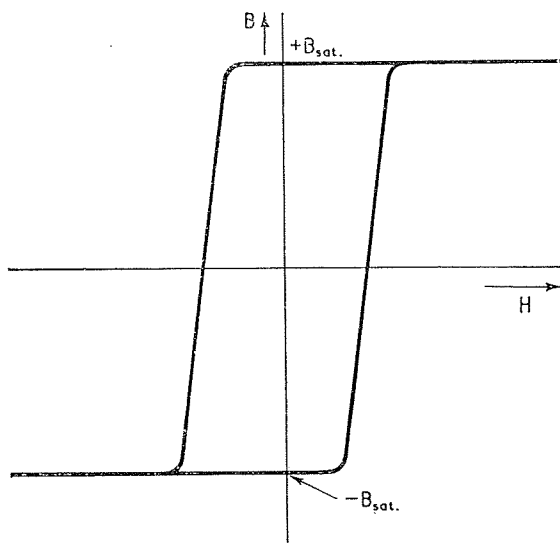

Fig. 8.43 A rectangular hysteresis loop

$+B_{sat}$ by passing a suitable current pulse through the coil. A current pulse of the opposite polarity will return the toroid to its initial state. Binary and ring counters can be constructed using this type of bistable circuit.

If the current pulses applied to a magnetic core have a duration which is smaller than the time required for the direction of magnetisation of the core to be reversed, the state of the core will change only a part of the way from $-B_{sat}$ to $+B_{sat}$. A number of pulses must therefore be applied to the circuit before the direction of magnetisation is completely reversed and several stable intermediate

states can thus be created. Scaling circuits which use these states of increasing flux for counting are known as flux counters.

Magnetic cores have been widely used as memory devices in computers and can retain information even if the power supply to the apparatus is switched off, but up to the present time they have not been

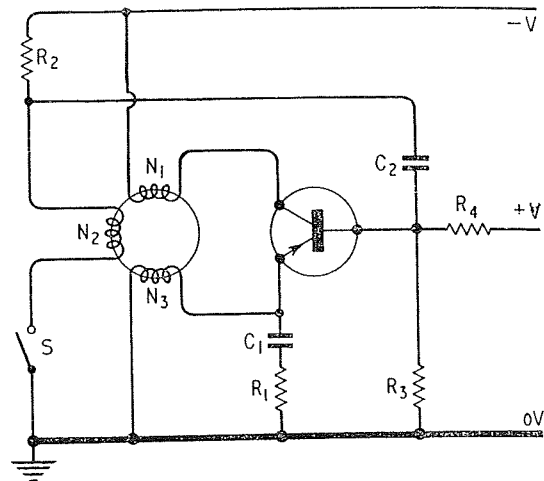

Fig. 8.44 A simple flux counter

used very frequently for pure counting. This is partly due to the difficulty of arranging readout systems for magnetic core counters. Magnetic core counters do, however, have the advantages that they require relatively few components, normally consume negligible power during quiescent periods and are very small and reliable. They are very suitable for use in space vehicles⁽⁵⁰⁾.

Transistors are very suitable for controlling the current pulses to magnetic cores, since their low output impedance can easily be matched to the impedance of the core winding. Normally the transistors are used in a blocking oscillator circuit, the magnetic material being used as the transformer core. The circuits require rather careful design⁽⁵¹⁾.

Relatively simple decade counters, such as that shown in Fig. 8.44, can be designed using magnetic cores⁽⁵²⁾. S is an electronic switch which generates the input pulses. Each current pulse must be so short that it causes only a partial reversal of the direction of magnetisation as it flows through N_2 and R_2 . If the operating point on the hysteresis loop

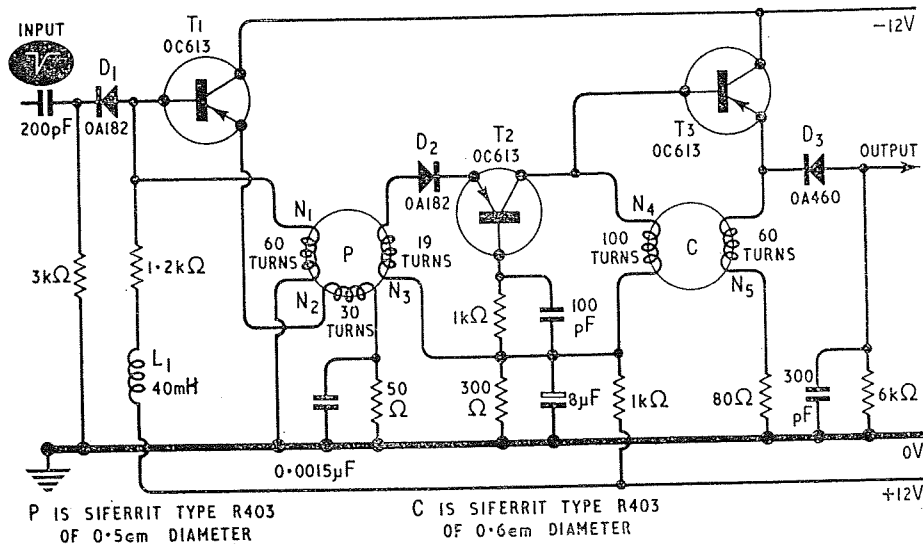

Fig. 8.45 A practical magnetic flux decade counter

is initially at $-B_{\text{sat}}$, successive input pulses will cause it to move by degrees to $+B_{\text{sat}}$. The coil inductance has now decreased, since a further input pulse can cause little increase in the magnetic induction. Once saturation has been reached, almost all of the input voltage of the next pulse will appear across R_2 instead of across N_2 . The pulse from R_2 is differentiated by $C_2 - R_3$ and is used to switch the transistor to conduction. A current passes through N_1 and the operating point is returned to $-B_{\text{sat}}$. Although this circuit will function reliably, it is only satisfactory over a temperature range of about 4°C , since the magnetic properties of the core are very temperature dependent.

In order to construct a magnetic counter which can be operated over a reasonably wide temperature range, it is almost essential to employ two cores which have very similar temperature dependencies⁽⁵²⁾. In one type of circuit the input pulses are fed to a 'pumping' core which is taken through a complete magnetic cycle for each input pulse applied to the circuit. A winding on the pumping core supplies pulses to a coupling circuit which operates the second core which is known as the counting core. Each input pulse only partly reverses the direction of magnetisation of the counting core, but after a number of pulses have been applied the core becomes saturated in the opposite direction to its initial state; it is then returned to its zero state.

A practical counter circuit based on this principle is shown in Fig. 8.45; two blocking oscillators are used⁽⁵²⁾. A bias current passes through N_1 and the $1.2\text{ k}\Omega$ resistor. This current is capable of returning the pumping core, P , to its quiescent state. A negative going input pulse will trigger the first blocking oscillator and the direction of magnetisation of the core P is momentarily reversed. The output from P supplied by N_3 is amplified by T_2 and is used to partly change the state of the counting core, C . When C becomes saturated, the transistor T_3 is triggered by the difference in voltage between N_4 and N_5 . T_3 is normally cut off by the positive potential applied to its base.

The maximum frequency of operation of the circuit shown is about 128 kc/s and is limited by the rapidity with which the cores return to their quiescent state. If L_1 is omitted the pumping core takes longer to return to its quiescent state and the maximum frequency is limited to about 40 kc/s . The operation of the circuit is almost independent of temperature. The scale in which the circuit counts can be altered by varying the number of turns on the core windings or by varying the values of the resistors in the coupling circuit. The counting capacity may be changed very conveniently, however, by bringing a small permanent magnet near to the pumping core to increase the capacity or near to the counting core to reduce the capacity. The

ELECTRONIC COUNTING CIRCUITS

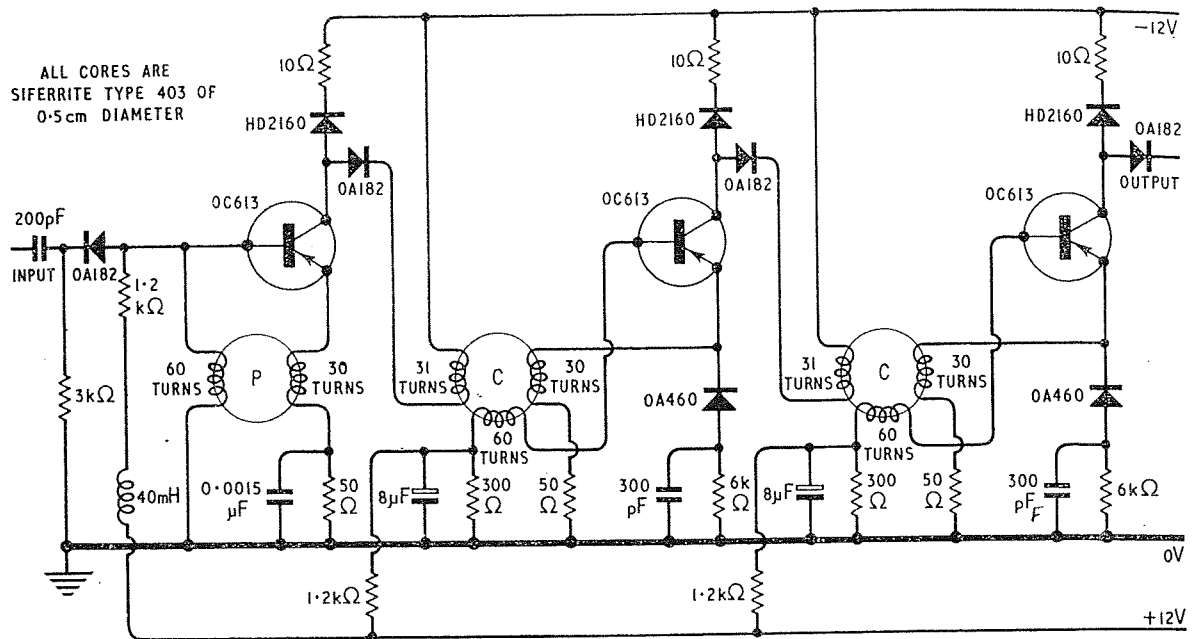

Fig. 8.46 A two decade magnetic flux counter

count capacity may easily be varied from 6 to 16 by this method⁽⁵²⁾. It is necessary to have some control over the count capacity to overcome the effects of component tolerances.

It is not essential to use two cores in any decade after the first, since the counting core of the first decade yields a temperature dependent signal and acts as a pumping core for the next decade. A two decade counter employing only three magnetic cores is shown in Fig. 8.46⁽⁵²⁾. A simplified method of coupling is employed in this circuit so that only one transistor is required in any decade after the first.

These circuits are excellent frequency dividers, but the problem of providing a method of readout for them is a difficult one, since the information on the state of the count is contained in the magnetic flux of the cores. There is no known method of providing readout without interfering with the counting process. If the decades are separated from each other by gates, at the end of the counting process the number of additional pulses from a pulse source required to bring about saturation in each of the cores may be found; this is the complement of the number counted. In an alternative method of

readout, the decades are again separated by gates and ten pulses are applied to each decade; the number of pulses arriving at each decade after that decade has saturated are counted on a separate instrument.

A number of other flux counter circuits have been published^(50, 53-55) in addition to full details of the principles of operation⁽⁵⁶⁾.

8.4.1 Magnetic Readout

An interesting ring type of decade scaling system with magnetic readout has been developed at Harwell⁽⁵⁷⁻⁵⁸⁾. Basically this system consists of ten rod like magnetic cores placed in a circle with their longitudinal axes perpendicular to the plane of the circle. They have rectangular hysteresis loops. A pivoted spindle passes through the centre of the cylindrical arrangement and two compass needles are connected astatically at each end of the spindle. At any one time nine of the cores are magnetised longitudinally in one direction, whilst the tenth core is magnetised in the opposite direction. Each input pulse causes two cores to be switched so that another core is now magnetised in the opposite

direction to the other nine cores. The pattern of magnetisation is thus rotated one place by each input pulse. One pole of each of the compass needles is attracted by the core which is magnetised in the opposite direction to the others and is repelled by the other nine cores. The compass needles, therefore, follow the rotation of the magnetic pattern at low counting speeds, but at high speeds they will come to rest at the correct place a very short time after the counting has ceased. A pointer attached to the spindle to which the compass needles are fixed shows the state of the count; it will continue to do this even after the power supply has been cut off. The resolving time of the system can be made less than $1 \mu\text{sec}$. In the quiescent state the only power consumed is about $100 \mu\text{W}$ per decade (at 20°C) to supply the transistor leakage current. An additional power of about $3.5 \mu\text{W}$ per count per second is required when counting is taking place. A 15 V power supply is used.

The spindle is mounted in jewelled pivots of the type used in microammeters. It is operated in oil, the viscosity of which is chosen to give a suitable mechanical damping. Decades constructed on these principles have been made in cylinders $2 \frac{3}{16}$ in. diameter and 6 in. long. The front face houses the indicator needle which may be compared with the hand of a watch. The face is marked with the digits 0 to 9.

In the later version the cores consist of films of nickel-iron alloy deposited electrolytically on 13 s.w.g. copper rods. It is necessary to apply a magnetic field during the deposition in order to produce a preferred direction of magnetisation which results in a rectangular hysteresis loop. The magnetic films have a thickness of 1.8×10^{-4} cm.

The cores are driven by XA112 transistors used in a type of blocking oscillator circuit. Each transistor switches two of the cores once during the time ten input pulses are applied to the decade. An input pulse triggers only the transistor whose core is magnetised in the opposite direction to that of the other cores. The transistor conducts until the core is magnetised in the same direction as the others and also provides a pulse which switches the succeeding core. Inter-decade coupling circuits using one transistor and one core with a rectangular hysteresis

loop are used. The same circuit can be employed to trigger the first decade at input frequencies up to 100 kc/s , but at higher frequencies a bistable input circuit is used.

8.4.2 Circuits Using Ferro-electric Capacitors

Ferro-electric materials can be considered to be the electrical analogues of ferro-magnetic substances and are used as the dielectric in capacitors. If the polarisation of such a capacitor is plotted (on the vertical axis) against the potential applied across the capacitor, a rectangular hysteresis loop similar to the magnetic hysteresis loop of Fig. 8.43 can be obtained⁽⁵⁹⁾. Thus when a voltage pulse is applied to a ferro-electric capacitor, the capacitor does not return to its initial state at the end of the pulse.

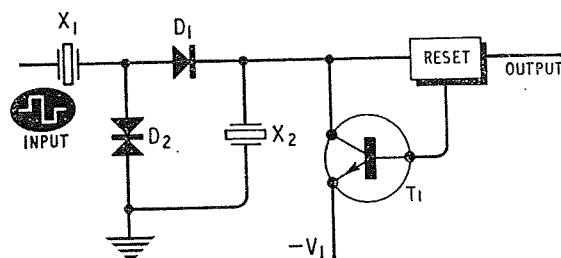

Fig. 8.47 A counting circuit employing ferro-electric devices

The displaced charge can remain in the dielectric for a long time, but readout difficulties similar to those encountered with magnetic counters arise.

The ferro-electric crystals, like ferro-magnetic materials, contain domains and there is a Curie temperature above which the ferro-electric properties disappear. Possibly the most useful ferro-electric material is barium titanate, but a number of others such as potassium niobate and guanidine aluminium sulphate hexahydrate are known.

If a potential is applied to a ferro-electric capacitor, the device behaves more or less as a small resistor in series with a fixed potential. As soon as it is completely polarised, however, it behaves as a capacitor of very small value.

The basic type of counter in which ferro-electric capacitors may be used is shown in Fig. 8.47⁽⁶⁰⁾. When the positive part of the input pulse is applied to the circuit, the ferro-electric capacitor X_1 has

its direction of polarisation completely reversed and the charge which passes through it also passes through D_1 to the ferro-electric capacitor X_2 . The charge passed to X_2 is almost independent of the size of the input pulse provided that this exceeds a certain minimum value, since once X_1 has completely switched it behaves as a very small capacitor and an increase in the input pulse voltage will not appreciably increase the charge passed to X_2 . X_2 is several times larger than X_1 and its polarisation will therefore only be partly reversed by the charge from X_1 . The negative going part of the input pulse returns X_1 to the zero state, the current passing through the double anode breakdown diode D_2 which is equivalent to two silicon diodes mounted back to back.

The next input pulse will switch X_1 again and cause the same charge to be fed to X_2 as before. After a number of input pulses X_2 will saturate (become fully polarised) and a further input pulse will now cause the voltage across X_2 to increase

considerably. The reset circuit is thus triggered and a positive pulse is fed to the base of the NPN transistor $T1$. The transistor conducts and the negative voltage $-V_1$ is applied to the upper end of X_2 which is thus switched to its initial state of polarisation.

If X_2 is ten times the size of X_1 , a decade counter is formed. This type of circuit has been used for counting in scales of up to 40. The switching time is small and the pulse spacing may range from a few microseconds to some days. The maximum counting frequency is limited by the heat dissipation in X_1 .

Similar types of circuit have been proposed⁽⁶¹⁾ in which ordinary capacitors are used for X_1 and X_2 , but such circuits have several disadvantages. The charge passed from X_1 to X_2 is not independent of the input pulse voltage, the counting capacity must be fairly small and the pulse spacing should not exceed about 5 msec owing to leakage of charge from X_2 .

REFERENCES

1. P. JAMES & A.F. NEWELL, 'Switching times for alloy junction transistors' *Mullard Technical Communications*, **5**, 44, 159 (1960).
2. C. LE CAN, 'Transient behaviour and fundamental transistor parameters' Philips Report AI 801 (3rd September 1959). Also *Electron. Appl.*, **20**, 2, 56 (1959/60).
3. G. H. GOLDSTICK, 'Comparison of saturated and non-saturated switching circuit techniques'. I.R.E. *Trans. Electron. Computers*, **EC9**, 2 (1960).
4. J. J. SPARKES & R. BEAUFOY, 'The junction transistor as a charge controlled device', *Proc. I.R.E.*, **45**, 12 (1957).
5. R. BEAUFOY, 'Transistor switching circuit design using the charge-control parameters', *Proc. Inst. Elec. Engr.*, **106B**, Suppl. 17, 1085 (1959).
6. 'The Use of Transistors as Switches', A.E.I. Report 4450-204.
7. 'Transistor Switching Parameters'. G.E.C. Semiconductor Report No. 18.
8. R. W. A. SCARR, 'The Switching Performance of Alloy Junction Transistors' Parts I and II. S.T.C. Transistor Division Application Reports Nos. MK/146 and MK/147.
9. J. J. EBERS & J. L. MOLL, 'Large-signal behavior of junction transistors' *Proc. I.R.E.*, **42**, 12, 1761 (1954).
10. J. L. MOLL, 'Large-signal transient response of junction transistors' *Proc. I.R.E.*, **42**, 12, 1773 (1954).
11. D. F. GROLLET & J. W. THURSTON, 'Measurement of desaturation time-constant', *Mullard Technical Communications*, **7**, 63, 66 (1963)
12. B. P. FARADAY & I. F. TOMBS, 'Decade Counting Circuits and Read-out Systems', Semiconductors Ltd. Application Note No. 104.
13. J. HILTEBEITEL & P. THOMAS, 'Transistor Guide for Switching Circuit Designers', Philco Corporation Application Report 691A. (Sept. 1961).
14. R. H. CHILTON, 'Binary Counting Circuits Using Alloy Junction Transistors', S.T.C. Transistor Division Application Report No. MK/144.
15. E. WOLFENDALE, *The Junction Transistor and its Applications*-Heywood and Co. (1958).
16. 'Circuit Loops No. 1.' Sylvania Semiconductor Division; B.L. NORRIS, 'A Ring Counter Circuit Using Pairs of Complementary Transistors', Texas Instruments Application Report, **1**, 8 (March 1965).
17. P. KRENTZKY, 'Decade counter employs silicon transistors', *Electronics*, **28**, 112 (1955).
18. 'Transistorised Decade Counter'. Drawing No. AC162 published by the Brush Crystal Company (1962).
19. J. E. HULL, 'A Decimal Counting Unit using 2G301-4 Transistors', Texas Instruments Application Report **1**, 7 (June 1961).
20. 'Digitron Display Tubes'. Ericsson Telephones publication no. B. 6207/2 issue 2.
21. 'The 2G103 in Saturating Binary and Decade Counters'. Texas Instruments Application Note No. 5.
22. 'ZT20 series Silicon Transistors as High Speed Saturated Switches' Ferranti Application Report No. 1002.
23. Transistor Manual, 6th Ed. Gen. Electric Co.

24. 'BIPCO Module Decimal Counter type BP-8001', Burroughs Corp. (1962).
25. F. H. WELLS & J. G. PAGE. 'Pulse counting and fast scaling transistor circuits', *J. Brit. I.R.E.*, **23**, 3, 231 (1962).
26. A. R. OWENS, A. J. COLE & P. E. DOLLEY, 'High Speed Transistor Scalers', A.E.R.E. Report R4074 (1962).
27. G. B. B. CHAPLIN & A. R. OWENS, 'A junction transistor scaling circuit with 2 microsecond resolution', *Proc. Inst. Elec. Engrs.*, **B**, **103**, **10**, 510 (1956).
28. W. Hilberg, 'Die Eccles-Jordan-Schaltung mit Transistoren für sehr schnelle Zähler', *Telefunken Zeitung*, **128**, 98 (1960).
29. A. F. FISCHMANN., 'A Gray code counter', *I.R.E. Trans. Electron. Computers*, **EC6**, 120 (1957).
30. ZOLTAN TARCZY-HORNOCH, 'Five binary counting technique makes faster decimal counting circuits', *Electronic Design*, **9**, 2, 34 (1961).
31. R. M. SCHULTZ, 'U.H.F. Counter Circuits for 0.2 Kmc Bit Rates' Fairchild Application Report App-43 (Nov. 1961).
32. J. A. HILTEBEITEL, 'A 100MC Decade Counter using the 2N769 (MADT) in Saturated Circuitry', Philco Application Report No. 708 (Nov. 1961).
33. R. L. FOGLESONG, 'The Design of High Speed All Transistor Logic Circuits', Fairchild Application Report App-49 (Dec. 1962).
34. 'Ring Counter', Sheet no. 10,001A' Clevite Transistor Corporation (20th October 1959).
35. 'Nixie', Sheet No. 10,003 Clevite Transistor Corporation (30th December 1959).
36. 'Add and Subtract Ring Counter', Sheet No. 10,002-10,002A, A Clevite Transistor Corporation (20th October 1959).
37. 'Ferranti 4-layer Switching Diodes', Application Report no. 7 (AR/112) (July 1962).
38. 'A Survey of some Basic Trigistor Circuits' Bulletin D410-02, 3-60. Solid State Products Inc. (1960)
39. E. WOLFENDALE, 'Alloy diffused transistors', *Electron. Eng.* **33**, 88 (1961).
40. E. DELL'ORO & K. P. P. NAMBIAR., 'A 100 kc/s 'Transwitch' ring counter for binary to decimal conversion', *Electron. Eng.*, **34**, 412, 402 (1962).
41. 'Controlled Rectifier Ring counters'. Transitron Application Note No. 3.
42. 'Dynaquad Decade Counter', Tung-Sol Electric Inc. Application Note 2-61 (1961).
43. L. ESAKI, 'New phenomenon in narrow Ge p-n junctions', *Phys. Rev.*, **109**, 603 (1958).
44. Tunnel Diode Manual, 1st Ed., Gen. Electric Co. (1961).
45. E. BALDINGER, U. SPYCHER AND R. BOSSART, 'Unter-setzer mit Tunneldioden', *Helv. Phys. Acta*, **35**, 4-5, 237 (1962).
46. G. B. B. Chaplin. (Private Communication.)
47. I. ALEKSANDER & R. W. A. SCARR. 'Tunnel devices as switching elements'. S.T.C. Transistor Division Application Report MK/166. *J. Brit. I.R.E.*, **23**, 177 (1962).
48. P. SPIEGEL, 'High speed scalers using tunnel diodes', *Rev. Sci. Instr.*, **31**, 754 (1960).
49. B. RABINOVICI, 'Tunnel diode decade counter', *Rev. Sci. Instr.*, **33**, 1391 (1962).
50. D. H. SCHAEFER, 'Magnetic core event counter for earth satellite memory', *Elec. Eng.*, **77**, 52 (1958).
51. W. HILBERG, 'Die Ummagnetisierung bei Ringkernen aus Rechteckferrit' *Frequenz*, **16**, **1**, 24 (1962).
52. W. HILBERG, 'Flusszähler aus Rechteckferrit-Ringkernen', *Nachr. tech. Z.*, **15**, 2, 88 (1962).
53. E. C. GEISSLER, 'Magnetic Circuitry and Applications', Sprague Technical Paper No. 62-3 (1962).
54. I.R. BACON & G.H. BAMES, 'Quantized flux counter', *IRE Wescon Rec.*, 246 (1957).
55. G. F. PITTMANN, 'A high accuracy static time delay system using transistors', *Trans. Am. Inst. Elect. Eng.*, **74**, 54 (1955).
56. G. MÜLLER, 'Der Magnetflusszähler', *Nachr. techn. Z.*, **14**, 81 (1961).
57. E. FRANKLIN, 'A self-indicating magnetic scaling system using electro-deposited nickel-iron film cores', *J. Brit. I.R.E.*, **23**, **1**, 69 (1962).
58. E. FRANKLIN & J. B. JAMES, 'Magnetic-memory scaling system with magnetic count indication'. *Nucl. Instr.*, **2**, 348 (1958).
59. W. J. MERZ & J. R. ANDERSON, 'Ferroelectric storage devices' *Bell. Lab. Record*, **33**, **9**, 335 (1955).
60. R. M. WOLFE, 'Counting circuits employing ferroelectric devices', *IRE Trans. Circuit Theory*, **CT-4**, 226 (1957). Also reprinted in Bell Telephone System monograph 3005.
61. CHANCE *et al*, 'Waveforms'. *Mass. Inst. Technol. Rad. Lab. Ser.*, **19**, 614 (1949).

Ratemeter Circuits

9:1 INTRODUCTION

Various types of ratemeter or frequency meter have been used as alternatives to scalers in radioactivity measurements for many years. They can also be used for the measurement of the frequency of a source of pulses or other waveforms. Ratemeters are rather different from the other types of counting circuits, since instead of indicating the number of pulses, they show the mean rate of arrival of the input pulses. Each individual pulse makes a small contribution to the final indication. The main advantages and disadvantages of the ratemeter may be summarised as follows⁽¹⁾.

ADVANTAGES:

1. A direct and continuous indication of the count rate is given without the necessity for any separate timing operations.
2. Any appreciable change in the count rate quickly becomes obvious unless a long time constant is employed.
3. Most commercial ratemeters provide an output which will operate a pen recorder. This is especially useful when the energy spectrum of ionising radiation is to be plotted.
4. Special types of ratemeters can be designed which have a logarithmic response, which provide automatic compensation for counts lost due to the finite resolving time or which indicate the

difference or the ratio between two pulse rates. Such instruments are very useful for some special applications.

DISADVANTAGES:

1. Ratemeters are not so accurate as scalers.
2. Ratemeters must be calibrated against scalers and the accuracy of the ratemeter is dependent on the accuracy of calibration.
3. A ratemeter does not indicate the total number of counts received in a certain time.
4. When a linear ratemeter is employed, a suitable range and time constant must be chosen.
5. In random pulse counting the statistical errors of a linear ratemeter are dependent on the counting rate.

Scalers are normally used in radio-isotope work where high accuracy is required or where the count rate does not greatly exceed the background rate. Ratemeters can be used in most other cases and are particularly useful when a direct reading or a chart indication is required and for general laboratory monitoring. In other fields ratemeters are used for frequency measurements where direct reading facilities are more important than very high accuracy.

Extremely simple ratemeters of limited accuracy can be constructed. In the simplest possible case the

input pulses may be merely fed into a meter, the movement of which is damped so that the arrival of each individual pulse does not cause an appreciable fluctuation in the meter reading. Such a simple system will obviously be of very limited accuracy, since if the pulse amplitude or duration alters, the reading will be affected. Ratemeters designed to give reasonably accurate indications of the count rate, therefore, employ a pulse amplitude limiting circuit and a pulse shaping circuit which ensure that all pulses reaching the count rate measuring circuit are uniform in amplitude and duration. The count rate measuring circuit itself may be divided into an integrating circuit and a voltage measuring circuit. The integrating circuit converts the incoming pulses into a steady output voltage, the amplitude of which is dependent on the incoming pulse frequency. The output from the integrating circuit is measured by a voltmeter circuit which indicates the pulse rate directly. The general design of ratemeter circuits has been discussed in a paper by G. D. Smith⁽²⁾.

A number of pulse shaping circuits have been used in ratemeters in the past in which a thyratron⁽³⁾ has been employed. Trigger tubes have also been employed in portable ratemeters⁽⁴⁻⁵⁾, but have now been almost entirely displaced by transistor circuits. Monostable pulse shaping circuits are sometimes used⁽⁶⁻⁷⁾, but it is necessary to adjust the length of the output pulse from the monostable circuit for each counting range provided on the instrument. If the pulses are too long, some counts will be lost at high frequencies, whilst if the pulses are too short, they will not fully charge the larger capacitors used in the low frequency rate measuring circuits. Most versatile accurate modern ratemeters normally employ a bistable pulse shaping circuit and the mean length of the square wave output then varies as the reciprocal of the pulse rate. In such a circuit, however, the rate measuring circuit receives only one pulse for each two input pulses and, therefore, a longer time constant is required at low pulse rates in order to obtain a reasonably steady meter reading, but this is not a disadvantage in random pulse measurements, since a long time constant is in any case required at low input pulse rates to smooth out the statistical variations in the count rate.

Almost all ratemeter integrating circuits consist of a 'tank' capacitor, C_t , in parallel with a leak resistor, R_t . When this circuit is fed with unidirectional current pulses, the capacitor stores charge which leaks away through the resistor. If n pulses are applied to the integrating circuit per second and each supplies a charge of q coulombs, the total charge supplied to C_t is nq coulombs per second. The potential difference across C_t increases until at equilibrium the amount of charge leaking away through R_t is equal to nq coulombs per second. At equilibrium the potential, V_e , across C_t and R_t is therefore given by

$$V_e = iR_t = nqR_t \quad (1)$$

from which it can be seen that V_e is proportional to n if q is constant for all pulses. In practice V_e is measured by a microammeter placed in series with R_t or, if greater accuracy or greater meter robustness is required, a valve voltmeter (VTVM) is connected across C_t and R_t . One of the main problems encountered is that of keeping q constant as the value of V_e alters with the pulse input rate.

It should be noted that n is the frequency of the input pulses applied to the integrating circuit itself. If a bistable pulse shaping circuit is employed, this will divide the incoming pulse frequency by a factor of two and the input frequency to the bistable circuit must be $2n$.

One possible circuit for feeding the integrating capacitor, C_t , is shown in Fig. 9.1⁽⁸⁾. A pentode which is biased to cut off in the quiescent state is employed. When positive going input pulses of controlled duration are applied to the circuit, the pentode conducts for a moment and passes a charge to C_t . The use of a pentode renders the charge passed to C_t per pulse more or less independent of the voltage across C_t , since the anode current of a pentode operated above the knee of the characteristic is almost independent of the anode voltage. This type of circuit is not used in ratemeters of the highest accuracy, since the charge passed to C_t per pulse depends on the valve characteristics, the various grid potentials and the H.T. supply voltage. In fact the ratemeter range can be changed by altering the screen grid potential.

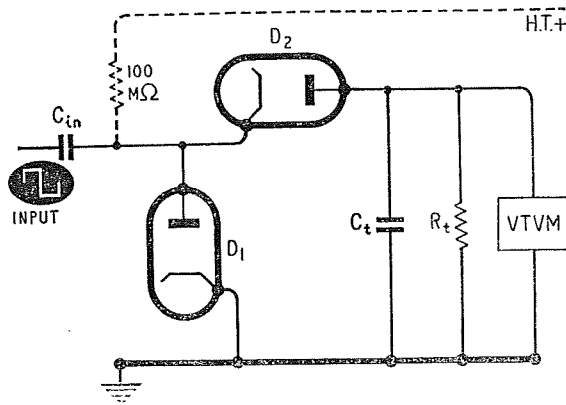

Fig. 9.1. A pentode fed integrating circuit

Almost all ratemeters of high accuracy employ the so-called 'diode pump' circuit to feed the integrating capacitor. A circuit of this type is shown in Fig. 9.2. The input capacitor, C_{in} , charges through D_1 during the positive part of the square wave input cycle. During the negative part of the input cycle C_{in} discharges through D_2 into C_t . The charge

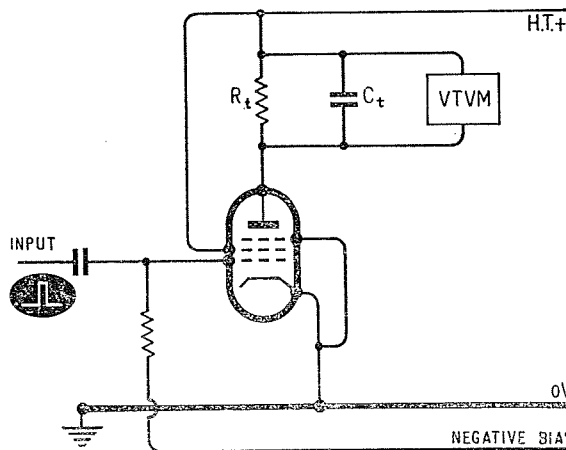

Fig. 9.2. A diode pump circuit

passed to C_t is therefore independent of the input pulse duration and of the internal resistance of the pulse source provided that the pulse duration is great enough for the capacitor C_{in} to become fully charged during the positive part of the input pulse.

As C_t charges and the potential across it increases, C_{in} will no longer pass all of its charge to C_t . The value of q will therefore vary with the input frequency and a linear scale will not be obtained. If

V_{in} is the peak to peak amplitude of the input square wave and if C_{in} is fully charged to this voltage by each pulse, the charge fed to C_t per pulse is given by the equation

$$q = (V_{in} - V)C_{in} \quad (2)$$

where V is the potential across C_t . At equilibrium $V = V_e$ and equation (2) may be substituted in equation (1), hence

$$V_e = nR_t(V_{in} - V_e)C_{in} \quad (3)$$

and

$$V_e = \frac{nR_t C_{in} V_{in}}{1 + nR_t C_{in}} \quad (4)$$

It can be seen from equation (3) that if a ratemeter with a linear scale is required, V_e must be negligible compared with V_{in} . This can be arranged if the current passing through R_t is measured by a sensitive meter, but in this case it is necessary to choose a relatively small value of R_t and hence C_t must be very large if a suitable time constant is to be obtained at low count rates. This is inconvenient because electrolytic capacitors cannot be used for C_t , since their leakage current would effectively reduce the value of R_t .

If a valve voltmeter is used to measure V_t , it is desirable that this voltage should not be less than about 10 V or appreciable errors will be introduced by the drifting of the zero of the valve voltmeter. A feedback circuit has been designed to overcome this difficulty in which a constant charge per pulse is fed to C_t , although V_e may be quite large.⁽⁹⁾

The 100 MΩ resistor shown dotted in Fig. 9.2 is often included in the circuit, since it allows a few microamps of current to flow through D_1 in the quiescent state and stabilises the anode potential of this diode. If the resistor is omitted, the anode of D_1 returns to a potential which varies somewhat with input pulse spacing at high frequencies.

When a source of pulses is initially connected to the ratemeter input, the indicated count rate will gradually rise as the charge on C_t increases until it differs from the equilibrium value, V_e , by a negligible amount. The reading of a ratemeter should not therefore be taken until the meter needle shows no further rise. The time taken for the meter indication

to reach 90% of its equilibrium value from zero is $2.3 R_t C_t$ sec. In order to limit the error to 1%, the reading should not be taken until it has reached 99% of its equilibrium value which will occur after $4.6 R_t C_t$ seconds. Thus if a ratemeter time constant is 80 sec, one should wait for over 6 min before taking a reading if 1% accuracy is required.

The time constant of the tank circuit may be made quite small if the incoming pulses are evenly spaced and if their frequency is not very small, since the integrating circuit must then merely smooth out the pulses so that the needle of the indicating meter does not fluctuate appreciably as each pulse arrives. When random pulses are being counted in radio-isotope work, however, the time constant must be chosen so that it is large enough not merely to smooth out the incoming pulses but also to smooth out the statistical variations of the pulse rate. If the input frequency is low, this demands a long time constant and there will be an appreciable delay before the meter reading alters after the input pulse rate has been changed. At higher input frequencies the statistical variations are smoothed out satisfactorily if a shorter time constant is used and advantage can then be taken of the rapid response. Many ratemeters therefore have a range of time constants.

The time constant is normally selected by trial and error so that the smallest value which gives a steady reading can be used. Most good ratemeters have circuits in which all of the tank capacitors (which determine the time constant in conjunction with the leak resistor) are charged simultaneously; a small time constant can then be selected at first to enable an approximate reading to be obtained very quickly, but after a short time a longer time constant may be used so that an accurate reading can be obtained. If all of the tank capacitors are not charged simultaneously, it is necessary to wait an appreciable time whenever the time constant is altered before another reading can be taken.

It can be shown⁽¹⁰⁾⁽¹¹⁾ that the fractional standard deviation of a single ratemeter reading at equilibrium is $1/\sqrt{2nR_t C_t}$. A single reading from ratemeter of time constant $R_t C_t$ thus has the same expected statistical error as a single counting operation carried out using the same pulse source and a

scaler for a time of $2R_t C_t$ sec. If a ratemeter is connected to a pen recorder or, if a series of readings are obtained, the statistical errors can be reduced.

9.2 PRACTICAL RATEMETER CIRCUITS

The techniques used in modern ratemeter circuitry will be illustrated by the rate measuring circuits of some well known ratemeters. With one exception all of the circuits to be discussed have been designed for radio-isotope work, but they can be used for other purposes also. The circuits show some of the wide variety of refinements which are possible in ratemeters. It should be remembered that most instruments for radio-isotope work have other circuits built into them such as pulse height discriminators or high voltage supplies for Geiger or scintillation probe units.

9.2.1 The 1021C Monitor⁽⁷⁾

The 1021C radiation monitor consists of a simple ratemeter with power supplies for Geiger and alpha scintillation probes which is intended mainly for monitoring laboratories, clothing, glassware, etc. for radio-active contamination. The accuracy of the 0-200 and 0-2,000 pulses per second ranges is $\pm 2.5\%$, but when the 0-2 and 0-20 ranges are in use, the nominal accuracy is only $\pm 10\%$. This is adequate for simple monitoring.

The basic rate measuring circuit of this instrument is shown in Fig. 9.3, but the switching of the meter to indicate the H.T. voltage or the voltage supplied to the probe has been omitted for simplicity. The input capacitor, C_1 , is used to block the d.c. voltage supplied to operate the probe and in conjunction with the resistor R_{23} it differentiates the input so that sharp pulses are obtained. $V7$ is a cathode coupled amplifier which has positive feedback from the anode of $V7a$ to the grid of $V7b$. If S_1 is in position 1 (for Geiger counting), the gain of $V7$ may be varied from 10 to 40 by $V R_2$, whereas if S_1 is in position 2, the gain is fixed at 50 for scintillation counting.

The output from $V7$ is fed into the monostable circuit of $V8$ and $V9$. In the quiescent state $V9$ is

ELECTRONIC COUNTING CIRCUITS

biased beyond cut off and $V8$ is conducting. A negative going pulse of about 1 V or more in amplitude will trigger the monostable circuit which will return to its quiescent state after a pre-set time, t . During this time the circuit is insensitive to any input pulses which may be applied to it. The duration of the time t is varied from 50 μ sec to 50 msec by factors of ten as the range switch S_{5b} is moved from position 1 to position 4. $V9$ conducts for a time t and charges the tank capacitor C_{20} . Thus, as t is increased by the range switch S_{5b} , the charge fed to C_{20} per input pulse increases and the count rate for full scale deflection is reduced. The full scale deflection on three ranges may be adjusted by means of VR_3 , VR_4 and VR_5 . The meter is protected from overloading by means of a diode. The H.T. supply is stabilised by $V5$ and $V4$, but it was found that the meter readings were dependent of the heater supply voltage. Com-

penation for variations in the heater supply voltage is therefore provided by R_{22} , R_{32} and R_{33} . If the mains voltage alters, the potential at the junction of R_{21} and R_{22} will change and this can be used to alter the pulse amplitude at the grid of $V8$.

The time constant is fixed at 1 sec (determined by C_{20} and R_{45}), but a socket is provided so that an external capacitor of about 25 to 100 μ F can be placed in parallel with C_{20} to increase the time constant to 6.25 or 25 sec respectively. The external capacitor should not be an electrolytic or its leakage resistance may reduce the reading by up to 10%.

This simple type of circuit has the advantage that there is no zero drift, since a valve voltmeter is not employed. A sensitive and therefore fairly delicate meter must, however, be used.

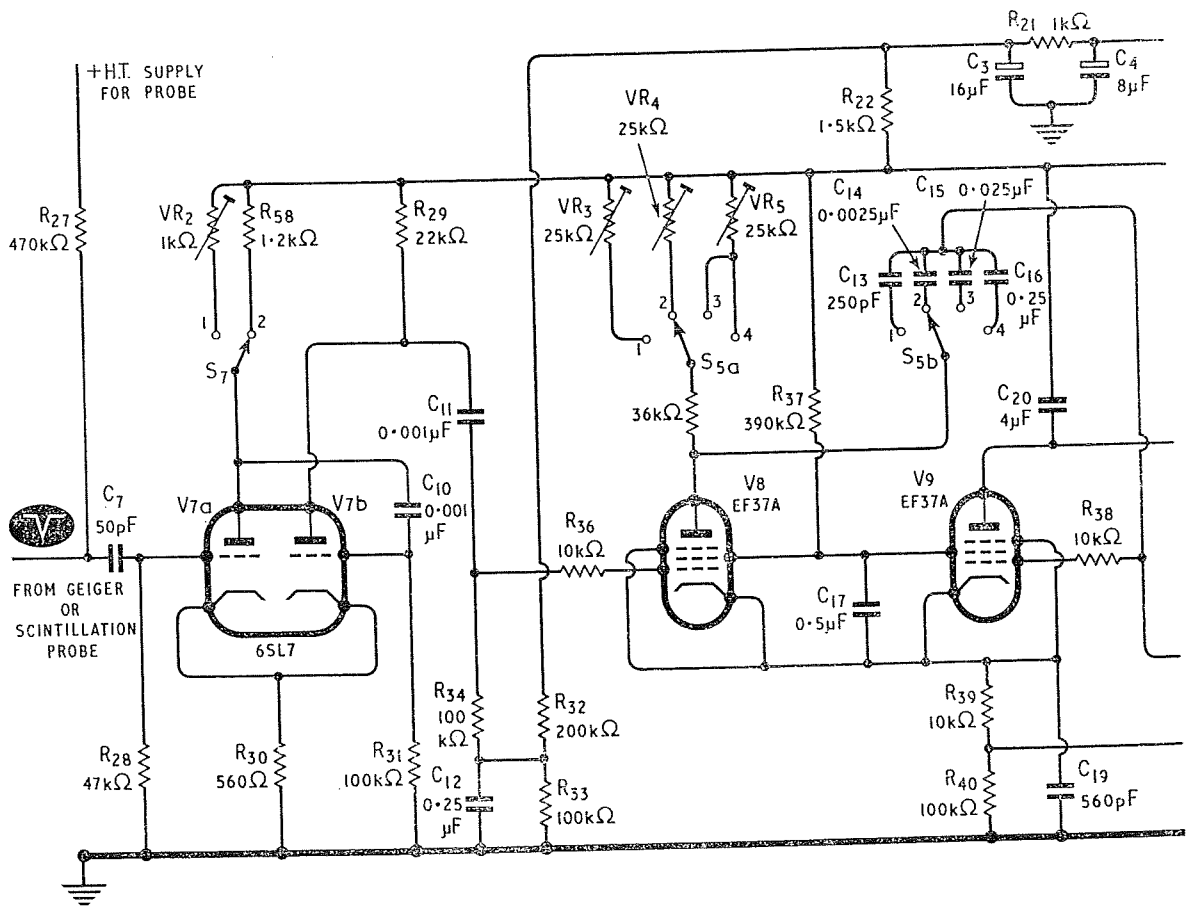

Fig. 9.3 The rate measuring circuit of

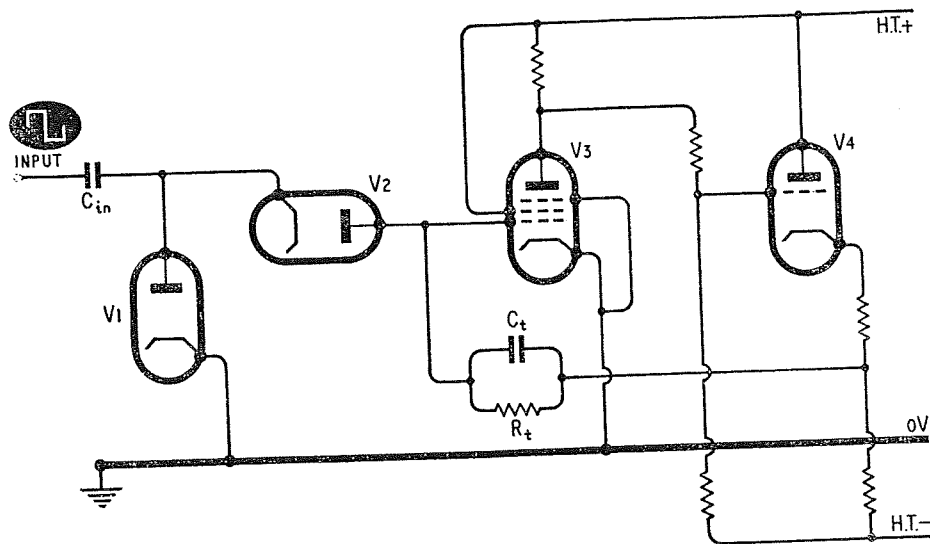

Fig. 9.4 A basic ratemeter circuit with feedback

9.2.2 Accurate Ratemeter

The circuit of a linear ratemeter which can provide an accuracy of better than $\pm 1\%$ of the full scale deflection was published in 1951⁽⁹⁾. This uses a diode pump circuit, but as shown in the basic circuit of Fig. 9.4, the tank capacitor, C_t , is connected across a direct coupled amplifier. The pulses charge C_t as in the simple diode pump circuit of Fig. 9.2, but the feedback ensures that almost all of the resulting change in potential across C_t appears at the side remote from V_2 , since the feedback amplifier circuit of V_3 and V_4 maintains the potential of the grid of V_3 almost constant. The grid of V_3 is a 'virtual earth'. The change in potential across C_t divided by the change in potential of the grid of V_3 is equal to the gain of the amplifier circuit; this gain is normally over 100. Thus the voltage across C_t has little effect on the charge per input pulse fed to C_t . Equation (3) for the diode pump circuit becomes

$$V_e = nR_t \left(V_{in} - \frac{V_e}{G} \right) C_{in} \quad (5)$$

where G is the gain of the amplifier. V_e/G can be made considerably less than 1% of V_{in} and therefore can be neglected. This basic feedback principle is used in many modern ratemeter circuits.

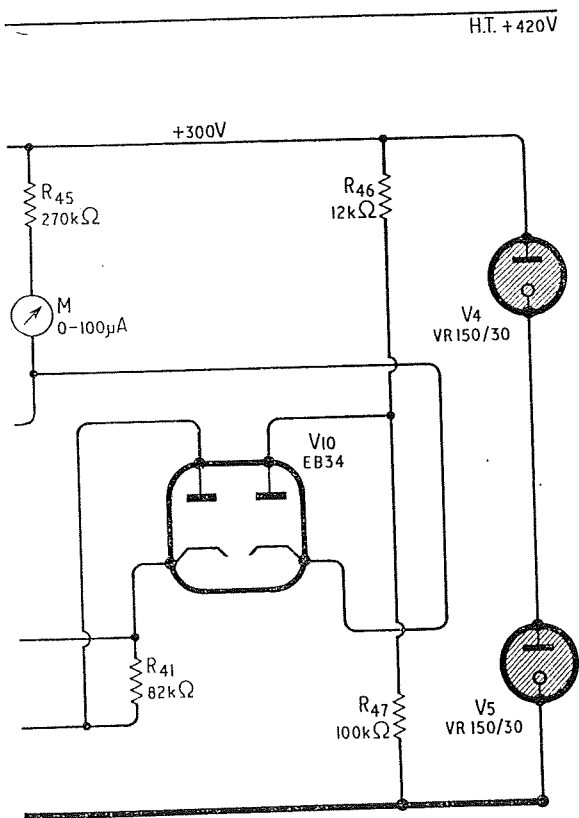

the 1021C monitor (somewhat simplified).

ELECTRONIC COUNTING CIRCUITS

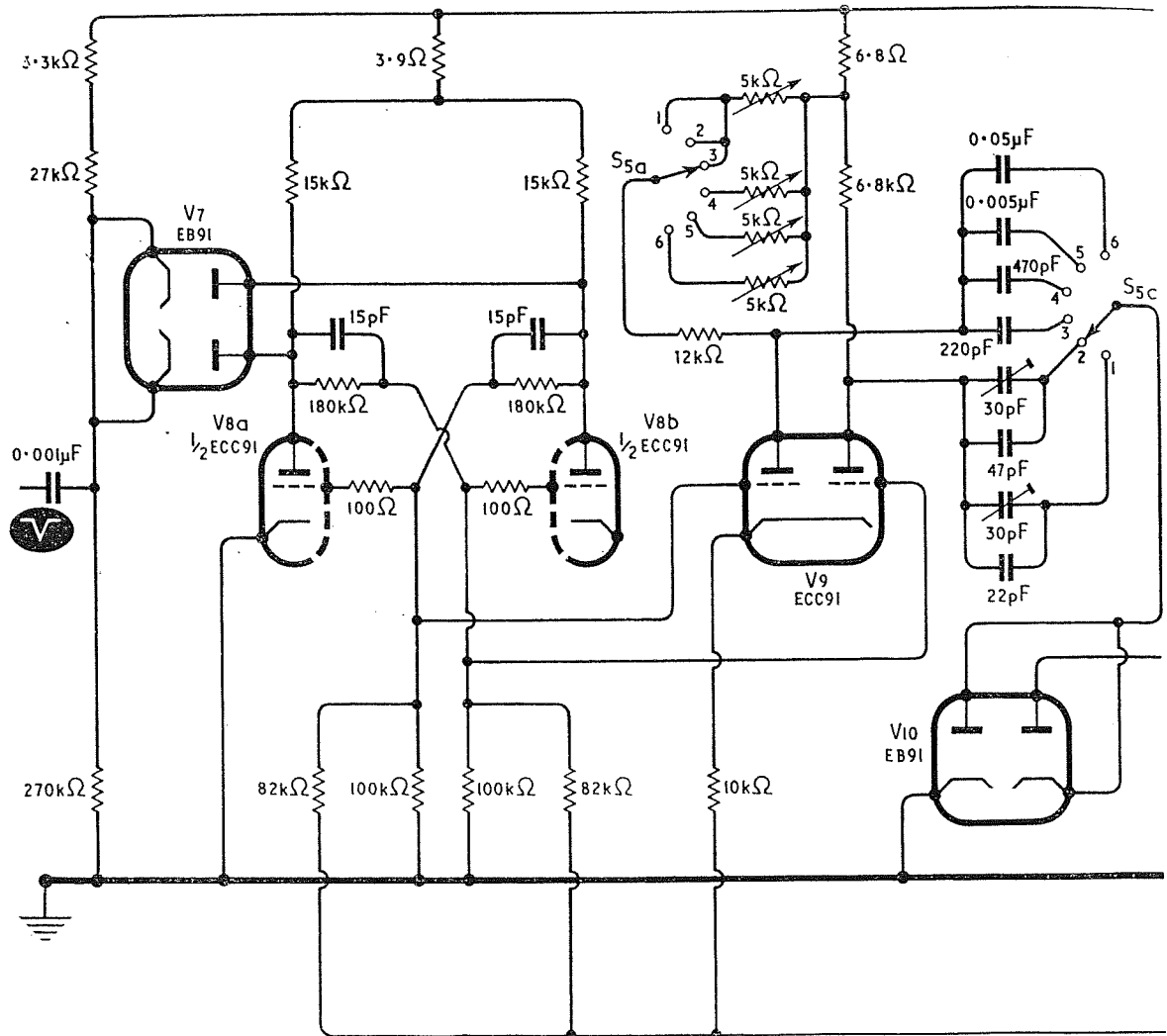
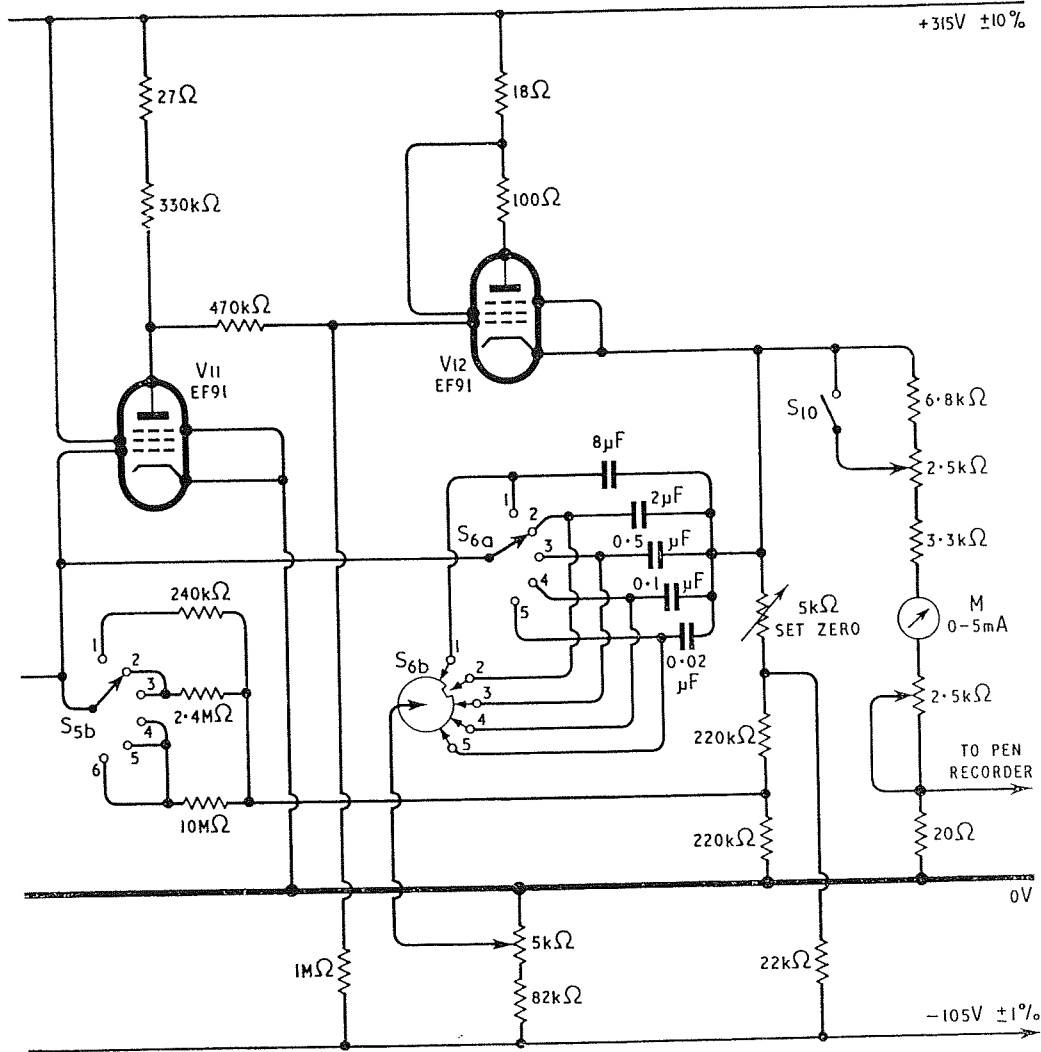

Fig. 9.5 An accurate

A practical circuit of a ratemeter employing the principles of Fig. 9.4 is shown in Fig. 9.5⁽⁹⁾. S_5 is the range switch and S_6 can be used to adjust the time constant. The tank circuit capacitors which are not in use at any time are connected via S_{6b} to a 5 kΩ potentiometer, the sliding contact of which is adjusted to the mean potential of the grid of V_{11} (which is almost constant for the reasons discussed above). When S_6 is operated to bring another capacitor into circuit, this capacitor already has almost the correct charge and therefore one does not have to wait very long for the desired equilibrium reading to be obtained.

The diodes V_7 gate the incoming pulses alternately to the anodes of the bistable circuit of V_8 . The square wave from V_8 is fed to V_9 , the two halves of which conduct alternately and limit the amplitude of the square wave to a value determined by the anode load resistors and the cathode resistor. The current passing through the conducting section of V_9 is accurately determined, since the grid of the conducting section of V_9 is held at earth potential by the conducting section of V_8 . The output pulses from V_9 are fed to the input capacitor of the diode pump selected by S_{5c} , the range switch. If the input capacitor is small, the charge fed to the diode pump



ratemeter circuit

per input pulse will be small and a high frequency input will be required for a full scale deflection. The value of the integrating circuit resistor is reduced on the high frequency ranges or the input capacitor would have to be extremely small and changes in the stray wiring capacitance could produce errors; the integrating circuit resistors are selected by S_{5b} . The full scale readings of each range can be set by adjusting the preset potentiometers selected by S_{5a} except for the two upper frequency ranges which are adjusted for the correct full scale deflection by the preset trimmers in the diode pump input capacitance. If the values shown in Fig. 9.5

are employed, full scale readings from 1 to 100,000 pulses per second are obtained increasing from range to range by factors of ten. Intermediate ranges are also very desirable.

It is most important that the diode input capacitors in the S_{5c} circuit should be of high stability, since any change in their value will affect the meter deflection. The wiring associated with these capacitors should be kept short and rigid so that no changes of stray capacity are likely to occur. The tank capacitors selected by S_{6a} must have a very high leakage resistance, although their stability is not so important. The voltage built up across them

at full scale deflection is about 70 V on ranges 1 and 2 and about 150 V on the other ranges. Variations in the potential of the grid of V11 are normally less than 1 V.

9.2.3 Ratemeter with Auto-correction for Lost Counts

A ratemeter has been constructed which will automatically compensate for counts that are lost due to the finite resolving time of the system⁽¹²⁾. It incorporates the feedback principle used in the circuit of Fig. 9.4 together with another feedback loop. The use of such a ratemeter enables the time normally taken in correcting for resolving time losses to be saved. It has been shown in Chapter 1 that if n pulses per second are recorded by a system of resolving time t , then the number of pulses, N , which would have been recorded if the resolving

time of the system had been zero is given by the equation

$$N = \frac{n}{(1-nt)}$$

In the ratemeter circuit to be described, feedback is used so that a rising non-linear characteristic is obtained which provides an output of $1/(1-nt)$ times the output which would be obtained without feedback. The feedback must make the system more and more sensitive as the input pulse rate increases. This system can be used to compensate for counts lost in the ratemeter circuit itself or in another part of the apparatus preceding the ratemeter provided that the resolving time of the system is known.

In the case of the linear ratemeter of Fig. 9.5 it has been shown from equation (5) that

$$V_e = nR_i V_{in} C_{in}$$

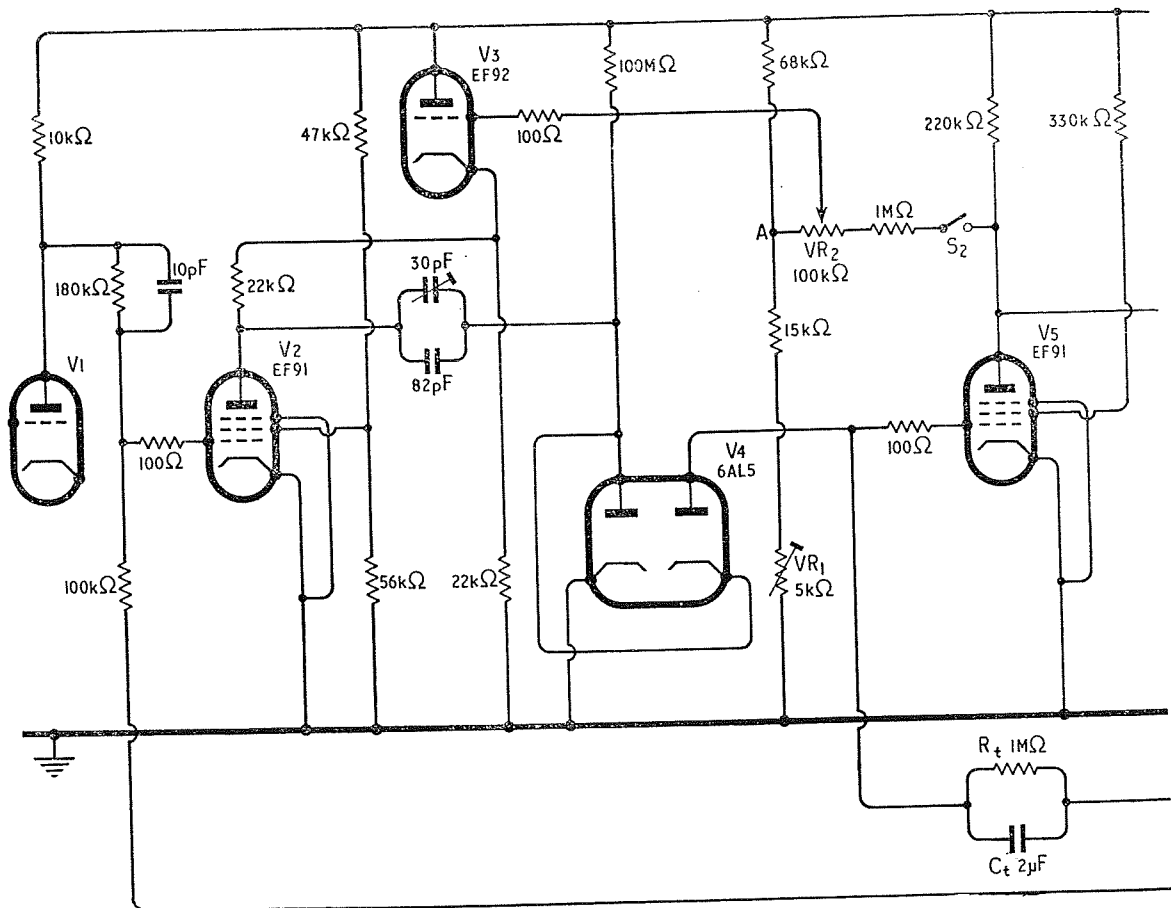

Fig. 9.6 A counting rate meter with automatic compensa-

if G is large. If a fraction p of the voltage V_e is fed back so that it adds to the input, the following equation applies

$$V_e = (V_{in} + pV_e)C_{in}R_t n$$

or

$$V_e = V_{in}C_{in}R_t \frac{n}{(1 - npC_{in}R_t)}$$

Hence if p is chosen so that $pC_{in}R_t$ is equal to the resolving time t of the equipment,

$$V_e = V_{in}C_{in}R_t \frac{n}{(1 - nt)} = V_{in}C_{in}R_t N$$

Thus the output voltage is directly proportional to the corrected counting rate, N .

A circuit of this type with a full scale deflection of 10,000 pulses per second for use when the system

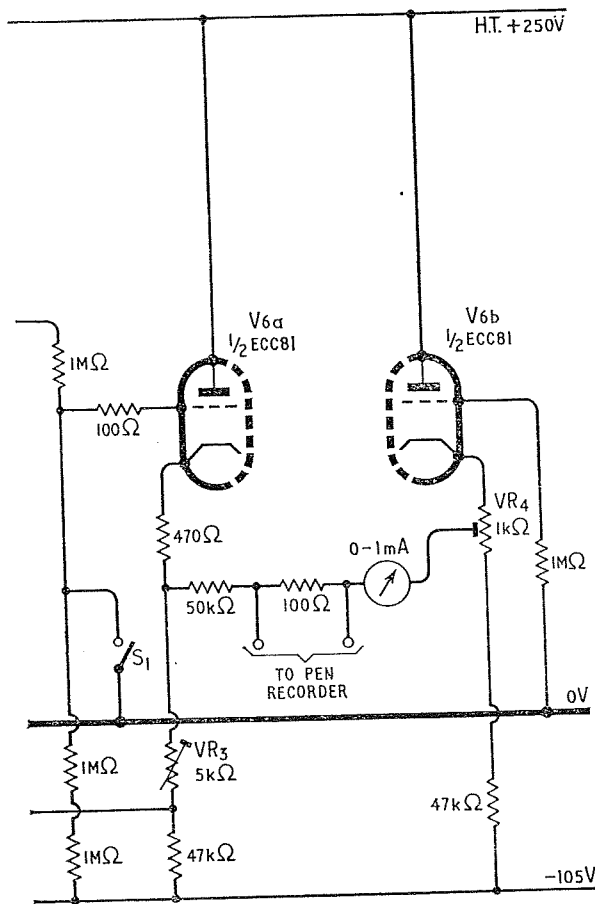

tion for counts lost due to the finite resolving time.

has a resolving time of about 10 μ sec is shown in Fig. 9.6⁽¹²⁾. It is very suitable for use with scintillation or proportional counters. If S_2 is opened, the extra feedback loop from the anode of $V5$ to the grid of $V3$ is broken and there will no longer be any compensation for lost counts.

The rectangular input pulses from $V1$ alternately cut off and saturate $V2$. When saturated the anode potential of $V2$ is only a few volts above earth potential. The anode voltage of $V2$ thus swings between this lower limit and an upper limit determined by the cathode potential of $V3$ which is a few volts above the grid potential of $V3$. The peak to peak anode voltage swing of $V2$ is thus approximately equal to the potential of the grid of $V3$ above earth.

The anode potential of $V5$ increases with increasing input frequency and the grid of $V3$ receives a portion of this increase when S_2 is closed. The anode voltage swing of $V2$ therefore becomes larger with the result that the charge per input pulse fed to the diode pump circuit, $V4$, is increased, thus giving the desired rising characteristic with increasing frequency.

A few adjustments must be made before the instrument is used. S_1 is closed and VR_4 adjusted for a zero reading of the meter. S_1 is then opened and VR_3 is adjusted for a zero reading. The grid of $V6a$ is then at earth potential and, owing to the values of the coupling resistors and the negative supply line voltage, the anode of $V5$ will be at +52.5 V. A sensitive high resistance voltmeter should then be connected from the anode of $V5$ to the point marked A , and VR_1 adjusted for a zero reading on this meter. Both of these points and the grid of $V3$ are now at +52.5 V and the peak to peak amplitude of the pulses fed to the diode pump will also be 52.5 V. This adjustment is made so that the pulse amplitude is unaffected by the setting of VR_2 at low input pulse frequencies. Evenly spaced pulses are now fed to the circuit with S_2 open and the input trimmer capacitor in the anode circuit of $V2$ is adjusted so that the meter indicates the input frequency. S_2 is then closed and VR_2 of is adjusted until the desired amount of compensation is obtained. For example, if the resolving time of the system is 10 μ sec, the pulse generator may be set to provide

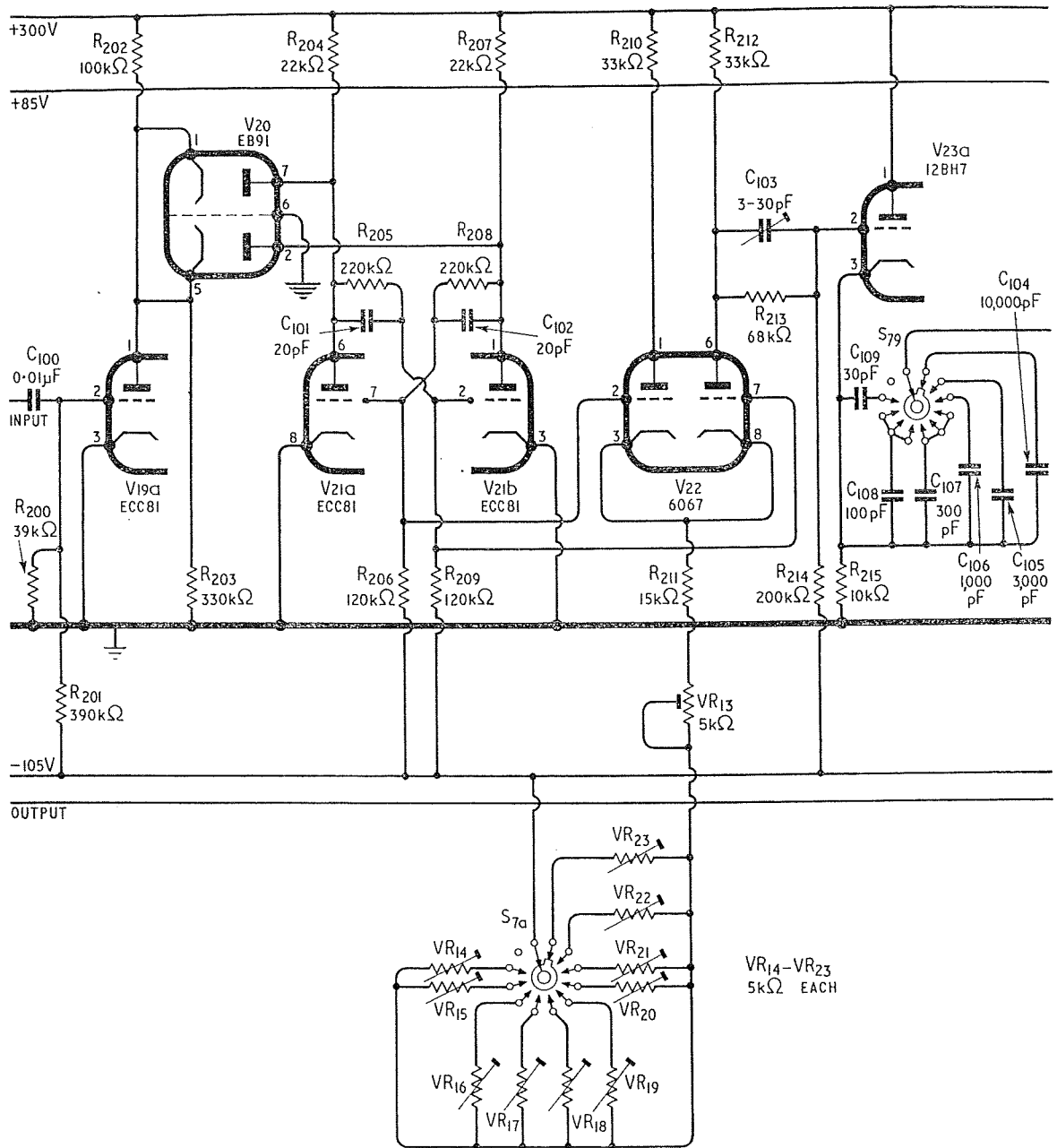

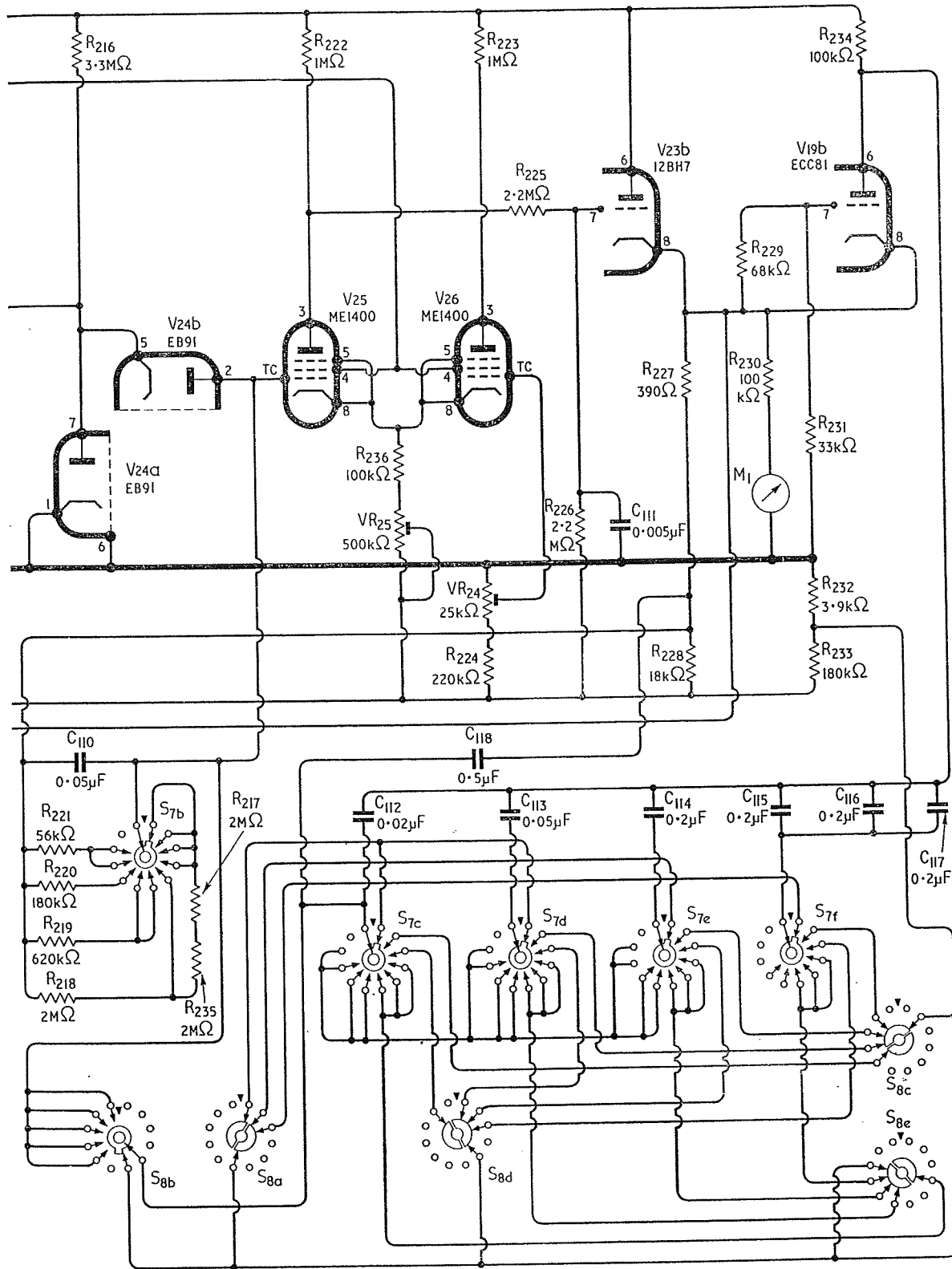

Fig. 9.7 A ratemeter with automatic control of the time constant (part of the Ecko N600 ratemeter).

$n = 9,100$ evenly spaced pulses per second and VR_2 should be adjusted until the meter reads $N = 10,000$ pulses per second. The meter should now indicate the compensated count rate at all points on the scale. If at any time the instrument is to be used to count evenly spaced pulses, no compensation will be required and S_2 should therefore be opened. The instrument is accurate to about 1% of the full scale deflection.

9.2.4 Ratemeter with Automatic Control of Time Constant

The Ecko type N600 ratemeter⁽¹³⁾ employs a circuit in which the time constant is automatically adjusted to provide an almost constant pre-selected mean probable statistical error. On the six lowest frequency ranges with full scale deflections of 3 to 1,000 pulses per second, the mean probable error may be set at 1%, 2%, 3%, 5% or 10%. A sixth position of the mean probable error switch enables a short time constant to be obtained during the manual scanning of energy peaks, etc. On the ranges with full scale deflections of 3,000 and 10,000 pulses per second the mean probable error is fixed at 1%, whilst the two highest frequency ranges with full scale deflections of 30,000 and 100,000 pulses per second are intended mainly for the measurement of evenly spaced pulses, since the minimum resolving time of three microseconds will lead to mean counting losses of 10% and 30% at full scale deflection in these respective ranges if the input pulses are randomly distributed in time. In addition to the mean probable error control, a number of other refinements are incorporated into this ratemeter and will be described below.

The circuit of the rate measuring section of the N600 ratemeter is shown in Fig. 9.7⁽¹³⁾. The positive going pulses from the preceding pulse height analyser circuit are fed into the amplifier $V19a$. The negative going output pulses from this stage are alternately gated by $V20$ to the two valves $V21a$ and $V21b$ which form a bistable circuit. The outputs from this stage are fed into the $V22$ limiter stage. Each section of $V22$ is alternately cut off. The conducting section passes a current which is determined by the anode load resistor, the cathode resis-

tors and the negative supply line potential. The full scale deflection of each range can be adjusted by the appropriate preset resistor which is switched into circuit by the range switch S_{7a} . VR_{13} is a master sensitivity control which is effective on all ranges. These sensitivity controls alter the amplitude of the square wave which is fed from $V22$ to the cathode follower stage of $V23a$. This cathode follower is included because it can provide the large current pulses which are necessary to fully charge the diode pump input capacitor (selected by S_{7g}) in the shortest possible time.

The two diodes $V24$ form the diode pump circuit. $V24a$ is normally in the conducting state owing to the current passing through it from the H.T. line via R_{21g} , whilst $V24b$ is normally in the non-conducting state owing to the slightly negative potential applied to its anode from the cathode circuit of $V23b$.

$V25$ and $V26$ are used in a high gain differential amplifier which compensates for any changes in the heater supply voltage. The output from $V25$ is fed via a potential divider to the grid of the cathode follower $V23b$ which is at about earth potential. The output from this valve is fed back to the grid of $V25$ via the integrating resistors associated with S_{7b} . This feedback circuit is very similar in principle to that of Fig. 9.4 and therefore the grid of $V25$ remains at an almost constant potential. VR_{24} controls the grid voltage of $V26$ and hence the common cathode potential; it therefore affects the anode potential of $V25$ and can be used as the set zero control.

A small capacitor, C_{110} , is permanently in circuit and acts as the integrating capacitor when the shortest time constant is being used (that is, when S_{8b} is open circuited). The remaining integrating capacitors, C_{112} to C_{117} , are selected singly or in groups by the range switch S_7 and the mean probable error switch, S_8 . Except for C_{110} , the integrating capacitors are effectively connected across the resistor(s) selected by S_{7b} via the Miller integrating valve $V19b$. The value of the capacitor(s) selected by the switches is effectively multiplied by the gain of the valve $V19b$, but the leakage current passed by the capacitors is effectively multiplied by the same factor also. Capacitors of a reasonably small value

can, therefore, be used, but they must have a very high insulation resistance.

The input voltage applied to $V19b$ from the cathode of $V23b$ develops a large potential across the anode resistor of $V19b$. This charges the integrating capacitor(s) selected by the switches, the other side of the capacitor(s) being held at the almost constant potential of the grid of $V25$. The charge held by a capacitor is equal to the voltage across it multiplied by its capacitance value. Increasing the voltage applied to the integrating capacitor(s) by the use of the amplifier stage of $V19b$ therefore has the same effect on the charge stored as an increase in the capacitance value. The capacitors not in use are kept charged to about the same potential as the capacitor(s) being used by the same method as that employed in the circuit of Fig. 9.5. No large change in the meter deflection will, therefore, occur in this case if the mean probable error switch is altered.

It has been mentioned earlier in this chapter that the fractional standard deviation of a single ratemeter reading is $1/\sqrt{2nR_iC_i}$, and the fractional mean probable error is this quantity multiplied by 0.675. The percentage mean probable error will thus remain constant as n varies if the product nR_iC_i remains constant. That is, the time constant must vary inversely as the count rate. The grid resistors of $V19b$ provide a bias to the Miller integrator valve which renders the gain of the stage non-linear. The gain decreases by a factor of three as the count rate increases from about 1/3 of the full scale deflection to full scale. The mean probable error is thus kept fairly constant over this part of each range.

The temperature coefficient of the diode pump input capacitors selected by S_{7g} is opposite in sign to the temperature coefficient of the integrating resistors selected by S_{7b} and this, therefore, assists in maintaining stability with changes of temperature.

9.2.5 Logarithmic Ratemeter

A logarithmic ratemeter is one which provides an output or a meter reading which is proportional to the logarithm of the input frequency. This type of ratemeter can measure a very wide range of pulse

frequencies without range switching. This is obviously very convenient if automatic equipment or a pen recorder is to be operated from the output of the ratemeter. There are many applications of logarithmic ratemeters both in radio-isotope work and in other fields. For example, if a radio-isotope of short half life is placed near a probe unit which feeds a logarithmic ratemeter and the output from the latter is passed to a pen recorder, a straight line graph will be obtained. Similarly, if a logarithmic ratemeter is used in the measurement of the thickness of a material by the absorption of beta or gamma radiation, the reading obtained will be linearly related to the thickness of the material if the absorption is exponential. Logarithmic ratemeters are also useful when the ratio of two counting rates is required, since the difference in the output currents or voltages of two logarithmic ratemeters is proportional to the logarithm of the ratio of the input pulse rates.

The percentage accuracy of logarithmic ratemeters is normally fairly constant over a very wide range of input frequencies. The percentage accuracy of a linear ratemeter at full scale deflection is considerably greater than that of a logarithmic ratemeter of similar quality, but in the case of a linear ratemeter, however, the percentage accuracy decreases on any range as the input frequency decreases.

It has been shown⁽¹⁴⁾ that the output of a number of diode pump circuits of differing time constants may be added to give a response which is almost logarithmic over a very wide frequency range. Each of the diode pump circuits is non-linear, the output from each pump circuit being determined by equation (4), since the voltage across the tank circuit is not kept small. If the time constant of a diode pump circuit is T , the output voltage from a single pump circuit is

$$V_e = V_{in} \frac{nT}{(1+nT)}$$

If nT is much smaller than unity, V_e is approximately zero, whilst if nT is much larger than unity, V_e will be approximately equal to V_{in} . When m diode pump circuits of time constants T_1, T_2, T_3 , etc. are employed, the sum of the output voltages,

ELECTRONIC COUNTING CIRCUITS

V_e , will be given by

$$V_e = V_{in} \left(\frac{nT_1}{1+nT_1} + \frac{nT_2}{1+nT_2} + \frac{nT_3}{1+nT_3} + \dots + \frac{nT_m}{1+nT_m} \right) \quad (6)$$

If $T_2 = 0.1 T_1$ and $T_3 = 0.1 T_2$, etc., at any given frequency between $1/T_2$ and $1/T_{m-1}$ a number of

terms in the bracket of equation (6) will be approximately zero, some will be between zero and unity and the remainder will be approximately unity. If n is increased by a factor of ten, there will be an additional term of unity and one less zero term, whilst the values of the intermediate terms will be unchanged, although they will have moved one position to the right. Each factor of ten increase in

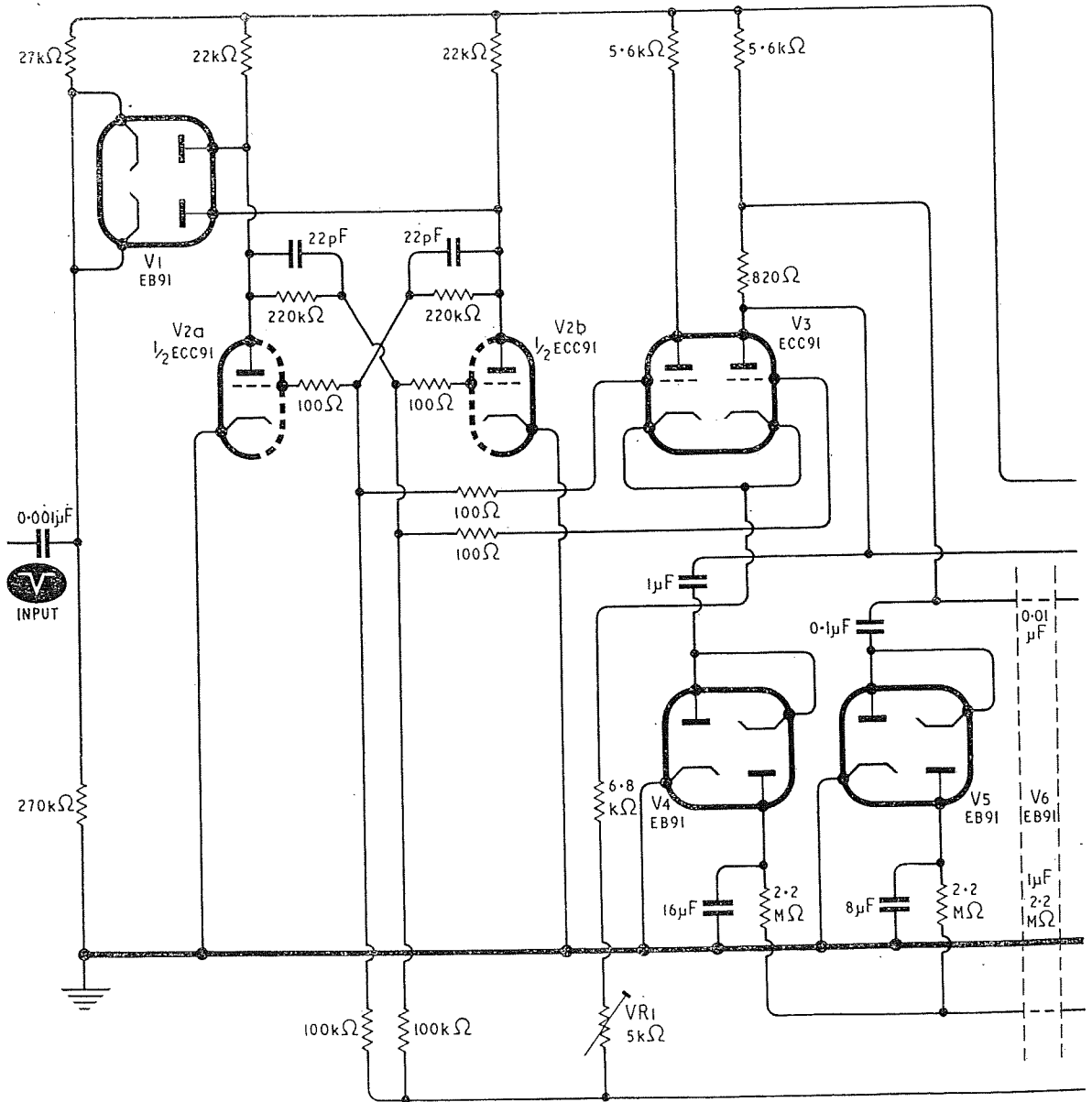

Fig. 9.8 A wide range

the input frequency, therefore, causes the same increase in the output voltage and the response from decade to decade is logarithmic. It has been shown empirically that the response is also closely logarithmic over a fraction of a decade⁽¹⁴⁾. It can be shown mathematically that the output voltage is approximately proportional to the logarithm of the input pulse frequency⁽¹⁵⁾.

If a ratemeter is to cover N decades and not deviate from a logarithmic response by more than $\pm 3\%$, $(N+3)$ diode pump circuits are needed⁽¹⁴⁾. This requirement may be reduced somewhat if the input pulse amplitude to the two end diode pump circuits which have the largest and smallest time constants is increased somewhat, since this reduces the errors caused by the fact that the number of decades is limited. If the amplitude of the pulses fed to these two end pump circuits is increased by 18%, the deviation from a logarithmic response is less than 3% for input frequencies between $1/T_{\max}$ and $1/T_{\min}$. The factor by which the time constants increase from one pump circuit to the next is normally ten; other factors may be used, but the capacitors required will not then all be of the preferred values.

A logarithmic ratemeter circuit designed to cover

a range of 1 to 100,000 pulses per second with an accuracy of $\pm 10\%$ is shown in Fig. 9.8⁽¹⁴⁾. This circuit is in many ways similar to that of Fig. 9.5. The input pulses to be counted are applied to the bistable circuit of $V2$ via the gating diodes $V1$. $V3$ is a limiter valve, each section of which conducts alternately.

The diode pumps $V5$, $V6$, $V7$ and $V8$ are fed with a 50 V square wave, but $V4$ and $V9$ receive a square wave of 15% larger amplitude from the anode of $V3b$. It is more convenient to add the currents passing through the leakage resistors than to add the output voltages. The output currents from the diode pump circuits operate the circuit of $V10$ and $V11$ which feed the meter M . This meter must show a zero deflection at a small but finite input pulse rate corresponding to the bottom of the range of the instrument. The current from the diode pumps is therefore returned to VR_2 which can be used to adjust the zero. The full scale deflection of the instrument can be adjusted by means of VR_1 which controls the amplitude of the square waves fed to the diode pump.

The leakage resistors of $V8$ and $V9$ ($2.0\text{ M}\Omega$) are 10% smaller than the leakage resistors of the other

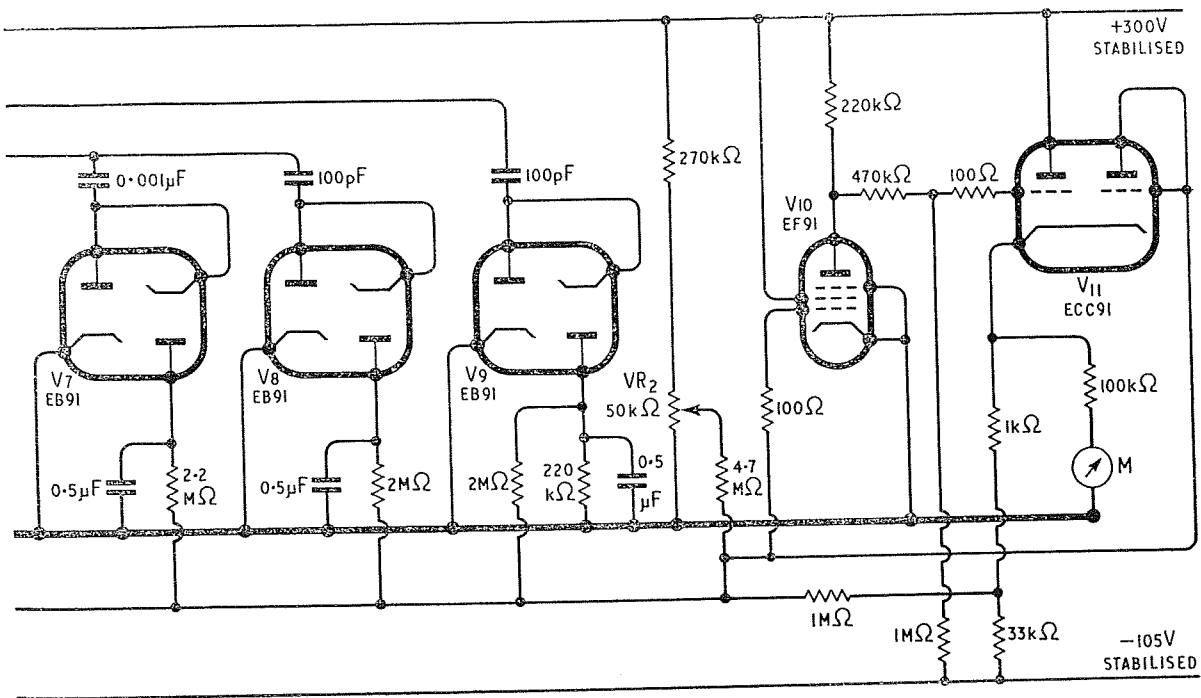

logarithmic ratemeter

ELECTRONIC COUNTING CIRCUITS

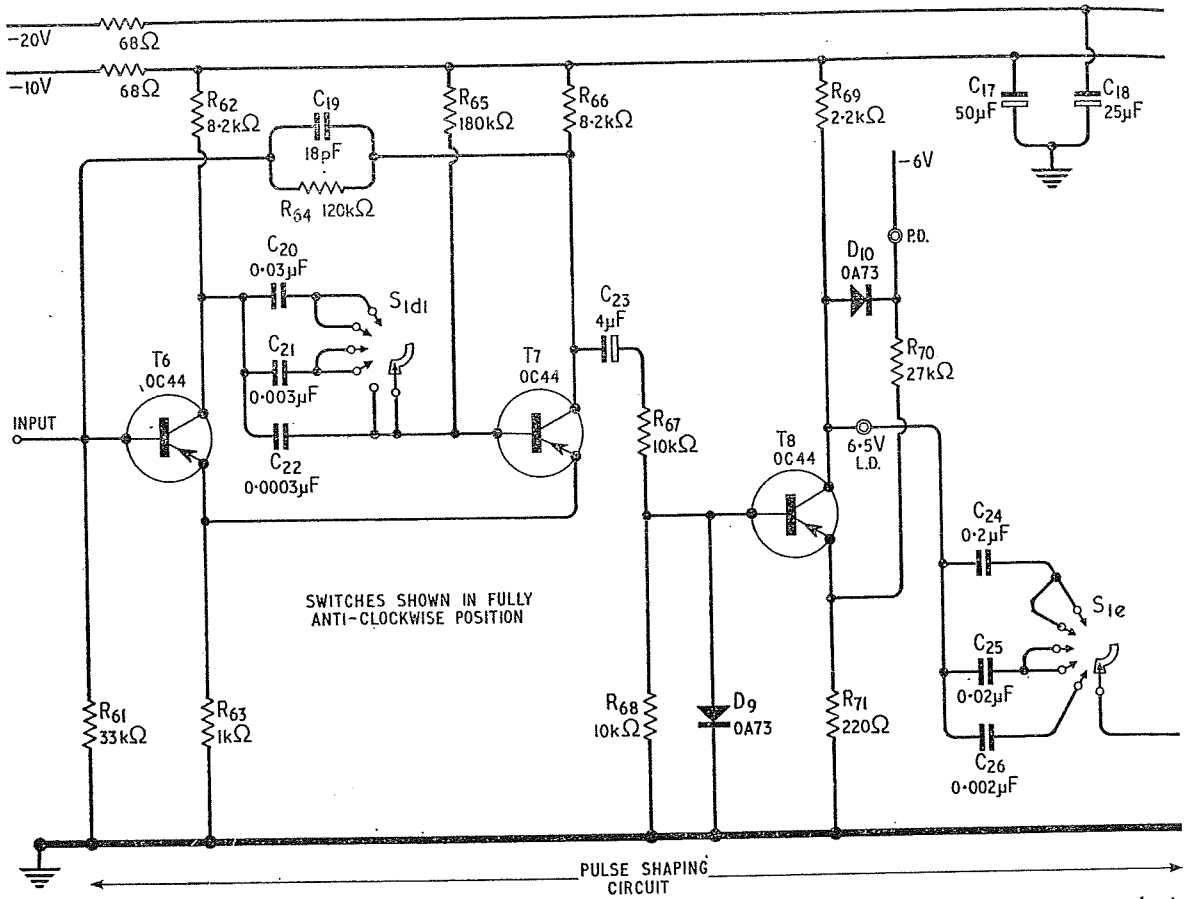

Fig. 9.9 A transistor ratemeter employing

diode pump circuits to compensate for the estimated 10 pF stray capacitance in the input circuits of these two diodes, since this forms an appreciable fraction of the 100 pF input capacitors to the two diode pump circuits. In the other diode circuits the input capacitance is larger and any additional stray capacitance can be neglected. The leakage resistor of $V9$ is bypassed to earth by a resistor of 1/10 of its value in order that the diode pump input capacitor may be ten times as large as would otherwise be possible. If the input capacitor to this stage were only 10 pF, considerable error would be likely to arise owing to additional stray capacity.

9.2.6 Transistor Ratemeter

The rate measuring circuit of the Ecko N645A portable transistor ratemeter is shown in Fig.9.9(16).

The range switch, S_1 , also selects the time constant as shown below.

Position of S_1	1	2	3	4	5	6
Full scale deflection (Pulses per second)	OFF	1,000	100	100	10	10
Time constant (sec)	OFF	4	8	4	4	20

The instrument has an accuracy of $\pm 5\%$ of the full scale deflection and can be used with suitable scintillation probes for the detection of alpha or gamma radiation or with a Geiger probe for the detection of beta particles.

The circuit is basically similar to the valve ratemeter circuits which have already been described. After amplification the input pulses from the probe are applied to the base of $T6$ which forms a bistable circuit with $T7$. The output pulses from $T7$ have a

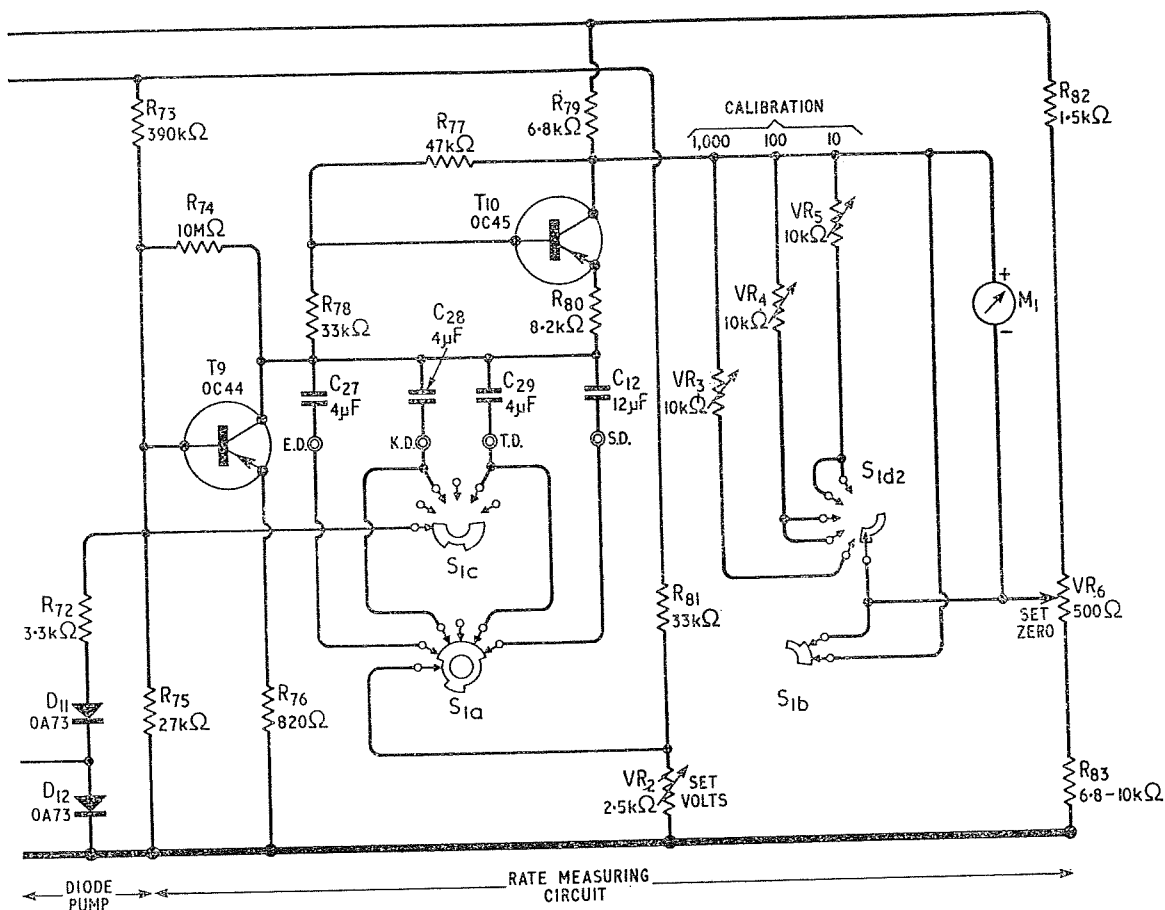

a diode pump circuit

pre-set amplitude and duration. The catching diode in the collector circuit of T8 limits the output pulse amplitude from this stage to 6 V. These pulses are fed to the diode pump input capacitor which is selected by S_{1e} ; the capacitor chosen determines the range.

The output current from the diode pump circuit is applied to the d.c amplifier T9 and T10. The integrating capacitors connected between the collector and base of T9 are selected by S_{1c} . The capacitors not being used at any time are charged to approximately the voltage of the used capacitor by means of S_{1a} so that transients are minimised when they are switched into the circuit. The collector of T10 feeds the meter M_1 , the ranges being adjusted for the correct full scale deflection by means of the three preset resistors in the collector circuit of T10. When the instrument is switched off, the meter is

short circuited by means of S_{1b} to protect its movement.

9.2.7 Rate of Revolution Indicators

It is often useful to be able to display the rate of revolution of a shaft as the deflection of a meter. This can be done accurately by arranging that a pair of contacts connected in series with a resistor and a battery close once per revolution of the shaft; the voltage pulses across the contacts are fed into a linear or logarithmic ratemeter such as those described previously. A suitable photocell pick up could also be used if suitable arrangements are made to allow a beam of light to fall on the photocell once per revolution of the shaft.

The simple revolution counter of Fig. 9.10⁽¹⁷⁾ is included as a complete contrast to the more

ELECTRONIC COUNTING CIRCUITS

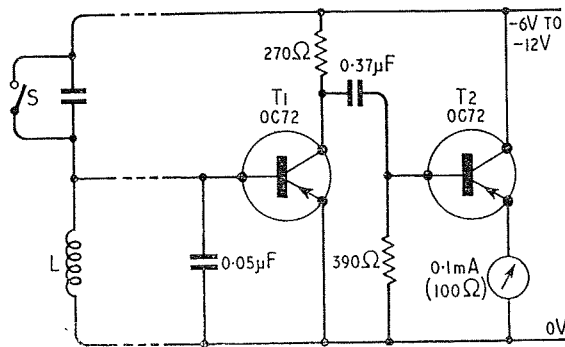

Fig. 9.10 A simple rate of revolution indicator

complicated ratemeter circuits. It is especially suitable for use as an engine speed indicator for petrol engines, but can be used to measure the rate of rotation of any shaft if a pair of contacts operated by the shaft are fitted. The coil L may be the ignition coil of a petrol engine and S the contacts of the contact breaker. The contacts of a petrol engine do not open once per revolution, but the meter can be calibrated accordingly.

Each time the contacts are opened, a voltage pulse is produced across the coil L . This is applied to the base of $T1$ and produces a current of rectangular waveform in the collector circuit of this transistor. The coupling circuit between the two transistors differentiates the pulses and the negative

going part of the differentiated waveform causes $T2$ to conduct. If the time constant of the differentiating circuit is low enough, the meter reading will be almost proportional to the input pulse rate and therefore to the rate of revolution of the shaft. It is desirable, however, that the revolution indicator shall be calibrated at various points on the curve, since the meter reading is not usually quite linear with respect to counting rate.

9.2.8 Other Types of Ratemeter

Many other type of ratemeter for use at relatively low frequencies (less than 1 Mc/s) have been designed. For example, a logic circuit may be included in a ratemeter in order to provide a means of changing the range automatically⁽¹⁸⁾. The accurate measurement of high frequencies may be rapidly carried out by high speed counting circuits as described in Chapter 12. Another type of instrument for the measurement of high frequencies employs a stable beat frequency oscillator; beats which occur between this oscillator frequency and the input signal are amplified and fed into a normal type of ratemeter⁽¹⁹⁾. Frequency meters of this type are much simpler than those instruments which employ high speed counting circuits, but they are not usually so convenient to use.

REFERENCES

1. A. G. BOUSQUET, 'Counting rate meters versus scalars', *Nucleonics*, **4**, 2, 61 (1949).
2. G. D. SMITH, 'Counting-rate meters', *Electron. Eng.*, **24**, 14 (1952).
3. E. LORENZ, J. WEIKEL & S. G. NORTEN, 'A counting-rate and frequency meter'. *Rev. Sci. Instr.*, **17**, 276 (1946).
4. E. FRANKLIN & W. R. LOOSEMORE., 'A survey equipment using low-voltage halogen-quenched Geiger-Müller counters', *Proc. Inst. Elec. Engr. II*, **98**, 237 (1951).
5. D. H. PEIRSON, 'Some Cold Cathode Valve Circuits used in the Measurement of Radioactivity'. A.E.R.E. Report EL/R 1204 (1953).
6. H. L. SCHULTZ, 'Frequency meter for random or uniformly spaced pulses', *Rev. Sci. Instr.*, **18**, 223 (1947).
7. 'Instruction Manual for Monitor, Radiation, Portable type' 1021C and 1021B' Specifications and Manuals Section, A.E.R.E., Harwell.
8. A. KIP, A. BOUSQUET, R. EVANS & W. TUTTLE, 'The design and operation of an improved counting-rate meter'. *Rev. Sci. Instr.*, **17**, 323 (1946).
9. E. H. COOKE-YARBOROUGH & E. W. PULSFORD, 'A counting-rate meter of high accuracy', *Proc. Inst. Elec. Engr. II*, **98**, 191 (1951).
10. W. C. ELMORE. 'A counting-rate meter', *Nucleonics*, **2**, 4, 43 (1948).
11. D. TAYLOR, *The Measurement of Radioisotopes*, Methuen, 2nd Ed. (1957).
12. E. W. PULSFORD, 'A count-rate meter circuit having automatic correction for losses caused by finite resolving time'. A.E.R.E. Report EL/R 1326 (1954). Also *Electron. Eng.*, **26**, 356 (1954).
13. Ecko Ratemeter N600B. Technical Instructions.
14. E. H. COOKE-YARBOROUGH & E. W. PULSFORD, 'An accurate logarithmic counting-rate meter covering a wide range', *Proc. Inst. Elec. Engr., II*, **98**, 196 (1951).
15. J. HOWLETT Discussion on paper of reference 14, *Proc. Inst. Elec. Engr., II*, **98**, 205 (1951).
16. Ecko Field Ratemeter Type N645A. Technical Instructions.
17. D. J. W. SJOBBEMA, *Using Transistors*, 2nd. Ed. *Philips Technical Library*, (1961).
18. 'Pulse Rate Counter with Automatic Scale Change', Texas Instruments Application Note.
19. R. Q. LANE, 'A wide range analogue frequency meter' Fairchild Application Report AR-37.

10.1 INTRODUCTION

A counting circuit may provide information as to the state of the count by means of either a visual indication or by an electrical output. Any counting circuit which is not self indicating must provide electrical readout to the components which are used to convert this form of readout into visual readout, or information on the state of the count will not be available. In predetermined counting circuits the electrical readout can be used to operate any other circuit after a preset number of counts.

Although self indicating counting circuits are relatively simple, digital methods of readout are obviously much more satisfactory than analogue methods. It is very easy for a tired operator to make a mistake when adding the counts indicated by a binary neon or tungsten filament lamp display. A system employing ten separate lamps renders errors less likely, since the count in any decade is indicated by a single lamp and the operator does not have to carry out any addition. Even if ten lamps are employed in each decade and the number of counts indicated by each lamp is marked on the glass in front of the lamp, the display is still not ideal, since the position of the displayed digit varies with the count. Ideally a display should be of the 'In-line Digital' type in which the various digits are displayed in the same position and a multi-decade number appears as a line of digits. This type of readout not only occupies the minimum of space on the front panel of the instrument, but also reduces operating errors to a minimum. Other systems are used only for circuit simplicity.

Different types of counting circuit provide differ-

ent forms of electrical readout. In one form the output voltage or current increases step by step as the input pulses are applied; it is known as a staircase waveform. The EIT can provide this form of readout from the deflector plate which is not connected to the input. If the count in a decade is to be indicated by means of a meter, the electrical output must be in the form of a staircase waveform. Transistor binary decades can be arranged to provide this form of readout by one of the methods discussed in Chapter 8.

Other types of counting circuit (such as ring circuits, cold cathode decade selector tubes and trochotrons) provide electrical readout in the form of an output pulse at any one of ten different electrodes (decade readout). This form of readout is obviously very suitable for the operation of digital indicator tubes. It is normally much easier to convert decade readout into a staircase waveform than vice-versa.

The third type of electrical readout is the binary coded decimal system in which the count in each decade is given by a combination of the outputs from several binary stages. Variations of this coding occur when the 1st, 2nd, 3rd and 4th binary stages do not correspond to counts of 1, 2, 4 and 8 pulses respectively. It is relatively easy to convert these types of readout into either decade or staircase readout by the methods discussed in Chapter 8. Various other methods of information conversion are also available using beam switching tubes⁽¹⁾ or other devices.

Many methods by which readout can be effected from various types of counting circuit have already been fully discussed in previous chapters. The most

Table 10.1 FORMS OF READOUT COMMONLY EMPLOYED WITH VARIOUS TYPES OF COUNTING CIRCUIT

<i>Type of counter</i>	<i>Visual readout</i>	<i>Electrical readout</i>
Electro-magnetic	Normally self indicating digital. Relay switched electroluminescent digital etc.	Special contacts may provide electrical readout.
Trigger tube decade ring	Self indicating. Indicator tube.	Decade readout.
Trigger tube binary	Self indicating.	Binary readout.
Polycathode gas filled decade tubes	Self indicating. Indicator tube.	Decade readout from selector tubes only.
The E1T	Self indicating. (Meter readout possible).	Staircase waveform only available.
Beam switching Tubes	Indicator tubes. Ten filament or neon tubes. (Meter readout possible).	Decade readout.
Cascaded binary valve	One neon tube per binary. Meter readout.	Binary readout.
Cascaded binary valve with feedback to form decade system	Indicator tube. 4 or 10 neon tubes per decade. Meter.	Binary coded decade. (Various other codes are possible).
Transistor binary with feedback to form decade	Indicator tube (incl. Z550M). Meter. 4 or 10 filament or neon bulbs per decade.	Binary coded decade. (Various other codes possible).
PNPN four layer diode in a decade ring	Indicator tube. Ten neon or filament bulbs per decade. Meter possible.	Decade readout.
Tunnel diode	Meter. Other types after amplification of output.	Binary or staircase (depending on type of circuit).
Binary magnetic core	Magnetic is the simplest.	Decade possible.
Magnetic flux counters Ferro-electric counters	Any form of readout disturbs the counting process. (see Chapter 8)	
Ratemeter	Meter. Pen recorder.	Output voltage or current proportional to the input pulse rate or to some function of the input pulse rate.

common forms of readout are summarised in Table 10.1. In this chapter the detailed operation of gas filled cold cathode indicator tubes will be discussed and various other methods by which digital readout can be obtained will be mentioned. The principles employed in digital readout are often useful when other information than a pure number is to be displayed.

10.2 GAS FILLED COLD CATHODE INDICATOR TUBES

One of the most economical and popular forms of digital readout involves the use of one cold cathode numerical indicator tube per decade which displays an actual digit in the form of a red or orange glow. The Z550M is a special type of tube and will be discussed separately. Some manufacturers have registered trade names by which their numerical indicator tubes are known. These are:

<i>Manufacturer</i>	<i>Trade Name</i>
Burroughs	'Nixie'
Ericsson	'Digitron'
Hivac	'Numaticor'
S.T.C.	'Nodistron'

Another type of indicator tube is available which indicates a digit by means of the position of a point of light. The tube is mounted in an escutcheon on which the ten digits are marked. The digit to be indicated is the one which is adjacent to the point of light. The type of display and the construction of the tube are similar to that of the multi-electrode gas filled counting tubes described in Chapter 4 in which a point of light rotates during counting. This type of indicator tube will be referred to as a point indicator tube to distinguish it from numerical indicator tubes. Point indicator tubes are used mainly in high speed decades which are followed by gas filled decade tubes, since a similar form of readout is then available from all decades. They take a much smaller current than numerical indicator tubes owing to their smaller cathode area.

Some tubes for indicating characters other than digits are also available. The Ericsson GR2G (side viewing) and GR2H (end viewing) and a number of Burroughs tubes can indicate either a plus or a minus sign at any one time. The GR4G indicates $\frac{1}{4}$, $\frac{1}{2}$, $\frac{3}{4}$ or 1. The GR12G indicates one of the letters A to L inclusive, whilst the GR12H indicates one of the letters L to X excluding P and Q but with the addition of E. The Burroughs B5018 tube indicates A to K except I, whilst the B50113 indicates L to X excluding O, Q and U. It is not possible to place all 26 letters in one envelope and obtain satisfactory readout. The Mullard Z521M (ZM1021) indicates +, -, V, A, Ω, % or ~. The C.S.F. tube type F9007 indicates monetary signs of various countries including the £ sign, whilst the F9008 indicates some electrical symbols and the F9009 some mathematical symbols. The Burroughs B6037 tube indicates any number from 0 to 19. The B5094 indicates N, M or μ on the left hand side of the tube and S, V or A on the right hand side; this tube can therefore be employed to indicate the symbols for nanosecond (NS), millivolt (MV), microvolt (μV), etc.

The Burroughs cold cathode alpha numeric indicator tubes contain 13 or 15 cathodes and a common anode. Each cathode is in the form of a straight line. If a current passes to a number of suitably selected cathodes, the glow of these cathodes can be used to display any chosen digit or any letter of the alphabet. The alpha numeric display principle is used in electroluminescent display devices and is described in detail later in this chapter (Section 10.4).

The Burroughs Company also manufacture special cold cathode indicator tubes which may be used to obtain digital readout from circuits operating on biquinary principle. These tubes are similar to the normal cold cathode digital indicator tubes, but the odd numbered cathodes are placed in one section of the tube and the even numbered cathodes in another section. Each section has its own anode and the two sections are screened from each other. The cathodes 0 and 1, 2 and 3, 4 and 5, etc. are joined internally in pairs. The voltage applied to the anodes is controlled by the binary circuit and that applied to the cathodes by the ring of five of

Table 10.2 BASIC DETAILS OF NUMERICAL INDICATOR TUBES

	Num- eral height (in.)	Cathode Current (mA)	Min. anode volt- age	Nom. main- tain- ing volt- age	Typical operating conditions		Base	Remarks	End or side view- ing
					V_b	R_a (k Ω)			
<i>Burroughs:</i> 'Miniature' 7009	0.3	0.7-1.2	170	100	{300	200}	11 pin or flying lead	Low voltage tube	} End
B4081 (wide angle)	0.3	0.7-1.4	170	100	{250	150}			
7977 (B4032)*	0.3	0.7-1.4	170	140	250	91			
B4021	0.3	0.7-1.4	120	100	120	20			
'Standard' 6844A	0.6	1.5-3.0	170	140	{300	82}	B13B		
8037 (B5031)*	0.6	1.5-3.0	170	140	{250	56}			
B5092* (wide angle)	0.6	1.5-3.0	170	140					
'Super' 7153	0.8	2.0-3.0	250	140	{300	62}	B17A		
B6033*	0.8	1.5-4.0	170	140	{250	43}			
B6091* (wide angle)	0.8	1.5-4.0	170	140	{300	56}			
'Large' B8091* (wide angle)	1.375	3.0-6.0	170	140	{250	39}	B17A		
					{300	33}			
					{250	22}	B17A		
					{170	5.6}			
'Jumbo' B7094* (wide angle)	2.0	4.0-7.0	300	140	300	27	B17A		
'Rectangular' B5991*	0.61	1.5-3.0	170	140	{300	68}	SK136 special		
					{250	47}			
					{170	8.2}			
<i>C.S.F.:</i> TA542 (F9004)	0.81	2.2-3.6	170	140	250	40	B13A	} End Side	
TA543 (F9002)	2.25	10-14	170	140	250	10	DB25S special		
<i>Ericsson:</i> GR10G	1.181	9 max.	220	180	250	10	B26A	} Side End Side End Side Side	
GR10H	0.748	2.5 max.	150	140	250	82	B17A		
GR10J*	1.181	4 max.	150	145	250	33	B26A		
GR10K*	0.748	1.8 max.	150	140	250	82	B17A		
GR10M*	0.61	1.0-2.5	170	140	250	82	B13B		
GR10N	2.35	5	170	135	300	33	B17A		
GR10W	0.59	4 max.	220	160	220	18	Flying lead.		
<i>Hivac:</i> XN1	0.55	1.5-2.0	180	130	{180	33}	Flying lead	} Side	
					{250	82}			
					{300	120}			
<i>Mullard/Philips:</i> Z510M	0.61	1.5-3.0	160	127	250	68	B13B	} End End Side	
Z520M (ZM1020)*	0.61	1.0-2.5	170	140	250	56	B13B		
Z522M (ZM1040)*	1.2	3.0-6.0	170	140	250	27	B13B		
Z550M (ZM1050)	0.12	3		84	A.C. supply only		B13B	See text	End
ZM1080*	0.51	1.5-2.5	170	140	250	56	Flying lead	Red filter	Side
<i>S.T.C.:</i> GN4	0.6	1.5-3.0	170	140	250	56	B13B	} Red filter Red filter in GN5 only Red filter	} End End Side
GN5, GN5A	1.0	2.5-5.0	200	140	250	33	B12A		
GN6	0.6	1.5-2.5	170	140	300	100	Flying lead		

* Long life tube.

The Mullard ZM1022 is equivalent to the Z520M without the red filter.
Burroughs tubes with a suffix 'A' (e.g. 7009A) contain radio-active material to ensure prompt striking; they are useful when the tubes are to be photographed for data recording.

the biquinary. The appropriate digit is thus indicated.

The Burroughs 'Pixie' tube provides digital readout, but the ten small digits appear in different places near the circumference of the tube. It may be considered as a point indicator tube in which the discharge shines through a hole in the shape of the digit to be indicated. As in the case of point indicator tubes, the power consumed is very small. The display is similar to that of the Z550M tube which is described in Section 10.3.

any adjacent surfaces. The cathodes are surrounded by a wire mesh anode onto which most of the sputtered material will be deposited. If this type of anode were not used, the visibility of the glow would be reduced by the sputtered material which would be deposited on the glass envelope. Undesirable reflections would also occur from the back of the tube on which the sputtered material had been deposited.

Numerical indicator tubes provide an extremely clear form of readout which is much more satisfac-

Table 10.3 BASIC DETAILS OF POINT INDICATOR TUBES

Type	Cathode Current (mA)	Minimum supply voltage	Nominal maintaining voltage	Base	Escutcheon
GR10A (Ericsson)	0.05-0.25	129	108	B12A	N.80977
Z503M (Mullard/Philips)	0.05-0.25	129	108	B12A	101064

Cold cathode numerical indicator tubes consist of a number of cathodes (often made of nickel) mounted closely one behind the other inside an anode which consists of fine wire mesh. Each cathode is in the shape of one of the digits (or other symbols) which are to be indicated. At any one time a current is passed to only one of the cathodes which is covered in a red or orange glow. The cathode glow has a width which is considerably greater than that of the cathode itself and therefore the glow is not obscured by any other cathodes which may be in front of it. The cross section of the cathode wire may be about 0.4 mm in width by 0.25 mm in thickness, whereas the glow is about 3 mm in diameter⁽²⁾.

In a simple gas discharge tube there is a Crookes dark space between the negative glow and the cathode, but if an indicator tube is filled with a suitable gas at a suitable pressure, the Crookes dark space will not be visible. The anode is placed in the Faraday dark space so that the positive column striations are not present. A gas pressure is chosen which is low enough to give complete cathode coverage at a current of a few milliamps, but large enough to ensure a clear edge to each digit⁽³⁾.

During the operation of the tube a small amount of material will be sputtered from the cathode onto

tory than that given by self indicating counting tubes. When switching occurs the digits indicated appear almost exactly in the same position as the digits indicated previously. The tubes can be viewed from a wide angle and the brightness of the display is independent of the angle of view. Most types can be viewed from angles up to $\pm 50^\circ$ from the central axis, but wide angle types are also available which can be viewed from angles of up to $\pm 80^\circ$ from the axis⁽⁴⁾. The cathodes of these wide angle tubes are placed near to the tube face. Although numerical indicator tubes may extinguish completely at high counting speeds (above 200 kc/s), they impose no limitation on the counting speed, since they will indicate the correct count as soon as the counting speed falls or the counting ceases. The high speed counter must, however, be able to function satisfactorily with the variations in load imposed by a conducting or non-conducting indicator tube. Indicator tubes do require a high voltage supply, but the current passed is quite small.

The reliability of numerical indicator tubes is extremely good. Special long life versions of some tubes are available which contain a small amount of mercury vapour⁽²⁾. These tubes emit a faint bluish glow in addition to the cathode glow, but if used

ELECTRONIC COUNTING CIRCUITS

with a red filter they provide a display similar to that of the ordinary tubes. The mercury vapour reduces the current required to cover the cathode and also reduces sputtering. This gives an overall improvement of about twice the normal life. Some tubes are believed to have a life exceeding 200,000 hours⁽⁴⁾ and will therefore outlast the equipment in which they are used. The amount of sputtered material on the glass envelope gives an indication as to when the tube should be replaced.

A large variety of digital indicator tubes is available for displaying digits of various sizes. Tubes which display large digits are often constructed for side viewing, but for some applications tubes which are viewed through the domed end are more suitable. The side viewing tubes require less front to rear space, whereas the end viewing tubes take up a smaller height on the front panel and are very useful when several lines of indicator tubes must be stacked above one another.

Small numerical indicator tubes are quite suitable for most apparatus, since the operator is usually near to the equipment. If the state of the count must be visible from a distance, larger indicator tubes may be used and are ideal for use in industrial control panels. The approximate distances at which numerical indicator tubes can be read are as follows:

Height of numeral (in.)	0.3	0.6	1.5	2.25
Max. viewing distance (ft)	12	30	60	90

The tubes with large characters require more current than small tubes, but the striking and maintaining voltages are virtually independent of the size of the displayed digit.

10.2.1 Characteristics

The characteristic of a GR10G numerical indicator tube is shown in Fig. 10.1⁽⁵⁾. The shaded area shows the variation in maintaining voltage at various cathode currents owing to manufacturing tolerances

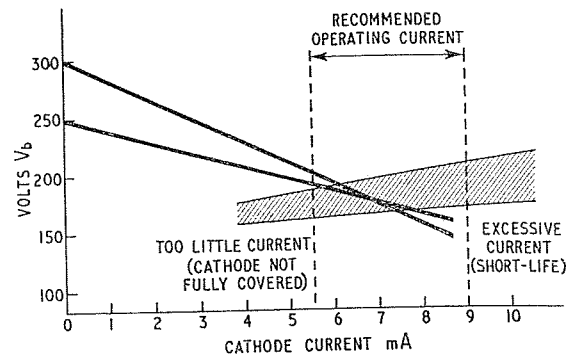

Fig. 10.1 The characteristic of a numerical indicator tube type GR10G

and tube ageing. It can be seen from the characteristic that the potential across the tube is not strongly dependent on the current passing through it. If the current is too small, the surface of the largest cathode will not be covered by the discharge, whilst if the current is too large, the life of the tube will be reduced. Owing to the sputtering of material from the cathodes during life, a used tube requires a higher current to completely cover the cathode than the minimum current required by a new tube. This is allowed for in the tube data sheets.

The basic circuit for the operation of numerical indicator tube is shown in Fig. 10.2. The current passing through the tube, i , is given by the equation

$$i = \frac{V_b - V_m}{R_a}$$

where V_b is the supply voltage.

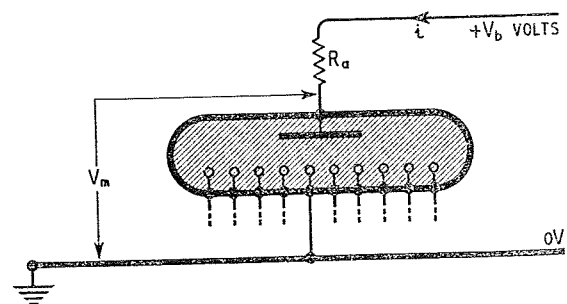

Fig. 10.2 The basic circuit for a numerical indicator tube showing only one cathode in circuit

V_m is the tube maintaining voltage which varies very slightly with i . Load lines for various values of R_a and V_b can be drawn on the characteristic of Fig. 10.1 in order to determine suitable values for these quantities. The load line should always intersect the characteristics of the tube within the recommended cathode current range as R_a and V_b vary within the expected tolerances. Two suitable load lines for different supply voltages are shown in Fig. 10.1. An additional requirement is that V_b must exceed the striking voltage of the tube. Generally it is good practice to employ a high value of V_b and a high value of R_a so that variations in V_b cause a relatively small change in the current passed by the tube.

In some cases it is advisable to include compensating resistors in the leads of those cathodes which have a smaller surface area than the other cathodes in the tube. For example, it is recommended that an 8.2 kΩ resistor is inserted into the cathode 1 lead of a GR10G tube and a 4.7 kΩ resistor in the cathode 7 lead. In some tubes, however, the design has been modified so that the use of additional compensating cathode resistors is unnecessary. In most plus and minus sign indicator tubes the series resistors are placed in the cathode leads. If the supply voltage is 250 V, the GR2G requires a 15 kΩ resistor in its +cathode lead and a 27 kΩ resistor in its -cathode lead, whilst the GR2H end viewing tube requires 82 kΩ and 120 kΩ resistors in these positions. The +sign has a larger cathode area and thus requires a smaller series resistor so that a larger current can flow.

The cathodes of a numerical indicator tube which are not being used at any time must either be unconnected or alternatively may be biased positively with respect to the conducting cathode. If the bias potential is not great enough, the unused cathodes will glow somewhat and the display will not be clear. The positive bias applied to the non-conducting cathodes is known as 'pre-bias'. The variation of the current passed by the non-conducting cathodes of a GR10H tube with the pre-bias voltages applied to them is shown in Fig. 10.3⁽⁶⁾. The current passed by an unused cathode decreases as its distance from the glowing cathode increases (owing to ionisation coupling). In the area A the unused

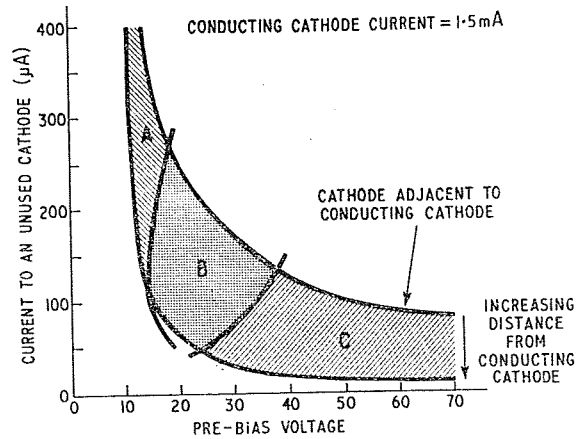

Fig. 10.3 Legibility of the numerical indicator tube type GR10H

cathodes are passing such a high current that the glow emitted by them completely obscures the desired glow from the conducting cathode. In the area B some confusion can arise, since it is only possible to distinguish the glowing cathode from the background haze with some difficulty. The operating point of all unused cathodes should normally be situated within the area C in which the glowing cathode is clearly visible against a slight background haze which decreases in intensity as the pre-bias voltage increases.

The voltage required to switch a numerical indicator tube is equal to the pre-bias to place the operating point of the unused cathodes in the area C. The pre-bias voltage is of particular significance if the tube is to be operated from low voltage semiconductor scaling circuits. The required value of pre-bias voltage varies from tube to tube, however, being dependent on the cathode spacing. Typical values for satisfactory operation range from 40 to 120 V.

10.2.2 Operation from Unsmoothed Supply Voltages

The life of an indicator tube may be approximately doubled if it is operated from an unsmoothed half wave rectified supply provided that the peak current does not exceed the maximum recommended for the tube. Some loss of brightness will result, but this is not important unless the tube is used in bright sunlight.

ELECTRONIC COUNTING CIRCUITS

Some tubes (such as the GR10H) may be operated from an unrectified alternating supply. An additional electrode, called the a.c. anode, is placed so that the glow from it cannot be seen from the viewing position. The main anode is connected to the additional anode through a high resistance to facilitate the striking of the tube.

Numerical indicator tubes cannot be operated from either an unsmoothed rectified or an unrectified supply unless isolating buffer amplifying stages are employed between the counting circuit and the indicator tube, since counting circuits cannot be operated from unsmoothed supplies.

A number of methods have been published by which the amount of light evolved from an indicator tube can be reduced for operation in subdued light⁽⁴⁾. These circuits employ valve or transistor astable circuits so that the voltage supply is applied to the indicator tube for a fraction of the operating time. In conditions of high ambient lighting it is recommended that a red filter or a polaroid filter be placed in front of the tube to reduce reflections from the glass envelope and hence to increase the contrast of the display⁽⁴⁾.

10.3 THE Z550M INDICATOR TUBE^(7, 8)

The Mullard/Philips Z550M is a unique tube which has been developed to satisfy the need for a decade indicator tube which can be operated directly from the low voltage electrical readout provided by transistor scalars. It requires an input signal of about 5 V at a current of about 50 μ A. The form of the display is different from that of other indicator tubes. Ten figures are cut in the anode in the shape of the digits to be indicated; they are arranged in a circle, each digit being 3 mm in height. A gas discharge takes place behind one of the digits so that red light from the discharge shines through the cut away portion of the anode in the form of the digit to be indicated. The display can be quite bright, since the control circuit does not supply power to the main discharge.

The tube employs common anodes and common cathodes with ten separate trigger electrodes. The cathodes are in the form of a ring of molybdenum

as shown in Fig. 10.4(a). The shaded parts of the ring are coated with a material of high work function so that they do not emit electrons under ionic bombardment. The ring thus acts as ten separate cathodes. Two other rings are mounted 3 mm above and below the cathode ring and are connected together to act as the anodes. The digits are cut out of the upper anode ring. A wire trigger passes through the lower anode ring into the hole in the cathode ring as shown in Fig. 10.4(b). A trigger electrode can be used to initiate the discharge at the

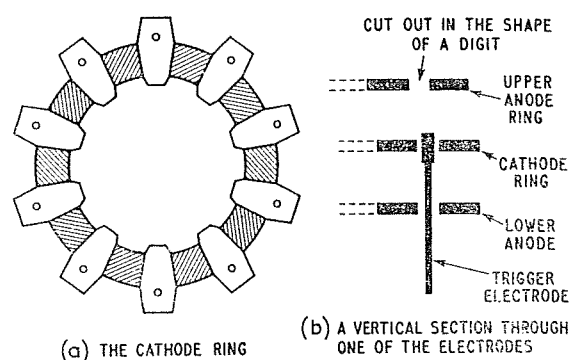

Fig. 10.4 The electrodes structure of the Z550M tube

desired position in the tube between the main anode and one section of the cathode. The tube is filled with neon containing a small percentage of argon, the total pressure being about 10 cm of mercury. Some material is sputtered from the cathode during manufacture so that the cathode surface is purified and the sputtered film which is deposited on the walls of the tube assists in the removal of contaminating gases.

The basic circuit in which this type of indicator tube can be used is shown in Fig. 10.5; for simplicity only two trigger circuits are shown. The power supply should be half wave or full wave rectified, but must not be smoothed. The trigger electrodes have a potential which is not very different from that of the common anodes provided that no discharge is taking place. A discharge between a trigger and the cathode can be initiated by a lower applied potential than is required to initiate a discharge between the anode and cathode. As the unsmoothed power supply voltage rises during a

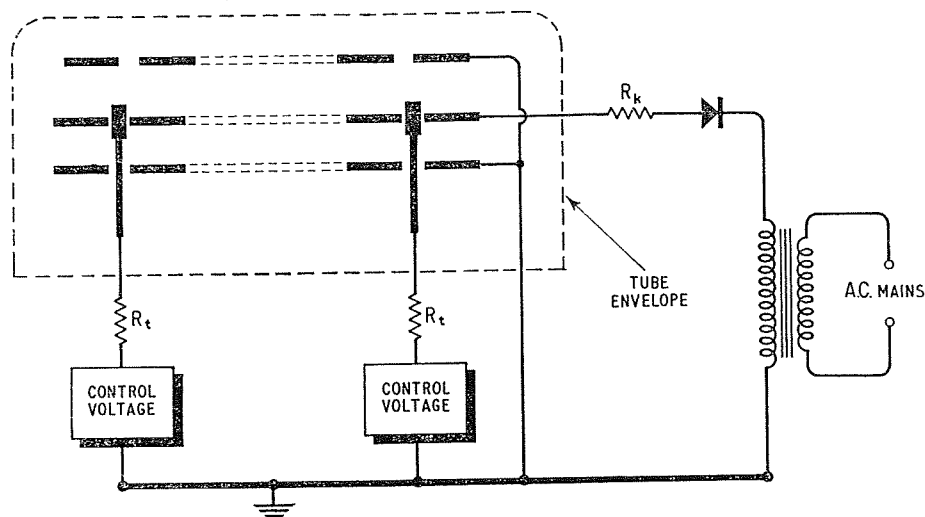

Fig. 10.5 The basic Z550M circuit

half cycle of the mains supply, a discharge will occur between the cathode and one of the trigger electrodes. If the current passing across this gap is large enough, the ions formed in this discharge will initiate a discharge between the main anode and cathode at the point at which the triggering discharge took place. The potential difference between the anode and the cathode then falls to the maintaining voltage for the tube and none of the other gaps can therefore reach their breakdown potential. The discharge ceases when the power supply voltage falls at the end of the half cycle. The process is repeated during a succeeding half cycle. Once a discharge has commenced at any point, a discharge cannot take place at any other point during the same half cycle of the power supply.

The position at which the triggering discharge occurs is controlled by the application of a small positive potential from the counting circuit to the desired trigger electrode so that the potential of this electrode is slightly higher than that of the other trigger electrodes. Its potential therefore rises to a value which is large enough to initiate a discharge before any of the other trigger gaps have reached their breakdown potential. At the next half cycle of the mains supply, the same trigger will initiate the discharge unless the counting circuit has switched the small additional potential to another trigger.

If the trigger voltage required for the initiation of an auxiliary discharge could be made exactly the same at all points in the tube, the tube could be operated by a very small control voltage. In practice, the trigger potentials required for ignition may vary by not more than 5 V and therefore the positive control voltage applied to the selected trigger electrode should not be less than this value. The differences between the ignition potentials of the various trigger to cathode gaps are minimised by the careful purification of the cathode surfaces. In addition the gas mixture is carefully chosen so that the trigger to cathode ignition potential is not strongly dependent on the electrode spacing.

The power supply frequency to the tube is quite important. It should not be so low that there is a noticeable flicker. On the other hand it should not be so high that there is not enough time for a gap to deionise between cycles of the power frequency or the glow will remain at one cathode indefinitely. The control voltage, which must be applied to the selected trigger electrode, increases at power input frequencies above 500 c/s and in excess of 3 kc/s it is not possible to alter the position of the discharge.

There is some statistical delay in the ignition of a trigger to cathode gap, since each discharge must be started by the presence of an electron in a suitable position. If there is a large statistical delay in the firing of one trigger to cathode gap, another gap

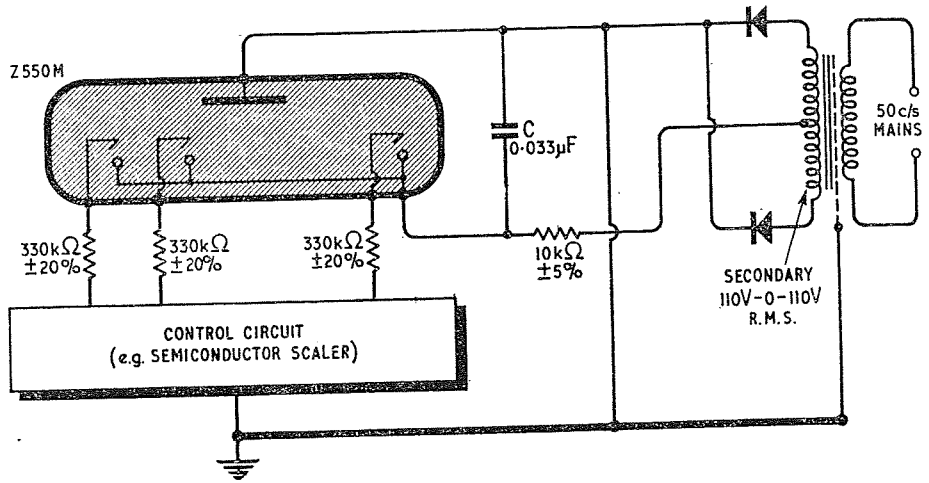

Fig. 10.6 A practical circuit for the Z550M.

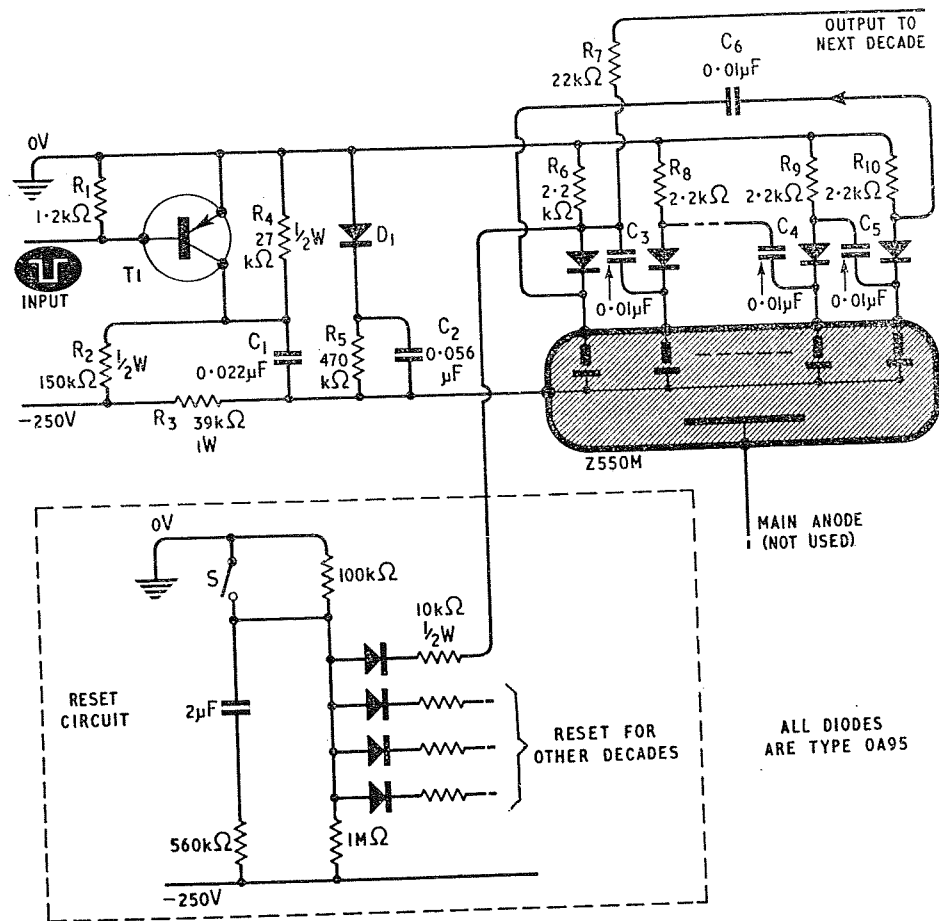

Fig. 10.7 A circuit for the operation of the Z550M as a scaler

may ignite during the delay time. This effect is minimised by the addition of a trace of radio-active gas to the tube; this gas provides electrons which can initiate the discharge. Nevertheless the power input frequency should not be too low or the gas will become almost completely deionised during the non-conducting period and this may cause a greater statistical delay in the striking of the tube.

A practical circuit for the operation of the Z550M indicator tube from a decade scaler is shown in Fig. 10.6. The scaler may employ PNP devices in a ring circuit to provide decade electrical readout which can drive the indicator tube. If a cascaded transistor binary circuit is employed in the scaler with feedback to convert the scale of 16 to a scale of 10, some means must be provided to convert the binary readout into decade readout to drive the indicator tube. Full wave rectification is normally preferred to half wave circuits. The capacitor, C , is used to prevent any voltage spikes from affecting the operation of the tube. The cathode current should be about 3 mA and the control circuit resistance in the trigger circuits should be between 100 and 470 k Ω . A power supply of between 90 and 130 V R.M.S. (nominally 110 V) at 40 to 100 c/s is suitable. The maximum potential between any trigger and the anode should be limited to 30 V and that between the anode and the other nine triggers not being used should be limited to ± 5 V.

10.3.1 The Operation of the Z550M as a Scaler

The Z550M was primarily developed for use as an indicator tube, but it can itself be used as a counting tube for frequencies up to 1 kc/s, only one driving transistor per decade being required. The tube may be used as an indicator in high speed transistor decades and as a counter in the succeeding slower but much more economical decades; a uniform type of readout is thus obtained from all decades.

A ring circuit in which the Z550M tube is used as a scaler is shown in Fig. 10.7⁽⁹⁾. In this circuit the trigger electrodes are used as anodes, the normal common main anode of the tube being left unconnected. The trigger electrodes should be regarded as the anodes of ten neon diodes which have a common cathode. Although an alternating power supply is

used with the tube when it is an indicator, a smoothed power supply must be employed to operate it when it is used as a scaler.

A negative going input pulse of 0.5 V in amplitude and 0.2 msec in duration applied to the base of the transistor $T1$ causes it to saturate. The amplified positive going pulse at its collector is fed via C_1 to the common cathodes of the tube. The collector of $T1$ is connected to the tapping of the voltage divider R_2-R_4 in order to reduce the collector to emitter voltage applied to $T1$ to a value within the ratings of this transistor. If the input pulse has a steep trailing edge, $T1$ is cut off so rapidly that a sudden large negative change in the common cathode voltage will occur and this could result in faulty counting. This difficulty can, however, be avoided by the use of D_1 , C_2 and R_5 . Any sudden negative going pulse in the common cathode line merely charges C_2 via D_1 . The values of C_2 and R_5 are chosen so as to ensure reliable operation of the circuit even if square wave input pulses are used. In addition, C_2 protects $T1$ against excessive transient voltages.

The tube counts on the same principle as the neon diode circuits of Chapter 3. When a positive going pulse from $T1$ is applied to the common cathodes, the trigger electrode which was passing current will be extinguished. A positive pulse of about 9 V in amplitude will occur in this trigger circuit and is capacitively coupled to the succeeding trigger electrode. This latter electrode will therefore conduct when the cathodes resume their normal potential at the end of the input pulse. The coupling in the reverse direction is not appreciable, since the coupling capacitor concerned is discharged via the two trigger resistors and a forward biased diode.

When the zero trigger gap strikes, a negative going pulse is produced at the output which is suitable for the operation of a succeeding identical decade. It is not essential to employ components corresponding to D_1 , C_2 and R_5 in any decade after the first, since pulses derived from a preceding decade have a suitable shape for the operation of a Z550M tube. When S is closed momentarily, a positive going resetting pulse is fed to the zero trigger electrode of all decades. The amplitude of this pulse is great enough to cause a current to flow

ELECTRONIC COUNTING CIRCUITS

in the zero trigger and cathode circuit which will increase the common cathode voltage to a value at which a discharge at any other trigger electrode will be extinguished. The diodes in the reset circuit prevent undesired coupling between the various decades.

The Z550M tube can also be used for reverse counting in the type of circuit shown in Fig. 10.8⁽⁹⁾; the input circuit should be similar to that of Fig. 10.7. For forward counting the line marked 'F'

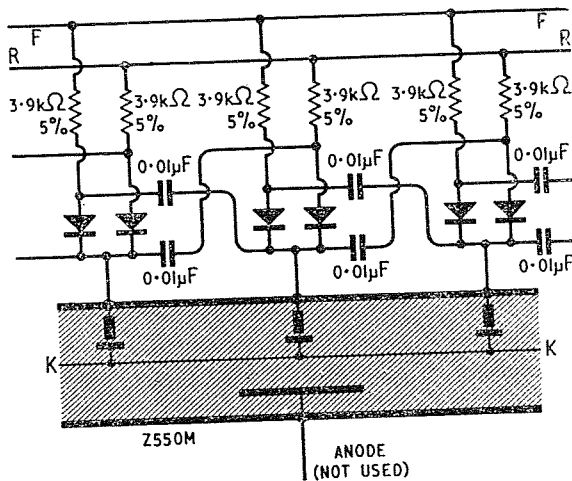

Fig. 10.8 The Z550M used in a reversible counting circuit

should be at least 15 V positive with respect to the line marked 'R', but for reverse counting the polarities of these lines should be reversed. In either case the input pulses should be positive going and are applied to the common cathode line, K. If the line 'F' is more positive than the line 'R', the conducting trigger electrode will take its current from the 'F' line and the diode connecting that trigger with the 'R' line will be reverse biased. The additional components therefore have little effect on the counting which proceeds in the forward direction as in the circuit of Fig. 10.7. If, however, the 'R' line is positive with respect to the 'F' line, the trigger electrode current will be taken from the 'R' line and counting will occur in the reverse direction.

In the reversible counting circuit of Fig. 10.8 the trigger electrodes are loaded by an extra capacitor and resistor; the pulses coupled from a preceding stage are therefore attenuated somewhat. For this reason the resistance values chosen should be rather

higher than those used in the circuit of Fig. 10.7 and should be of close tolerance. The common cathode resistor (not shown in Fig. 10.8) should have a value of 47 kΩ, ±2% (compare with R_3 of Fig. 10.7). The value of the voltage supply to this cathode resistor should be $-210\text{ V} \pm 2\%$ with respect to the line 'F' for forward counting or with respect to line 'R' for reverse counting.

10.4 ELECTROLUMINESCENT READOUT

Electroluminescence occurs when a suitable phosphor is excited by a changing electric field so that it emits light. A thin layer of the phosphor in a suitable dielectric (e.g. polystyrene) is placed between two conducting films (one of which is transparent) and the three layers are attached to a suitable base such as a sheet of glass or metal for mechanical support.

When an alternating potential is applied between the two conducting layers of the 'photo-capacitor's the phosphor emits light which passes through the transparent conducting film. The brightness and colour of the emitted light depend on the composition and thickness of the phosphor, the amplitude and frequency of the applied voltage and the temperature⁽¹⁰⁾. Such electroluminescent panels can be used for lighting purposes. The maximum amount of light which can be obtained from a given area of the phosphor is limited by the dielectric breakdown which occurs at high applied potentials.

The frequency of the applied voltage is important, since it affects the colour and the amount of light. The frequency of the emitted light is twice the frequency of the applied potential, but at higher frequencies the light output does not fall to zero between half cycles of the applied voltage. An increase in the frequency of the power input increases the number of times per second the charge of the capacitor is reversed. Hence an increase of power frequency increases the light output, but if the frequency is raised above about 1 kc/s the life of the phosphors being produced at present is reduced⁽¹¹⁾.

In order to display digits, the back electrode of an electroluminescent panel may consist of ten strips

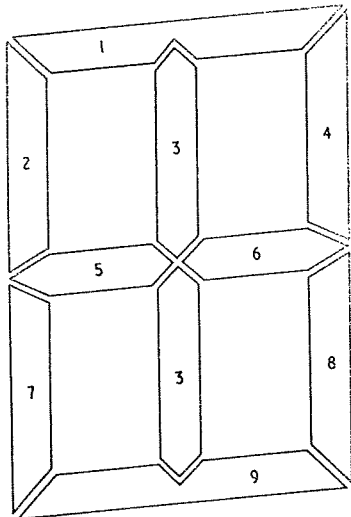

Fig. 10.9 The elements of a numeric panel

as shown in Fig. 10.9⁽¹¹⁾. This is known as a numeric display, since it is mainly intended for indicating numbers. The two strips marked 3 are connected together. The transparent conducting film acts as a common electrode for all ten strips. If selected combinations of the back electrodes are employed at any one time, any chosen digit can be indicated. For example, if the electrodes 1, 4, 6, 5, 7 and 9 are used, the digit two is indicated. If all the electrodes except those marked 3 are employed, the digit indicated is eight. Some letters can be formed using this type of display. For example, if the power

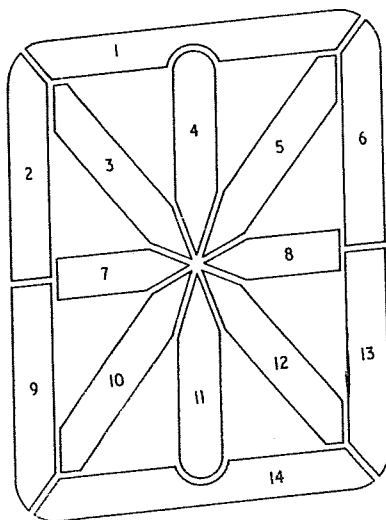

Fig. 10.10 The elements of a typical alpha numeric panel

supply is connected between the common transparent front electrode and the electrodes 7, 2, 1, 4, 8, 5 and 6, the letter *A* is indicated. Some letters, such as *K*, *R*, *V*, etc. cannot be formed by the use of this simple pattern of electrode strips.

The Ericsson Telephones 'Phosphotron' indicators types P22 and P23 employ the electrode pattern of Fig. 10.9 and indicate digits 1 in. high. These indicators require a 240 V R.M.S. supply at a frequency between 50 and 800 c/s. The current taken per electrode increases from 10 to 80 μ A and the surface brightness from 1 to 8 ft-lamberts as the frequency increases from 50 to 400 c/s. These display elements can be made virtually as large as desired; the Sylvania Company produce numeric indicators varying in size from $\frac{3}{8}$ to 10 in.

A slightly more complicated indicator employing more electrodes can be used to indicate any digit or any letter of the alphabet in addition to various other signs. The pattern of electrodes which may be used is shown in Fig. 10.10⁽¹²⁾. This type of pattern is known as an alpha numeric display. The letter *W*, for example, can be formed by using the strips 2, 9, 14, 11, 4, 13 and 6. Such indicators are available from the Sylvania company for displaying digits up to 10 in. high. A 'Phosphotron' of a similar pattern (type P40) is available from Ericsson Telephones Ltd. and indicates any digits or letters 4 in. high⁽¹¹⁾. This indicator employs two more electrodes than those shown in Fig. 10.10; they are placed at the upper and lower left-hand corners of the display. The P40 alpha numeric panel is used in the Ericsson Telephones relay decade counter unit type LJEQ 11/40 for readout.

Electroluminescent digital indicators have the advantages that they can be viewed from a very wide angle, occupy a very small volume, generate a negligible amount of heat and can be obtained in forms which display various colours and symbols of many types. Their main disadvantage is the complexity of the switching which is required to operate them. A transistor inverter is normally employed to provide the power supply for the operation of electroluminescent indicators, as the surface brightness of an indicator supplied with power directly from the 50 c/s mains is not normally adequate for use in an undarkened laboratory.

ELECTRONIC COUNTING CIRCUITS

The difficulty of switching the elements of the luminescent digital indicators may be overcome in the following way. The input signal is used to light one of ten luminescent strips in a separate unit. The light developed passes through certain holes in a mask and falls on parts of a photoconductive matrix. The parts of this matrix which conduct determine which elements of the separate numeric display will glow and hence which digits will be indicated. Similar combinations of electroluminescent panels, a dark mask and a photoconductive matrix can be used for converting binary information to the decimal form and vice-versa⁽¹²⁾. Combinations of electroluminescent and photoconductive devices can also be used in various types of logic and information storage circuits.

It appears that electroluminescent devices will find considerable application in counting equipment in the future, especially if a large clear display is required.

10.5 LOW POWER DIGITAL READOUT

Meter readout has the advantage that very little power or potential difference is required to operate it. This type of readout is therefore very suitable for use with transistor scaling circuits, no readout amplifiers being required. Errors can, however, easily be made in reading the state of the count from this type of analogue display. If, however, the meter needle is replaced by a film strip containing the ten digits and a suitable optical projection system is employed, digital readout can be obtained. When the current passing through the moving coil of the instrument changes, the film moves and the digit projected onto the screen is altered. This type of readout can provide a large and brilliant display. It has the advantage that it is operated from staircase waveforms and can therefore be used with almost any type of counting circuit.

A typical example of an indicator of this type is the Weston S462 digital indicator. The full scale deflection is $500 \mu\text{A} \pm 10\%$, but indicators with higher sensitivities can be designed. The digit nine should be adjusted so that it is in the centre of the screen when the full scale current is passing through the coil; the other digits will then be in their correct

positions when the appropriate proportion of the full scale current is being passed through the coil. A 6.3 V, 2 W lamp is used in the Weston system which projects a digit 1.25 in. high and can be viewed from about 30 ft. If a number of the indicators are placed side by side for a multidecade display, a single front screen may be used. Provision is made for a lamp to be fitted to each indicator to show the position of the decimal point. Indicators for various symbols are also available to show the units of the quantity being indicated.

10.5.1 Multi-Lamp Projection Systems

A method which can be used to obtain in-line digital readout from a number of lamps is shown in Fig. 10.11. One of the filament lamps at *A* illuminates the corresponding digit at *B*. The light passes to

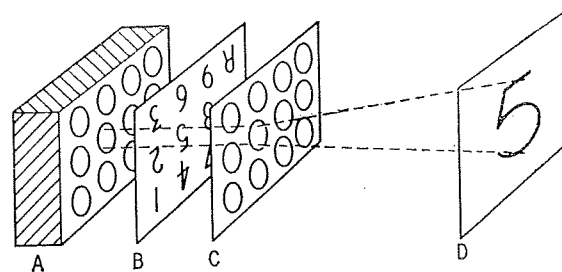

10.11 A digital projection system

the appropriate projecting lens at *C* which forms an image of the digit on the screen at *D*. The whole unit is placed in a suitable enclosure. This method of readout can produce large clear digits on a flat screen. It is, however, normally necessary to employ a relay to switch on each of the lamps which normally have a rating of about 2 W. Projection instruments occupy a larger volume than most other readout devices.

Multi-lamp projection indicators are available from Counting Instruments Ltd. for digits $\frac{5}{8}$, 1 or $3\frac{3}{4}$ in. high in any chosen colour. Other symbols and words may also be indicated. Similar units are available from the Burroughs Corporation.

10.5.2 Numeric Pattern with Indicator Bulbs

Another form of digital in-line display involves the use of a numeric pattern indicator such as that of

Fig. 10.9 in which each strip is cut out from a mask and is illuminated by a filament or neon bulb placed behind it. The pattern may be simplified somewhat by the omission of the strips marked 3 and by replacing the strips marked 5 and 6 by a single strip. This reduces the number of bulbs required to seven. If neon bulbs are employed, a matrix of resistors may be used to cause the appropriate neons to ignite when the matrix is fed with a suitable decade electrical readout of 150–250 V amplitude⁽¹³⁾. A slightly different form of readout may be used to operate the neons from a binary counting circuit⁽¹⁴⁾.

Recently gallium phosphide lamps have been used in numeric indicators⁽¹⁵⁾. Each line of the display consists of a number of the gallium phosphide diodes connected in parallel. The emitted light is red in colour. Although the diodes are ideal for use in solid state circuitry, since they are small, reliable and operate at small voltages and currents, they are not yet cheap enough for arrays of them to be employed in commercial instruments. The forward voltage drop across these diodes is only about 1.9 V.

10.5.3 Plate Type Indicators

Another type of digital indicator employs ten transparent plates mounted closely behind one another. The plates are normally made of plastic material, one digit being engraved on each plate. Ten filament lamps are placed so that any plate can be floodlit from the side by one of the lamps. The digit engraved on this plate will then be visible from the front through the other plates as a large number of small points of light. Such indicators provide a good clear display on a flat screen without the use of any projecting lenses. They can be viewed from a fairly wide angle and have the advantage that they occupy a smaller depth than systems which employ projection methods. A variety of plate type indicators are available from K.G.M. Electronics Ltd. for displaying digits and other symbols.

The Burroughs Corporation have published a report⁽¹⁶⁾ giving details of an investigation they have carried out to determine the legibility of various types of digital readout display from a distance and from an angle.

REFERENCES

1. 'Beam X Modules and Circuits', Burroughs Corp. Brochure 405, (1962).
2. G. HIGGINS, 'A gas-filled glow discharge character display tube' *J. Brit. I.R.E.*, **22**, 2, 133 (Aug. 1961).
3. N. M'CLOUGHLIN, D. REANEY & A. W. TURNER, 'The digitron: a cold-cathode character display tube' *Electron Eng.*, **32**, 385, 140 (1960).
4. 'Nixie Indicator Tubes', Burroughs Corp. Brochure 616.
5. 'Digitron Display Tubes', Ericsson publication B. 6207/2 issue 2.
6. 'Transistor Operation of Digitron Tubes', Ericsson publication no. P. 6105/1.
7. T. P. J. BOTDEN, 'A gas-discharge indicator tube for transistorized decade counting circuits', *Philips Tech. Rev.*, **21**, 9, 267 (1959/60). (Reprinted in revised form in Philips Report A.I. 806, (10th May 1961).
8. 'A decade indicator tube for transistorised scalars', *Electron. Appl. Bull.*, **21**, 3, 114 (1960/61).
9. 'Operation of the decade indicator tube Z550M as a scaler', *Electron Appl. Bull.*, **22**, 2/3, 115 (1961/62).
10. L. H. BRACE, 'Electroluminescent devices', *Wireless World*, **68**, 367 (1962).
11. 'Electronic Devices'. Physics Dept., Ericsson Telephones Ltd. B. 6110/1, issue 2.
12. 'Sylvania Electroluminescent Display Devices'. Sylvania publication ET-3975-8M-6-61. Also 'Sylvania I & M Panelescent EL Displays' Publication No. ET3937-10M-10-62.
13. I.D.E.A. Inc. (Indianapolis) publication.
14. W. GUNDELACH, 'Digitales Einzeilen-Anzeigegerät', *Elektron. Rundschau*, **11**, 325 (1957).
15. 'Electroluminescent GaP Diodes for Logic State Indicators and Visual Displays', Ferranti Application Report No. 29 (Sept. 1965).
16. 'Readout Fact Finder'. Burroughs Corp. report 20M261.

CONTENTS

		<i>Preface</i>	7
		<i>Acknowledgements</i>	9
Chapter	1	Introduction	11
	2	Electro-magnetic counters	32
	3	Single cathode gas filled counting tubes and their circuits	40
	4	Multi-electrode gas filled counting tubes and their circuits	67
	5	EIT decade counting circuits	154
	6	Beam switching tubes	181
	7	Valve scaling circuits	216
	8	Solid state scaling circuits	232
	9	Ratemeter circuits	276
	10	Readout	295
	11	Nuclear counting and instrumentation	310
	12	Further applications of counting circuits	341
Appendix		Valve equivalents and near equivalents	375
		<i>Index</i>	379

Appendix

Valve Equivalents and Near Equivalents

Many of the following valves are only near equivalents. No distinction has been made between special quality types and ordinary types. The valves listed are those used in the circuits in this book or those likely to be found in counting equipment. A few semiconductor equivalents are included.

ASG5121 (See CV797)
BD 302 (see CV5278)
B65 (see CV278)
B152 (see CV455)
B309 (see CV455)
B329 (see CV491)
B339 (see CV492)
B5031 (see GR10M)
CC3L, CV2213, NT2, CV2266.
CCT6, CV6016.
CV131, EF92, W77, V884, 9D6, CV4015, M8161,
E2016, 6CQ6, VP6, 6F21, 6065.
CV138, 6AM6, EF91, 6F12, Z77, R144, SP6, 8D3,
CV4014, 6064, PMO7, HP6, M8083, QA2403.
CV140, 6AL5, EB91, 6D2, EAA91, CV283,
CV4007, DD6, D77, D152, E91AA, 5726, 6097,
M8212, EAA901S, M8079, CV4025.
CV216, OD3, VR150/30, QS150/40, GD150/AS,
KD25, 150C3, GL150/30.
CV278, 6SN7, B65, 13D2, CV1988, CV3627.
CV283 (see CV140)
CV378, 53KU, GZ37.
CV432, ME1400.
CV448, OA81, GEX54, GEX55, 1N476, CV1353.
CV455, ECC81, 12AT7, 12AT7WA, E2157, B152,
B309, 6060, CV4024, ECC801S.
CV491, 12AU7, ECC82, E2163, B329, M8136, 6067,
CV4003, ECC186, ECC802S, 5814A.
CV492, 12AX7, ECC83, B339, E2164, 6057, 6L13,
M8137, CV4004, ECC803S, 12DM7, 12DT7.
CV493, 6X4, U78, EZ90, CV4005.
CV569, 6SL7, CV1985.
CV575, 5U4G, U52, CV841, CV1071.
CV593, GZ32, 5V4, 5AQ4.
CV797, EN91, 2D21, E1955, 20A3, PL21, PL2D21,
5757, M8204, CV4018, 4G/28OK, ASG5121.
CV841 (see CV575)
CV850, 6AK5, EF95, 5654, 731A, CV4010.
CV858, ECC91, 6J6, 6101, M8081, TS52, CV4031.
CV1054, EB34, D63, 6H6, OM3, CV554, CV1301,
CV1929, CV1930.
CV1376, EF80, 6BX6.
CV1535, EZ80, 6V4.
CV1739, GC10/4B, 6802.
CV1740, GS12C.
CV1832, GD150M, OA2, 150C3, QS1207, 4020,
6073, CV2903, CV4020.
CV1854, CV1856, 5Y3, U50, CV4027.
CV1862, 6AQ5, EL90, 6005, N727, CV4019.
CV1863, CV1864, 5Z4, R52, CV2748.
CV1929, CV1930 (see CV1054).
CV1985 (see CV569)
CV1988 (see CV278)
CV2127, 6CH6, EL821, EL803, 7D10.
CV2136, 6BW6.
CV2209, 6F33.
CV2213, (see, CC3L)
CV2223, G10/241E.
CV2224, G1/371K.
CV2271, GC10B/S, Z303C, 6482.

APPENDIX

CV2290, VX3163, GEX66, CV7110
 CV2325, GS10C, Z502S, 6476.
 CV2434, Z803U, GTE130T, 6779.
 CV2468, XC18.
 CV2492, E88CC, 6922, CCa, CV5231, CV5472.
 CV2748 (see CV1863)
 CV2975, EL84, 6BQ5, N709, EL171, 6EM5, 6P15.
 CV3627 (see CV278).
 CV3934, 1N34A, OA150
 CV4003 (see CV491).
 CV4004 (see CV492).
 CV4005 (see CV493).
 CV4007 (see CV140).
 CV4010 (see CV850).
 CV4014 (see CV138).
 CV4015 (see CV131).
 CV4018 (see CV797).
 CV4019 (see CV1862).
 CV4024 (see CV455).
 CV4025 (see CV140).
 CV4031 (see CV858).
 CV5072, EZ81, UU12, 6CA4, U709.
 CV5080, EF37A, OM5A, R121.
 CV5106, E1T, 6370.
 CV5122, Z900T, 5823, GTR80M, ASG5823.
 CV5143, GC10D.
 CV5149, 1N191.
 CV5173, 90C1, GD90M, QS1215.
 CV5214, E90CC, 5920, ECC960.
 CV5217, XC23.
 CV5231 (see CV2492).
 CV5277, ET51.
 CV5278, Z510M, BD302, 6844.
 CV5290, VS10G.
 CV5291, Z503M, GR10A.
 CV5348, GTE175M.
 CV5472 (see CV2492)
 CV5820, Z700U, Z70U, 7710.
 CV5842, GR10K.
 CV6016, CCT6.
 CV6044, GC10B/L.
 CV6100, GC10/4B/L.
 CV6103, VS10H.
 CV7004, OC45, CV5105, GET873.
 CV7007, OC77, 2N284A.
 CV7040, OA202, MS4-H.
 CV7047, OA5, CV7048.
 CV7110 (see CV2290).
 CV7114, OA211.
 DD6 (see CV140).
 D77 (see CV140).
 D152 (see CV140).
 EAA91 (see CV140).
 EB34 (see CV1054).
 EB91 (see CV140).
 ECC81 (see CV455).
 ECC82 (see CV491).
 ECC83 (see CV492).
 ECC91 (see CV858).
 ECC960, E90CC.
 ECC962, E92CC
 EF37A (see CV5080).
 EF91 (see CV138).
 EF92 (see CV131).
 EF95 (see CV850).
 EL83, 6CK6.
 EL84 (see CV 2975).
 EL90 (see CV1862).
 EL821 (see CV2127).
 EN91 (see CV797).
 ET51, CV5277, 6700.
 EZ80, CV1535, 6V4.
 EZ81 (see CV5072).
 EZ90 (see CV493).
 E1T, CV5106, 6370.
 E88CC (see CV2492).
 E90CC (see CV5214).
 E92CC, ECC962
 E2016 (see CV131).
 E2163 (see CV491).
 E2164 (see CV492).
 GC10B, GC10B/S (see CV2271).
 GC10B/L (see CV6044).
 GC10/4B, CV1739, 6802.
 GC10/4B/L, CV6100.
 GC10D, CV5143.
 GC10/2P, 6879.
 GD90M (see CV5173).
 GD150A/S (see CV216).
 GD150M (see CV1832).
 GEX34, GEX55 (see CV448).
 GEX66 (see CV2290).
 GL150/30 (see CV216).
 GR10A, Z503M, CV5291.

GI 0M, Z520M, TA542, ZM1020, B5031, 8037.
 GI10K, CV5842.
 GI 0C/S (see CV2325)
 GI 2C, CV1740.
 GI 80M (see CV5122).
 GI 120T, Z806W, ZC1020.
 GI 130T (see CV2434).
 GI 175M, CV5348.
 GI 2 (see CV593).
 GI 7, 53KU, CV378.
 GI 371K, CV2224.
 GI /241E, CV2223.
 KI 25 (see CV216).
 MI 1400, CV432.
 MI 81 (see CV858).
 MI 36 (see CV491).
 MI 137 (see CV492).
 MI 161 (see CV131).
 MI 212 (see CV140).
 NI 2 (see CC3L).
 NI 9 (see CV2975).
 O. 2 (see CV1832).
 O. 5, CV7047.
 O. 31 (see CV448).
 O. 202, CV7040, MS4-H.
 O. 45 (see CV7004).
 O. 3 (see CV216).
 O. 3 (see CV1054).
 O. 5A (see CV5080).
 PI 1, PL2D21 (see CV797).
 Q. 50/40 (see CV216).
 Q. 207 (see CV1832).
 Q. 215 (see CV5173).
 R. 1 (see CV1863).
 SI (see CV138).
 T. 542 (see GR10M).
 U. 1 (see CV575).
 U. 3 (see CV493).
 U. 9 (see CV5072).
 V. 5 (see CV131).
 V. 150/30 (see CV216).
 V. 0G, CV5290.
 V. 0H, CV6103.
 V. 4 (see CV131).
 W 7 (see CV131).
 X 18, CV2486.
 X 23, CV5217.
 ZC1020, GPE120T, Z806W.
 ZM1020 (see GR10M).
 ZM1021, Z521M.
 ZM1040, Z522M.
 ZM1050, Z550M.
 ZM1060, Z505S.
 ZM1070, Z504S, 8433.
 ZZ1000, 8228.
 Z70U (see CV5820).
 Z70W, Z700W, 7709.
 Z71U, Z701U, 7711.
 Z77 (see CV138).
 Z303C (see CV2271).
 Z502S (see CV2325).
 Z503M, GR10A, CV5291.
 Z504S, ZM1070, 8433.
 Z505S, ZM1060.
 Z510M (see CV5278).
 Z520M (see GR10M).
 Z521M, ZM1021.
 Z522M, ZM1040.
 Z550M, ZM1050.
 Z700U (see CV5820).
 Z700W, Z70W, 7709.
 Z701U, Z50T, 7711.
 Z803U (see CV2434).
 Z804U, 7713.
 Z806W, GPE120T, ZC1020.
 Z900T (see CV5122).
 1N34A (see CV3934).
 2D21 (see CV797).
 5A Q4 (see CV593).
 5V4 (see CV592).
 5U4 (see CV575).
 5Y3 (see CV1854).
 5Z4 (see CV1863).
 6AK5 (see CV850).
 6AL5 (see CV140).
 6AM6 (see CV138).
 6AQ5 (see CV1862).
 6BQ5 (see CV2975).
 6BW6 (see CV2136).
 6CA4 (see CV5072).
 6CH6 (see CV2127).
 6CK6, EL83.
 6CQ6 (see CV131).
 6D2 (see CV140).

APPENDIX

6F12 (see CV138).
6F21 (see CV131).
6F33, CV2209.
6H6 (see CV1054).
6J6 (see CV858).
6SN7 (see CV278).
6SL7, CV569, CV1985.
6V4, CV1535, EZ80.
8D3 (see CV138).
9D6 (see CV131).
12AT7, 12AT7WA (see CV455).
12AU7 (see CV491).
12AX7 (see CV492).
13D2 (see CV278).
53KU, CV378, GZ37.
90C1 (see CV5173).
150C3 (see CV216).
5654 (see CV850).
5726 (see CV140).
5814A (see CV491).
5823 (see CV5122).
5920 (see CV5214).
6057 (see CV492).
6060 (see CV455).
6067 (see CV491).
6073 (see CV1832).
6097 (see CV140).
6101 (see CV858).
6370, E1T, CV5106.
6476 (see CV2325).
6482 (see CV2271).
6700, ET51, CV5277.
6779 (see CV2434).
6802, GC10/4B, CV1739.
6844, Z510M, CV5278.
6879, GC10/2P.
6922 (see CV2492).
7710 (see CV5820).
7711, Z701U, Z50T.
7713, Z804U.
8037, Z520M, ZM1020.
8228, ZZ1000.
8433, Z504S, ZM1070.

Index

- Abraham and Bloch 23
- Acoustic memory system 354
- Activator, scintillation counter 327
- A.E.R.E. 1009E scaler 220
- Alpha numeric display 307
- Alpha numeric indicator tubes 298
- Alpha particles 310, 311, 313, 315, 327, 331, 332
- Alpha spectrometry 334
- Ambient illumination 49
- American tubes, 4 and 5 kc/s 117
 - 100 kc/s 117
 - basic data and connections 119
- Amplifier, cascode 314
 - Harwell-1049 314
 - very high gain 313
- Analogue display 308
- Analogue readout 20
- Analogue to digital conversion 363
- AND gate 30, 122
- Anode circuit capacitance 78
- Anode coupling 46
- Anode current 69-70
 - design for optimum 70
 - minimum 71
- Anode resistors 219
- Anode to guide voltage 77
- Anode voltage 72
- Anticoincidence circuits 31, 354
- Anticoincidence counting 338
- Argon 315, 319
- Astable circuit, transistor 26
- Astable multivibrator 23, 358, 364
- Astable valve blocking oscillator 28
- Asymmetrical bistable circuits 28, 236
- Asymmetrical tubes 68
- Automatic counting 359
- Automatic range change 294
- Automatic scaler 359
- Automatic transfer 110
- Automation processes 11
- Avalanche effect 260, 312
- Avalanche multiplication 260

- Background count 15
- Backward counting 43
- Barium titanate 273
- Batching 352
- Beam switching tubes 181-215
 - external readout 181
 - table of data 212
 - see also* Beam X; Trochotron
- Beam X switching tube 181, 202-15
 - 1 Mc/s circuit 203
 - 100 kc/s circuit 204
 - 10 kc/s circuit 204
 - cathode follower 204, 208
 - circuits using valves 203
 - circuits with transistor drive 210
 - construction of 202
 - decimal readout 203
 - low frequency circuit 208
 - methods of driving 203
 - resetting 208, 210
 - shielded 202
 - simple circuit 208
 - switching grids 202, 203, 210
 - table of data 213
 - target electrodes 202
 - use with numerical indicator tubes 203
- Beat frequency oscillator 294
- Beta particle 310, 311, 313, 315, 327, 331
- Beta spectroscopy 334
- Bias potential 301
- Bias voltage 25
- Bidirectional counters 46, 49, 51, 52, 69, 101, 104, 107, 262, 306 (*see also* reverse counting)
 - routing guides for 101
- Binary circuits 16, 25, 46
 - cascaded 17, 43, 238
 - decade counting using 17
 - valve 216
- Binary code 18, 363
- Binary counters, valve 216
 - zero state 216
- Binary counting circuits 28
- Binary-decimal code 363
- Binary electrical readout 222
- Binary scale 16
- Binary stages 19, 216
 - cascaded 217
 - zero state 232
- Biquinary counter 19
- Biquinary decade counter 50
- Biquinary indicator tube 298
- Bistable circuit 16, 227
 - asymmetrical 28, 236
 - cascaded 232
 - complementary symmetry 250
 - multivibrator 229
 - transistor 28, 232, 233
 - tunnel diode 265
- Bistable multivibrator 25, 189
- Bistable pulse shaping circuit 277

INDEX

- Blocking oscillator 28, 189, 270, 271
 transistor 29
 Blocking oscillator circuit 98
 Blocking oscillator driving circuit, transistor 87
 Blood cells, counting of 354, 355
 Bottoming 26, 28, 232
 Bottoming voltage 233
 Breakover voltage 259-60
 Bromine 319
 Burndept BE289 'Sensikator' 350
 Burroughs Corp., Beam X switching tubes 181, 202-15
- Cadmium sulphide photocells 57, 343, 344
 Cadmium sulphide nuclear radiation detectors 330
 Camera shutter speeds, determination of 357
 Capacitive transducers 349
 Capacitor coupling 216
 Capacitors, ferro-electric 273
 speed-up 25, 28
 tank 277, 283
 Carry gates 266
 Cascaded binary circuits 17, 43, 238
 Cascaded binary stages 217
 Cascaded bistable circuits 232
 Cascaded multivibrators 231
 Cascaded ternary circuits 231
 Cascaded transistor binary circuit 305
 Cascading tunnel diode circuits 265
 Cascode amplifier 314
 Cascode pair 87
 Cascode triodes 333
 Catching diode 179
 Cathode coupled multivibrator 140
 Cathode coupling 46
 Cathode current 300
 Cathode follower 95, 130, 204, 208
 circuit 322
 Cathode resistor 74
 Cathodes, in cold cathode tubes 41
 non-glowing 104, 105
 Cerberus decade selector tube 120
 basic data and connections 123
 preset counter 122
 reset 122
 Čerenkov detectors 328
 Čerenkov effect 328
 Chain circuits, tunnel diode 267
 Chain counter 49, 60
 Charge control transistor parameters 233
 Chlorine 319
 Clamping of collector potential 238
 Clamping circuit, diode 30
 Clamping diodes 77
 Clocks, digital 362
 Coding systems, special 254
 Coil impedance 32-35
 Coincidence circuit 30, 122, 195
 transistor 31
 Coincidence counting 335-38
 uses of 335
 Coincidence errors 354
 Coincidence gating 87
 Coincidence losses 356
- Coincidence resolving time 337
 Cold cathode counting tubes 40
 Cold cathode diode counting circuits 42
 Cold cathode diode ring circuit 44
 Cold cathode tubes, advantages of 40
 applications of 40
 cathodes in 41
 general description of 40-42
 Common anode resistor 56, 58
 Common cathode resistor 25
 Compensating resistors 301
 Complementary symmetry circuits 233, 237, 250
 Component tolerances 63
 Computing tubes 99
 Contact bounce 342
 Contact life 34
 Contacts, damage to 33
 Corrected counting rate 14
 Coulter counter 355-57
 Count rate measuring circuit 277
 Counter tubes 69, 93
 Counters, magnetic core 270
 Counting, automatic 359
 basic methods 11
 decade 16
 using binary circuits 17
 decimal 16
 of blood cells 354, 355
 of particles. *See* Particle counting
 of small objects 342, 348, 349
 predetermined 20
 principles of 16
 Counting circuits 20
 miscellaneous applications 341-73
 tunnel diode 264
 using special coding system 255
 Counting core 271
 Counting errors 14, 15
 Counting speeds 20-21, 32, 33, 40, 56, 60, 67, 68, 69, 75,
 76, 81, 91, 188
 Coupling, trigger to trigger 57
 Coupling circuits 138
 40 c/s 82
 400 c/s 83
 400 c/s, input circuit 85
 decade counter tubes 80
 Dekatrions 94
 transistor 86
 trigger tube, for double pulse tubes 82
 double pulse tubes, power supply for 85
 Coupling components 67
 Coupling tubes 51, 57
 Crystal controlled oscillator 358, 361, 366
 Cumulative effect 26, 29
 Cumulative process 25, 26
 Curie temperature 273
 Current for cathode coverage 300
 Current sharing 74
 Current/voltage characteristic curve 183
- Dark current 326, 327
 d.c. restoring diode 83

- DCTL. *See* Direct Coupled Transistor Logic
- Dead time 14
- Decade circuit, economical 238
transistor 238
tunnel diode 267
with GR10A readout 221
- Decade counting 16
using binary circuits 17
- Decade counting circuit 12
- Decade counting tubes 12, 352
- Decimal counting 16
- Deflector plates 155
- Deionisation times 59, 66
- Dekatrons 93-113, 342, 346, 359, 361, 366
anode resistors 94
base connections 114
basic data 113
coupling to magnetic counters 111
coupling circuits 94
coupling Trochotron to 195
digital indication from 103
Digitron operation 104
Digitron readout 103
hard valve coupling 94
input circuit for 95, 111
input circuit techniques 107
low voltage 101
power supply 116
reset 96
sine wave input for 95
single pulse 69, 108
transistor drive circuits 98
12-way 107
- Delay 18, 26, 71, 78, 87
- Delay line, mercury 354
- Differentiating circuit 22, 35, 162
transistor 35
- Differentiating transformer 251
- Diffused junction detectors 331
- Digital clocks 362
- Digital frequency meters 362
- Digital indication from Dekatron 103
- Digital indicator tubes 91, 300
- Digital indicators, electroluminescent 307
Weston S462 308
- Digital multi-meters 363
- Digital readout 20, 56, 57
from trigger tube circuits 53
reversible counting with 107
- Digital voltmeters 362-68
integrator or voltage to frequency conversion technique 366
potentiometric or successive approximation technique 363
ramp technique 365
- Digitron 297
cathodes 103, 104
numerical indicator tube 192
operating requirements 103
readout 103, 107
- Digits 11, 37
- Diode, in differentiating circuit 22
zener 364
- Diode clamp 51, 83
- Diode clamping circuit 30
- Diode coupling 219
- Diode gate 19, 220, 235, 247
- Diode matrix 239, 246, 250
- Diode pump 293
- Diode pump circuit 278, 281, 289, 291
- Direct Coupled Transistor Logic 233
decade 242
- Discharge 41, 68
blue 134
in trigger tube 45
- Discharge transfer 44, 67, 74
- Discrimination against hum voltages 367
- Discriminator 314, 316, 317, 322, 329
- Display 19, 32, 221, 295-309
'In-line Digital' type 295
- 'Divide by sixteen' circuit 17
- 'Divide by two' stage 17
- Divided load resistor 322
- Division 69, 117
- Dosimetry, thermoluminescent 339
- Double pulse counting, principles of 72
- Double pulse decade tube, Raytheon 117-19
Sylvania 117-19
- Double pulse Dekatrons 93
- Double pulse selector tube 90, 98
- Double pulse tubes 67, 69, 71, 79
anode capacity 78
cathode resistor 74
circuits for 79
guide bias circuit 77
guide bias values 74
guide integrator circuit 78
input pulses 75, 80
maximum counting speed 76
Mullard input circuit for 79
Mullard valve coupling circuit for 80
negative cathode bias 74
output pulse shape 75
pulse amplitude 76
pulse duration 76
resetting to zero 81
sine wave drive 89
trigger tube coupling circuits 82
power supply for 85
- Drive circuits, transistor 98
- Dynaquad 259, 264
- Dynodes 325
- E1T. *See* Mullard Philips E1T
- Eccles-Jordan circuit 25
- Eccles-Jordan stage 61
- Ecko N530F automatic scaler 221, 359
- Ecko ratemeters 288, 292
- Economical decade circuit 238
- Electric fields 181
- Electrical discharges 46
- Electrical impulses. *See* Pulses
- Electrical pulses. *See* Pulses
- Electrical readout 69

INDEX

- Electrical symbols 297
- Electrodes, locking 152
 - star shaped 146
- Electroluminescent digital indicators 307
- Electroluminescent readout 306
- Electromagnetic counter 32-39, 116, 141, 144
 - advantages 20
 - circuits 33-37
 - disadvantages 20
 - predetermined 33
 - use with EIT tube 178
- Electromagnetic register 11, 21, 32
 - maximum speed 12
- Electron paths in mutually perpendicular magnetic and electric fields 181
- Electrostatic force 182
- Elesta counting tube 68
- Elesta decade selector tube 134
 - 1 Mc/s input circuit 137
 - 10 kc/s transistor input circuit 143
 - 100 kc/s coupling circuit 140
 - 100 kc/s input circuit 136
 - 100 kc/s transistor input circuit 142
 - 500 kc/s input circuit 137
 - anode current 135
 - anode current range 138
 - anode stray capacitance 135
 - anode supply voltage 135
 - basic data and connections 144
 - blocking oscillator circuits 142
 - cathode circuits 135
 - circuit tolerances 136
 - comparison of types EZ10B and EZ10A 134
 - coupling circuits 138
 - digital display 144
 - input pulses 135
 - shaping circuit 143
 - output pulses 135
 - power supply unit 140
 - predetermined counting 142
 - relay output circuit 140
 - reset circuit 140
 - transistor circuits 142
- Elesta reversible selector tube 146
 - 1 Mc/s decade 150
 - 100 kc/s stage 148
 - basic data and base connections 151
 - input pulse shaping circuit 149
 - power supply voltage 149
 - pulse shaping circuit 149
 - readout 148
 - reset 148
- Elesta ring counter 52
- Elesta tubes 70, 134
- Elliot flow transmitter 351
- Emitter followers 237
- End viewing tubes 298, 300
- Energy spectrometry 328
- Engine speed indicator 294
- Equipotential lines 181, 182, 184, 186
- Ericsson K20 photoconductive cell 343
- Ericsson tubes 93-113, 181
 - basic data 64, 113, 212
- External magnet 153, 183
- Extinction 56
 - by fall of anode voltage 68
 - of discharge 73
 - of tube 42, 45
- Extinguishing circuits 46
- Extinguishing electrodes 92
- Extinguishing pulse 49
- Fall time 13
- Feedback 18, 19, 23, 238, 239, 281, 284
- Feedback circuit 278
- Feedback loop 23, 49
- Ferrite core 29
- Ferrite tubes 251
- Ferro-electric capacitors 273
- Ferro-electric crystals 273
- Ferro-electric materials with rectangular hysteresis loops 270
- Field effect transistor input stages 334
- Filter, high pass 22
 - low pass 23
- First guide pulse 72
- First guides 68
- Five binary decimal counters 257-59
- Flip-flops 26
- Flow rate 11, 351
- Flow techniques 354
- Fluorescent coating 154
- Fluorescent target 155
- Flux counters 270
 - circuits 272
- Flyback circuit 169, 170
- Flying spot 353, 354
- Formative delay 46
- Four layer diodes 259, 260
- Four layer PNP structure 259
- Four layer switching devices 259
- 4π counting 315
- Fraction indicator tube 297
- Frequency of oscillation 28
- Frequency divider 23, 272
- Frequency measurement 361
- Frequency meter 276, 294
- Gallium arsenide 330
- Gallium phosphide indicator lamps 309
- Gamma ray energy spectrometry 328, 330
- Gamma spectroscopy 334
- Gas amplification factor 312, 318
- Gas counting 315
- Gas-filled counting tubes, multi-electrode 67-153
 - single cathode 40-66
- Gas-filled photocell 343
- Gas-filled radiation detectors 311-13
 - circuit 312
- Gate current 260
- Gating, transistor 259
- Gating circuits 30-32
- Gating diode. *See* Diode gate
- Geiger-Müller counter 318-25
 - accuracy 323
 - errors 323

- Geiger-Müller region 312
 Geiger tube 13
 characteristics 320
 high current 324
 maximum counting rate 318
 output pulses 320
 principle of operation 318
 probe units 320
 quenching in 319
 temperature coefficient 324
 transistor probe circuit 323
 types of 324
 Germanium radiation detectors 330, 331
 Glow discharge 76
 Glow transfer 67
 Goto counter 265
 Gray code 257
 Grid stopper resistors 220
 Guanidine aluminium sulphate hexahydrate 273
 Guide bias 73, 74, 89, 95, 98
 circuit 77
 Guide cathode 68, 72, 108
 Guide currents 78
 Guide electrodes 68, 71
 Guide integrator circuit 78
 Guide priming 72
 Guide pulses 76
- Halogen tubes 319
 Hartley oscillator 350
 Harwell quenching unit 320
 Harwell-1049 amplifier 314
 Harwell-1067 coincidence unit 337
 Health monitoring instruments 313
 Heterodyne frequency peaks 362
 High speed counters 60
 Holding current 259
 Hole storage effects 28
 H.T. supply voltage, minimum 71
 Hydrogen-filled tube 134, 147
 Hysteresis loop, rectangular 270
- Ignition voltage 245
 Ignitron tubes 371, 372
 Indicator bulbs 308
 Indicator tubes 53, 68
 biquinary 298
 characteristics of 300
 digital 91, 300
 fraction 297
 gas-filled cold cathode 297
 letter 297
 Mullard/Philips Z550M 302
 numerical 69, 299
 circuit 300
 operation from unsmoothed supply voltages 301
 plus and minus sign 301
 point 298
 table of data 299
 table of data 298
 Industrial applications, miscellaneous 341
 Inert gases 40
 In-line numerical readout 91
- Inoperative time 14
 Input channels, isolating 31
 Input circuit for Dekatrons 95
 Input pulses, timing of 68
 Integrating circuit 22, 78, 87, 91, 95, 277
 time constant 98
 Interference 220
 Internal resistance of the bias supply 77
 Inverse tubes 151
 Ion removal 59
 Ionisation 66
 Ionisation chambers 311
 pulse 313-15
 Ionisation coupling 104
 Ionisation time 59
 of trigger tube 46
 Ions 67, 310, 311
- Leading edge 13
 Leak resistor 277, 291
 Letter indicator tubes 297
 Life of polycathode gas filled tube 70
 Limiting diode 98
 Liquid flow measurement 251
 Lithium drifted detectors 331, 334
 Locking electrodes 152
 Logic circuit 259, 294
 Low level diode logic circuit 259
- Magnetic core 270
 rod like 272
 Magnetic core counters 270
 wide temperature 271
 Magnetic counter, operation 144
 Magnetic field 181, 184, 186, 187, 188, 193
 Magnetic materials with rectangular hysteresis loops
 270
 Magnetic memory system 354
 Magnetic readout 272
 Magnetic reset 33
 Magnetic transducers 349
 Magnetic scalars 21
 Magnetically biased tubes 152
 Magnetically reset counters 34
 Main cathode 68, 69, 71
 Maintaining voltage 41, 42, 44, 47, 49, 63, 67, 72, 74,
 76, 79
 Majority carriers 265
 Mark to space ratio 25, 77
 Maximum current 71
 Mean count 15
 Mercury delay line 354
 Meter readout 12, 239, 247
 Methane 315
 Microphonic pick-up devices 348
 Microscopic particles. *See* Particle counting
 Micro-switch 341
 Miller effect 23, 233
 Miller integrating valve 288, 289
 Miller integrator 365
 Miller-Pierce crystal controlled oscillator 349
 Minority carriers 233, 265
 Module construction 86, 87, 170, 210

INDEX

- Monostable circuit 25, 29, 35, 79, 179
 - transistor 28, 36
- Monostable multivibrator 25, 95, 111, 140, 159, 161, 162, 169
- Monostable pulse shaping circuits 277
- Multi-cathode tubes 40
- Multi-decade counters 32
- Multi-electrode counting tubes 67
- Multi-meters, digital 363
- Multiple anode counting tubes 151
- Multivibrators 23, 167
 - astable 23, 358, 364
 - bistable 25, 189, 229
 - cascaded 231
 - cathode coupled 140
 - monostable 25, 95, 111, 140, 159, 161, 162, 169
 - transistor circuits 26
- Mullard input circuit for double pulse tubes 79
- Mullard/Philips cold cathode decade tubes 79-93
 - table of basic data 92
- Mullard/Philips E1T decade counter 154-80
 - 2 kc/s circuit 171
 - 10 kc/s circuit 170
 - 30 kc/s circuit 164
 - 30 kc/s coupling circuit 161
 - component tolerances 162
 - 30 kc/s input circuit 162
 - 30 kc/s module 170
 - 30 kc/s stages 170
 - 100 kc/s circuit 166
 - 100 kc/s input circuit 167
 - abridged data 179
 - anode characteristics 156, 158
 - anode resistor 161
 - auxiliary pulse shaper 163
 - beam stability 157
 - cathode resistor 170
 - counting process 158, 159
 - criterion of stability for any operating point 158
 - cut-off time 160
 - electrodes 155
 - electronic presetting stage 176
 - flyback circuits 159, 169, 170
 - flyback time 171
 - input circuit 166
 - input pulse 158, 159, 177
 - input stage 173
 - marginal tests 169
 - maximum frequency of operation 160, 171
 - operating notes 179
 - other scales 179
 - output stage 176
 - practical details 170
 - predetermined counting 173
 - principle of operation 154
 - pulse rise time and amplitude 158
 - pulse shaper 167
 - random pulse counting 170
 - readout 154
 - rectangular cross beam 155
 - reset 156, 159
 - involving beam cut off 160
 - reset anode 155, 159, 161
 - reset anode resistor 172
- Mullard/Philips E1T decade counter *continued*
 - reverse counting 179
 - ribbon shaped electron beam 154, 156
 - self-indicating 154
 - sinusoidal signals 163
 - stabilising effect of *C* on 159
 - stabilising mechanism 158
 - stable working points 158
 - switched presetting 178
 - tube selection 169
 - use with electro-magnetic counter or relay 178
- Mullard/Philips Z550M indicator tube 302
 - operation as scaler 305
- Mullard valve coupling circuit for double pulse tubes 80
- Mu-metal screen 188
- N gate 259, 264
- N* (negative) currents 185,
- Negative cathode bias 74 265
- Negative edges of input waveform 218
- Negative resistance effect 183, 265
- Neon 319
- Neon bulbs 309
- Neon diode circuits 305
- Neon glow 53
- Neon readout from transistor scalars 242
- Neon tubes 219, 220, 227, 230, 231, 242, 262, 297
- Neutron spectrometers 335
- Neutrons 310
- Nitrogen 315
- Nixie numerical indicator 203, 250, 262, 297
- Nodistron 297
- Nomotron counting tube 68
- Nomotron decade selector tube 70, 124
 - 5 kc/s circuit 125
 - 20 kc/s circuit 127
 - basic data 133
 - cathode circuit time constants 124
 - circuit for 125
 - coil resistance 132
 - electrical reset 127
 - hard valve coupling circuit 129
 - input circuit 128
 - input pulse requirements 127
 - operation from 50 or 60 c/s a.c. mains 131
 - operation of relays from 132
 - relay 124, 134
 - reset 127
 - shield 124
 - sine wave drive 130
 - structure of tube 124
 - trigger tube coupling 130
- Non-saturating binaries 251
- Non-saturating circuits 237
- Nuclear counting 310-40
 - principle of 310-11
- Nuclear physics 11
- Numeric pattern 308
- Numerical indicator tubes 69, 151, 298
 - circuit 300
 - readout from transistor scalars 246
- Numericator 297
 - readout 56
- Nuvistor valves 203

- Operations, switching 19-20
 Optical pick-up heads 342
 OR gate 31
 Oscillator, blocking. *See* Blocking oscillator
 crystal controlled 358, 361, 366
 Hartley 350
 Miller-Pierce crystal controlled 349
 relaxation 23
 Oscilloscope 13, 178
 Overlapping pulses 75
- P gate 259, 262
 Particle counting 352-57
 colloidal particles 355
 planar field methods 353
 virus 357
 wide track or line scanning systems 354
 see also Blood cells
 Particle identification 335
 Particle size distribution determination 352
 Percentage error 13, 14
 Phase relationship between two signals 362
 Phase shift control 372
 Phosphor scintillation counter 327
 Phosphors 325
 Phosphotron 307
 Photocathode 325
 Photocell 11, 359
 circuits 342
 gas-filled 343
 Photoconductive cell 57, 344
 Photocoupling 57
 Photodiode 335
 junction 345
 Photoelectric pick-up 137
 Photoelectric transducers 342
 Photoemission 42
 Photoextinction methods 354
 Photomultiplier noise 326, 327
 Photomultiplier tube 325, 328, 335, 353, 354
 Photosensitive circuits for driving decade tubes 346
 Photosensitive devices 342
 Phototransistor circuits 345
 Photovoltaic diodes 345
 Photran 348
 Pick-up devices 341
 microphonic 348
 Pick-up heads, optical 342
 'Pixie' tube 299
 Planar field methods of particle counting 353
 Plate type indicators 309
 PN junction 330, 345
 PNPN devices 259-60, 305
 PNPN diodes 260
 PNPN light actuated switch 348
 P.O. 100 type counters 32, 36, 179
 Point indicator tube 299
 table of data 299
 Polyatrons 152
 Polycathode tubes 40, 67
 life of 70
 Positrons 310
 Post Office register 32, 36
- Potassium niobate 273
 Potential divider 80, 81, 83, 85, 137, 173
 Potentiometers 176
 presetting 177
 Power supply, Dekatron 116
 rectified unsmoothed a.c. 103
 trigger tube coupling circuits for double pulse tubes
 82, 85
 Power supply frequency 303
 Power supply unit 141
 Pre-bias 301
 Predetermined counters 33, 352
 Predetermined counting 20, 63, 142, 173
 Pre-scalers 21
 Preset counter 33
 Presetting potentiometers 177
 Priming 41, 72
 Priming anode 42
 Priming cathode 42, 50, 51
 Priming current 93
 Priming discharge 59
 Priming electrodes 67
 Priming resistor 85
 Print out 20, 32
 Printed circuits, miniature 232
 Probe current 93, 134
 Production line 11
 Projection systems 308
 Proportional counters 315-18
 operating conditions 316
 resolving time 318
 stability 318
 statistical errors 317
 Protons 311
 Proximity switch 349
 Pulse amplitude 13, 30
 analyser 329
 limiting circuit 277
 Pulse circuits 26-31
 Pulse duration 13, 35
 Pulse generator 15
 Pulse height analyser 355
 Pulse height discriminators 279
 Pulse ionisation chambers 313-15
 Pulse length 35
 Pulse routing 364
 Pulse shaper 167, 173
 Pulse shaping 22, 26, 167, 173
 circuits 13, 277
 Pulse squarer 167
 Pulses 11, 12
 closely spaced 13
 duration 26
 evenly spaced 13, 14
 'ideal' 12
 random 13-15
 rectangular 12, 22, 23, 26, 28, 35
 sharply defined 22
 Pumping core 271
- Quenching in Geiger tube 319
 Quadrant diagram, trigger tube 45

INDEX

- Radiation 310
- Radiation detectors, gas-filled 311-13
 - semiconductor 329-30
- Radiation monitor 279
- Random pulse counting 170
- Rate measuring circuits 279
- Ratemeters 12, 276-94
 - accuracy 281
 - advantages and disadvantages of 276
 - auto-correction for lost counts 284
 - automatic control of time constant 288
 - circuits 279-94
 - construction 276-79
 - linear 278, 281, 284
 - logarithmic 289
 - statistical errors 279
 - transistor 292
 - uses 276
- Raytheon double pulse decade tube 117-20
- Readout 19, 33, 221, 227, 239, 250, 295-309
 - analogue 20
 - binary 219
 - binary coded decimal 295
 - decade electrical 305
 - digital 20, 56, 57, 295, 297
 - from trigger tube circuits 53
 - Digitron 103
 - electrical 69, 295
 - electroluminescent 306
 - in-line digital 308
 - in-line numerical 91
 - low-power digital 308
 - magnetic 272
 - meter 239, 247
 - neon, from transistor scalars 242
 - Numicator 56
 - systems for magnetic core counters 270
 - types of 296
 - visual 20, 148
- Rectangular pulses 28, 75, 77
- Relaxation oscillator 23
- Relay 37, 47, 63, 66, 141, 144, 177, 195
- Relay chatter 343
- Relay tube. *See* Trigger tube
- Reset 34, 39, 78, 81, 85, 96, 188, 208
- Reset anode resistor 172
- Reset circuit 141
 - resistor in 103
- Reset switch 193
- Resistor tolerances 62
- Resistors, compensating 301
 - in resetting circuit 103
 - leakage 291
 - tolerances 62
 - voltage dependent 116
- Resolving time 13, 216, 217, 220, 235, 255, 288
 - corrections for 14
 - determination of 15
 - valve counting circuits 219
- Reverse counting 32, 43, 46, 49-52, 56, 73, 101, 179, 231, 251, 262, 306 (*see also* bidirectional counters)
- Reverse current 70
- Reversible counting with digital readout 107
- Reversible counting circuit 306
- Reversible transistor decade counters 247
- Revolution indicators 293
- Ribbon shaped electron beams 156
- Ring circuits 19, 232, 257, 305
 - high power 264
 - tunnel diode 269
- Ring counter 43, 52
 - transistor 250
 - trigger tube 49
- Ring of two circuit 46
- Ring type scaling system 46, 272
- Ring valve bistable circuits 229
- Ring valve counting circuits 227
- Rod like magnetic cores 272
- Rossi coincidence circuit 31
- Rotation speed measurement 349
- Routing calls in telephone systems 352
- Routing guides for bidirectional counting 101
- Scale of two 16
- Scale of three 16
- Scale of five 16
- Scale of ten 17-19
- Scale of twelve 16, 18, 59
- Scale of sixteen 19
- Scalars 12, 21
 - automatic 359
 - transistor. *See* Transistor scalars
 - Z550M used as 305
- Scaling circuits, solid state 232-75
 - valve 216-31
- Scaling factor 12
- Schmitt trigger circuit 25, 96, 128, 138, 149, 348, 350
- Scintillation counters 318, 325-29
 - activator 327
 - errors 328
 - liquid 327, 328
 - phosphor 327
 - principle of 325
 - working conditions 328
- Set zero switch 184
- Second guide pulse 73
- Second guides 68
- Selector tube 69, 93
 - double pulse 98
- Self extinguishing circuit 51
- Self indicating devices 20, 40
- Semiconductor equivalents 375
- Semiconductor junction detectors 330-35
 - applications 334
 - instrumentation 331
- Semiconductor materials 329, 344
- Semiconductor radiation detectors 329-30
- Semiconductors, tunnelling effect in 265
- Sensikator, Burndep BE289 350
- Shockley diode 259, 260
- Side viewing tubes 298, 300
- Silicon controlled rectifier 259
- Silicon controlled switch 259, 264
- Silicon diodes 262
- Silicon radiation detectors 330, 331
- Sine wave circuit 111
- Sine wave drive 89

- Sne wave input for Dekatrons 95
 Sne waves 98
 iimultidecade counter for 90
 Single cathode tubes 40
 Single digit counters 37-89
 Single pulse Dekatron 69
 Sinusoidal signals 163
 Small objects, counting of 342, 348, 349
 Solid state scaling circuits 232-75
 Space charge effects 181, 184
 Spade electrodes 183
 Spade load resistor 185
 Spade potential 187
 Spade recovery time constant 187
 Spade resistors 185, 187-89, 199-201
 Spade supply voltage 189, 192
 Sparking 116
 and spark suppression 33-34
 Speed-up capacitor 25, 28, 235
 Spurious counts 219
 Spurious pulses 342
 Sputtering 40, 70, 151, 300
 Stabilised H.T. supply 70
 Stabiliser tubes 62
 Stabilisers 56
 Staircase waveform 178, 295, 308, 352, 366
 Standard Telephone & Cables Ltd. 124
 Starter. *See* Trigger electrodes
 Starter capacitor 47
 Statistical delay 46, 303
 Statistical error 15, 317
 Statistics of counting 15
 Steep trailing edge 78
 Stepped waveform 352
 Stray capacitance 63, 98, 117, 166, 167, 169, 202, 210, 322
 Striking voltage 41, 43, 44, 67, 72, 78, 245
 Subtraction. *See* Reverse counting
 Supply voltage 63
 H.T., minimum 71
 maximum value of 71
 minimum value of 71
 Surface barrier detectors 331
 Switch, electronic 176
 Switching 16
 Switching devices, four layer 259
 Switching grid bias 192
 Switching grid current 191
 Switching grids 186, 189, 191, 199, 203
 rod shaped 200
 Switching operations 19-20
 Switching tube circuits 21
 Sylvania double pulse decade tubes 117-20
 Symmetrical tubes 68

 Tachometer 341, 342, 349
 Tank capacitor 277, 283
 Target current 187, 193
 Target resistor 193
 Target voltage 203
 Telephone systems, routing calls in 352
 Temperature compensation 346
 Ternary circuits, cascaded 231
 valve 230

 Ternary scale 16
 Thermal delay switch 373
 Thermal hysteresis effect 45
 Thermoluminescent dosimetry 339
 Thermoluminescent techniques 339
 Thyatron circuits 66
 Thyatron tubes, operation of magnetic counters 37
 Thyatrons 177, 277, 371, 372
 Time constant 22, 30, 91, 98, 235, 277, 279
 Time intervals 368
 measurement of short 357
 Time markers 368
 Time measurement 30
 Timer circuit, trigger tube resistance-capacitance 373
 Timers for welding 369-73
 Timing, use of counting circuits 357-73
 Tolerances, component 63
 resistor 62
 Townsend avalanche 312
 Townsend current 41
 Trailing edge 13
 Transducers, capacitive 349
 magnetic 349
 Transfer cathode 68, 71
 Transfer characteristic 73
 Transfer current 44
 Transfer discharge 79
 Transfer electrodes 68, 71
 Transfer potential 78
 Transfer sensitivity 70
 Transfer time 78
 Transfer voltage 78
 Transformer, blocking oscillator 28
 differentiating 251
 Transformer coupling 47
 Transient change 12
 Transistor astable circuit 26
 Transistor binary circuit, cascaded 305
 Transistor bistable circuit 28, 232, 233
 Transistor blocking oscillator 29
 driving circuit 87
 Transistor circuits 26, 142, 144, 148
 Transistor coincidence circuit 31
 Transistor coupling circuit 86
 Transistor decade circuits 238
 Transistor decade counters, reversible 247
 Transistor differentiating circuit 35
 Transistor drive 210
 circuits 98
 Transistor gating 259
 Transistor Geiger tube probe circuit 323
 Transistor input stages, field effect 334
 Transistor inverter 307
 Transistor monostable circuit 28, 36
 Transistor multivibrator circuits 26
 Transistor ratemeter 292
 Transistor ring counter 250
 Transistor saturated decade, 10 Mc/s 247
 Transistor scalars 232
 200 Mc/s scale of eight 254
 circuits 308
 fast 251
 neon readout 242
 numerical indicator tube readout 246

INDEX

- Transistors 21
 - in blocking oscillator circuit 270
 - junction 232
 - PNP 235
 - point contact 232
- Transmission detectors 335
- Transwitch 259
- Trigger current 44
- Trigger electrodes 49, 302, 305
- Trigger gap 305
- Trigger potential 45
- Trigger striking potential 45
- Trigger tetrodes 46
- Trigger to trigger coupling 57
- Trigger tube circuit for the operation of a magnetic counter from a Dekatron 116
- Trigger tube counting 67
 - circuits 46
- Trigger tube coupling 130
- Trigger tube coupling circuits, for double pulse tubes 82
 - power supply for, for double pulse tubes 85
- Trigger tube resistance-capacitance timer circuit 373
- Trigger tube ring circuits, design of 61
- Trigger tube ring counters 49
- Trigger tube welding timers 373
- Trigger tubes 44, 53, 56, 103, 277
 - binary circuits 46
 - characteristics of 45, 46
 - discharge in 45
 - ionisation time 46
 - table of 64
- Trigger voltage 45, 303
- Triggering of valve binary stages 218
- Triggering discharge 303
- Triggering transistors 234
- Trigistor 259, 262
- Trinistor 259
- Triodes, cascode 333
- Trochoid 182
- Trochoidal path 182
- Trochotron 69, 181, 183-202
 - basic circuit 183
 - circuits 189
 - construction 183
 - coupling to Dekatrons 195
 - drive circuits 189
 - extinguishing voltage 185
 - flat plate switching grids 193
 - leakage currents 187
 - load line 185
 - low voltage 193
 - magnetically shielded 188
 - maximum speed 188
 - mounting 189
 - operation of 183
 - output pulse 198
 - practical precautions 188
 - presetting 195
 - principle of operation 183
 - readout 191
 - reset 188, 191, 195
 - resolving time 188
 - rod shaped switching grids 200
 - scaling factors 199
- Trochotron *continued*
 - set zero switch 188
 - shape of electrodes 183
 - spade characteristics 184
 - spade load resistor 185
 - spade supply voltage 185
 - switching grids 186
 - table of data 212
 - target characteristics 187
 - unshielded 189
- Tunnel diode, 20 Mc/s decade scaler 269
 - bistable circuits 265
 - chain circuits 267
 - characteristic 265
 - counting circuits 264
 - decade circuit 267
 - decimal coded binary system 269
 - ring circuits 269
- Tunnelling effect in semiconductors 265
- 2π counting 315
- Unsmoothed power supplies 56, 302
- Valve, ring. *See* Ring valve
- Valve binary circuits 216
- Valve counting circuits 12
- Valve decade using gating diodes 220
- Valve equivalents 375
- Valve ring counting circuits 227
- Valve scalars 21
 - circuits 216-31
 - reset 221
- Valve ternary circuit 230
- Virtual earth 281
- Visual display. *See* Display
- Visual readout. *See* Readout
- Voltage comparators 365, 366
- Voltage dependent resistor 34, 65, 116
- Voltage measuring circuit 277
- Voltage stabiliser tubes 150
- Voltage stabilisers 41
- Voltage to frequency conversion 367-68
- Voltage to time conversion 365
- Voltmeters, digital 362-68
 - integrator or voltage to frequency conversion technique 366
 - potentiometric or successive approximation technique 363
 - ramp technique 365
- VOR Navigational aids 362
- Welding, timers for 369-73
- Weston S462 digital indicator 308
- Whiddington circuit 350
- Zener diodes 364
- Zero offsetting techniques 367
- Zero second guide 93
- Zero state of binary counter 216
- Zero state of transistor binary 232

Index to Component and Equipment Codes

1C21 65
 1N2939A 266
 1TD 37
 1TD, t9r0 39
 1014 320
 1021C 279
 12AT7 82
 12AU7 195
 2D21 66
 2N1968 264
 3C30 262
 4D20-10 262
 4D40-10 260
 5695 203
 5823 64, 65
 5823A 65
 6476 69, 119
 6476A 119
 6700 212
 6701 212
 6704 212
 6710 213
 6802 119
 6879 119
 6909 119
 6910 118, 119
 7155 119
 7586 204
 7978 119
 8262 119
 90C1 179
 B5018 297
 B5094 297
 B50113 297
 B6037 297
 BD-203 212
 BD309 188
 BD311 212
 BIP-8001 250
 BIP-8002 251
 BX1000 213
 BX3000 213

CCT6 64
 CV2223 133
 CV455 82
 CV5277 212
 CV5290 212
 CV6103 212

DZ10 120

E1T 12, 20, 21, 69, 154, 295
 E299DE/P232 34
 E299DE/P338 34
 E299DE/P342 34
 E88CC 82
 E90CC 167, 178, 170
 E92CC 167

ECC81 82
 ECC91 170
 ECT100 70, 146, 151
 EL821 195
 EM84 351
 EN91 66
 ER1 52, 64
 ER2 64
 ER3 52, 64
 ER32 64
 ER33 64
 ET51 186, 201, 212
 EZ10A 134
 EZ10B 68, 70, 134, 144

F9007 297
 F9008 297
 F9009 297

G1/237G 49, 65
 G1/238G 49, 65
 G1/371K 59, 60, 65, 345
 G10/241E 68, 124, 133, 352
 G150/2D 65
 G240/2D 65, 345
 GC10/2P 113
 GC10/4B 69, 93, 99, 113, 114, 361
 GC10/4B/L 93, 114
 GC10B 69, 93, 113, 114
 GC10B/L 93, 113, 114
 GC10B/S 93, 113, 114
 GC10D 69, 70, 108, 111, 113, 114, 198
 GC12/4B 93, 99, 113, 114, 361
 GCA10G 69, 101, 104, 105, 107, 113, 114, 346
 GD150M 56, 117
 GDT120M 64
 GDT120T 64
 GK10 64
 GK32 64
 GK33 64
 GK40 64
 GK42 64
 GN4 298
 GN5 298
 GN5A 298
 GN6 298
 GP10/2P 114
 GPE120T 64
 GPE175M 51, 52, 64
 GR2G 297, 301
 GR2H 297, 301
 GR4G 297
 GR10A 191, 221, 299
 GK10G 56, 104, 192, 246, 300, 301
 GR10H 192, 246, 302
 GR12G 297
 GR12H 297
 GR15 64, 65
 GR16 64
 GR20 57, 64, 372

INDEX

GR21 61, 64, 65
GR31 64
GR32 64
GR33 64
GR41 64
GR43 64
GS10C/S 69, 71, 93, 113, 114
GS10D 98, 113, 114
GS10E 98, 113, 114
GS10G 101, 113, 114
GS10H 93, 101, 113, 114
GS10J 101, 113, 114
GS10K 113, 114
GS12C 113, 114
GS12D 93, 108, 113, 114
GSA10G 69, 101, 104, 105, 107, 113, 114, 346
GTE120Y 64, 103
GTE130T 64
GTE175M 51, 52, 56, 64, 94
GTR120W 56, 64
GTR150W 116
GTR80M 64

M0-10R 188, 201, 212

N530F 221, 359
N600 288
N645A 292

OA4G 65
ORP60 57

P22 307
P32 307
P40 307

QT1250 64
QT1251 64

RS240AF 345

S462 308
SR2 62

VS10G 183, 191, 192, 212
VS10H 191, 192, 212
VS10K 193, 212

XA653 269
XC13 65
XC18 46, 47, 52, 56, 65
XC22 65
XC23 47, 65
XC24 52, 56, 65

Z302C 91, 92
Z303C 92
Z502S 92
Z503M 221, 299
Z504S 69, 87, 90, 92
Z505S 90, 92
Z510M 57
Z520M 53, 55, 56, 91
Z521M 297
Z550M 247, 297, 302, 305
Z70U 49, 372
Z70U/Z700U 65
Z70W 49
Z70W/Z700W 65
Z71U/Z701U 65
Z700U 49, 53, 55, 82, 83, 85, 86
Z700W 49, 52, 56
Z701U 42, 50
Z803U 65
Z804U 45
Z806W 65, 85
Z900T 65
ZC1010 65
ZM1021 297
ZM1022 298