

P. MAUSER.
RECOIL OPERATED FIREARM.

No. 584,479.

Patented June 15, 1897.

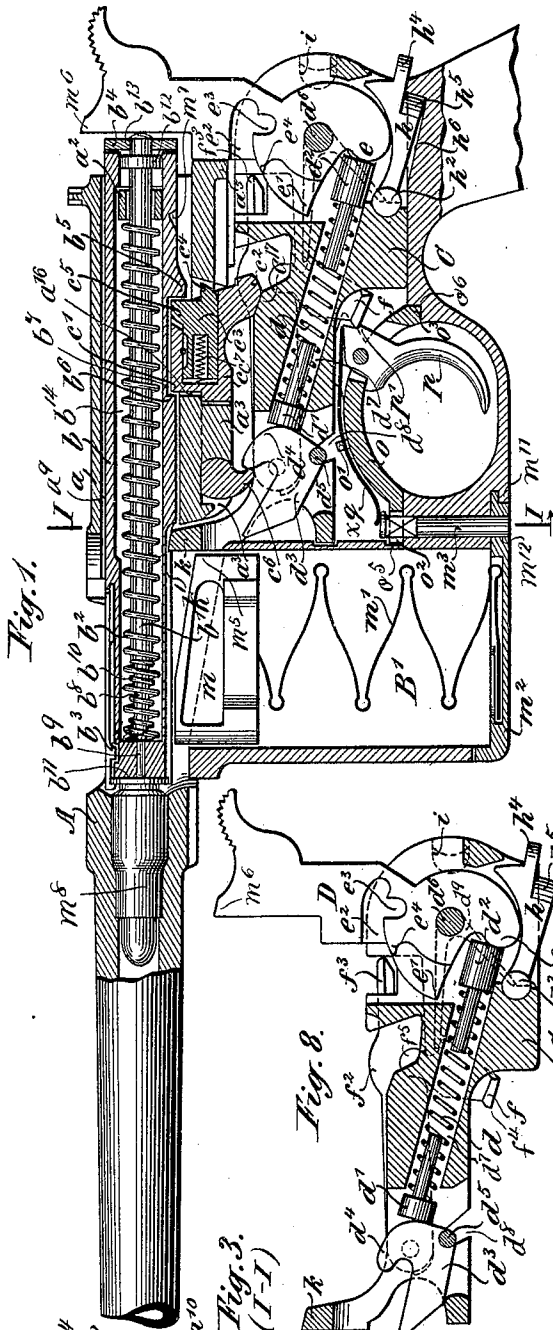

Fig. 1.

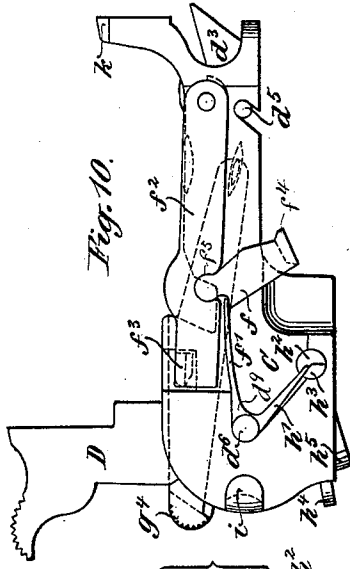

Fig. 10.

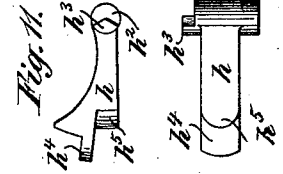

Fig. 11.

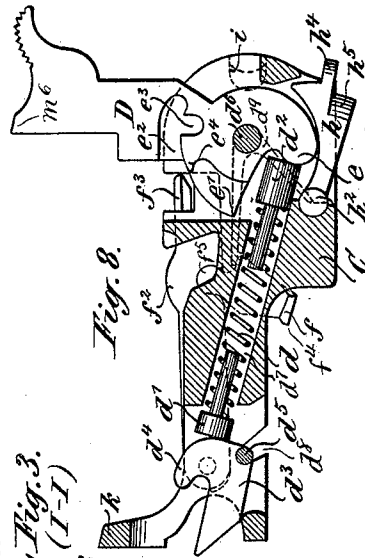

Fig. 8.

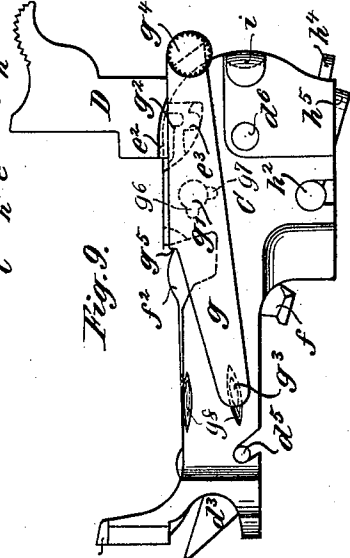

Fig. 9.

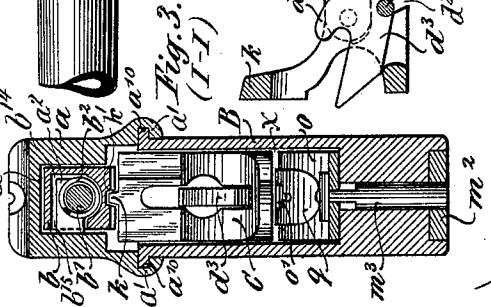

Fig. 3.
(I-I)

WITNESSES:
Fred White

Thos. J. Wallace

INVENTOR:
Paul Mauser,
By his Attorneys:

Arthur C. Jones & Co.

P. MAUSER.
RECOIL OPERATED FIREARM.

No. 584,479.

Patented June 15, 1897.

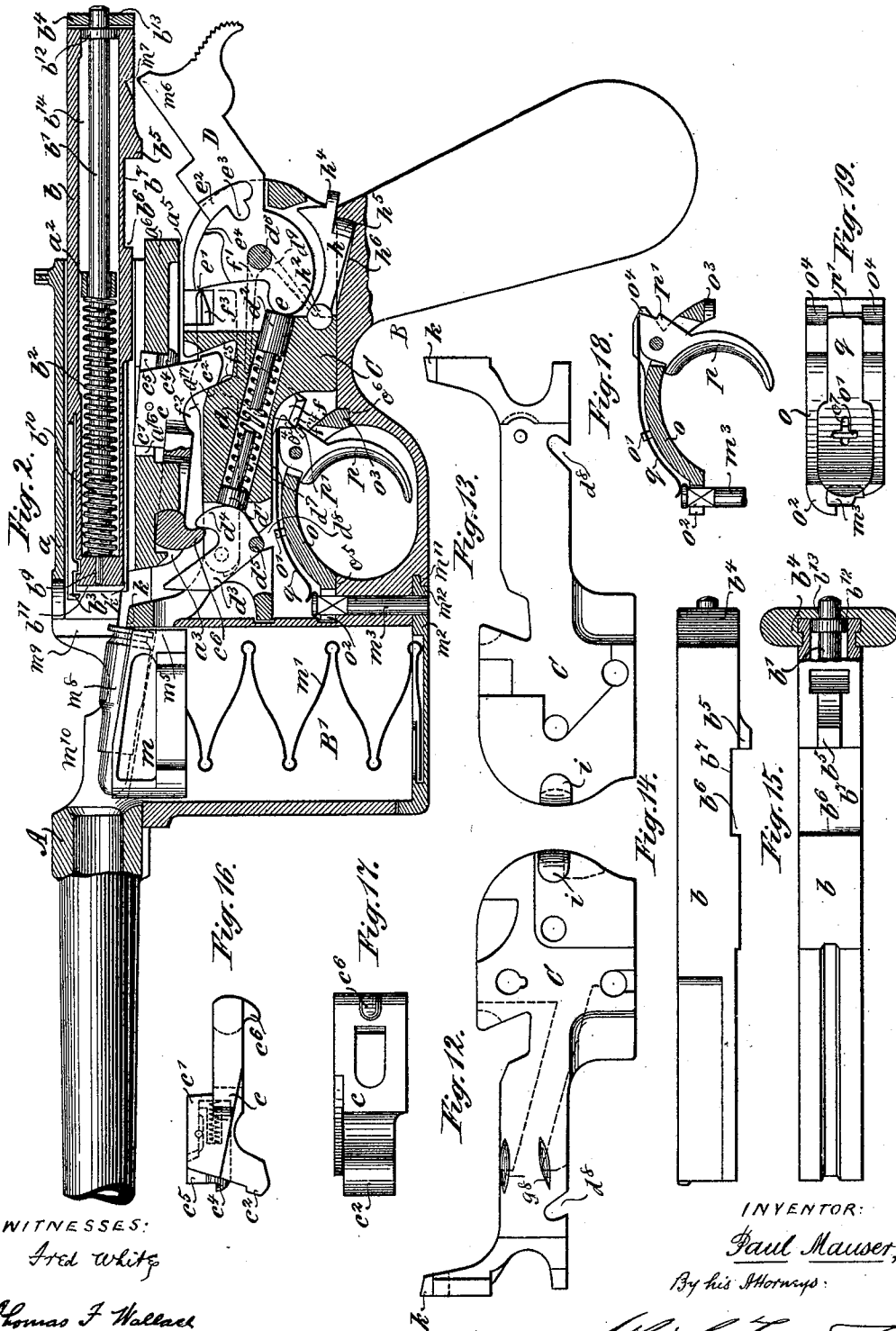

WITNESSES:
Fred White
Thomas F. Wallace

INVENTOR:
Paul Mauser,
By his Attorneys:
Wm. C. Fraser & Co.

UNITED STATES PATENT OFFICE.

PAUL MAUSER, OF OBERNDORF, GERMANY.

RECOIL-OPERATED FIREARM.

SPECIFICATION forming part of Letters Patent No. 584,479, dated June 15, 1897.

Application filed February 14, 1896. Serial No. 579,263. (No model.) Patented in Germany December 11, 1895, No. 90,430; in Switzerland January 9, 1896, No. 11,943; in Belgium January 9, 1896, No. 119,462; in France January 10, 1896, No. 253,098; in England January 14, 1896, No. 959; in Norway January 22, 1896, No. 4,780; in Hungary February 29, 1896, No. 5,675; in Austria March 11, 1896, No. 46/903; in Italy March 31, 1896, No. 40,594/362; in Spain May 9, 1896, No. 18,582; in Brazil July 28, 1896, No. 2,088, and in Denmark January 19, 1897, No. 925.

To all whom it may concern:

Be it known that I, PAUL MAUSER, manufacturer of guns, a subject of the King of Württemberg, residing in Oberndorf-on-the Neckar, in the Kingdom of Württemberg and Empire of Germany, have invented certain new and useful Improvements in Repeating Magazine-Firearms, of which the following is a specification.

This invention is the subject-matter of Letters Patent in Germany, No. 90,430, dated December 11, 1895; in Great Britain, No. 959, dated January 14, 1896; in Switzerland, No. 11,943, dated January 9, 1896; in Belgium, No. 119,462, dated January 9, 1896; in France, No. 253,098, dated January 10, 1896; in Spain, No. 18,582, dated May 9, 1896; in Norway, No. 4,780, dated January 22, 1896; in Italy, No. 40,594/362, dated March 31, 1896; in Brazil, No. 2,088, dated July 28, 1896; in Austria, No. 46/903, dated March 11, 1896; in Hungary, No. 5,675, dated February 29, 1896, and in Denmark, No. 925, dated January 19, 1897.

This invention relates to firearms; and the main object of the invention is to provide an improved magazine repeating firearm with a movable barrel in which the recoil caused by the shot is used to unlock and open the breech to eject the empty cartridge-case and to cock the firing mechanism as well as to compress a number of springs arranged in such a manner as to effect the loading of a fresh cartridge, the relocking of the breech and locking of the bolt, and the advancing movement of the barrel. Upon these principles, which are already partly known, I have devised a magazine-firearm in which all previous experiences in respect to this class of arm have been carefully taken into consideration, not only with regard to its ballistic qualities, but especially by the peculiar skilful construction of the component parts and the manner of connecting them without the aid of screws, whereby the improved firearm is in every way well adapted for military purposes.

The invention will be described, and is illustrated in the accompanying drawings, as ap-

plied to a repeating pistol, but it will be understood that it may be applied to other kinds of arms—such, for example, as any automatic or semiautomatic hand-firearms.

In the drawings, Figure 1 is a fragmentary vertical longitudinal section through a locked and bolt-locked firearm, the parts being in the position occupied at the moment of firing. Fig. 2 is a similar view, but showing the breech opened and the hammer cocked. Fig. 3 is a cross-section drawn on the line 1 1 of Fig. 1 and looking rearwardly. Fig. 4 is a side view of the barrel withdrawn from the lock-case and showing a longitudinal vertical section of the receiver and the locked breech-bolt. Fig. 5 is an under side view of the barrel. Fig. 6 is a fragmentary longitudinal vertical section through the lock-case and the cartridge-magazine. Fig. 7 is a plan of the same. Fig. 8 is a longitudinal vertical section through the lock. Figs. 9 and 10 are opposite side views of the same; and Figs. 11 to 19, inclusive, are views showing details.

The essential parts of the improved firearm are the following: first, the barrel A, the rear end of which serves as a receiver *a* to the breech-bolt and the bolt-locking block; second, the lock-case B, which serves at the same time as a cartridge-magazine B', and is provided at its upper edges with ribs *a*¹⁰ to guide the movable barrel; third, the part C, which contains the firing and securing mechanism and is coupled to the barrel through means of the locking-block *c*, so as to bring the latter under the influence of the mainspring and thereby cause by the rearward movement of the barrel the unlocking of the breech-bolt.

As previously stated, the function of the improved firearm is based upon the known principle of using the recoil to move the barrel. The mechanical action performed by the rearward-moving barrel is only a preliminary one and serves to unlock the breech-bolt and to cock the gun, but at the same time by the great velocity of the rearward movement of the barrel, and in spite of the relatively small distance traveled by the same, such a momentum is given to the breech-bolt as to enable the latter to overcome the resistance of

its restoring-spring and to fully open the breech and eject the empty cartridge-case. The loading of a fresh cartridge, the locking and bolt-locking of the breech, the forward movement of the barrel, and finally the firing are effected, as above stated, partly by the restoring-spring and partly by the mainspring, which springs were both compressed by the recoiling parts of the firearm at the moment of firing.

The preferred forms and arrangements of the improvements incident to the present invention and their operations with respect to the purposes set forth will now be explained in detail, as follows:

The barrel A is formed with or has at its rear part (see Figs. 4 and 5) the receiver *a*, in which a sliding bolt *b* of suitable cross-section is placed. The receiver is provided with means to receive the locking-block *c*, serving to lock the breech-bolt, and with guides or grooves *a'* for the coupling of the barrel to the lock-case B and to enable the barrel to slide thereon.

The bolt *b* is shown in square cross-section and has a central bore (see Figs. 1, 2, 3, and 4) to receive the firing-pin *b'* and the restoring-spring *b²*. The forward part of the bolt is provided with a cartridge-shell extractor *b³* at the rear under part, with a notch or recess *b⁷* for the locking-block *c*, and flanked in front by a nose *b⁶* and in rear by a nose *b⁵*, serving to receive the locking-block *c* to lock the breech-bolt.

As shown at Figs. 1, 2, 3, and 4, a hollow projection or pin *a²*, fixed to the receiver, projects into the hollow interior *b¹⁴* of the breech-bolt through an opening *b¹⁵* in the side thereof and serves as an abutment for one end of the restoring-spring *b²*, the other end of which presses against the front end of the interior of the breech-bolt, thus holding the latter in a closed position by its pressure. The firing-pin *b'* has at its front end two reductions in diameter *b⁸* and *b⁹*, and has a small spiral spring *b¹⁰*, surrounding its portion *b⁸*, by which it is held back behind the closing face or plate *b¹¹* of the breech-bolt *b*, so that it shall not touch the cap of the cartridge except when it is pushed forward by means of the hammer D. The rear end of the firing-pin is provided with a collar *b¹²*, which abuts against a cap or closing-bar *b⁴*, having a milled handle carried on, coupled to, or slid over the rear end of the breech-bolt, thus closing the latter at its rear end. This cap or closing-bar is held in its position by the rear end of the firing-pin projecting into or through its recess *b¹³* and out of the breech-bolt, when its end can be struck by the hammer D.

The locking-block *c*, which serves to lock the breech-bolt closed, is movably and removably connected to the under side of the receiver *a*, so as to turn freely round one of its ends, by means of a small flattened cross-bar slid between or engaged by claw-shaped projections *a³* *a³* on the case *a*. The other end

of the bolt-locking block *c* forms or has at its upper side a locking-nipple *c'*, which projects through a suitable hole *a¹⁶* in the bottom of the breech-case *a* and enters the recess *b⁶* in the breech-bolt *b*, and thereby secures the latter closed, while the lower rear end of the locking-block *c* is provided with a tailpiece *c²*, which at the forward movement of the barrel comes into contact with an inclined surface *a¹⁷* of the part *c*, which causes it to move upward, and thus causes the nipple *c'* to enter the recess *b⁶* before the barrel A can be pushed forward into the firing position. Upon this condition the proper functions of the arm depend, as it is impossible, on the one hand, to fire the arm unless the barrel has been fully returned to its initial or firing position, and as, on the other hand, if the barrel had stopped behind after the firing it could not make the before-mentioned backward movement, which is necessary to put the arm in a condition ready for firing.

As the closing of the breech and the forward movement of the barrel are caused, respectively, by the action of two separately-operating springs—viz., the restoring-spring *b²* and the mainspring *d*—it will be necessary to make the functions of the latter spring depend on the former spring in such manner that the breech must be closed before the barrel can be pushed forward. For this purpose a catch *c³* is provided at, in, or on the rear end of the locking-block *c*, between the locking-nipple *c'* and the tailpiece *c²*, which catch, projecting rearward, is constantly under the pressure of a small spiral spring *c⁷* and kept with its nose *c⁴* against the under side of the receiver *a*, thus preventing the upward movement of the locking-block until the breech-bolt *b*, at its advancing movement, caused by the restoring-spring *b²*, abuts its cocking-nose *b⁵* against the projection *c⁵* of the catch *c³*, whereby the latter is pressed back into the locking-block *c*, so as to release the nose *c⁴* from the receiver, whereupon the upward movement of the locking-block, as well as the advancing movement of the barrel, can be effected in proper order.

Having thus far explained the peculiar features of the improved firearm with respect to the functions of the movable barrel and to the opening and closing and locking of the breech-bolt, I will now proceed to describe the manner in which the mainspring *d* causes the advancing movement of the barrel, as well as the special arrangements of the lock in connection both with the whole mechanism and with the mode of fixing the same within the lock-case.

As shown by Figs. 8, 9, and 10, the lock of the improved firearm consists of a main body C, carrying, with the exception of the trigger, all the parts necessary for firing, for coupling the lock to the barrel—that is to say, the locking-block *c*—and for fixing the lock within the lock-case B. The lock-body C is provided with a longitudinal oblique bore or socket *d⁷*,

within which the spiral mainspring d , acting on two press-bolts d' and d'' , is placed. The mainspring presses at one end against the tail portion e of the hammer D and at its other end against a hook d^4 of the coupling device d^3 , carried by bearing-pins d^5 , pivoted in suitable cuts or recesses d^6 in the side walls of the lock C. The coupling device d^3 serves, through the power of the mainspring d , to cause the advancing movement of the barrel and the uncoupling of the locking-block c by pressing its hook d^4 against a claw c^6 of the locking-block c , thus causing the latter either to turn downward, whereby the breech-bolt b is unlocked, or, when this cannot be done by reason of the relative positions of the respective parts, causing an advancing movement of the barrel to take place. It will be clearly understood that in consequence of the leverage of the mechanisms the force applied to cause the advancing movement of the barrel is by far greater than that causing the unlocking of the locking-block.

In the rear portion of the lock C is pivoted the hammer D, the axis d^6 of which has at one end a forked leaf or double spring d^9 , (see Fig. 10,) the one arm, f' , of which acts upon the trigger mechanism f , the other, h' , serving to keep down the lock-holding device h . Besides being in operative connection with the main spring d the hammer D is also directly in operative connection with the trigger-bar f and the safety device g . The trigger-bar f , under the influence of the above-mentioned arm f' of the double spring, acts on a lever f^2 , so as to cause the sear-nose f^3 of the latter to set against the beak e' of the hammer, thus holding the latter cocked.

The safety device g is pivoted by means of a bayonet-joint, preferably consisting of a pin g' , having a key-shaped head g^6 , which enters a similarly-shaped eye or socket g^7 , provided in the left side of the lock C, and this device is held in both its extreme positions by means of a catch or nipple g^3 , which enters suitable recesses g^8 in the side of the lock. When in the inactive position, the safety-nose g^2 of the device rests and moves in a groove or recess e^2 in the hammer D, and when in the active position this nose enters the notches e^1 or e^3 , according as the hammer is to be secured in a cocked or uncocked position. When the safety device is active, its nose g^5 (see Fig. 9) enters a notch a^4 in the under side of the receiver, (see Fig. 5,) and thus prevents the opening of the breech by fixing of the barrel against rearward movement.

The setting of the safety device is effected by means of its handle or knob g^4 , projecting at the rear end of the lock.

There still remains to describe the last part of the lock—viz., the lock-holder h , which is pivoted by means of a pin h^2 at the under side of the lock-body and is actuated by the arm h' of the double spring d^9 and serves to hold or couple the lock C, and with it the barrel,

within or to the lock-case B when the arm is completely mounted, as will be clearly understood from an inspection of the drawings. For this purpose the spring h' acts upon the inclined part h^3 of the pivot-pin h^2 , so as to force down the rear end of the lock-holder h , whereby the latter, when the lock is in position in the lock-case, abuts with its nose h^3 in the recess h^6 of the rear wall of the lock-case and prevents the lock and the barrel from accidentally sliding out of the lock-case. The lock-holder h is normally held in its holding position by the tail portion e of the hammer D. (See Fig. 1.)

In order to dismount the firearm—that is to say, to take off the barrel and to remove the lock from the lock-case—the hammer requires to be full-cocked and the lock-holder turned up by means of its handle or lip h^4 , projecting through the rear of the lock far enough to enable the nose h^3 to leave the recess h^6 at the rear part of the lock-case, after which the barrel and the lock can be pulled out of the lock-case. Without having previously cocked the hammer it is impossible to release the nose h^3 from the recess h^6 , because the hammer prevents its rising sufficiently, and thus the barrel is secured against becoming separated from the lock-case through the firing of the arm. The rear end of the lock-body is provided at both sides with claw-shaped projections i , which by entering the recesses n in the case B and by clipping the sides of the lock-case serve to prevent the lock from moving up or down when in position within the lock-case and at the same time serve to hold together the walls of the lock-case. The front portion of the lock extends far enough upward to serve as an ejector for the empty cartridge-cases, having a nose or piece k , which partly projects into the path or way of the breech-bolt, entering a groove k' therein and serves as an ejector, so that the empty cartridge case or shell on the opening of the breech strikes against the piece k and is thereby ejected.

The arrangements of the lock-case for holding the barrel, the lock, and the firing mechanism, as well as the arrangement of the magazine, are very simple. The front part of the lock-case B forms the magazine B', the arrangements of which are similar to those described in the specification of British Patent No. 15,390 of 1893. The cartridges m^8 are stored on a plate m in the interior of the magazine, which plate, being raised by a spring m' , brings the cartridges within the path or way of the breech-bolt b . The magazine-bottom is closed by a plate m^2 , which is held in its position by means of a spring-actuated bolt m^3 and cannot be removed till the bolt m^3 is pressed far enough up to permit the plate m^2 to be slid under it. The plate m is provided at its rear end with a rib m^5 , which when the magazine is emptied comes against the front end b^{11} of the recoiled breech-bolt, thus preventing the advancing

movement of the latter. By this means the user's attention is called to the fact that the magazine is empty and to the necessity of refilling it, which refilling is effected in any well-known manner, as by means of cartridge-holders. These holders containing a suitable number of cartridges may be introduced into corresponding grooves m^9 in the side walls of the opening m^{10} in the receiver at the front end of the same in such a manner that the cartridges from the holder are caused to drop into the magazine, after which the holder is withdrawn from the receiver, when the breech-bolt by being moved forward pushes a cartridge into the barrel, whereupon the firearm is again ready for firing.

If a partially-emptied magazine is to be filled up, this may be done either by withdrawing the breech-bolt b by hand and supplying a cartridge-holder, as before stated, or, if it is desired to fill in only a few single cartridges, by withdrawing the breech-bolt and fixing the same by slightly uncocking the hammer, the point m^8 of which, abutting against a corresponding face m^7 of the breech-bolt, will hold the latter back until the hammer is recocked after the magazine is refilled. If after this the hammer is recocked, the breech-bolt is moved forward by its spring b^2 and pushes with it the uppermost cartridge into the barrel in the manner before described.

Figs. 1 to 7 of the drawings show the arrangements adopted for the lock-case for receiving and guiding the barrel and for receiving and holding the lock in position. The ribs a' at the upper edge of the lock-case serve to guide the barrel and the groove h^6 , and cuts n at the rear end of the lock-case serve to hold or retain the whole of the upper mechanism within the same. The lock rests with its upper part against the barrel, or, rather, against the receiver, and with its lower part against the trigger-guard o , thus fixing the latter in position. The trigger-guard piece o is secured in its proper position within the lock-case by means of projections or pins o^2 o^3 , entering suitable recesses o^5 o^6 in the lock-case, and consists of a strong curved plate carrying the trigger p and the trigger-spring q . The latter is double ended and is made to act on both the trigger and the bolt or pin m^3 , which locks the magazine-bottom plate m^2 in position. The plate m^2 slides into a socket m^{11} in the case B and has a recess m^{12} , receiving the pin m^3 . As shown at Figs. 18 and 19, the trigger-spring is fixed to the upper side of the trigger-guard piece by means of a hook o' by passing the latter through the hole o^7 in the spring and turning the spring through a distance of ninety degrees.

The functions of the trigger are well known, but the peculiar construction of the improved firearm requires that the trigger-bar f , and with it the lever f^2 and its nose f^3 , shall ordinarily return immediately after firing to

their initial positions and catch the newly-cocked hammer without waiting for the release of the trigger p . For this purpose the trigger is pivoted to the trigger-guard piece o , so that its nose p' shall act upon the nose f^4 of the trigger-bar f only to the extent required for the release of the hammer. Then by moving it farther it becomes disengaged from the trigger-bar f by pushing the nose f^4 of the latter upwardly against the projection o^4 on the piece o . The nose f^4 is forced back as the bar f swings on its movable coupling f^5 with the lever f^2 until the nose f^4 is moved off the trigger-nose p' , whereupon the bar f and lever f^2 are free and the trigger-bar f is caused by the spring f' to return to its initial position and to catch and hold the newly-cocked hammer.

In order that at the releasing of the trigger the nose p' may be replaced beneath the nose f^4 of the trigger-bar in readiness for the next shot, said bar f is pivoted by the coupling f^5 to the lever f^2 , so as to give way to or snap over the rearwardly-moving trigger-nose p' and enable the latter to pass under it, whereupon the influence of the spring f' returns it against the top of the nose p' .

As already indicated, the dismounting and remounting of the parts of the firearm is very simple, owing to the improved construction and the absence of any screw. All parts are fixed to their holding-pieces by means of bayonet-joints consisting, preferably, of pins having key-shaped heads entering corresponding eyes, or by snaps, catches, or interlocking portions, or rest against each other in such a manner as to permit of the dismounting and remounting of the firearm without the aid of tools.

In operation the manipulation of the firearm shown is also very simple and is limited to the following operations: first, cocking of the hammer by withdrawing the breech-bolt; second, filling of the magazine, as by insertion of a cartridge-holder, pushing down the cartridges from the holder until the magazine is full, and then withdrawing the cartridge-holder; third, shooting by pulling the trigger till the store of cartridges is exhausted. After these manipulations only three operations are required for getting the firearm again ready for firing—viz, again filling the magazine, as by the insertion of a cartridge-holder, pushing down the cartridges, and withdrawing the cartridge-holder.

In a few words certain advantages of the improved firearm may be stated to consist in, first, the small number of and compact arrangement of the parts composing the arm; second, the facility for dismounting and remounting the firearm without the aid of any tool; third, the absence of screws of any description; fourth, the applicability of the improvement to various kinds of firearms.

It will be seen that this invention provides improvements which can advantageously be availed of in whole or in part for various con-

structions of firearms and which can be obtained by various structural arrangements of the several parts going to make up the arm. The bolt shown is a reciprocating bolt having no oscillatory movement, and the bolt-lock may be any suitable catch movable laterally toward or from the bolt to lock or release it, the bolt or its lock being reciprocally constructed to interengage and effect the locking of the bolt against longitudinal movement when desired. The bolt-lock *c* shown is separably coupled to the receiver *a*, so that it oscillates thereon on an axis near its forward end and participates in the movements of this receiver. The receiver *a* has a substantially square or rectangular receiving-chamber *a*⁹, receiving and fitting the bolt, and a bottom wall *a*¹¹, on which the lugs *a*³ are formed and through which the aperture *a*⁶ leads to the chamber *a*⁹ for permitting entrance of the bolt-lock *c* to the bolt. The tail *c*² of the bolt-lock *c* engages any suitable fixed or movable parts, as shown, for automatically operating the bolt-lock *c* at proper times.

The lock *C* comprises a rigid frame or block the bottom and side walls of which fit the chamber *r* of the case *B*, which block carries the hammer, mainspring, and trigger and safety mechanism, and serves also to couple all parts of the arm together when it itself is coupled in position in the lock-case. It provides a convenient portion for the placing of the faces desirable to the operation of the bolt-lock *c* and for the bearings for the various movable or separable portions of the mechanism, so that the external walls of the lock-case *B* may be imperforate side and bottom walls inclosing the breech mechanism.

It will be understood that my improvements can be availed of according to such modifications as circumstances or the judgment of those skilled in the art may dictate without departing from the spirit of the invention, and that the invention is not limited to the particular details of construction, arrangement, or combination of the parts nor to the particular use hereinbefore set forth as constituting the preferred form of my invention.

It will be seen that an important feature of my invention is that there are two distinct periods in the recoil movement of the parts. During the first period the barrel and receiver and the breech-bolt remain immovably coupled together, and all move back through a predetermined distance. In the construction shown this distance approximately equals the thickness of the front wall of the magazine. It is during this first period of movement that the rear nose *a*⁵ of the receiver acts against the hammer to cock it. Its action is so forcible that the momentum given to the hammer throws it to the fully-cocked position, even though the receiver is itself arrested shortly after acting against the hammer. During the second period the breech-bolt and the parts it carries alone move rearwardly, this move-

ment being caused solely by the momentum acquired by the breech-bolt during its recoil movement with the receiver, which momentum is sufficient to carry it back at least to the fully-open position, at which it may be stopped in any suitable manner—as, for example, in the manner shown, wherein it is gradually arrested by the compression of its restoring-spring *b*³. The independent rearward movement of the bolt in the construction shown is slightly in excess of the length of the magazine.

The first period ceases when the bolt-lock *c* is disengaged from the breech-bolt, by which time the hammer has been cocked and is out of the path of the bolt. The second period of recoil movement ceases when the momentum of the breech-bolt is overcome.

It must be noted that in the construction shown the breech-bolt itself does not touch the hammer at all during the recoil, the hammer being cocked merely by the momentum imparted to it by the projection *a*⁵ of the receiver. This will be evident on consideration of the fact that the point where this projection strikes the hammer lies nearer to the pivot of the latter than does any part of the breech-bolt. Therefore from the beginning of the recoil the projection *a*⁵ in pushing the hammer rearwardly will remove the outer end of the same from the end of the breech-bolt more rapidly than the latter moves rearwardly, as the breech-bolt has the same speed of rearward movement as has the receiver.

At the beginning of the second period of recoil—that is to say, when the breech-bolt is freed—the bolt has only the same velocity as the receiver, and hence only the same velocity as that part of the hammer against which the receiver acted, as both of these parts derive their movement from the receiver and are flung back merely by the momentum imparted to them thereby. Hence it follows that the hammer which at the end of the first period of recoil was at a distance from the receiver and which was then moving at a speed equal at least to the speed of movement of the latter cannot come in contact with the breech-bolt during the subsequent rearward movement thereof.

In practice it will be readily seen that the hammer is thrown to the fully-cocked position by the short impulse imparted to it by the receiver, which I have demonstrated by clamping the bolt and receiver so together that the bolt could not participate in the second movement, but was stopped with the receiver at the end of the first. In such case the hammer flies back and is cocked exactly as though the bolt had its independent movement. Practical use also demonstrates that the momentum relied on to move the several parts is abundant to effect the operations required of it.

Another important feature of improvement in a recoil-operated arm is the provision for holding the recoiled parts in their rearward

position upon emptying of the magazine, so that the stored power for returning them and reloading the arm will not be lost in a useless closing of the breech when no cartridge is in the barrel. Any suitable means for effecting this may be employed, but I prefer the construction hereinbefore described, wherein the feed-plate of the magazine, by rising in front of the bolt, prevents automatic return of the latter and of the receiver, thus holding the restoring-springs of both in their condensed positions and saving the power thus stored to automatically reload the arm and close the breech upon the refilling of the magazine or the depression of its feed-plate by pressing the cartridge thereon. In the automatic arm this plate not only saves the waste of the stored power, but it performs also the well-known function of warning the user of the emptiness of the arm by preventing forcible return of the bolt. Upon noting this warning the user will release the hammer by pressing the trigger and will manipulate the bolt by hand until the hammer engages the shoulder *m*⁷, and thereby holds the bolt retracted. Then a cartridge-package can be forced into the magazine, whereupon by fully cocking the hammer by hand it will release the bolt, and the latter can then automatically move forward, carrying the cartridge into the barrel and closing the breech, as well as releasing the bolt-lock *c*, which will then permit the barrel and receiver to automatically move forward, thus placing the arm in position again for automatic operation.

It will also be noted that the barrel is completely loaded and the breech fully closed before the barrel starts forward from its rearward position.

What I claim is, in firearms, the following-defined novel features and combinations, substantially as and for the purpose hereinbefore set forth, namely:

1. In recoil-operated firearms, a movable barrel and movable breech-bolt operated by the recoil, in combination with a bolt-lock locking said parts together in the locked position and freeing them during recoil, pivotally connected at its forward part to the barrel having a locking projection and free at its rear end, and then swinging toward and from the breech-bolt.

2. In recoil-operated firearms, a movable barrel and a movable breech-bolt carried thereby, in combination with a bolt-lock for said breech-bolt, locking the latter to the barrel during their movement together and freeing the bolt at a predetermined time, and a catch automatically holding said bolt-lock in its inactive position and actuated by the return of the breech-bolt to release the bolt-lock and permit the latter to relock the breech-bolt.

3. In recoil-operated firearms, a movable barrel and movable breech-bolt operated by the recoil, in combination with a bolt-lock pivoted to the barrel, movable therewith, and

locking the breech-bolt thereto during part of the recoil movement, and a spring tending to restore the barrel to its forward position, acting on the latter through said bolt-lock, compressed by the rearward movement of the barrel and releasing said bolt-lock.

4. In recoil-operated firearms, a movable barrel and a movable breech-bolt connected thereto and movable therewith and relatively thereto, in combination with a bolt-lock for said breech-bolt pivotally connected to said barrel and moving therewith, a spring compressed by the rearward movement of said barrel and tending to restore it to its forward position, and a coupler between said spring and barrel, swinging relatively to the latter and acting against said bolt-lock, said coupler receiving the rearward movement of the barrel and transmitting it to the spring, and receiving the tension of the spring and transmitting it to the barrel for restoring the latter.

5. In recoil-operated firearms, a movable barrel, a movable breech-bolt, and a hammer, in combination with a spring receiving the rearward movement of the barrel and reacting against the latter to restore it and against the hammer, said barrel in its rearward movement moving the hammer toward the cocked position, and compressing said spring, and trigger mechanism catching said hammer in the cocked position.

6. In recoil-operated firearms a movable barrel and a movable hollow breech-bolt connected thereto and moved rearwardly by the recoil, in combination with means for locking said breech-bolt, and a spring returning the latter to its locked position and located within the hollow interior of said breech-bolt, and a connection between said spring and barrel extending through the wall of the breech-bolt.

7. In recoil-operated firearms, a barrel, a receiver connected thereto, and a breech-bolt sliding in said receiver, in combination with a spring within the breech-bolt tending to move it to the closed position, a projection within the breech-bolt against which said spring reacts, fixed to the wall of the receiver and extending through the wall of the breech-bolt, and a firing-pin within the breech-bolt extending through the spring therein, means for holding said pin retracted, and a hammer for operating said pin.

8. In automatic firearms, a movable barrel and a receiver moving therewith, and a movable breech-bolt, all moved by the recoil, in combination with a restoring-spring condensed by the recoil of said barrel, means locking said barrel in its recoiled position, a restoring-spring for said breech-bolt condensed by the recoil of the latter and restoring the bolt to its forward position for closing the breech while said barrel is locked in its rearward position, and means releasing said barrel and permitting its spring to restore it to the forward position when said breech-bolt has been restored.

9. In firearms, a barrel and receiver, in com-

5 combination with a movable breech-bolt in the latter having an open rear end, a firing-pin within said breech-bolt, a spring holding said pin in position, and a coupling between said pin and breech-bolt separably engaging the latter and when in position thereon engaged by said pin and thereby prevented from separation from said breech-bolt.

10 10. In firearms, a barrel and receiver, in combination with a breech-bolt in the latter having an open end, a coupling b^4 sliding transversely on the end of said breech-bolt, and a firing-pin within said breech-bolt and movable axially thereof into engagement with and
15 engaging said coupling and preventing transverse movement thereof.

20 11. In firearms, a barrel and receiver, in combination with a breech-bolt within the latter having an open rear end and transverse grooves therein, a firing-pin within said breech-bolt having a projecting rear end, a spring holding said firing-pin rearwardly, and a coupling b^4 passing over the grooved end of the breech-bolt and having a hole b^{13} opposite
25 the end of said firing-pin and traversed by the latter, whereby said firing-pin, breech-bolt and coupling are connected together and can be separated without the use of special tools.

30 12. In firearms, a barrel, a receiver, and a bolt-lock, in combination with a lock-case carrying said parts and open at rear, and a lock-block separably fitting the interior of said lock-case beneath said breech-bolt and
35 bolt-lock, a hammer and a hammer-spring carried by said block, a trigger carried by said lock-case, and means for locking said block within said lock-case.

40 13. In firearms, a barrel having a receiver, and a movable breech-bolt therein, in combination with a bolt-lock separably coupled to said receiver beneath said breech-bolt, a lock-case carrying said parts, and a lock-block fitting within said lock-case below said bolt-lock, holding the latter in position on said receiver, and separably coupled to said lock-case, a hammer carried by said block, and a trigger connected to said lock-case.

45 14. In firearms, a barrel and breech-bolt, in combination with a lock-case carrying said parts, a trigger connected to said lock-case, and a lock-block fitting within said lock-case, separably coupled thereto and having an ejector-nose in the path of a shell when carried
50 by said breech-bolt, a hammer, and a hammer-spring.

55 15. In firearms, a barrel, receiver and breech-bolt, in combination with a lock-case carrying said parts, a trigger connected to said lock-case, and a lock-block within said case between said trigger and breech-bolt and separably coupled therein, a hammer carried by said block, a connection carried by said block between said hammer and the trigger,
60 and a safety-catch carried by said block for locking the trigger.

16. In firearms, a barrel and lock-case, in

combination with a block fitting within the interior of said case and carrying the lock mechanism of the arm, and a spring-catch
70 coupling said block within said case.

17. In firearms, a barrel and breech mechanism, in combination with a hollow lock-case, a hammer, a lock-block fitting within said case and carrying part of the mechanism
75 of the arm, a catch between said lock-block and case separably coupling said parts together, and reciprocal provisions between said hammer and catch preventing operation of the catch at a predetermined position of
80 the hammer.

18. In firearms, a barrel and breech mechanism, in combination with a lock-case carrying said parts, lock mechanism within said lock-case, and a trigger for the arm beneath
85 said mechanism, a trigger-guard separably coupled within said lock-case and carrying said trigger, and a trigger-spring carried by said trigger-guard and removable therewith.

19. In recoil-operated firearms, a barrel and
90 a breech-bolt and bolt-lock movable with the recoil, in combination with a lock-case carrying said parts and connected thereto by separable connections, and a lock-block fitting within said lock-case, carrying part of the
95 lock mechanism, and when in position preventing separation of said barrel, breech-bolt and said case.

20. In a recoil-operated firearm, a barrel moved rearwardly by the recoil and having
100 an extension a^6 and a nose a^5 at rear striking the hammer and moving it to the cocked position, a breech-bolt b connected to and moving with and independently of the barrel, said barrel having a receiver a inclosing said
105 breech-bolt, in combination with a hammer in the path of said nose, and means causing said barrel and breech-bolt to move together, said barrel moving rearwardly until its nose has impelled said hammer toward the cocked
110 position and moved it away from said breech-bolt, means simultaneously unlocking the breech-bolt from the barrel and holding the barrel in a retracted position until the breech-bolt has ejected the empty cartridge in its
115 rearward movement, readvanced and fed another cartridge into the barrel, a spring restoring the breech-bolt to the locked position, means releasing the barrel from its rearward position, and means restoring it to the firing
120 position.

21. In recoil-operated arms, a breech-bolt and a barrel movable with the recoil, in combination with means locking the breech-bolt and barrel together during their initial rear-
125 ward movement, a spring condensed during this movement and tending to restore them to the firing position, means releasing the breech-bolt and permitting its further rearward movement, means then locking the barrel
130 against forward movement, a spring compressed by the further rearward movement of said breech-bolt and restoring it to its closed position relatively to said barrel, means then

locking the barrel and breech-bolt together, and means for restoring the barrel and breech-bolt to the firing position.

22. In firearms, a barrel and lock-case, in
5 combination with a trigger guard-piece *o* carried by said lock-case, a trigger *p* carried by said guard-piece, a magazine *B'*, a bottom plate *m*² therefor, a spring *q* for said trigger and for holding said plate, a trigger-lever *f*,
10 said trigger having a nose *p'*, said guard-piece having a shoulder *o*⁴, and said lever rubbing against said shoulder until free from said nose when the trigger is pulled, whereby upon the
15 release of the trigger-bar by its being rubbed off said nose it can immediately fall into position for recocking.

23. In firearms, a barrel and a lock-case, in combination with a trigger guard-piece *o* carried by said lock-case, a trigger *p* carried by
20 said guard-piece, a magazine *B'*, a removable bottom plate *m*² therefor, means preventing escape of said plate, and a spring *q* acting against said means and against said trigger.

24. In firearms, a barrel and lock-case, in
25 combination with a spring-actuated trigger *p*, having a nose *p'*, a trigger-lever *f* engaging said nose, and a fixed shoulder *o*⁴ engaging said lever as the latter is moved by the trigger, and freeing the lever from the trigger-nose
30 when the trigger is pulled, whereby upon the release of the trigger-lever by its being rubbed off said nose, it can immediately fall into position for recocking.

25. In firearms, the lock-case *B* having a
35 magazine *B'* in its forward part, in combination with a removable bottom plate *m*² fitting said case and held thereon by the trigger-

spring, the trigger, a trigger-spring moving the trigger and preventing escape of said plate *m*², a feeding-plate *m* within said maga- 40
zine and movable into the path of the breech-bolt, a barrel and a breech-bolt, the latter movable above said magazine, and lock mechanism for the arm, whereby when the maga- 45
zine is empty, the feeding-plate will stand in the path of the breech-bolt and indicate such emptiness.

26. In firearms, the combination with a lock-case *B*, of a barrel *A* movably connected thereto, a lock-block *C* connected to said case, 50
located within the latter by moving it therein from the rear, a holder *h* pivoted at the rear end of the block *C* and having a spring *h'* and a nose *h*⁵; said case having a recess *h*⁶ entered by said nose, a hammer *D* having a tailpiece 55
e holding said holder in engagement with said recess, and trigger mechanism for said hammer.

27. In firearms, the combination with a lock-block *C*, of a hammer *D* pivoted thereto 60
and having notches *e*³ *e*⁴, and a safety-lock *g* pivoted intermediate of its ends to said block, and having a nose *g*² at one side of its fulcrum movable into engagement with said notches, 65
and a catch *g*³ at the other side of its fulcrum for holding it in position.

In witness whereof I have hereunto signed my name in the presence of two subscribing witnesses.

PAUL MAUSER.

Witnesses:

W. HAUPT,
ALOYS GOBANZ.